



SCDF

The Life Saving Force

... for a safer Singapore



**CODE OF PRACTICE FOR
FIRE PRECAUTIONS IN
RAPID TRANSIT SYSTEMS 2022**

CONTENTS

Chapter 1 – Scope

Clause 1.1 Scope

Clause 1.2 Codes and Standards

Clause 1.3 Abbreviations

Clause 1.4 Definitions

Chapter 2 – Station Means of Escape

Clause 2.1 General

Clause 2.2 Determination of Exit Requirements

Clause 2.3 Station with two or more platforms stacked above one another

Clause 2.4 Station with platforms located side by side separated by trainway

Clause 2.5 Special requirements for person with disabilities (PWDs)

Annex 2A – Exiting Analysis

Chapter 3 – Station structural fire precautions

Clause 3.1 General

Clause 3.2 Provision of compartment walls and compartment floors

Clause 3.3 Fire resistance of elements of structure

Clause 3.4 Test of fire resistance

Clause 3.5 External wall

Clause 3.6 Separating walls

Clause 3.7 Compartment walls and compartment floors

Clause 3.8 Protected shafts

Clause 3.9 Protection of openings

Clause 3.10 Exit staircases

Clause 3.11 Concealed spaces

Clause 3.12 Fire stopping

Clause 3.13 Restriction of spread of flame over surfaces of walls and ceilings

Clause 3.14 Roofs

Clause 3.15 Materials for construction

Clause 3.16 Use of plastic material

Annex 3A – Notional Periods Of Fire Resistance

Annex 3B – Permitted Limits Of Unprotected Area

Chapter 4 – Site planning and external firefighting provision

Clause 4.1 General

Clause 4.2 Provision for external access to station for firefighting and accessibility of site to firefighting appliances

Clause 4.3 Access to stations with breeching inlets

Clause 4.4 Fire hydrant

Chapter 5 – Electrical Power Supplies

Clause 5.1 General

Clause 5.2 Primary and Secondary Power Supplies

Chapter 6 – Firefighting Systems

Clause 6.1 Portable Extinguishers

Clause 6.2 Dry Rising Main and Hose Reel Systems

Clause 6.3 Electrical Fire Alarm System

Clause 6.4 Fire Sprinkler Installation

Clause 6.5 Fixed Automatic Fire Extinguishing Systems

Clause 6.6 Lifts

Clause 6.7 Colour Scheme Of Fire Protection Systems

Clause 6.8 Redundancy For Fire Pumping System

Chapter 7 – Mechanical Ventilation & Smoke Control Systems

Clause 7.1 Air-Conditioning And Mechanical Ventilation Systems

Clause 7.2 Pressurisation For Exit Staircases

Clause 7.3 Smoke Control System

Clause 7.4 Redundancy For Mechanical Ventilation And Pressurisation Systems

Annex 7A – Tenable Environment

Chapter 8 – Emergency Lighting & Voice Communication Systems

Clause 8.1 Exit Lighting And Exit Sign

Clause 8.2 Emergency Voice Communication System

Clause 8.3 Hotline Telephone Between Stations And OCC

Clause 8.4 Signage For Firefighters

Clause 8.5 Plans For Firefighters

Clause 8.6 Fire Command Centre

Chapter 9 – Other Requirements

Clause 9.1 General

Clause 9.2 Integration And Interface For Stations

Clause 9.3 Underground or Enclosed Trainway

Clause 9.4 Aboveground Trainway

Clause 9.5 Depot

Clause 9.6 Operation Control Centre

Clause 9.7 Rapid Transit System Facility Buildings

Clause 9.8 Electrical Transformer Room In Underground Structures

Appendix 1 – Fire Safety Report

Clause 1.0 General

Clause 2.0 Contents of the report

Clause 3.0 Brief explanatory note for outline report on fire protection and life safety features

Appendix 2 – Fire Safety Instruction Manual

Clause 1.0 General

Clause 2.0 Scope

Clause 3.0 Contents Of The Manual

Clause 4.0 Relevant Information To Be Included In The Fire Safety Instruction Manual

CLAUSE 1.1 SCOPE

1.1.1 General

Rationale

This Code is applicable to all proposed Rapid Transit Systems (RTS) including addition and alteration works to the existing RTS.

- a. This Code aims to establish minimum requirements to provide an acceptable degree of safety from fire and its related hazards.
- b. Fire safety on a Rapid Transit System (RTS) shall be achieved through a composite of facility design, operating equipment and hardware, procedures, and software subsystems that are integrated to provide requirements for the protection of life and property from the effects of fire. The level of fire safety desired for the whole system shall be achieved by integrating the required levels for each subsystem.
- c. This Code covers fire protection and life safety requirements for underground, surface, and elevated RTS including trainways, transit stations and other requirements for train maintenance depot, on-line electric substation, Operations Control Centres (OCC), and RTS facility buildings.
- d. This Code shall not apply to the following:
 - (1) Conventional freight or passengers railroad systems including those that provide commuter services.
 - (2) Buses and trolley coaches.
 - (3) Any other system of transportation not included in the definition of RTS.

1.1.2 Train maintenance depot, on-line electric substation, OCC, and RTS facility buildings

Fire safety requirements for train maintenance depot, on-line electric substation, OCC, and RTS facility buildings shall be in accordance with the Code of Practice for Fire Precautions in Buildings, except where herein modified in this Code.

1.1.3 Energy Storage System (ESS)

Fire safety requirements for ESS shall be in accordance with the Code of Practice for Fire Precautions in Buildings, except where herein modified in this Code.

1.1.4 Solar Photo-Voltaic (PV) installation

Fire safety requirements for solar photo-voltaic (PV) installation shall be in accordance with the Code of Practice for Fire Precautions in Buildings, except where herein modified in this Code.

1.1.5 Fire Safety Report ([Appendix 1](#))

Fire Safety Report for station projects/ fire safety provisions specified by SCDF shall be submitted when making building plan submission.

1.1.6 Fire Safety Instruction Manual ([Appendix 2](#))

- a. Fire Safety Instruction Manual for station projects/ fire safety provisions specified by SCDF shall be submitted when making application for Temporary Fire Permit or Fire Safety Certificate
- b. The station owner shall keep and maintain the Fire Safety Instruction Manual at all times and present to the Qualified Person (QP) upon request. Where any Addition & Alteration works are carried out to the stations, the station owner shall ensure that changes in the management of fire safety provisions are updated in the Fire Safety Instruction Manual by the QP. The updated Fire Safety Instruction Manual shall be submitted to SCDF for record

CLAUSE 1.2 CODES AND STANDARDS

1.2.1 Reference

This Code makes reference to numerous local and international codes of practice and standards. Only the latest version of the codes of practice and standards shall be used for the purpose of this Code. A list of such codes of practice and standards is as shown in [Table 1.2A](#).

1.2.2 Conflicting requirements

All codes of practice and standards which this Code referred to shall be read in conjunction with the relevant clauses in this Code. Where conflict exists between this Code and the referred codes of practice and/ or standards, the requirements stipulated in this Code shall take precedence.

1.2.3 Maintenance of fire protection systems

All fire protection systems installed/ provided in a station, shall be maintained in accordance with applicable codes or standards specified in [Table 1.2A](#). The QP shall list down the maintenance details in the Fire Safety Instruction Manual and handover to the owner for compliance at the completion of the project. For the purpose of this Code, "fire protection system" has the same meaning as in the Fire Safety Act.

CLAUSE 1.3 ABBREVIATIONS

The abbreviations used in this Code are listed in *Table 1.3A*.

CLAUSE 1.4 DEFINITIONS

In this Code, unless the context otherwise requires, the following definitions will apply.

1.4.1 Accessible floor area

"Accessible floor area" refers to the total floor area of all covered spaces within a station, including service ducts, lift shafts, toilets, staircases, areas occupied by fixed/ moveable furniture/ equipment/ facilities, and any open-to-sky habitable areas above or below the first storey of the station.

1.4.2 Aboveground station

"Aboveground station" refers to a station with its trainway located at or aboveground level.

1.4.3 Aboveground trainway

"Aboveground trainway" refers to a portion of the guideway supported by elevated structure, ground level structure, embankment, or cut slope.

1.4.4 Ancillary area

"Ancillary area" refers to the non-public areas used to house or contain operating, maintenance, or support equipment and functions.

1.4.5 Area of compartment/ room/ space

"Area of compartment/ room/ space" refers to the total area of any compartment/ room/ space bounded by the inner finished surfaces of the walls that form the compartment/ room/ space. Where there is no enclosing wall on any one side, the area of the compartment/ room/ space shall be measured by the outermost edge of the floor on that side.

1.4.6 Area of refuge

"Area of refuge" refers to an area within a station or in an adjoining station where evacuees can temporarily take refuge, in lieu of the requirement for adequate exit staircase provision. It shall be adequately separated from the rest of the station or adjoining station by fire-resisting construction and connected via an external corridor or open-sided linkway. The area of refuge shall be always accessible.

1.4.7 Area of roof

"Area of roof" refers to the visible roof area on a plane parallel to the pitch of the roof.

1.4.8 Area of station

"Area of station" refers to the total area of that station bounded by the inner finished surfaces of the enclosing walls. Where there is no enclosing wall on any one side, the area of station shall be measured by the outermost edge of the floor on that side.

1.4.9 Atrium

"Atrium" refers to a large open space within a station created by an opening or a series of openings in floor assemblies, thus connecting two or more storeys. An atrium is covered at the top and is used for purposes other than those associated with small shafts e.g. stairs, elevators, and various services. The sides of the atrium can be open to all floors, to some floors, or closed to all or some floors by non-rated or rated fire-resistance construction.

1.4.10 Authority having jurisdiction

"Authority having jurisdiction" refers to non-SCDF local entities, which may include an organisation, office, or individual responsible for enforcing the requirement of a code, standard, or for approving equipment, materials, an installation, or a procedure.

1.4.11 Backlayering

"Backlayering" refers to the reversal of movement of smoke and hot gases counter to the direction of the ventilation airflow.

1.4.12 Basement storey

"Basement storey" refers to a storey of a station for which at least half the storey height is below the ground level, and which also adjoins its perimeter walls for at least half the length of such walls.

a. Exception 1:

Under-Platform Services Ducts (UPSD) and cable chambers conforming with Cl.2.2.4e. and not exceeding 2m measured from finished floor level to ceiling height shall not be considered as a basement in a transit station. The UPSD and cable chambers shall only house cables and services serving the station.

b. Exception 2:

(1) Extended landings that connect transfer exit staircases, ventilation shafts, lift and staircase landings shall not be considered a basement storey in a transit station.

(2) The extended staircase landings shall not be wider than the width of the exit staircase (to prevent other usage i.e. storage).

(3) The ventilation shafts shall not contain mechanical and electrical equipment and cables, other than those serving the shaft itself.

1.4.13 Boundary

"Boundary" refers to the border demarcating the area surrounding the station, and where applicable (in determining the relevant boundary), it includes the imaginary extension of the border up to the centre of an abutting public street, canal, or river.

1.4.14 Buffer areas

"Buffer areas" refer to unenclosed corridors located alongside train-ways beyond the ends of platform screen doors and are inaccessible to the public during normal operation hours. Where buffer areas are designated as part of egress for passengers, they shall be made accessible via the release of electromagnetic/ electromechanical device of the access doors at the ends of the platform screen doors during a fire emergency.

1.4.15 Cavity barrier

"Cavity barrier" refers to a fire-rated construction that seals or sub-divides a concealed space. The cavity barrier helps limit the spread of smoke and fire into or within that concealed space.

1.4.16 Ceiling

"Ceiling" refers to a part of a station or trainway that encloses and is exposed overhead in a room, circulation space, or protected shaft. A soffit or rooflight is included as part of its surface but, not the frame of a rooflight.

1.4.17 Circulation space

"Circulation space" refers to the means of access between a room or protected shaft and an exit from the station or compartment. It shall not be used for any commercial activity such as information and reception counter, or areas used for exhibitions.

1.4.18 Compartment

"Compartment" refers to a part of a station or trainway separated from all other parts of the same station or trainway by compartment walls and/ or compartment floors. A roof space above the top storey of a compartment is included in that compartment.

1.4.19 Compartment wall & compartment floor

"Compartment wall" and "compartment floor" refers to walls or floors of fire-rated construction provided for the purpose of dividing a rapid transit station into compartments.

1.4.20 Concealed space/ Cavity

"Concealed space/ Cavity" refers to a space enclosed by elements of a station (including a suspended ceiling or raised floor) or contained within an element. It is not a room, cupboard, circulation space, protected shaft or space within a flue, chute, duct, pipe, or conduit.

1.4.21 Corridor

"Corridor" refers to a passage providing means of access from rooms or spaces to an exit.

1.4.22 Critical velocity

"Critical velocity" refers to the minimum steady-state velocity of ventilation airflow moving towards the fire within a tunnel or passageway that is required to prevent backlayering at the fire site.

1.4.23 Cubical extent

"Cubical extent" refers to the volume of a space within a station or compartment. This excludes protected lift walls, exit staircases, and other accommodation (such as restrooms and locker rooms) which are enclosed with walls having at least 1-hr fire resistance, and openings protected by doors of ½-hr fire resistance fitted with an automatic self-closing device. It shall be measured according to the following dimensions:

a. The inner finished surfaces of the enclosing walls or on any side where there are no enclosing walls a plane extending vertically above the outermost edge of the floor on that side;

b. The upper surface of its lowest floor; and

c. Where a station or compartment extends to a roof, the under surface of the roof or the under surface of the ceiling of the highest storey within the compartment, including space occupied by any other walls, or any unprotected shafts, ducts, or structures within the spaces to be so measured.

1.4.24 Dead-end

“Dead-end” refers to a situation within a space, normally a corridor or lift lobby spaces where exit is only possible from one end, with no possible escape from the other end.

1.4.25 Direct distance

“Direct distance” refers to shortest distance from the most remote point in a room or space, measured within the external enclosures of the room or space to the relevant exits, ignoring internal walls, partitions, and fittings other than the enclosure walls of exit passageways and exit staircases.

1.4.26 Door

“Door” refers to any shutter, cover, or other form of protection to an opening in any wall, floor, or in the structure surrounding a protected shaft regardless of whether the door is constructed of one or more leaves.

1.4.27 Electromagnetic or Electromechanical locking device

“Electromagnetic” or “Electromechanical locking device” refers to an electrically powered fail-safe device which provides egress access control.

1.4.28 Element of structure

“Element of structure” refers to:

- a. a member forming part of the structural frame of a station, trainway, or any other beam or column but not a member forming part of a roof structure only, or
- b. a load-bearing wall or load bearing part of a wall, or
- c. a floor, including a compartment floor, other than the lowest floor (in contact with the ground), or
- d. a separating wall, or
- e. a structure enclosing a protected shaft (protecting structure).

1.4.29 Emergency lighting

“Emergency lighting” refers to lighting provided with a secondary source of power supply to illuminate the exits and spaces within a station.

1.4.30 Engineering analysis

“Engineering analysis” refers to an analysis that evaluates all factors that affect the fire safety of the system. A report of the analysis indicating the proposed method(s) providing a level of fire safety commensurate with this Code shall be submitted.

1.4.31 Enclosed station

“Enclosed station” refers to a station or portion thereof that does not meet the requirements of an open station.

1.4.32 Exit

“Exit” refers to a means of egress from the interior of the station or trainway to an exterior space. An exit is by the use of the following either singly or in combination: exterior door openings, exit staircases, exit ramps, or exit passageways but not including access stairs, aisles, corridor doors, or corridors. In the case of ancillary area and commercial space in stations are present, exit also include door opening directly to the station public area.

1.4.33 Exit access

“Exit access” refers to the portion of a means of escape that leads to an exit. It includes the room and station spaces that people occupy, the doors along the escape routes, lobbies, aisles, passageways, corridors, access stairs, and ramps traversed in order to reach an exit.

1.4.34 Exit access door

“Exit access door” refers to a door which provides access to a room or space excluding a toilet cubicle, bedroom, storeroom, utility room, pantry and the like, or installed across the escape path leading to an exit.

1.4.35 Exit door

“Exit door” refers to a door provided at the doorway of an exit for the passage of people, forming part of the integrity of the exit, including the exterior door opening.

1.4.36 Exit lighting

“Exit lighting” refers to the part of emergency lighting that is provided to illuminate the exits.

1.4.37 Exit passageway

“Exit passageway” refers to the horizontal extension of a vertical exit via exit staircase or a passage leading from a habitable area to the station public area or an open exterior space.

1.4.38 Exit staircase

“Exit staircase” refers to a staircase constructed of non-combustible material and protected from fire (by fire-rated construction or located at the external space) for the purpose of enabling egress to the external space.

1.4.39 External exit staircase

“External exit staircase” refers to an exit staircase located outside the station, open to the external space, and that:

- a. is enclosed by parapet walls or railing of not more than 1.1m in height;
- b. has at least two adjacent sides or one of its longest sides abutting the external space; and
- c. is recessed not more than 3m from the station façade.

1.4.40 External exit passageway

“External exit passageway” refers to an exit passageway that serves as required exit with at least one of its longest sides open to the external space or air well.

1.4.41 External wall finishes

“External wall finishes” refers to materials/ components installed on the station facade for the purpose of providing thermal insulation, weather resistance and/ or to improve the appearance of stations. They can be made of metal, brick/ stone granite, composite materials, etc. It shall include cladding, fins, and any decorative features mounted on the external walls of a station.

1.4.42 External wall (or side of a station)

“External wall (or side of a station)” refers to an outer wall or vertical enclosure. This includes a part of the roof pitched at an angle of 70° or more to the horizontal if that part of the roof adjoins a space within the station to which persons have access.

1.4.43 Firefighting staircase

“Firefighting staircase” refers to an exit staircase that has its enclosure constructed of non-combustible material and shall have a fire resistance of not less than that for the element of structure and designated for use by firefighters.

1.4.44 Fire lift lobby

“Fire lift lobby” refers to a protected and ventilated/ pressurised lobby into which a fire lift opens and from which direct access to a protected staircase can be made for the purpose of firefighting.

1.4.45 Fire resistance

“Fire resistance” refers to the minimum time period during which an element of structure or element of a station/ trainway can be expected to function satisfactorily while subjected to a standard fire test.

1.4.46 Fire stop

“Fire stop” refers to a seal provided to close an imperfection of fit or any joint between elements, components, or construction in a station, which serves to prevent/ limit the passage of smoke and flame through that imperfection or joint.

1.4.47 Guideway

“Guideway” refers to the portion of the transit line within right-of-way fences, outside lines of curbs or shoulders, underground tunnels, cut or fill slopes, ditches, channels and waterways, and including all appertaining structures.

1.4.48 Habitable floor

“Habitable floor” refers to all floors in a station, including the roof level. The roof level can be taken as non-habitable if it is not used for any purpose/ activity other than housing M&E plants/

equipment, e.g. lift motors, fire pumps, generators, fire hose reel pumps, water supply pumps, water tanks, cooling towers, solar photovoltaic panels, supply/ exhaust fans with associated ductwork, air-con condensing units, telecommunication equipment, satellite dishes, public warning sirens, green roofs inaccessible to public and for maintenance access only, etc.

1.4.49 Habitable height

"Habitable height" refers to the height measured from the level of fire engine accessways or fire engine access roads, whichever is the lowest, to the finished floor level of the highest habitable floor.

1.4.50 Heat release rate

"Heat release rate" refers to energy evolved under a given fire scenario expressed as a function of time.

1.4.51 Height of station

Height of station or part of a station refers to the vertical distance measured from the average level of the ground adjoining the outside of the external walls of the station to the level of half the vertical height of the roof of the station or part, or the top of the walls or of the parapet (if any), whichever is higher.

1.4.52 High hazard occupancy

"High hazard occupancy" refers to any occupancy in which the contents or activities include one or more of the following:

- a. material with auto-ignition temperature lower than 200°C, or
- b. materials that produce poisonous, noxious fumes, or flammable vapour, or
- c. materials that cause explosions, or
- d. high hazard occupancies classified under SS CP 52, or
- e. highly combustible substances and flammable liquids.

1.4.53 Load bearing wall

"Load bearing wall" refers to a wall that supports any load in addition to its own weight.

1.4.54 Masonry

"Masonry" refers to brick or concrete construction.

1.4.55 Mechanical ventilation

"Mechanical ventilation" refers to any system that uses mechanical means such as ventilation fan, to introduce outdoor air to a space when natural ventilation mode cannot be achieved during normal and fire emergency situations. This includes supply ventilation, exhaust ventilation, pressurisation, smoke purging, mechanical engineered smoke control systems, balanced systems that consist of both supply and exhaust ventilations, etc.

1.4.56 Non-combustible material

"Non-combustible material" refers to any material which neither burns nor gives off flammable vapour in sufficient quantity to ignite when subjected to the test for combustibility prescribed in BS 476 Part 4, and includes materials of limited combustibility, such as:

- a. any material of density 300 kg/m³ or more, which when tested in accordance with BS 476: Part 11, does not flame, and the rise in temperature on the furnace thermocouple is not more than 20°C;
- b. any material with a non-combustible core at least 8mm thick having combustible facings (on one or both sides) not more than 0.5mm thick; and
- c. any material of density less than 300 kg/m³, which when tested in accordance with BS 476: Part 11,
 - (1) does not flame for more than 10 sec;
 - (2) the rise in temperature on the centre (specimen) thermocouple is not more than 35°C; and
 - (3) the rise in temperature on the furnace thermocouple is not more than 25°C.

1.4.57 Non-load bearing wall

"Non-load bearing wall" refers to a wall that supports no load other than its own weight.

1.4.58 Non-transit occupancy

"Non-transit occupancy" refers to an occupancy not related to the operation of rapid transit systems.

1.4.59 Notional boundary

"Notional boundary" refers to an imaginary boundary which exists at equal distance between buildings/ stations on the same site, or the centre of the width of a public road/ drain/ sewer reserve, provided that the boundary is fronting the respective reserves.

1.4.60 Occupant load

"Occupant load" to a station, or part thereof, refers to the total number of persons that can occupy such a station, or part thereof, at any one time. The "occupant load" shall be determined via the floor area(s) available for occupant based on the appropriate areas per person as stated in [Table 1.4.60](#).

1.4.61 Open station

"Open station" refers to a station that is exposed to the atmosphere where heat and smoke from a train fire are allowed to disperse directly into the atmosphere.

1.4.62 Operation Control Centre (OCC)

"Operation Control Centre (OCC)" refers to a room where the transit system operator controls and coordinates the system-wide movement of passengers and trains. It is here from which communication is maintained with supervisory and operating personnel and with participating agencies when required.

1.4.63 Passenger Service Centre (PSC)

"Passenger Service Centre (PSC)" refers to the room located in a station where communication with the OCC, trains, passengers, and members of the public can be conducted.

1.4.64 Permitted limit of unprotected area

"Permitted limit of unprotected area" refers to the maximum aggregate of unprotected areas in any side or external wall of a station or compartment.

1.4.65 Point of safety

"Point of safety" refers to an enclosed fire exit that leads to a safe location outside the structure, an at-grade point beyond any enclosing structure, or another area that affords adequate protection for passengers.

1.4.66 Pressurisation

"Pressurisation" refers to a mechanical ventilation system that introduce positive differential pressure to a space/ room to prevent smoke ingress during a fire emergency.

1.4.67 Protected shaft

"Protected shaft" refers to an exit staircase, exit passageway, lift, chute, duct, or other shaft which enables persons, things, or air to pass from one compartment to another.

1.4.68 Protecting structure

"Protecting structure" refers to a wall, floor, or other part of the station or trainway which encloses a protected shaft. It is not:

- a. A wall which also forms part of an external wall, separating wall or compartment wall, or
- b. A floor which is also a compartment floor, or a floor laid directly on the ground, or
- c. A roof.

1.4.69 Public area

"Public area" refers to any part of the station normally accessible by members of the public. It includes pedestrian linkways connected to the station.

1.4.70 Railway

"Railway" means a network or system of fixed horizontal rails, tracks, grooves, or other guideway on, under, or above the ground along which a train moves or runs and includes all tunnels, viaducts, bridges, crossings, stabling yards, depots, stations, and other infrastructures constructed or intended to be constructed for any railway and any extensions thereto.

1.4.71 Rapid Transit System (RTS)

"Rapid Transit System (RTS)" means any railway line, or a combination of 2 or more railway lines, and any part thereof comprised in that line, or those lines set up under this Act (Rapid Transit Systems) to meet the transport requirements of the public and includes the Mass Rapid Transit system set up under the repealed Act (Rapid Transit Systems).

1.4.72 Relevant boundary

"Relevant boundary" refers to a boundary in relation to a side or external wall of a station/ building or compartment, including a notional boundary.

1.4.73 Roof light

"Roof light" refers to any element in a roof intended to admit daylight.

1.4.74 Room

"Room" refers to an enclosed space though not an enclosed circulation space, protected shaft, or an enclosed space at most 750mm in depth.

1.4.75 Separated part (of a station)

"Separated part (of a station)" refers to a form of compartmentation separated from another part of the same station by a compartment wall which runs full height of the part and is in one continuous plane.

1.4.76 Separating wall

"Separating wall" refers to a wall dividing or portioning adjoining buildings/ stations.

1.4.77 Singapore Civil Defence Force (SCDF)

"Singapore Civil Defence Force (SCDF)" refers to the Commissioner of Singapore Civil Defence Force and includes officers authorised by him generally or specifically to exercise the powers, functions, and duties conferred by the Fire Safety Act.

1.4.78 Smoke-free lobby

"Smoke-free lobby" refers to a lobby located at the entrance to an exit staircase. This exists to help to prevent or minimise the entry of smoke into the staircase.

1.4.79 Station

"Station" refers to a place designated for the purpose of boarding and alighting passengers. This includes public areas, commercial spaces, ancillary area, and trainway associated with the same structure.

a. Stations with multiple transit lines are stations with one or more train platforms and concourse public areas serving different transit lines within a station.

b. Stations with interchange-link are stations provided with direct transfer between transit lines.

c. Stations connected to non-transit occupancy are stations with:

- (1) A pedestrian link connected to non-transit occupancies, and/ or
- (2) Station entrance integrated with non-transit occupancies.

1.4.80 Station platform

"Station platform" refers to the area of a station used primarily by passengers boarding and alighting trains. See [Diagram 1.4.80](#).

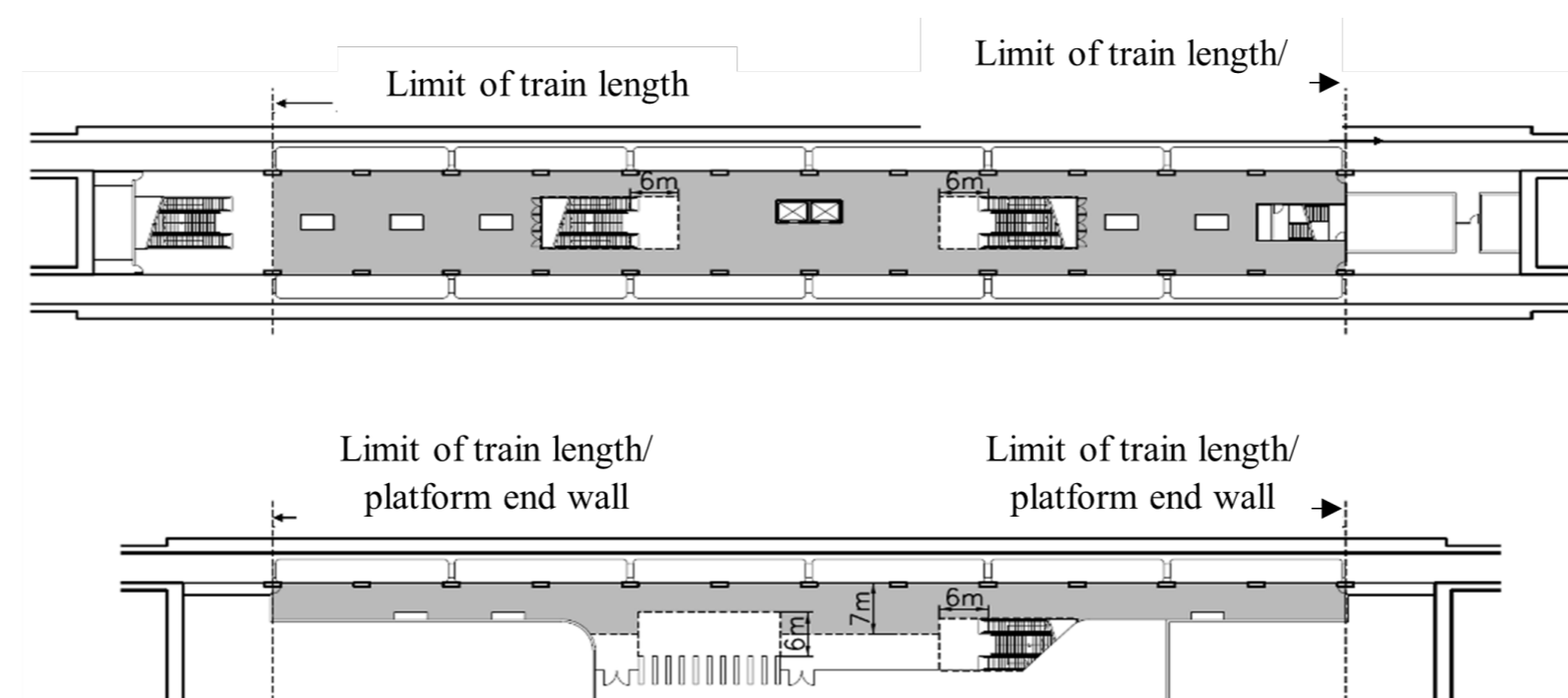

Diagram 1.4.80: Layout of Station Platform

1.4.81 Trades and services

Type of trades and services permitted in station commercial spaces are stated in [Table 1.4A](#).

1.4.82 Trainway

"Trainway" refers to the portion of the guideway where the transit vehicles operate.

1.4.83 Train-peak load

"Train-peak load" refers to the full seating and standing capacities that a train can carry, specified in [Table 1.4.83](#).

1.4.84 Transit station

"Transit station" refers to station accommodating only passengers and employees of the RTS and incidental occupancies in the station.

1.4.85 Underground station

"Underground station" refers to a station with its trainway located in the basement storey.

1.4.86 Unprotected area

"Unprotected areas", in relation to a side or external wall of a station refers to:

- a. a window, door, or other opening; and
- b. any part of the external wall which has less than the relevant fire resistance.

1.4.87 Ventilation openings

"Ventilation openings" refer to fixed natural ventilation openings located in external walls for any space, which shall be always unobstructed, and exclude windows or louvres that are openable or operable. Where fixed louvres are used in natural ventilation openings for exit staircases, smoke-free lobbies or exit passageways they shall consist of a single bank of louvres with blade width not exceeding 150mm, with effective ventilation openings calculated based on the free area calculation stated in [Diagram 1.4.87](#).

1.4.88 Vertical exit

"Vertical exit" refers to an exit staircase or exit ramp serving as required exit from one or more storeys above or below ground level.

1.4.89 Wall surface

"Wall surface", in the context of internal surfaces, refers to the surface of glazing, and any part of the ceiling sloping at an angle of 70° or more to the horizontal. It does not include:

- a. door frames and unglazed parts of doors, or
- b. window frames and frames in which glazing is fitted, or
- c. architraves, cover moulds, picture rails, skirtings, and similar narrow members, or
- d. fitted furniture.

Diagram 1.4.87: Ventilation Opening Size

Ventilation opening size for single bank louvres = Free Area = L [A + C + (B x n)]

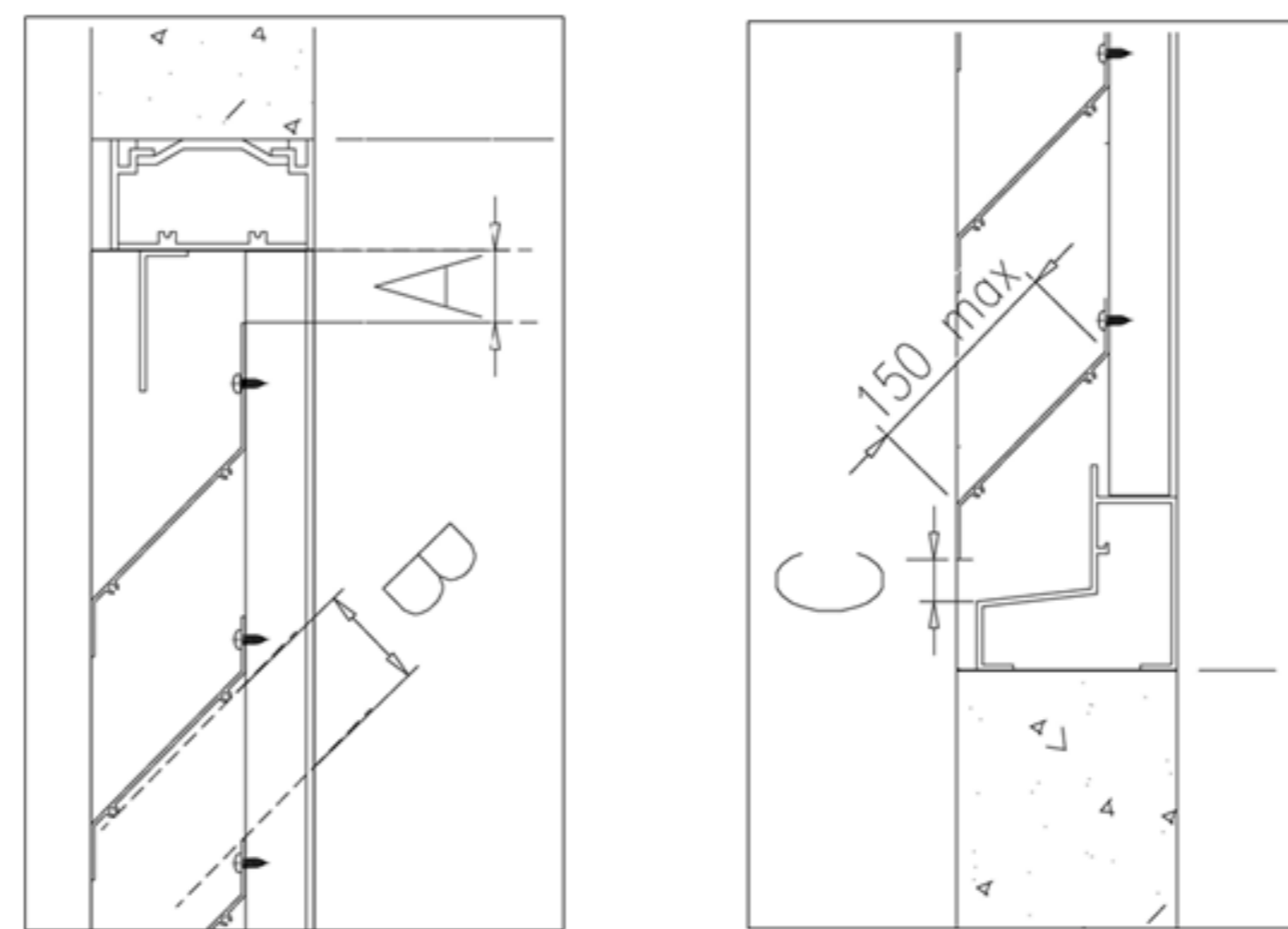
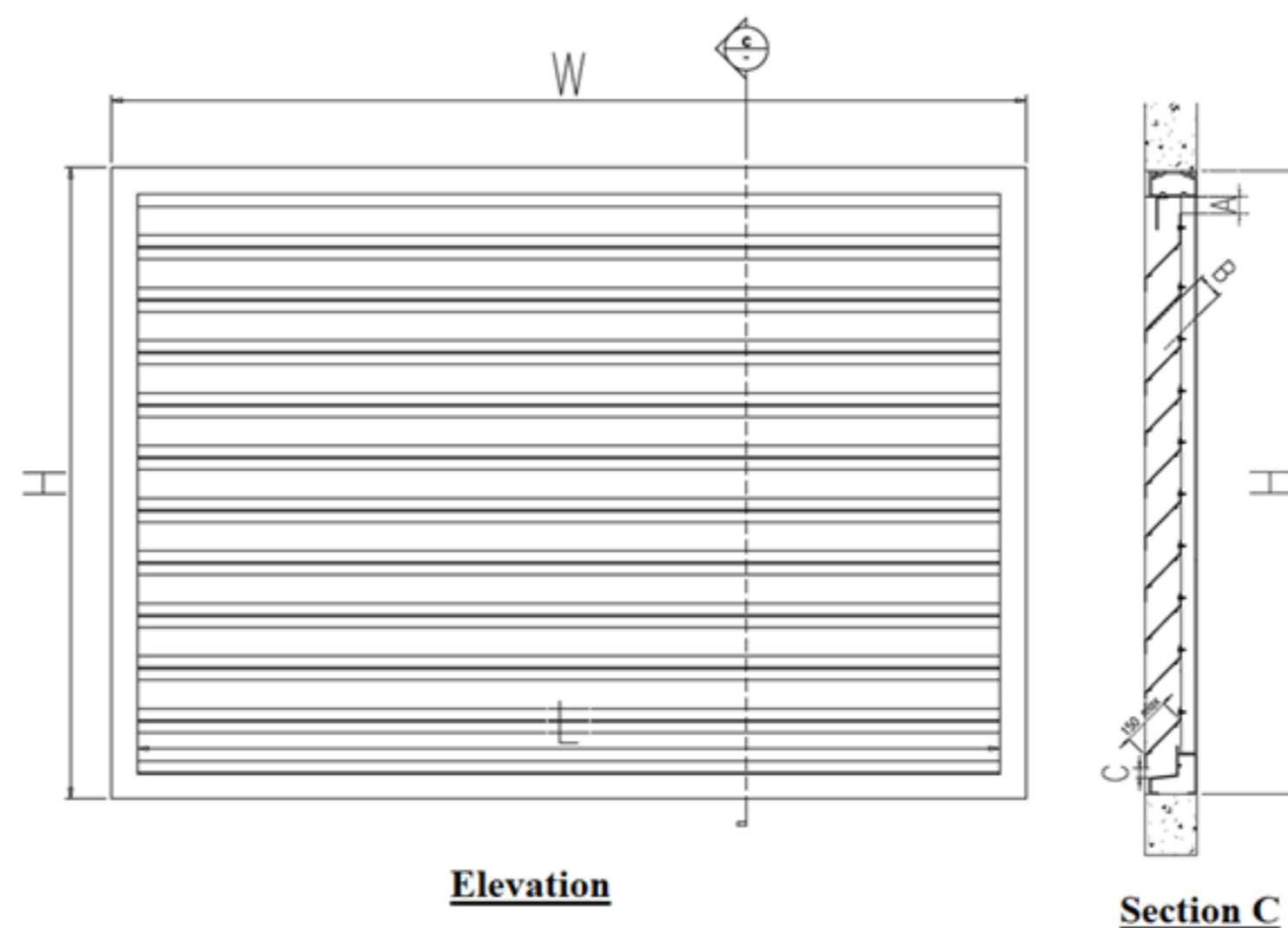

A = Min opening distance between the top frame and top blade
 C = Min distance between the sill and bottom blade
 B = Min distance between blades
 n = Number of B openings
 L = Min distance between louvres jambs

Diagram 1.4.87: Ventilation Opening Size

TABLE 1.4.60 - Occupant Load Factors

TABLE 1.4.60 – Occupant Load Factors		
Functional Spaces	Factor (m2/person)	Remarks
Station platform areas	0.5¹	
Shops	5	
Bicycle kiosk	5	
Office	10	
Operation Control Centre	10	
Passenger Service Centre	10	
Store room	10	
Bicycle parking area	30	
Bicycle parking area	30	
Pedestrian linkway/ Concourse	*	non-simultaneous
Lobby/ corridor/ staircase	*	non-simultaneous
Toilets	*	non-simultaneous
Staff room/ Locker room	*	non-simultaneous
Note: * – Non-simultaneous (not considered for occupant load calculation) 1 – For train peak load, it shall include: train fully seated train car standing areas to compute as 4 passengers/m ² For train peak load by train type and car length – refer to Table.1.4.83		

TABLE 1.4.83 - Train Peak Load

TABLE 1.4.83 – Train Peak Load			
Train Type	Train Car length (m)	Number of Train Cars*	Train Peak Load
LRT	~12	1	88
		2	176
MRT	~19	3	4
		450	600

MRT	~23	3	670
		4	890
		6	1340
		8	1780
Note:			
* – Train Peak Load for any total train cars not listed here will be multiply/ proportion according to respective train type and car length			

TABLE 1.2A: CODES & STANDARDS

TABLE 1.2A: CODES & STANDARDS		
Name	Description	Remarks
SINGAPORE STANDARDS		
SS CP 52	CoP for Automatic Fire Sprinkler System	
SS 299	Fire Resistant Cables	
SS 332	Specification for Fire Door	
SS 489	Specification for Fire Shutters	
SS 508	Graphical Symbols – Safety Colours & Safety Signs	Formerly SS 217 & SS 364
Pt 1	Design Principles for Safety Signs & Safety Markings	
Pt 2	Design Principles for Product Safety Labels	
SS 546	CoP for Emergency Voice Communication Systems in Buildings	Formerly CP 25
SS 550	CoP for Installation, Operation and Maintenance of Electric Passenger and Goods Lifts	Formerly CP 2
SS 551	CoP for Earthing	Formerly CP 16
SS 563	CoP for the Design, Installation & Maintenance of Emergency Lighting and Power Supply Systems in Building	Formerly CP 19
Pt 1	Emergency lighting	
Pt 2	Installation Requirements and Maintenance Procedures	
SS 575	CoP for Fire Hydrant, Rising Mains and Hose Reel System	Formerly CP 29
SS 578	CoP for the Use and Maintenance of Portable Fire Extinguishers	Formerly CP 55
SS 638	Code of Practice for Electrical Installations	Formerly CP 5
SS 645	CoP for Installation and Servicing of Electrical Fire Alarm System	Formerly CP 10
SS EN 3	Specification for Fire Extinguishers	
SS EN 1992	Design of Concrete Structures	Formerly CP 65
Pt 1	General Rules and Rules for Buildings	
Pt 2	Concrete Bridges – Design and Detailing Rules	
AMERICAN STANDARDS		
ANSI	American National Standards Institute	
A14.3	American National Standard for Ladders – Fixed – Safety Requirements	
AUSTRALIAN STANDARDS		
AS 2208	Safety Glazing Materials in Buildings	
BRITISH STANDARDS		
BS 476	Fire Tests on Building Materials and Structures	
Pt 4	Non-Combustibility Test for Materials	
Pt 5	Method of Test for Ignitability	
Pt 6	Method of Test for Fire Propagation for Products	
Pt 7	Method of Test to Determine the Classification of the Surface Spread of Flame of Products	
Pt 11	Method for Assessing the Heat Emission from Building Materials	
Pt 20	Method for Determination of the Fire Resistance of Elements of Construction (General Principles)	
Pt 21	Methods for Determination of the Fire Resistance of Load-Bearing Elements of Construction	
Pt 22	Method for Determination of the Fire Resistance of Non-Load-Bearing Elements of Construction	
Pt 23	Methods for Determination of the Contribution of Components to the Fire Resistance of a Structure	
Pt 24	Method for Determination of the Fire Resistance of Ventilation Ducts	
BS 1230: Pt 1	Specification for Plasterboard Excluding Materials Submitted to Secondary Operations	Replaced by BS EN 520
BS 4514	Specification for Unplasticized PVC Soil and Ventilating Pipes of 82.4mm Minimum Mean Outside Diameter, and Fittings and Accessories of 82.4mm and of Other Sizes	
BS 5234	Partitions (including matching linings)	
Pt 2	Specification for Performance Requirements for Strength and Robustness including Methods of Test	

BS 5395: Pt 3	Stairs, Ladders and Walkways. Code of Practice for the Design of Industrial Type Stairs, Permanent Ladders and Walkways	
BS 5499	Fire Safety Signs, Notices and Graphic Symbols	
Pt 2	Specification for Performance Requirements for Strength and Robustness including Methods of Test	Withdrawn
BS 5588	Fire Precautions in the Design, Construction and Use of Buildings	
Pt 5	CoP for Firefighting Stairways and Lifts	
BS 6206	Specification for Impact Performance Requirements for Flat Safety Glass and Safety Plastics for Use in Buildings	Replaced by EN 12600
BS 6391	Specification for Non-Percolating Layflat Delivery Hoses and Hose Assemblies for Fire Fighting Purposes	
BS 8202	Coatings for Fire Protection of Building Elements	
Pt 2	CoP for the Use of Intumescent Coating Systems to Metallic Substrates for Providing Fire Resistance	
BS EN 1329	Plastics Piping Systems for Soil and Waste Discharge (Low and High Temperature) within the Building Structure	
Pt 1	Unplasticized Poly (Vinyl Chloride) (PVC-U) – Specifications for Pipes, Fittings and the Systems	
IEC STANDARDS		
IEC 60331	Tests for Electric Cables Under Fire Conditions – Circuit Integrity	
Pt 25	Procedures and Requirements – Optical Fibre Cables	
IEC 60332	Tests on Electric and Optical Fibre Cables Under Fire Conditions – All Parts	
Pt 1	Test for Vertical Flame Propagation for a Single Insulated Wire or Cable – Apparatus	
Pt 3	Test for Vertical Flame Spread of Vertically-Mounted Bunched Wires or Cable – Apparatus	
IEC 61034	Measurement of Smoke Density of Cables Burning Under Defined Conditions	
IEC 60754	Test on gases Evolved during Combustion of Materials From Cables	
Pt 1	Determination of the Halogen Acid Gas Content	
ISO STANDARDS		
ISO 1896	Thermal Insulating Asbestos Boards	
Note:		
- The Standards stated above are non-exhaustive.		
- SCDF shall not be held responsible for the accuracy of the standard titles shown in this table..		

TABLE 1.3A: ABBREVIATIONS

TABLE 1.3A: ABBREVIATIONS	
Abbreviation	Definitions
ACMV	Air-Conditioning & Mechanical Ventilation
AFA	Accessible Floor Area
ANSI	American National Standards Institute
AS	Australian Standards
BS	British Standard
CD	Civil Defence
Cl.	Clause
CoP	Code of Practice
CPFPRTS	Code of Practice for Fire Precautions in Rapid Transit Systems
FCC	Fire Command Centre
HR	Hour
IEC	International Electrotechnical Commission
ISO	International Organisation for Standardisation
LED	Light-Emitting Diode
OCC	Operation Control Centre
PSC	Passenger Service Centre
PV	Photo-Voltaic
PVC	Polyvinyl Chloride
PWDs	Persons With Disabilities
QP	Qualified Person
RTS	Rapid Transit System
SCDF	Singapore Civil Defence Force

SS	Singapore Standard
TV	Tunnel Ventilation
TVF	Tunnel Ventilation Fan
UPSD	Under-Platform Service Ducts

TABLE 1.4A: APPROVED TRADES & SERVICES IN STATIONS

TABLE 1.4A: APPROVED TRADES & SERVICES IN STATIONS			
Code	Grouping	Type	
A	General	24 hours convenience store	
	Merchandise	Mini mart/ provision shop	
B	Clothing & Shoes	Children's wear/ accessories	
		Fashion accessories	
C	Household Supplies	Hardware/ DIY shop(1)	Household ware/ utensils
		Home furnishing centre(1)	
D	Other Retail	Arts/ antiques	Name cards
		Bridal saloon/ shop	Perfume
		Chinese medical hall	Sports/ golf
		Clock	Telecommunications
		Electrical goods	Video library/ Cassettes/ CD/ VCD/ Fruits Laser Disc/ DVD
		Fruits	
E	Financial	Bank/ auto lobby	
F	Services		
		Acupuncture	LAN game/ internet café
		Child adoption agency	Medical/ dental clinic
		Counselling centre	Pawnshop
		Copying and duplicating services	Renovation contractor showroom
		Fitness centre	Therapy/ osteopathy/ chiropractic centre
		Hairdressing/ beauty salon	Toys/ toy collectibles shop
		Hand phone repair centre	Wellness centre/ spa
		Internet service provider	Yoga/ martial arts school
		Video games arcade, computer gaming centre, billiard saloon	
G	Food & Beverages	Café(2)	Snack bars(2)
		Cake/ confectionery/ pastryshop(2)	Takeaway food and beverages shop(2)
		Fast food kiosk(2)	Titbits/ candies/ biscuits
H	Bicycle parking area(3)	Bicycle kiosk(1), (3) with activities confine to bicycle servicing, repairs, cleaning, sale of bicycle accessories and spare parts	

Note:

- (1) - There shall be no sale or storage of paint, solvent, thinner and bicycle batteries. Charging of bicycle batteries is not allowed in the bicycle parking area or bicycle kiosk.
- (2) - For the Food and Beverage outlets, there shall be no open-flame.
- (3) - The underground bicycle area is excluded from the 115m² aggregated size for shop as permitted in Cl.3.2.4c.(2).

Clause No.	Amendment Date	Effective Date	Clause Status	Clause Before Amendment	Circular Date
------------	----------------	----------------	---------------	-------------------------	---------------

CLAUSE 2.1 GENERAL

The provisions of this Chapter shall serve to express the intentions for determining the design, construction, protection, location, arrangement, and maintenance of exit facilities to provide safe means of escape for occupants. Areas which are designated as means of escape such as exit staircase, fire lift lobby, smoke-free lobby, exit passageway, and escape corridor shall not be turned into other usage.

CLAUSE 2.2 DETERMINATION OF EXIT REQUIREMENTS

2.2.1 General

The primary purpose of a station is for the use of the transit passengers who normally stay in a station for a period. It shall be no longer than the time necessary to wait for and enter a departing transit vehicle or to exit the station after arriving on an incoming transit vehicle.

2.2.2 Occupant load

a. Occupant load for transit station



Except as required in [Cl.2.2.2d](#), the occupant load for a transit station shall be calculated based on $0.5\text{m}^2/\text{person}$ applied across all the station platform areas in accordance with [Cl.2.2.2b](#), plus the single train-peak load calculated in accordance with [Table 14.83](#).

Rationale

The occupant load of 0.5m^2 per person is derived based on the Level of Service figure. This is a set of qualitative measures that the operators are required to adhere to in relation to quality of traffic service in the transport industry as illustrated in the diagram below. It is also commonly used in evacuation modelling to assess whether the situation is crowded or congested. It takes into account the addition of a single train peak load and the event where there may be a mixed train. It is the maximum allowable number of persons in the station in order for the operator to adhere to the necessary service.

This revised method based on 0.5m^2 per person in computing occupant load for transit station will address the maximum permissible number of commuters at the platform during peak travel or unforeseen surge in ridership, in any particular transit station due to changing travel needs. It reflects the actual situation and shall not compromise lift safety during a fire emergency. It is a more reliable measure of the potential capacity that the platform can hold.

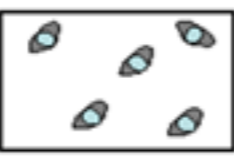
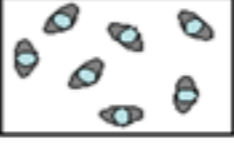
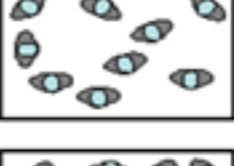
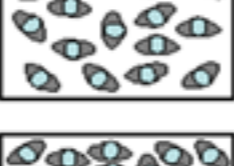
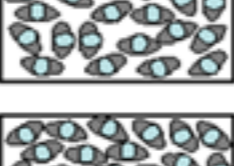
Explanation and Illustrations

Level Of Service A Average Pedestrian Space > $1.2\text{ m}^2/\text{p}$ Standing and free circulation through the queuing area is possible without disturbing others within the queue.	
Level Of Service B Average Pedestrian Space > $0.9 - 1.2\text{ m}^2/\text{p}$ Standing and partially restricted circulation to avoid disturbing others in the queue is possible.	
Level Of Service C Average Pedestrian Space > $0.6 - 0.9\text{ m}^2/\text{p}$ Standing and restricted circulation through the queuing area by disturbing others in the queue is possible; this density is within the range of personal comfort.	
Level Of Service D Average Pedestrian Space > $0.3 - 0.6\text{ m}^2/\text{p}$ Standing without touching is possible; circulation is severely restricted within the queue and forward movement is only possible as a group; long-term waiting at this density is uncomfortable.	
Level Of Service E Average Pedestrian Space > $0.2 - 0.3\text{ m}^2/\text{p}$ Standing in physical contact with others is unavoidable; circulation in the queue is not possible; queuing can only be sustained for a short period without serious discomfort.	
Level Of Service F Average Pedestrian Space $\leq 0.2\text{ m}^2/\text{p}$ Virtually all persons within the queue are standing in direct physical contact with others; this density is extremely uncomfortable; no movement is possible in the queue; there is potential for panic in large crowds at this density.	

b. Stations with multiple platforms

For station with multiple platforms, separate scenarios shall be developed with each platform separately considered as the incident platform and all other platforms considered as non-incident platforms.

- (1) The incident platform occupant load shall be calculated in accordance with [Cl.2.2.2a](#); and
- (2) All other non-incident platform occupant loads shall be based on $0.5\text{m}^2/\text{person}$ of the platform area in accordance with [Cl.2.2.2c](#).

Refer to [Cl.2.3](#) for occupant load calculations of typical stations with multiple platforms.

Rationale

These measures are necessary in order to determine if certain platforms may cause commuters to take a longer time to exit the station due to the ratio of the number of exits and the occupant load.

c. Station platform area

- (1) For the purpose of calculating the maximum occupant load, the station platform area shall be the standing area measured to the limit of the train length or to the platform end wall, whichever is shorter, and bounded by the following:
 - (a) the platform screens/ fixed panels along the platform edges; and
 - (b) 7m boundary parallel to the platform screen/ fixed screens for side platforms (platforms serving only one track).See [Diagram 1.4.80](#).
- (2) Where the station platform shares the same floor as the paid concourse, the station platform area shall include any paid concourse area up to 7m from the platform screen/ fixed screens.
- (3) The station platform area shall exclude the following:
 - (a) Any obstructions including lift shafts, voids, escalators, staircases, seats, areas with headroom less than 2m, rooms, booths, signage, artwork, and railings.
 - (b) Run-off zones directly in front of escalators and staircases measured 6m from the comb plate for any escalator or last riser for any staircases (whichever is extended further).
 - (c) Run-off zones directly in front of fare collection gates and turnstiles measured 6m from frontage of the gates or turnstiles

d. Commercial spaces and ancillary areas occupant load

Where there are commercial spaces and ancillary areas in the station,

- (1) Occupant load for the commercial spaces shall be determined in accordance with [Table 2.2.2d](#);
- (2) Occupant load in the ancillary areas (excluding E&M rooms) shall be determined based on 10m^2 of floor area per person; and
- (3) Occupant load in the commercial spaces and ancillary areas (excluding E&M rooms) shall be included in determining the required egress capacity where means of escape from that floor area converge with means of escape serving other station floor areas.

Rationale

These areas must be included because their occupant load will contribute to the time taken to exit the station. Since the same exit staircases and escalators are used, the occupant load will have a direct impact on the calculation of the exit time.

2.2.3 Means of escape from platform public area to point of safety

a. Each platform public area shall be served by at least two means of escape which are independent of and remote from each other from the platform to the exterior of the station. Where the exit staircases are located inside the buffer areas, their locations shall be prominent to the platform passengers by means of exit signs and strobe lights.

b. Fire safety requirements for Persons with Disabilities (PWDs)

The fire safety requirements for the safe evacuation of PWDs during fire emergency in the station shall be provided.

Rationale

The provision of at least two means of escape is necessary to ensure that exit is possible even in the event where one means of escape is cut-off. The buffer area is typically located in areas trainways normally not accessible to the public. Taking the behavioural patterns of commuters into consideration, commuters are likely to exit and enter stations through the same entrance. Therefore, it is likely that they will be unaware of an alternate exit route through the buffer area. A prominent sign is thus necessary to serve as a means of awareness during evacuation.

c. Stairs and escalators

(1) The stairs (excluding internal exit staircases) and escalators need not be enclosed and shall be included in the exit capacity calculation. Except for stairs at station entrance on ground level, handrails for these stairs shall also comply with [Cl.2.2.10f.](#)

Rationale

Unenclosed stairs and escalators can be used for exit capacity computation because the transit stations are transient spaces with low combustible loads.

(2) Escalators

- (a) Escalators not fire-separated from the public floor area shall be considered as contributing to the means of escape capacity.
- (b) Escalators shall not account for more than 50% of the exit capacity at any one level, including the concourse levels and mezzanine levels.

Rationale

Escalators are permitted to be considered as means of escape in transit stations as floor areas in the vicinity of escalators are reasonably free of combustibles.

Exception: Levels consisting only landings that connect escalators and stairs.

- (c) Due to the possibilities of maintenance or malfunction, one escalator at each station shall be considered as being out of service in calculating egress requirements. The escalators chosen shall be the one having the most adverse effect upon exiting capacities.
- (d) The width of the escalator shall be the width of the step tread.
- (e) Escalators shall be provided with flat steps at landings which increase in number proportionally with the rise of the escalator as shown in [Table 2.2.3c.\(2\)\(e\)](#).

Explanation and Illustrations

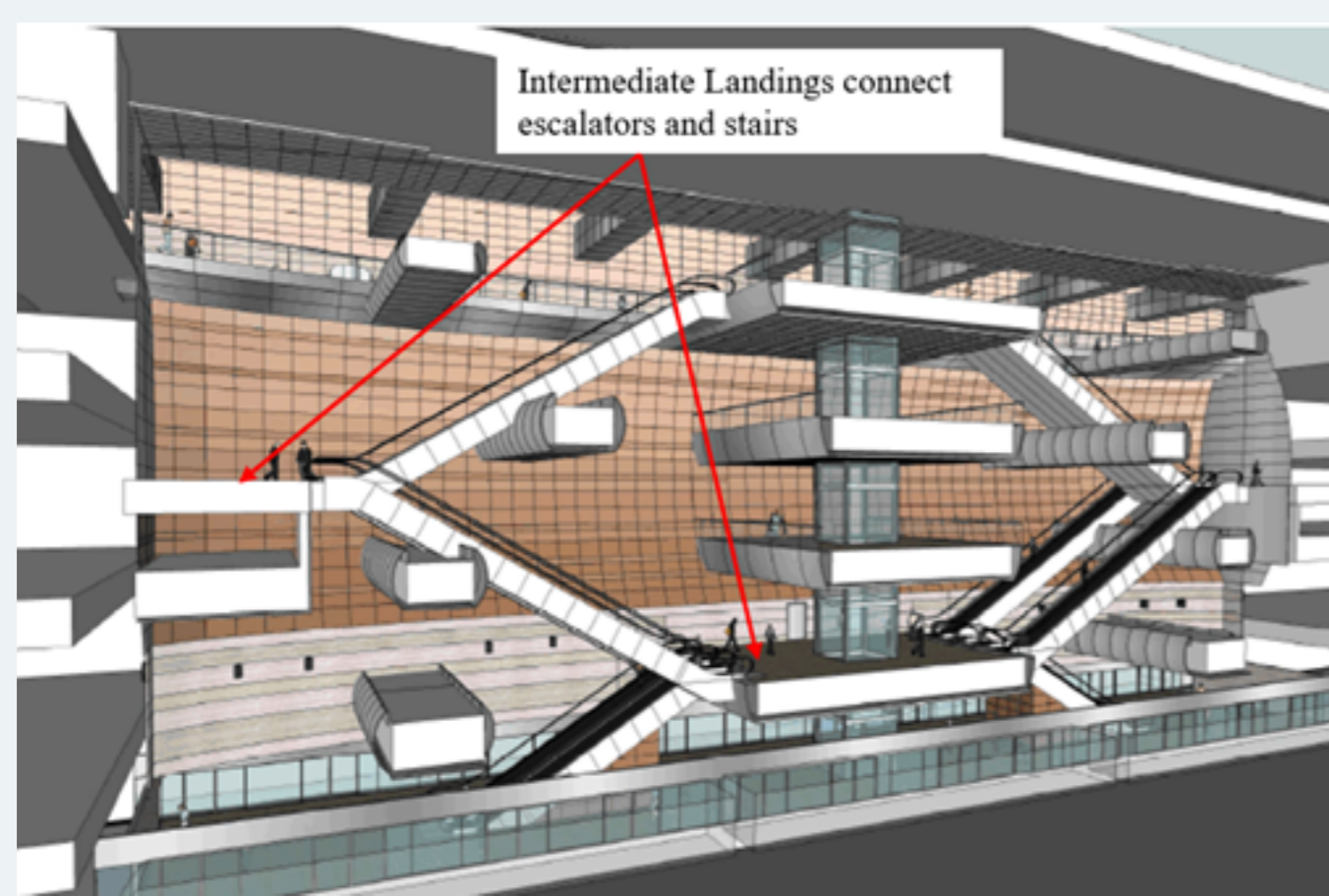

TABLE 2.2.3c.(2)(e): NUMBER OF FLAT STEP AT ESCALATOR LANDINGS

Rise	Number of Flat Steps
Up to 6m	Not less than 2
6 – 18m	Not less than 3
Over 18m	Not less than 4

- (f) Where operating in the direction of exit travel, escalators shall be permitted to be left in the operating mode during evacuation.
- (g) Where escalator can be operated in the direction opposite to exit travel, the escalator shall be provided with stopping devices:
 - (i) at the escalator; and
 - (ii) at the PSC and/ or the OCC, except that the escalator shall be fully visible at the remote-control location.

d. Platform evacuation

There shall be sufficient exit capacity to evacuate the platform occupant load from the station platform in 4 mins or less. See [Annex 2A](#).

e. Evacuation to safety

The station shall be designed to permit evacuation from the most remote point of the platform to any one of the following in 6 mins or less. See [Annex 2A](#).

- (1) A point of safety
- (2) For stations with separated concourse and platform levels
 - Beyond the fare gates (unpaid areas) at the concourse level which is provided with sufficient exit capacity to evacuate people to the external smoothly without any waiting time along the egress routes.
- (3) For stations with shared concourse and platform level
 - Beyond the entrances to subways from concourse unpaid area or the foot of the escalators/ staircases at the concourse level leading to the upper levels, with smoke barriers placed either at the entrances to subways or at the foots of the escalator stairs at the concourse level leading to upper levels, whichever is applicable.

Stations with interchange-link and stations connected to non-transit occupancies shall comply with the relevant requirements of [Chapter 9](#).

f. Fire safety engineering analysis

Rationale

This clause defines the point of safety as a compulsory criterion in any and all evacuations. The point of safety is a safe exterior space located at grade point beyond any enclosing structure or other areas that afford adequate protection for passengers.

In lieu of the above requirements stipulated in [Cl.2.2.3d.](#) and [Cl.2.2.3e.](#), the station can be designed to permit evacuation from the most remote point of the platform to a point of safety through a fire safety engineering analysis. The fire safety engineering analysis shall demonstrate that during station trainway fire scenario, tenable conditions can be achieved for the safe evacuation of all passengers, in accordance with [Annex ZA.](#)

g. Determination of exit capacity

Exit capacity shall be calculated in accordance with [Cl.2.2.3h.](#) on the basis of the clear width of means of escape. The clear width of means of escape shall be the minimum width required under [Cl.2.2.8](#) plus, any additional incremental width available.

h. Capacity of means of escape

The capacity of means of escape in person per metre per minute (p/m/min), passenger travel speeds in metres per minute (m/min) shall be as shown in [Table 2.2.3h.](#)

i. Capacity of fare collection gates and turnstiles

Except as required by [Cl.2.2.3j.](#), the capacity of fare collection gates and turnstiles shall be as shown in [Table 2.2.3i.](#)

Rationale

Engineering analysis conducted by fire safety engineers can be an alternative option to prescribed requirements. The analysis must conclude that the environment in the station must remain tenable for the duration of passenger evacuation.

TABLE 2.2.3i.: CAPACITY FOR FARE COLLECTION GATES & TURNSTILES

Type of fare collection equipment	Capacity
Gates < 850mm wide	50 p/min per gate
Gates >= 850mm wide	80 p/min per meter
Turnstiles	25 p/min per gate

j. Gate-type emergency exits

- (1) Gate-type emergency exits shall be provided for at least 50% of the required means of escape capacity if turnstile-type fare collection gates are used.
- (2) Where gate-type emergency exits are provided they shall be electrically operated and deactivated in accordance with [Cl.2.2.18.](#)

Rationale

Gate-type emergency exits shall be provided for at least 50% of the required means of escape capacity at the fare control line because there is possibility that turnstile may malfunction due to mechanical failure, unlike the gate-type exits.

2.2.4 Means of escape from commercial spaces and ancillary areas

a. Number of exit staircases or exits

- (1) There shall be at least two independent exit staircases or other exits from every storey or part thereof, and the exit staircases or other exits shall be remotely located in accordance with [Cl.2.2.19.](#)
- (2) Where a room or space is required to be provided with two exits, each exit shall be of sufficient width to accommodate at least one-half the total occupant load.

Exception:

- (a) The requirement for two independent exit staircases or other exits is exempted under [Cl.2.2.4b.](#), [Cl.2.2.4d.](#), [Cl.2.2.4e.](#), and [Cl.2.2.20.](#)

b. Single means of escape

Storeys or parts thereof, with rooms that are not high hazard occupancies shall be permitted to have a single means of escape where the maximum travel distance, inclusive of vertical distance complies with [Cl.2.2.4g.](#)

Rationale

The single means of exit is deemed adequate as the room it serves is of low fire-hazard.

c. Direct access

Every occupant shall have direct access to the required exit or exits without the need to pass through the spaces or rooms occupied by other occupants, plenums, or horizontal ventilation shafts.

Rationale

This is to ensure that all occupants will have full access to exits since rooms occupied by other tenants may deny them access in the event where the rooms in question are locked.

d. Buffer areas

For rooms located at the buffer areas, the maximum one-way and two-way travel distance shall not exceed 15m and 60m respectively. The determination of travel distance shall be in accordance with [Cl.2.2.4h.](#) Also, in addition to [Cl.2.2.4h.\(1\)](#), it shall also include a door opening directly to the non-incident trainway. See [Diagram 2.2.4d.](#)

e. Cable chamber and under-platform services ducts

For cable chamber or under-platform services ducts with headroom less than 2m:

- (1) Fixed ladders complying with [Cl.2.2.21](#) shall be acceptable as a means of escape.
- (2) Access to fixed ladder at platform level shall not impede the direct path of egress.
- (3) Under-platform services ducts shall be provided with at least two means of escape with exits or exit accesses located near the two ends of the under-platform services ducts. Travel distances in [Cl.2.2.4d.](#) and [Cl.2.2.4g.](#) are not applicable to under-platform services ducts, except that one-way travel to exit or exit access shall not exceed 15m. It is acceptable that exit accesses are provided in the fire-rated wall that separates the under-platform services ducts into two sections as required by Note 8 of [Table 6.4A.](#)

f. Capacity of exit facilities

The capacity of exits, exit staircases, exit passageways, corridors, exit doors, and other exit facilities shall be measured in units of width of 500mm. The number of persons per unit of width shall be as shown in [Table 2.2.4f.](#)

Rationale

As cable chambers and service ducts are only access by maintenance personnel and not regarded as separate storeys in transit stations, such spaces can be provided with cat-ladder in lieu of staircases for evacuation during an emergency.

g. Maximum travel distance

The maximum travel distance measured in accordance with [Cl.2.2.4h.](#) shall not exceed the value as shown in [Table 2.2.4g.](#)

Rationale

The time required by occupants to reach an exit during a fire emergency is critical. Maximum permissible travel distance to exits take into consideration that commuters are alert and not likely to be trapped in smoke logged spaces. In general, a minimum of two exits, located remote from each other, shall be required.

Explanation and Illustrations

Open-to-sky occupancy is relatively safe as there is likely no concern of smoke-logged. As such the maximum travel distance adopt sprinkler-protected category.

h. Determination of travel distance

Determination of travel distance shall be as follows:

- (1) The travel distance shall be the distance measured from the most remote point in the floor area to a door opening directly to
 - (a) an exit staircase, or
 - (b) an exit passageway, or
 - (c) an area of refuge, or
 - (d) the station public area, or

Explanation and Illustrations

The requirement of travel distances is not applicable to both air shafts and plenums provided the air shafts and plenums are:

- a. of non-combustible construction, and
- b. contain only equipment and services serving the air shafts/ plenums and services as shown in [Table 7.1.16](#)

- (e) an open exterior space.

- (2) The most remote point from which the travel distance is measured shall be taken as being 400mm from the enclosure walls of the floor area.

- (3) Where permitted under [Cl.2.2.10a.\(2\)](#) for exit staircases to be entered without the provision of an exit door, the travel distance shall be measured to a position where the exit door would be installed if otherwise required.

Explanation and Illustrations

Open-to-sky occupancy is relatively safe as there is likely no concern of smoke-logged. As such the maximum travel distance adopt sprinkler-protected category.

2.2.5 Smoke-free approach to exit staircase of elevated stations

Rationale

The smoke-free approach is intended to act as a buffer space for entry into the exit staircase by evacuees and used by firefighters during a fire emergency.

Entry at every storey level (including 1st storey) to an exit staircase of any station or part of a station of more than four storeys above ground level shall be through any one of the following:

a. External exit passageway or external corridor

The openings for natural lighting and ventilation to the corridor shall be located such that they face and are open to any of the following:

- (1) an external space, or
- (2) a street, service road, or other public space, which is open to the sky, or
- (3) an air well which opens vertically to the sky and has a minimum width of 6m and a superficial plan area of not less than 93m².

b. Smoke-free lobby

- (1) A smoke-free lobby shall be separated from the adjoining areas of the station by a wall having 1-hr fire resistance.
- (2) The exit access door shall have ½-hr fire resistance fitted with automatic self-closing device conforming to the requirements of [Cl.3.9.2](#).
- (3) The design of a smoke-free lobby shall be such as not to impede movement of occupants through the escape route.
- (4) The floor area of a smoke-free lobby shall be at least 3m² and with minimum clear width of 1.2m. If a smoke-free lobby also serves as a fire lift lobby or serve the firefighting staircase, the floor area shall be not smaller than 6m² and with minimum clear width of 2m.
- (5) The floor shall be graded from the lift door towards the lobby door with a fall not exceeding 1 in 200.
- (6) A smoke-free lobby, including fire lift lobby, which acts as buffer space for entry into the protected staircase and use by firefighters during emergency, shall be maintained as common property.
- (7) A smoke-free lobby shall be ventilated through any of the following:
 - (a) Permanent fixed ventilation openings which are located in the external wall of the lobby and have a total area of not less than 15% of the floor area of the lobby.
Each opening shall not be less than 1m² and shall abut an external space or air well, having a minimum clear area of 93m² and minimum width of 6m and without obstruction vertically throughout the airspace for ventilation. No part of the lobby floor area shall be more than 9m away from the air well or external space.
 - (b) Mechanical ventilation, which complies with the requirements in [Chapter 7](#).
 - (c) Cross-ventilated corridor/ lobby which complies with all the following:
 - (i) The corridor/ lobby shall have fixed ventilation openings abutting an external space. The ventilation openings shall be located on opposite sides of the corridor/ lobby at high level and shall not be less than 50% of the superficial area of the opposing external walls.
 - (ii) No part of the floor area of the corridor/ lobby shall be at a distance of more than 12m from the ventilation openings.
 - (iii) The distance of 12m can be measured along the internal corridor via the intermediate ventilation opening to the external space, provided there is no unprotected openings in the walls along the path to the external space. The intermediate ventilation opening shall not be less than 2m in width and 1.2m in height and the width of the path to the external space shall not be less than 2m.

Rationale

Smoke-free lobby shall be either naturally or mechanically ventilated to ensure smoke-free in order to provide a reliable means of escape for passenger and access for firefighters.

2.2.6 Smoke-free approach in basement

Rationale

Access to exits must be free of smoke and be available to building occupants at all times. Therefore, a reliable means of escape for commuters and access for firefighters shall be provided via smoke-free access route and staircases. For that reason, providing positive pressure by mechanical ventilation systems to smoke-free lobbies and exit staircases will prevent smoke infiltration. Fire lift lobby can be used by firefighters for rescue and firefighting operations and by passengers with limited mobility such as the elderly or persons with disabilities for emergency escape or transport to a refuge area.

- a. In a station comprising more than four basement storeys, entry to exit staircase serving the basement storeys at every basement storey level shall be through smoke-free lobbies;
- b. Entry to exit staircase and firefighting staircase at every basement storey level shall be via smoke-free lobby or fire lift lobby in accordance with [Cl.4.2.3](#); and
- c. Smoke-free lobby and fire lift lobby shall be required to comply with the relevant provisions under [Cl.2.2.5b](#) and [Cl.4.2.3c](#), respectively. They shall be mechanically ventilated to comply with the requirements in [Chapter 7](#).

2.2.7 Area of refuge and exit reduction

When a floor area has access to area of refuge in compliance with all the requirements in this Clause, the occupant load of the vertical exits can be reduced to ½ when one area of refuge is provided and to ⅓ when two or more areas of refuge are provided.

- a. An area of refuge shall be adequate in size to hold the occupant load it receives from the floor area which it serves as provision for required exit. This is in addition to its own occupant load calculated on the basis of 0.3m² per person.
- b. An area of refuge shall be entered through an external corridor and the room, space, or area of refuge shall be separated from the corridor by a wall with at least 1-hr fire resistance.
- c. External corridors when used as entry into an area of refuge shall conform to the requirements of external exit passageway for minimum width, changes in floor level, roof protection, enclosure on the open side and provision of opening of wall between the room or space and the exit passageway.
- d. Exit doors between the room, space, or area of refuge and the external corridor shall have fire resistance of at least ½ hr and fitted with automatic self-closing device to comply with the requirements of [Cl.3.9.2](#).
- e. Every fire compartment in which exit reduction is permitted in connection with area of refuge shall have, in addition, at least one staircase complying with [Cl.2.2.10](#) to exit through the area(s) of refuge.

2.2.8 Minimum width

The minimum clear width of means of escape shall be as follows:

- a. 2.3m for platforms measured from the platform screen door to any obstruction;
- b. 2.5m for platforms measured from the platform edge to any obstruction;
- c. 1.75m for public corridors and ramps;
- d. 1m for non-public corridors and ramps;
- e. 1m for stairs and exit passageways;
- f. 500mm for fare collection gates;
- g. 460mm for turnstiles;
- h. 850mm for doors and gates; and
- i. 500mm for under-platform services ducts.

2.2.9 Dead-end

The maximum length of dead-end shall not exceed 15m (non-sprinkler-protected) or 20m (sprinkler-protected).

2.2.10 Exit staircase

- a. Internal exit staircase
 - (1) Except as permitted in [Cl.2.2.3c](#), an internal exit staircase which serves as the required exit of the station shall be enclosed with construction complying with the provisions of [Cl.3.8](#). The enclosure walls of an internal exit staircase shall not have more than two exit doors opening into the exit staircase shaft at each storey. The two doors shall exclude the final discharge door;
 - (2) Where an internal exit staircase is directly approached from an external exit passageway or external corridor, it is not necessary to provide such enclosure between the staircase and the external exit passageway or external corridor provided no unprotected openings are located within 3m from the exit staircase; and
 - (3) There shall be no unprotected openings of occupancy area or combustible material/ construction within 1.5m horizontally or within 3m vertically below any opening including final discharge openings located in the external walls of the internal exit staircase.
- b. External exit staircase
 - (1) External exit staircase can be used as a required exit in lieu of internal exit staircase provided it complies with the requirements of exit staircase, except for enclosure of an internal staircase; and
 - (2) There shall be no unprotected openings within 3m horizontally or within 3m vertically below any part of the external exit staircase.
- c. Discharge

All exit staircases shall discharge at ground level directly into:

 - (1) an external space, or
 - (2) an open-sided external corridor with no commercial activity and is not more than 5m from the station eave line, or
 - (3) an open-to-sky corridor having minimum width of 1.2m and two-way escape paths leading to an external space. Any unprotected openings along the corridor shall not be located lower than 1.8m from the floor level, or
 - (4) In a sprinkler-protected station, a maximum of 50% of the total number of exit staircase can be discharged directly to the ground level covered circulation space provided all the following are complied with:
 - (a) The discharge point of the exit staircase into the ground level circulation space shall be within sight of and with direct access to an external space.
 - (b) The maximum distance between the discharge point of an exit staircase and the external space shall not exceed 10m.
 - (c) Where there are commercial activities e.g. shops or kiosks/ carts located along one side or both sides of the designated escape passageway leading to an external space, a minimum separation distance of 10m shall be maintained between the commercial activities and the designated escape passageway. The circulation space shall also be installed with engineered smoke control system. Alternatively, the commercial activities shall be fire compartmented with walls and doors of minimum 1-hr fire resistance rating.
 - (d) The clear width of the exit doors leading to an external space shall be adequate to receive the occupant load in the 1st storey circulation space and the total number of people discharging from the internal exit staircases.
- d. The minimum width and capacity of exit staircases shall be in accordance with [Cl.2.2.3h](#), [Cl.2.2.4f](#), and [Cl.2.2.8](#).
- e. No part along the direction of escape shall be less than the minimum required width for the stairs and landings.

Rationale

The separation distance from nearby openings is required to prevent ingress of smoke and fire spread from nearby unprotected openings.

f. Handrails

- (1) Every exit staircase shall have handrails on both sides. For exit staircases with only 1.25m or less in width, handrail can be provided at one side i.e., the opposite side shall be either wall, parapet, or grilles;
Exception: Handrails are not required for any staircase having not more than five risers.
- (2) Where staircases exceed 2m in width, handrails shall be used to divide the staircase into sections between 1m to 2m of width;
- (3) Handrail ends shall be returned to the wall or floor or shall terminate at newel posts; and
- (4) Handrails that are not continuous between flights shall extend horizontally, at the required height, at least 300mm beyond the top riser and continue to slope for a depth of one tread beyond the bottom riser.

g. Use of exit enclosure

Where fire-separated exit staircases are provided,

- (1) there shall be no enclosed useable space within the exit enclosure, including under stairs; and
- (2) the exit enclosure shall not be used for any purpose that has the potential to interfere with egress.

Rationale

Rooms should not be enclosed within exit staircase areas as they may act as fire hazards i.e. such rooms may be furnished with furniture, equipment, space dividers and the like.

h. Stair identification sign

Staircases shall be provided with a sign with dimensions of at least 300mm x 300mm within the stairwell at each storey landing. The sign as seen in [Diagram 2.2.10h](#). shall contain the following information in the order as follows:

- (1) The storey number, at least 125mm in height;
- (2) An identification of the staircase in alphabet and/ or number, at least 25mm in height;
- (3) The sign shall be located such that it is visible when the door is in the open position and also visible to any person moving up or down the staircase; and
- (4) The letters and numbers on the sign can be of any colour that shall contrast with the background colour.

Rationale

Such sign facilitates passengers and firefighters in knowing which floor they are at within the enclosed stairway.

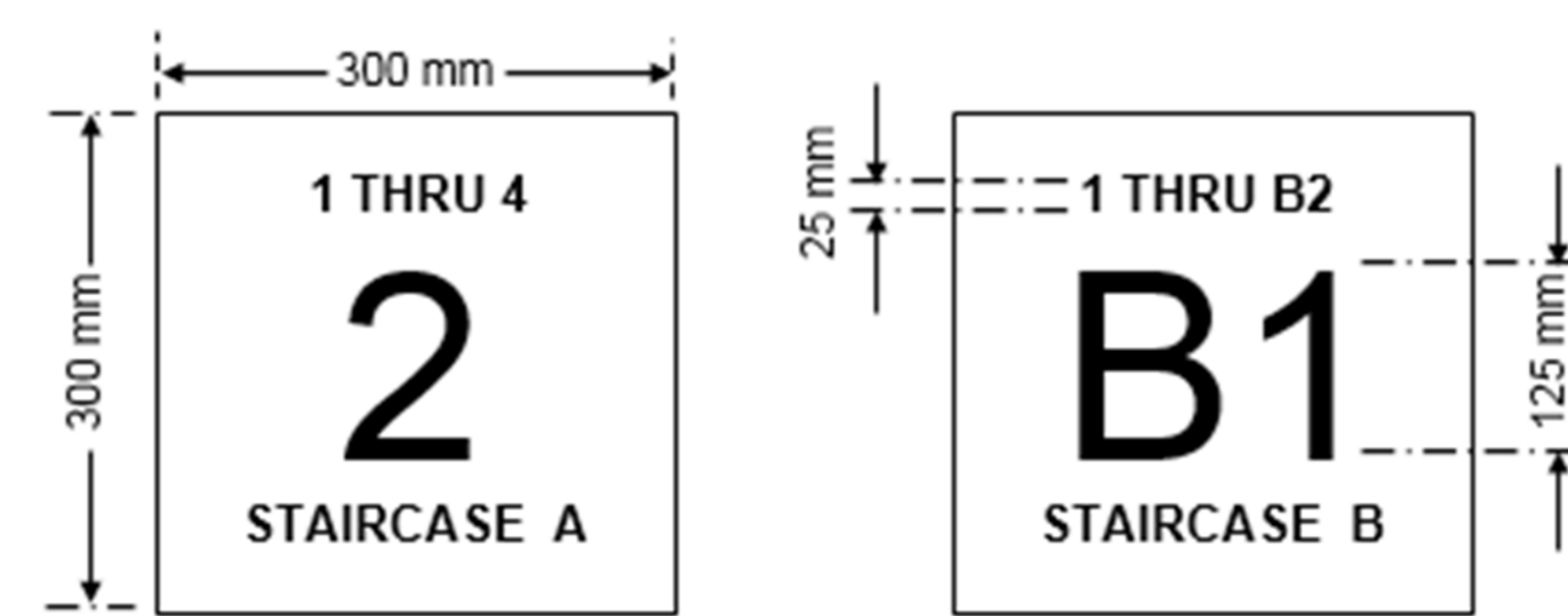

Diagram 2.2.10h: Stair Identification Sign

i. Ventilation

All exit staircases shall be ventilated by fixed openings in the external walls. Such openings shall be of area at least 10% of the floor area per floor of the staircase, or mechanically ventilated to comply with the requirements in [Chapter 7](#). Exit staircase and occupancy area shall not share the same air well or void for lighting and ventilation.

j. Pressurisation

In any station of which the habitable height exceeds 24m, any internal exit staircases without provision for natural ventilation shall be pressurised to comply with the requirements in [Chapter 7](#). In a station comprising more than four basement storeys, the exit staircase connecting to the fire lift lobby shall be pressurised.

k. Landings

The minimum clear width and length of a landing where there is a change in direction shall not be less than the clear width of the exit staircase.

l. Risers and treads

The height of riser for any exit staircase shall not be more than 175mm and depth of tread shall not be less than 275mm.

m. Headroom

The clear headroom shall be at least 2m measured from the pitch line of the exit staircase or finished floor level of the landing to the underside of any obstruction

n. Measurement of width

The clear width shall be measured between:

- (1) the finished surfaces of the walls, if the staircase is enclosed on both sides by walls only, or
- (2) the finished surface of the wall and the inner side of the balustrade, if the staircase has a wall on one side and a balustrade on the other side, or
- (3) the inner sides of the balustrades if the staircase has balustrades on both sides.

Note: The projection of handrail into the clear width of a staircase shall not exceed 80mm on each side of the staircase. If the projection exceeds 80mm, the clear width of the staircase shall be measured from the inner sides of the handrails.

Explanation and Illustrations



Staircases and escalators are provided in station to facilitate evacuation and operation needs. Where clear width of staircases exceed 2m in width, it can qualify as exit capacity for determination of a staircase. The requirement of handrail for the escape staircases shall be in accordance with *Cl.2.2.3c.(1)* & *Cl.2.2.10f*.

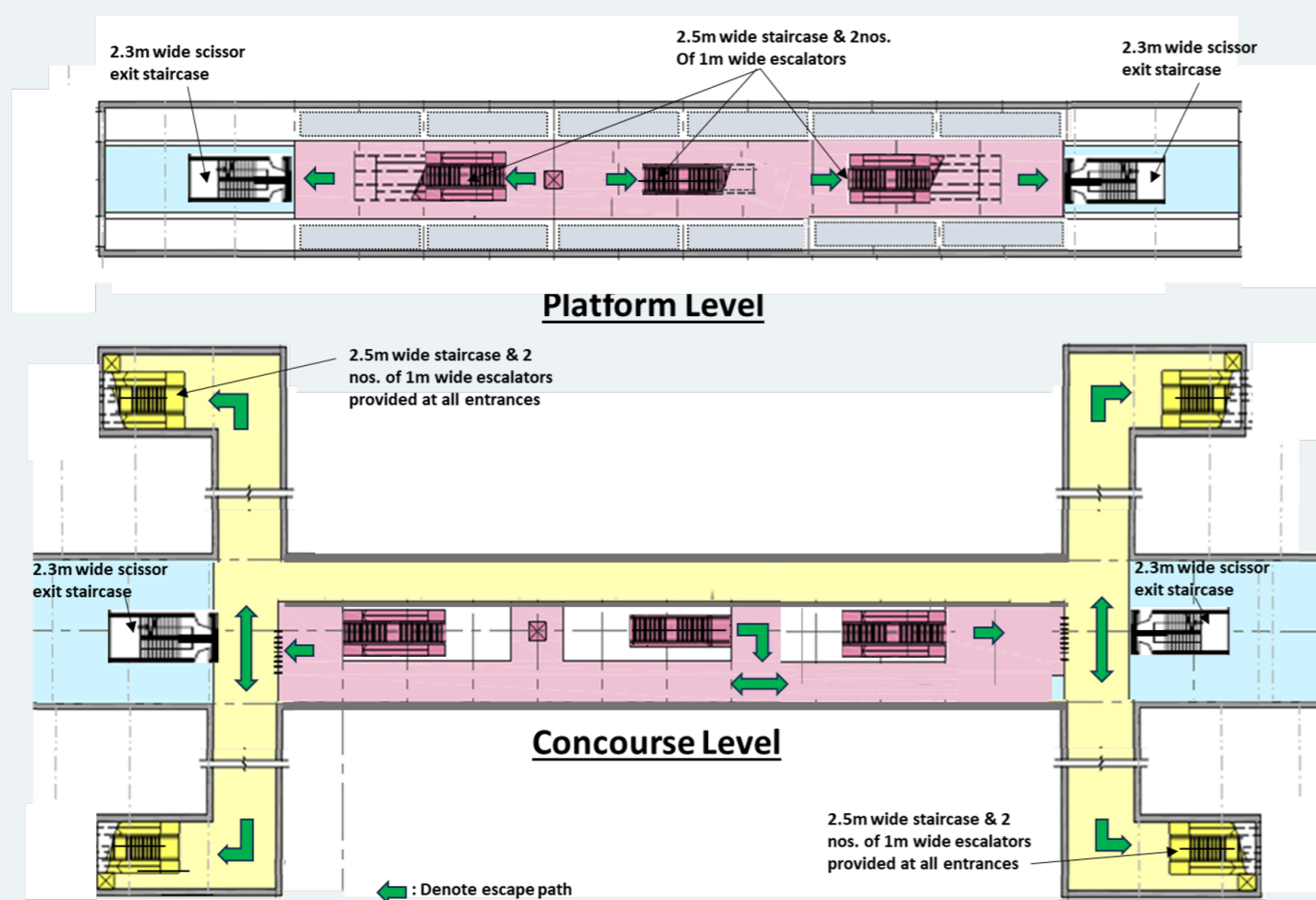

Station platform public area shall be served by at least two means of escape and remote from each other. Sufficient exit capacity shall be provided to clear the platform occupant load by 4 minutes and evacuation from the most remote point of the platform to a point of safety or alternate safe location not longer than 6 minutes (i.e. *Cl.2.2.3a, d. & e.*). All escape distances and flow times of occupant load via all exit elements are computed/ considered in the exiting analysis as required under the code.

2.2.11 Fire escape plan

a. A fire escape plan shall be provided for all station platform and concourse public areas. They shall be located such that they are easily viewable by the occupants passing through these areas which shall include lift lobbies for lift between platform and concourse, ticketing areas at concourse level, smoke-free lobbies, firefighting lobbies and fire lift lobbies. The fire escape plan shall have legible lettering and the fire escape routes made clear to the viewer. It shall clearly show the layout of the floor in the correct orientation and highlight the escape routes (in relation to viewer's location), escape corridors, and exit staircases using appropriate colours, directional signs and words. The information required on the plan are for firefighting and evacuation purposes and shall include the locations of the following:

- (1) PWD lifts;
- (2) Hose reels;
- (3) Fire extinguishers;
- (4) Emergency fire phones;
- (5) Passenger Service Centre;
- (6) Fire lifts;
- (7) Manual alarm call points; and
- (8) Rising mains.

b. For ensuring legibility of the fire escape plan for stations with large floor areas, a partial plan of the location where the viewer is standing, showing the escape routes and firefighting provisions located within the area, is acceptable. The plan shall show the egress paths to at least 2 remotely located exits/ exit staircases.

2.2.12 Scissors exit staircase

a. Where two separate internal exit staircases are contained within the same enclosure, each exit staircase shall be separated from the other by non-combustible construction. They shall have fire resistance for a minimum period equal to that required for the enclosure; and

b. Such scissors exit staircases shall comply with all applicable provisions for exit staircase under *Cl.2.2.10*.

2.2.13 Basement exit staircase

a. Any exit staircase which serves a basement storey of a station shall comply with all the applicable provisions for exit staircase under *Cl.2.2.10*;

b. Such exit staircase shall not be made continuous with any other exit staircase which serves a non-basement storey of the station; and

c. Basement exit staircases which are vertically aligned with the exit staircases of non-basement storeys shall be separated from such other exit staircases by construction having fire resistance for a minimum period equal to that required for the enclosure.

2.2.14 Spiral staircase

Rationale

Spiral staircases are not suited as required exits because they are typically steep and winding, thus causing occupants to take a longer time to complete their descent. The varying thread size also leads to the increased risk of occupants slipping and losing their footing.

Spiral staircases shall not serve as required exits unless they comply with all the following conditions. They shall:

- a. be external and unenclosed;
- b. serve only mezzanine floors, balconies, or any storey of occupant load not exceeding 25 persons;

- c. be constructed of non-combustible materials;
- d. have a tread length of at least 750mm;
- e. be at most 10m high; and
- f. comply with the applicable requirements of [Cl.2.2.10](#).

2.2.15 Exit ramp

Rationale

Ramps are used at floor level transitions to prevent accidents where abrupt elevations may cause tripping.

- a. Internal and external exit ramps can be used as exits in lieu of internal and external exit staircases subject to compliance to [Cl.2.2.10](#);
- b. The minimum width and capacity of exit ramp shall be in accordance with [Cl.2.2.3h](#), [Cl.2.2.4f](#), and [Cl.2.2.8](#);
- c. The slope of such exit ramps shall not be steeper than 1 in 12;
- d. Exit ramps shall be straight with changes in direction being made at level platforms or landings only. However, exit ramps having a slope not greater than 1 in 12 at any place can be curved;
- e. Level platforms or landings shall be provided at each door opening into or from an exit ramp;
- f. Level platforms or landings shall be provided at the bottom, at intermediate levels where required and at the top of all exit ramps;
- g. The minimum width of a platform or landing and length shall be not less than the width of the ramp, except that on a straight-run ramp, the length of the level platform or landing need not be more than 1m;
- h. All exit ramps shall be provided with non-slip surface finishes; and
- i. Exit ramps serving as means of escape to only one basement storey need not be protected by enclosure walls.

2.2.16 Exit passageways

- a. Exit passageways that serve as a means of escape or required exits from any station or storey of a station shall have the requisite fire resistance as specified under [Cl.3.3](#).
- b. Internal exit passageway
 - (1) An internal exit passageway which serves as required exit of the station shall be enclosed with construction complying with the provisions of [Cl.3.3](#);
 - (2) The enclosure walls of an exit passageway shall not have more than two exit doors opening into the exit passageway. The two doors shall exclude the final discharge door and exit staircase door;
 - (3) Exit doors opening into an exit passageway shall have fire resistance rating as required for exit doors opening into exit staircases, fitted with automatic self-closing device, and complying with the requirements of [Cl.3.9.2](#) for fire resisting doors;
 - (4) The minimum width and capacity of exit passageway shall comply with the requirements as provided in [Cl.2.2.3h](#), [Cl.2.2.4f](#), and [Cl.2.2.8](#);
 - (5) Changes in level along an exit passageway requiring less than two risers shall be by a ramp complying with the provisions under [Cl.2.2.15](#); and
 - (6) If the exit staircase which connects to the internal exit passageway is pressurised, the internal exit passageway shall not be naturally ventilated but shall be mechanically ventilated, and it shall be pressurised to comply with the requirements in [Chapter 7](#).
- c. External exit passageway
 - (1) An external exit passageway can be used as a required exit in lieu of an internal exit passageway. This is provided the external wall between the exit passageway and the rest of the floor space can have ventilation openings of non-combustible construction. Such openings shall be fixed at or above a level 1.8m, measured from the finished floor level of the passageway to the sill level of the openings. Such ventilation openings shall be located at least 3m from any opening of an exit staircase;
 - (2) An external exit passageway may not be subjected to the limitations of a maximum of two exit doors opening into the exit passageway;
 - (3) An external exit passageway can be roofed over provided the depth of the roofed over portion shall not exceed 3m to avoid smoke logging;
 - (4) An external exit passageway can be enclosed on the open side by only a parapet wall or solid balustrade of not more than 1m in height; and
 - (5) Exit doors opening into an external exit passageway shall have fire resistance for at least ½ hr and fitted with automatic self-closing device.
- d. Ventilation

Rationale

An exit passageway provides the same level of protection from the effects of heat and smoke as an exit staircase, and lead to a point of safety. It is essentially an extension of the staircase. Exit passageway is required when the travel distance from the occupied space to the exit staircase exceeds the required travel distance.

- (1) Except as permitted by sub-clause (2), all internal exit passageways shall be naturally ventilated by fixed ventilation openings in an external wall, such ventilation openings being at least 15% the floor area of the exit passageway; and
- (2) internal exit passageways that cannot be naturally ventilated shall be mechanically ventilated to comply with the requirements in [Chapter 7](#).

Rationale

In a fire scenario, there is possibility that exit passageway can become smoke-filled and trap occupants. Therefore, it is essential that internal exit passageways are positively pressurised to prevent smoke infiltration into these spaces.

2.2.17 Exit doors and exit access doors

Exit doors and exit access doors shall comply with all the following:

- a. Exit/ exit access doors shall be capable of being opened manually;
- b. Exit/ exit access doors which are required to have fire resistance rating shall comply with the relevant provisions for fire resisting doors under [Cl.3.9.2](#) and
- c. Measurement of door width
 - (1) In the case of an exit/ exit access door having a single leaf door, the opening shall be measured between the edge of the door jamb and the surface of the door when opened at an angle of 90°. See [Diagram 2.2.17c.\(1\)](#).
 - (2) In the case of a 2-leaf exit/ exit access door fitted with an approved automatic flush bolt, the clear openings shall be measured between the surface of one leaf to the other door leaf when opened at an angle of 90°.
 - (3) If one of the door leaves is bolted to the door frame and/ or floor by a manually operated bolt, this door leaf shall not be considered for the purpose of determining the exit capacity of the door. The opening of the other door leaf shall have a clear width of not less than 850mm, measured between the edge of the bolted door leaf and the surface of the other door leaf, when opened at an angle of 90°.
 - (4) Door hardware and handrails which do not protrude more than 80mm into the clear width of exit opening can be disregarded.
- d. Exit doors and exit access doors shall open in the direction of exit travel:
 - (1) when used in an exit or protected enclosure, or
 - (2) when serving a high hazard area, or
 - (3) when serving a room or space with more than 50 persons.
- e. Exit doors opening into exit staircases and exit passageways
 - (1) The doors shall not impede the egress of occupants when swung open in accordance with [Diagram 2.2.17e.\(1\)](#); and
 - (2) The corridor's clear width shall remain to be at least half of the required clear width as stipulated in [Cl.2.2.8](#) when such door(s) is swung open.

Exception: Exit access doors of plant rooms in buffer areas.

f. The maximum exit doors and exit access doors opening force shall be 30N at 0° and 20N at 30° opening.

g. Vision panel

The fire door to a protected staircase and smoke-free/ fire lift lobby shall be constructed to incorporate a vision panel. The vision panel shall have a clear view size of 100mm width by 600mm height. The vision panel shall have the requisite fire resistance rating and shall not turn opaque when subject to heat. The bottom edge of the vision panel shall be located at 900mm above the finished floor level.

Rationale

To enable firefighters to appreciate the situation before entering to the occupied space and prevent door opening into the staircase from accidentally hitting someone behind the fire door.

h. Revolving doors shall not be used as exit doors for required exits.

i. Where exit/ exit access doors in a means of escape are used in pairs,

(1) Approved automatic flush bolts shall be provided; and

(2) The unlatching of any leaf shall not require more than one operation.

j. Panic exit device

Latched exit doors in a means of escape from an area having an occupant load of 100 persons or more shall be equipped with approved panic exit device. The panic exit device shall operate to open the door when a pressure is applied on the bar in the direction of travel and be appropriately marked "Push Bar To Open" in letters not less than 50mm high.

k. Electrically operated doors in means of escape path

Where doors located in the required means of escape path are operated by power upon the approach of a person, the doors shall automatically open and remained at the fully open position,

(1) Upon activation of the station's fire alarm, or

(2) In the event of a loss of power to the door.

l. Access control using smart card locking device, electromagnetic/ electromechanical locking device

(1) The doors shall be unlocked in the event of a loss of power to the lock.

(2) Where access control using electromagnetic/ electromechanical locking device is installed on any exit access door and/ or exit door, such doors shall comply with the requirements stipulated in [Table 2.2.17l\(2\) - 1 & 2](#).

Rationale

Due to high possibility of jamming, revolving doors cannot be accepted as exit doors for escape purposes. When revolving doors are present, adjacent exit doors shall be provided and indicated clearly as such.

2.2.18 Fare collection gates and turnstiles

Rationale

Fare collection gates and turnstile shall be of sufficient width to be used as exits in the course of evacuation by passengers during an emergency.

a. Fare collection gates, when deactivated, shall provide a minimum clear width in accordance with [Cl.2.2.8f](#). Consoles shall not exceed 1.1m in height.

b. A turnstile-type fare collection gate shall provide a minimum clear width in accordance with [Cl.2.2.8g](#). Maximum height of the turnstile bar shall not exceed 1m.

c. Fare collection gates and turnstiles shall be designed to be deactivated automatically in the following events:

(1) A loss of power to the lock.

(2) Upon activation of a manually operated switch accessible to authorised personnel within the PSC, in the absence of which, at the OCC.

d. When deactivated:

(1) Freewheel or open in the exit direction; and

(2) Permit movement of passengers in the exit direction regardless of any failure to operate properly.

2.2.19 Two-way escape (Remoteness of exits)

Where more than one exit is required from an area, a room or a compartment, such exits shall be remotely located from each other and shall be arranged and constructed to minimise the possibility that more than one can be blocked by any one fire or other emergency condition. The following shall be complied with:

a. If two exits or exit access doors are required, they shall be placed at a distance from one another equal to or not less than half the length of the maximum overall diagonal dimension of the compartment or area to be served, measured in a straight line between the furthest edges of the exit doors or exit access doors. See [Diagram 2.2.19a - 1 to 6](#). If the distance between the two exits is less than half the length of the maximum overall diagonal dimension of the compartment or area to be served, it shall be considered as a one-way escape arrangement.

b. In rooms or compartments protected throughout by an approved automatic sprinkler system which complies with the requirements of [Chapter 6](#), the minimum separation distance between two exits or exit access doors measured in accordance with [Cl.2.2.19a](#) shall be not less than one-third the length of the maximum overall diagonal dimension of the compartment or area to be served.

c. Where exits are inter-connected by a corridor, exit separation shall be permitted to be measured along the line of travel within the exit access corridor. The exit access corridor connecting the exits shall be protected by at least 1-hr fire rated enclosures. Doors opening into this corridor shall have at least ½-hr fire resistance rating. See [Diagram 2.2.19c](#).

2.2.20 Non-habitable roof

Rationale

This clause addresses means of escape for non-habitable roofs.

For non-habitable roof described in [Cl.1.4.48](#), at least one exit staircase shall be provided. Where the area of non-habitable roof is large and one-way travel distance to the exit cannot be met, an additional fixed ladder in accordance with [Cl.2.2.21](#) and adequately separated in accordance with [Cl.2.2.19](#) and leading to the circulation area of the floor below shall be acceptable as a means of escape.

Exception:

(a) For green roofs which are accessible for maintenance purposes only, the means of access shall comply with [Cl.10.2.1b\(1\)\(a\)](#) of the Fire Code.

2.2.21 Fixed ladders

Rationale

This clause entails fixed ladder and access hatches requirements.

a. Fixed ladder shall comply with [ANSI A14.3](#), or [BS 5395: Part 3](#), shall be acceptable as a means of escape.

b. Any access hatches to access the fixed ladder, if provided, shall be readily openable and accessible from both above and below.

c. Access hatch openings shall have a minimum clear width of 1m.

d. The travel distance on the fixed ladder shall be measured as the vertical distance multiplied by a factor of 2.

CLAUSE 2.3 STATION WITH TWO OR MORE PLATFORMS STACKED ABOVE ONE ANOTHER

2.3.1 With reference to [Cl.2.2.2](#) where passengers are discharging from the incident platform via public area staircases and escalators onto the non-incident platform, the occupant load of the non-incident platform must include the passengers using public area staircases and escalators. Where passengers are discharging from the non-incident platform via public area staircases and escalators onto the incident platform, the occupant load of the incident platform must include the passengers using public area staircases and escalators.

2.3.2 Refer to [Diagram 2.3.2 – 1 & 2](#) for the occupant load calculations under the two scenarios for an underground station with two stacked platforms.

CLAUSE 2.4 STATION WITH PLATFORMS LOCATED SIDE BY SIDE SEPARATED BY TRAINWAY

2.4.1 Under each scenario, as defined under [Cl.2.2.2](#), the exit capacity for the incident platform shall cater for one train peak load for the largest available train serving that platform (the train load shall not be split between the two platforms).

2.4.2 Refer to [Diagram 2.4.2 – 1 & 2](#) for the occupant load calculations under two scenarios for an underground station with two platforms located side by side.

CLAUSE 2.5 SPECIAL REQUIREMENTS FOR PERSON WITH DISABILITIES (PWDS)

2.5.1 General

- a. The scope of these requirements on the design and management of transit stations covers the public areas and commercial spaces of transit stations and excludes RTS depots, ancillary buildings, viaducts, and tunnels. These requirements are intended for the safe evacuation of PWDS during fire emergency.
- b. Transit station public areas and commercial spaces are designed with barrier-free accessibility compliance, as required by the authority having jurisdiction on accessibility in the built environment. The ingress/ egress routes for PWDS shall also be used as evacuation routes for PWDS.
- c. Transit stations are of non-combustible construction. The station public areas and commercial spaces are segregated from the ancillary areas by fire-rated construction and are designed with emergency ventilation system to provide a tenable environment for evacuation in the event of fire emergency.
- d. Passenger lifts in stations are primarily provided for use by PWDS. These lifts that are located in the public area shall be used for the evacuation of PWDS.
- e. Management procedures and responsibilities shall be formulated for the evacuation of PWDS in the event of fire.
- f. The evacuation route for PWDS in the public areas and commercial spaces shall conform to the requirements stipulated in the 'Code on Accessibility in the Built Environment' shall be provided.
- g. The requirements in Section 2.5 do not apply to stations/ areas exempted from barrier-free accessibility compliance, as required by the authority having jurisdiction on accessibility in the built environment.

Diagram: 2.2.4d. island Platform

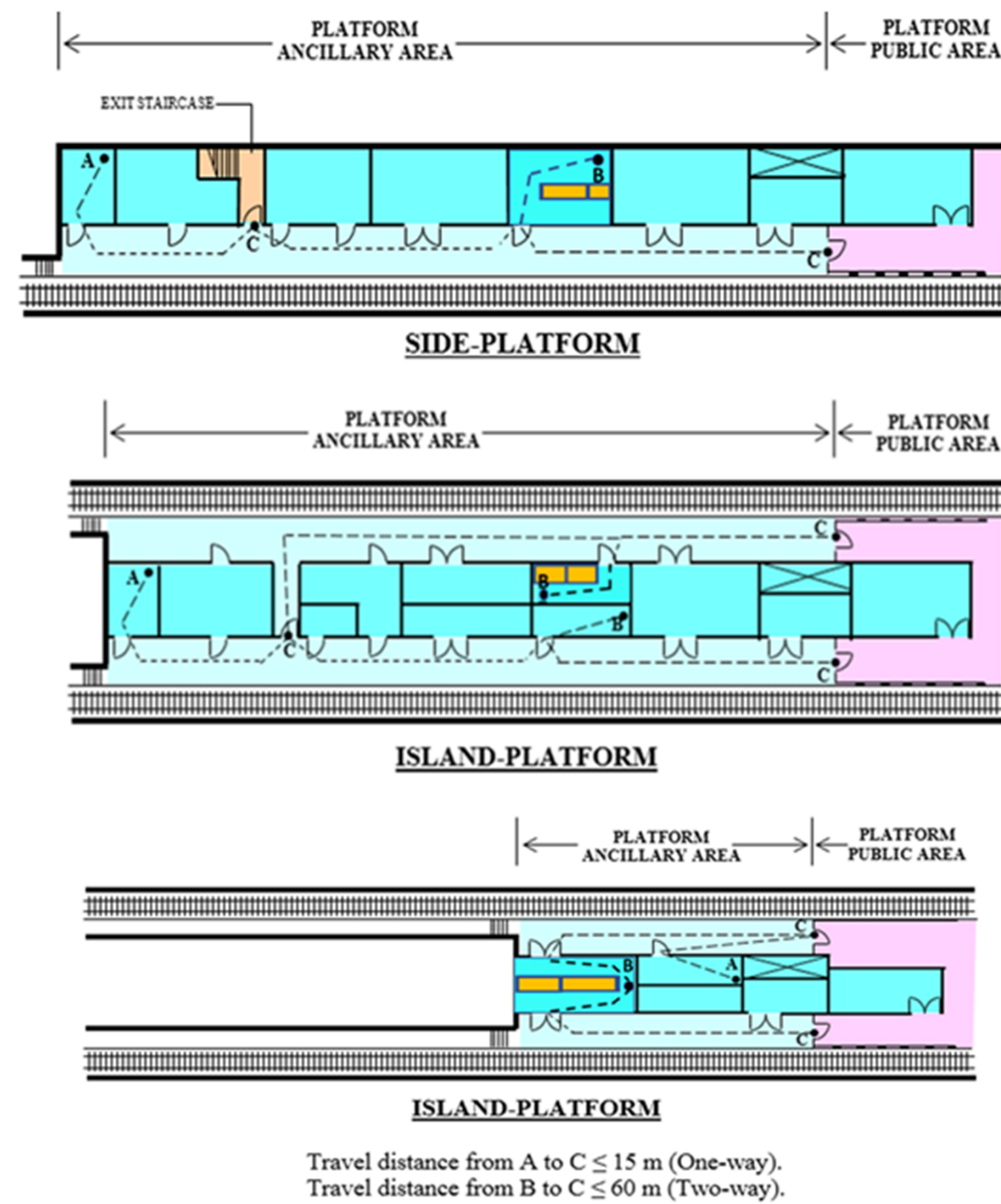
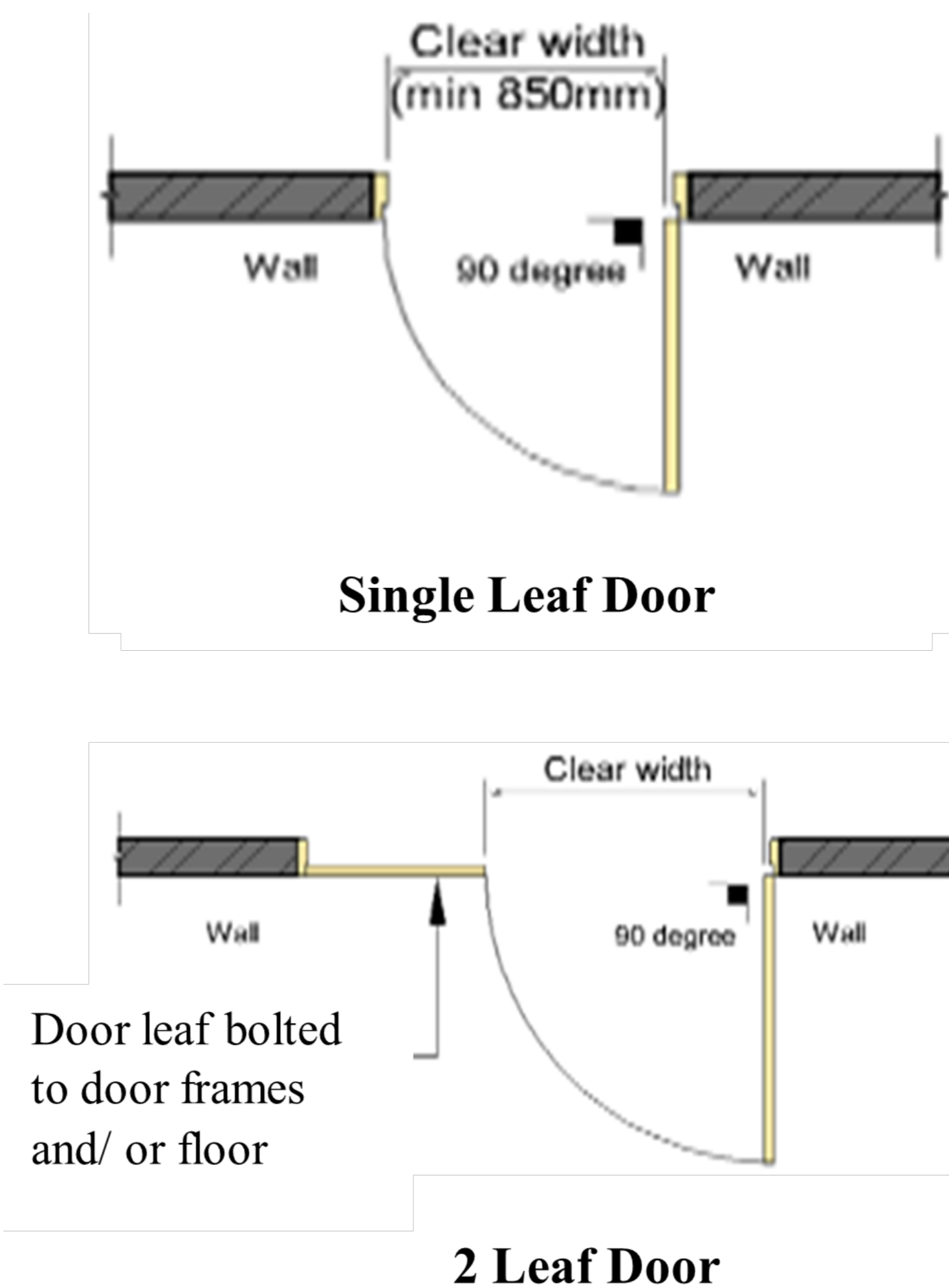
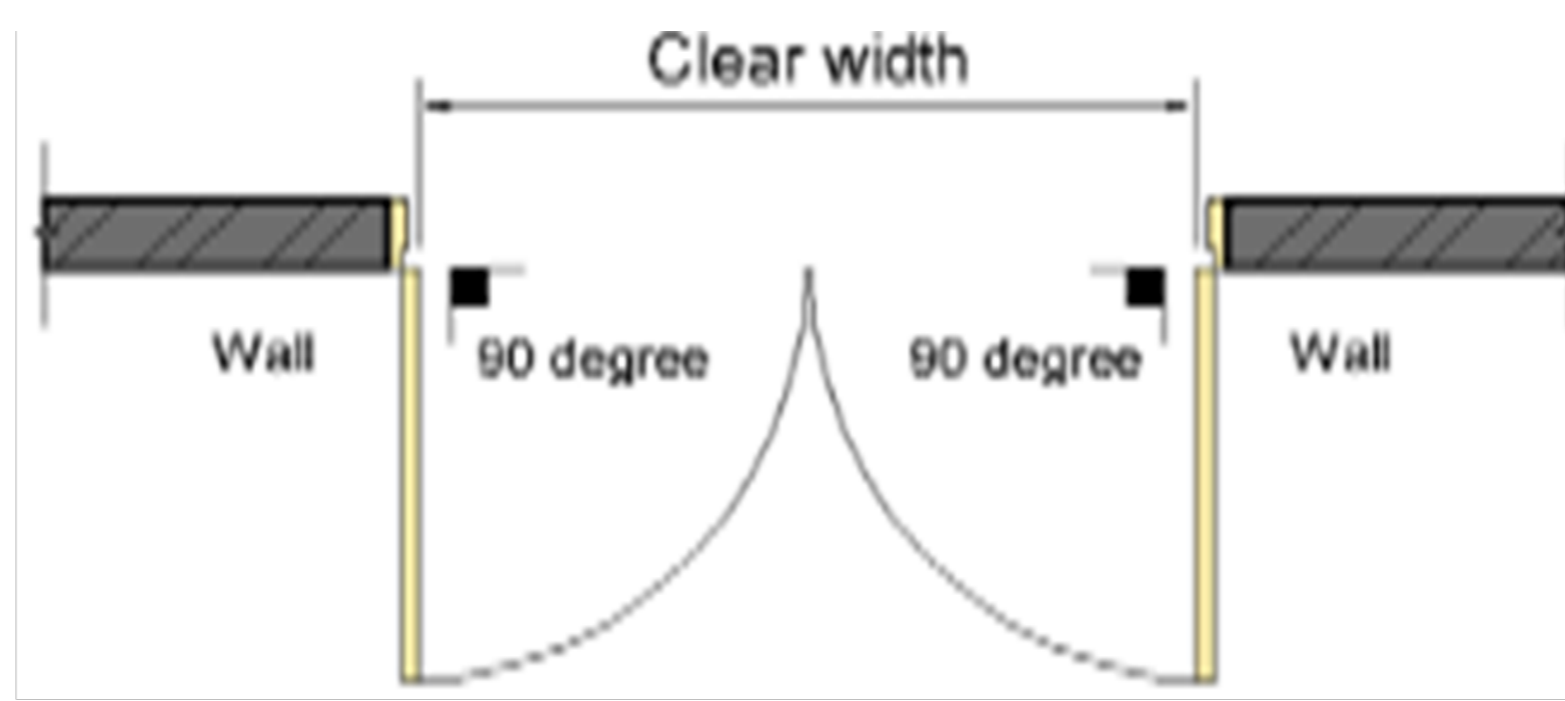

Diagram: 2.2.4d. island Platform

Diagram 2.2.17c.(1): Measurement of Door Width



For the fire doors, see hardware and other requirements for doors in [Cl.3.9.2](#)



2 Leaf Door

Sequential door closer shall be provided to both leaves.

Automatic flush bolt shall be provided. See [CI.2.2.17i.](#)

For fire doors, automatic self-closing devices on both door leaves and sequence selector shall be provided.

Diagram 2.2.17c.(1): Measurement of Door Width

Diagram 2.2.17e.(1): Exit Doors Opening into Exit Staircases and Exit Passageways

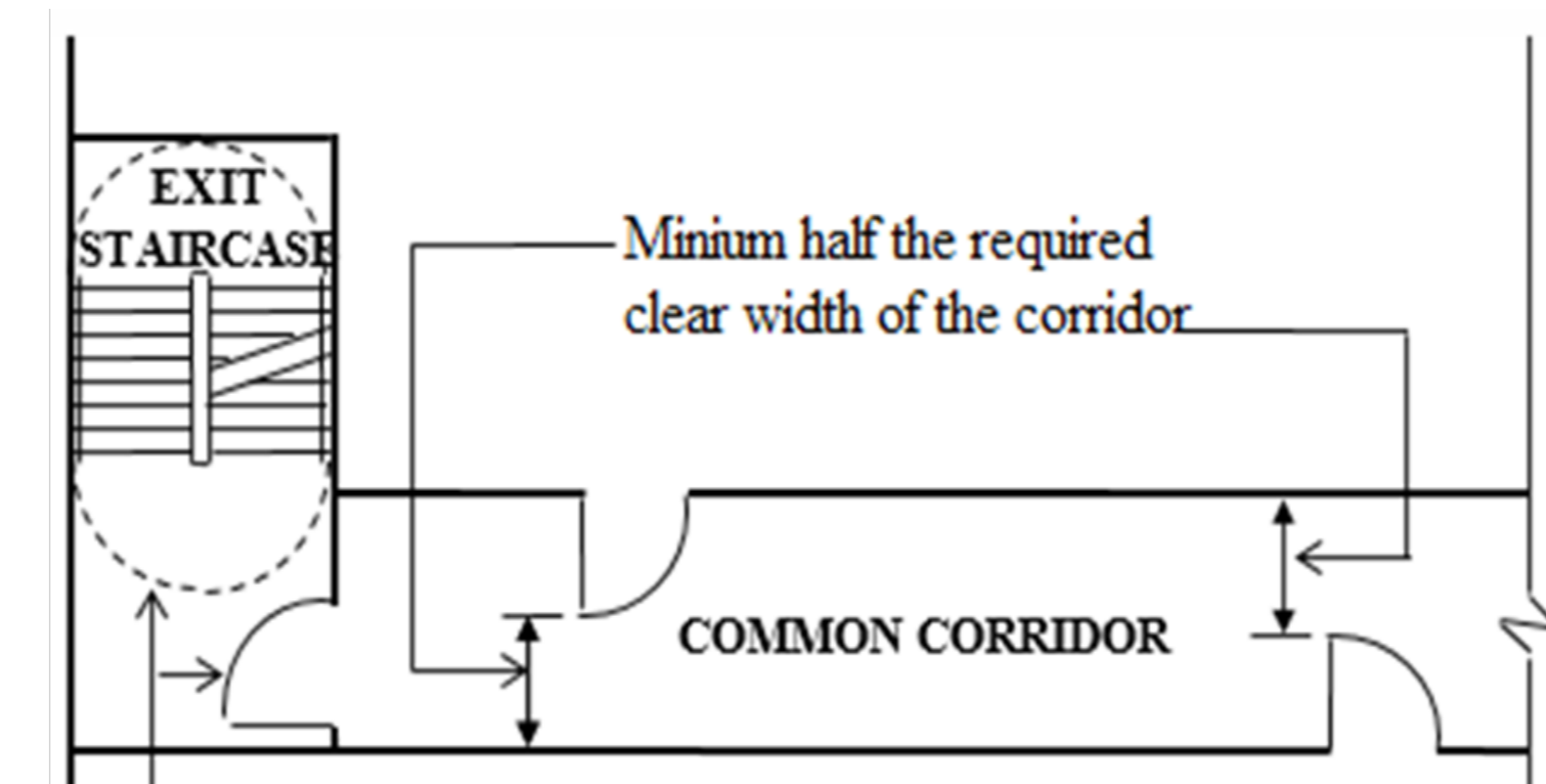

Door shall not encroach into the required width of the landing during its swing

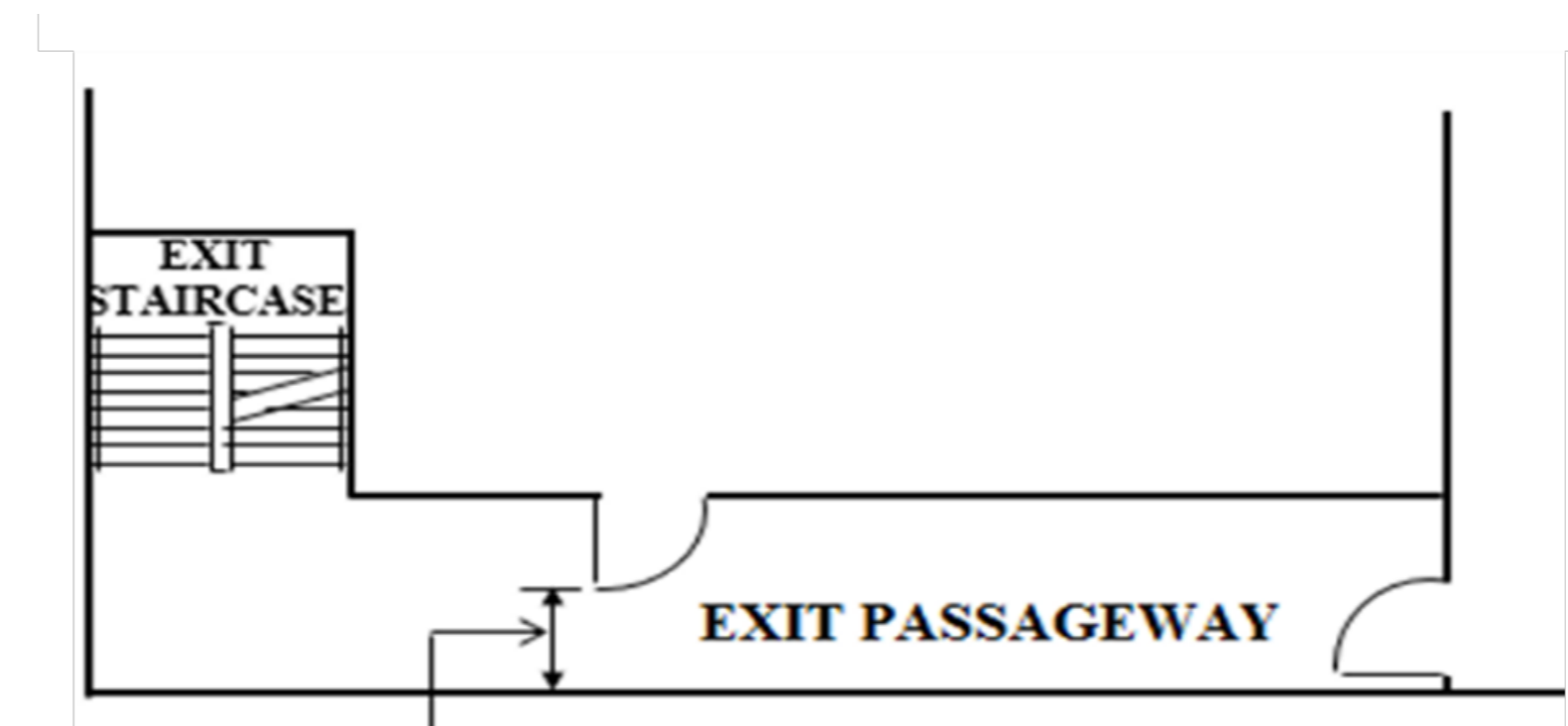

Minimum width of corridor as required under [CI.2.2.3h.](#), [CI.2.2.4f.](#), and [CI.2.2.8.](#);

Exit doors shall not impede the egress of occupants when such doors are swung open.

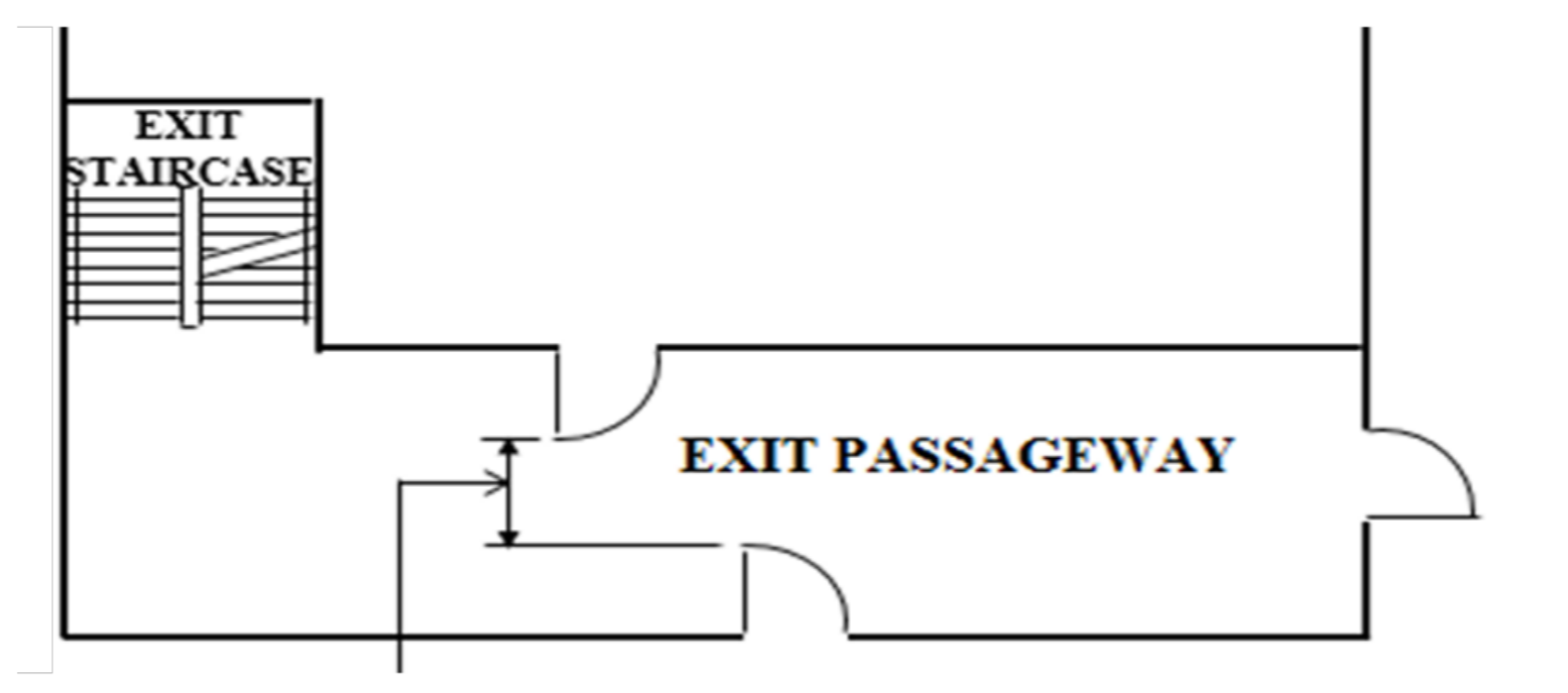

Minimum 1/2 width of corridor as required under [CI.2.2.3h.](#), [CI.2.2.4f.](#), and [CI.2.2.8.](#);

Diagram 2.2.17e.(1): Exit Doors Opening into Exit Staircases and Exit Passageways

Diagram 2.2.19a. - 1 to 6

Diagram 2.2.19a. - 1	Diagram 2.2.19a. - 2
<p>One-way escape arrangement The distance between the two staircases is less than half the length of the maximum overall diagonal dimension of the area</p> <p>Diagram 2.2.19a. - 3</p>	<p>Two-way escape arrangement The distance between the two staircases is less than half the length of the maximum overall diagonal dimension of the area</p> <p>Diagram 2.2.19a. - 4</p>
Diagram 2.2.19a. - 5	Diagram 2.2.19a. - 6

Diagram 2.2.19c.: Remoteness of Exit

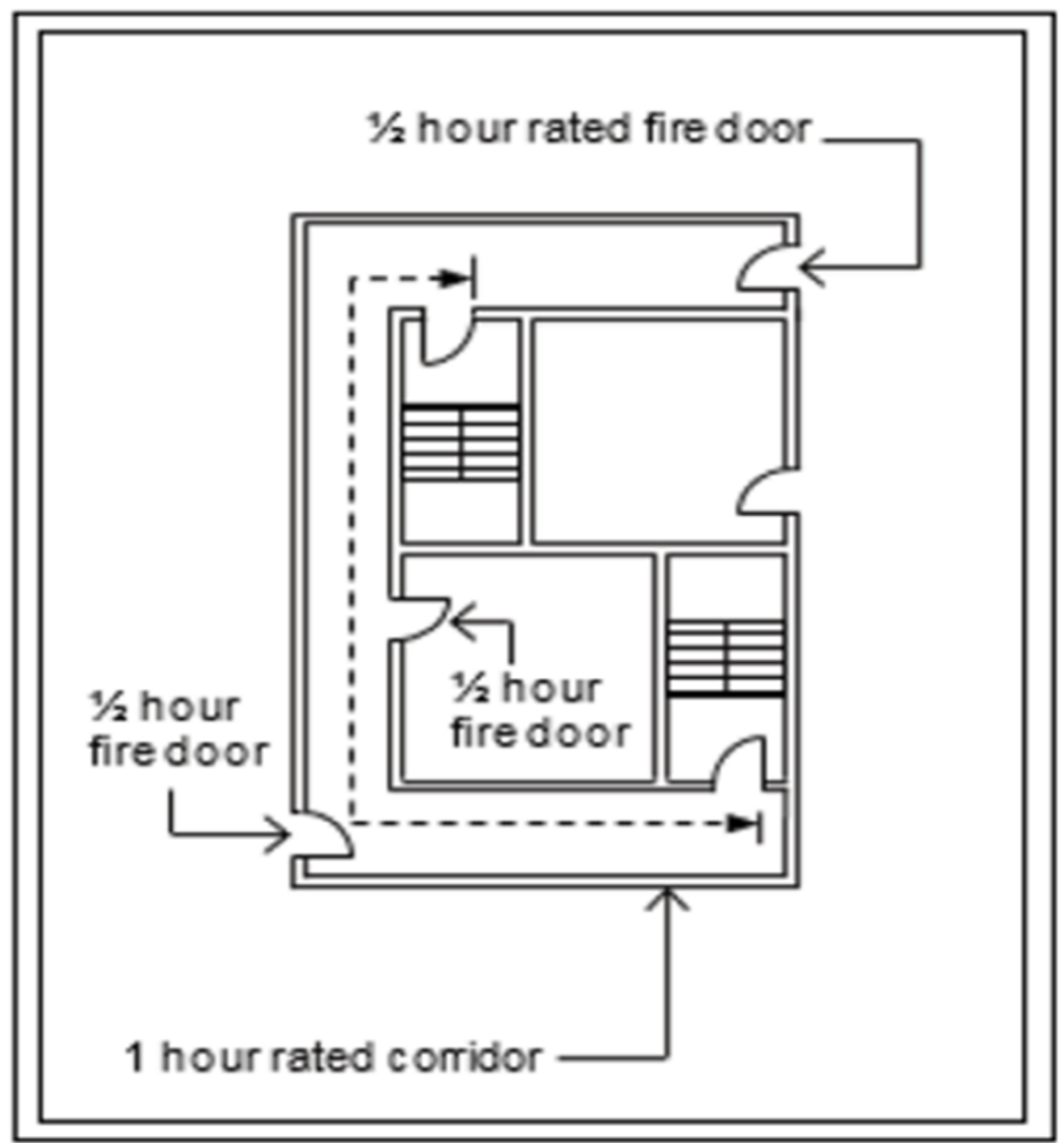

Remoteness of exits is measured along the 1-hr rated corridor with 1/2 hr fire doors

Diagram 2.2.19c.: Remoteness of Exit

Diagram 2.3.2 - 1 & 2

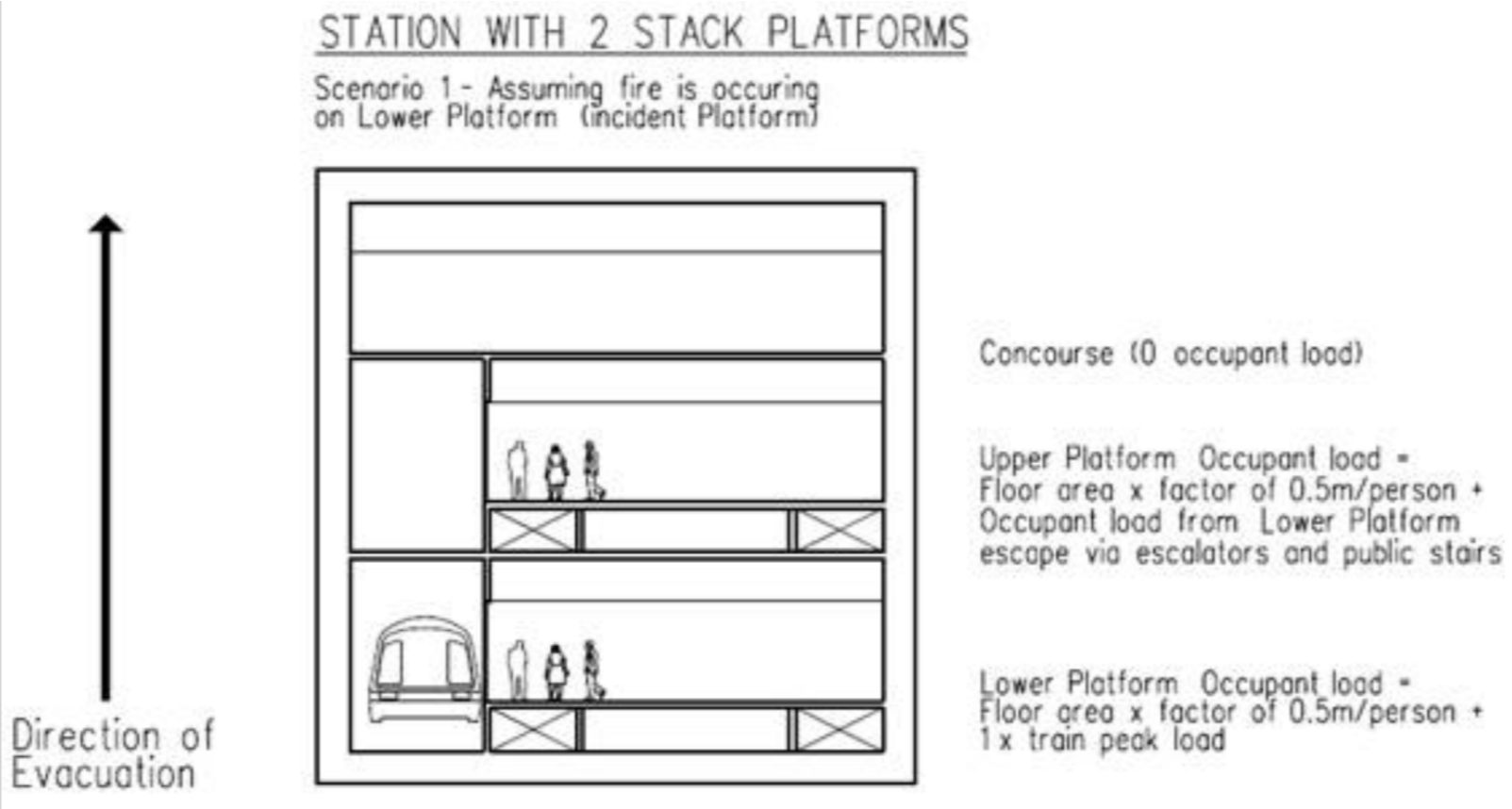

Diagram 2.3.2 - 1

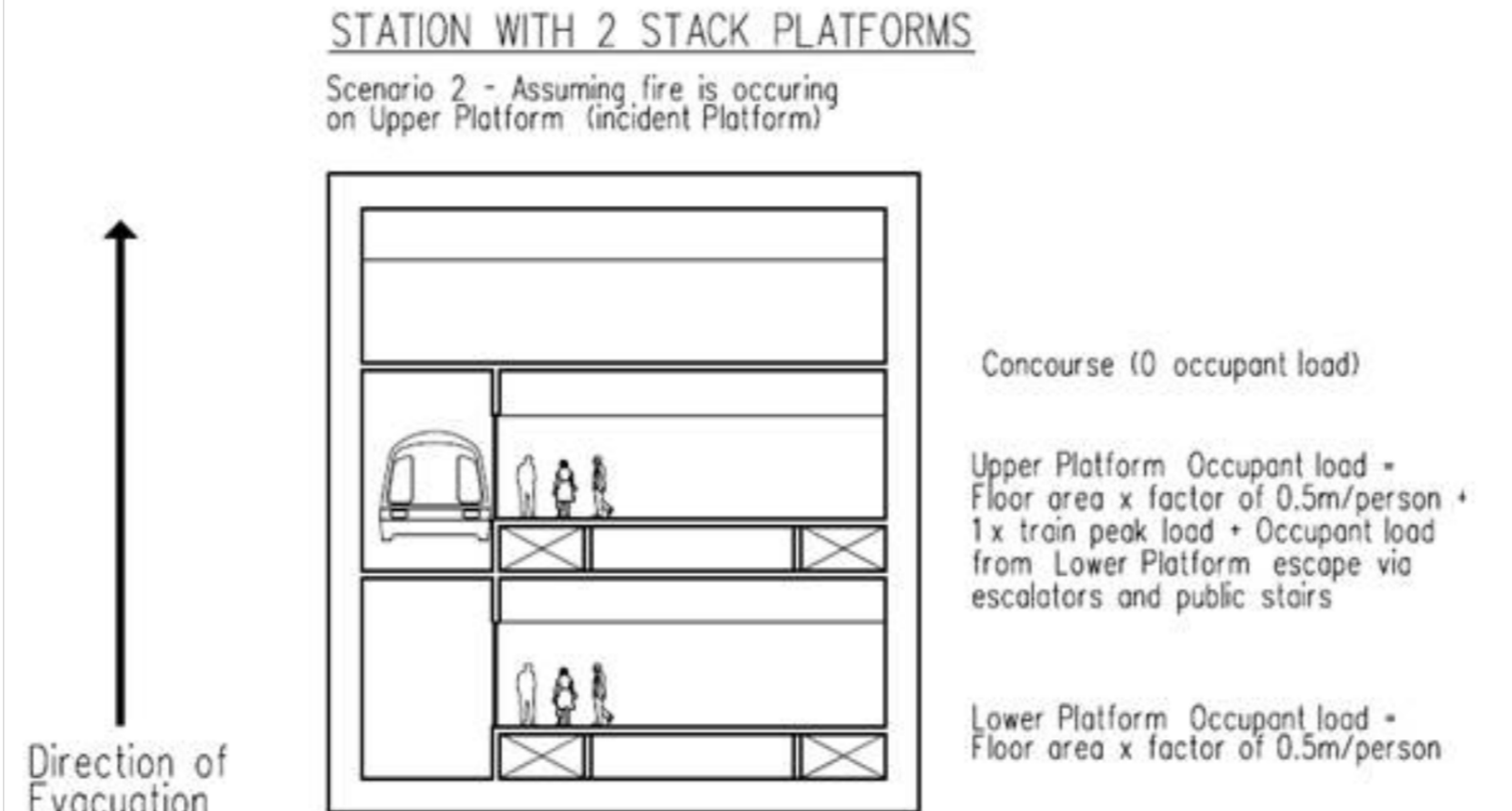

Diagram 2.3.2 - 2

Diagram 2.4.2 - 1 & 2

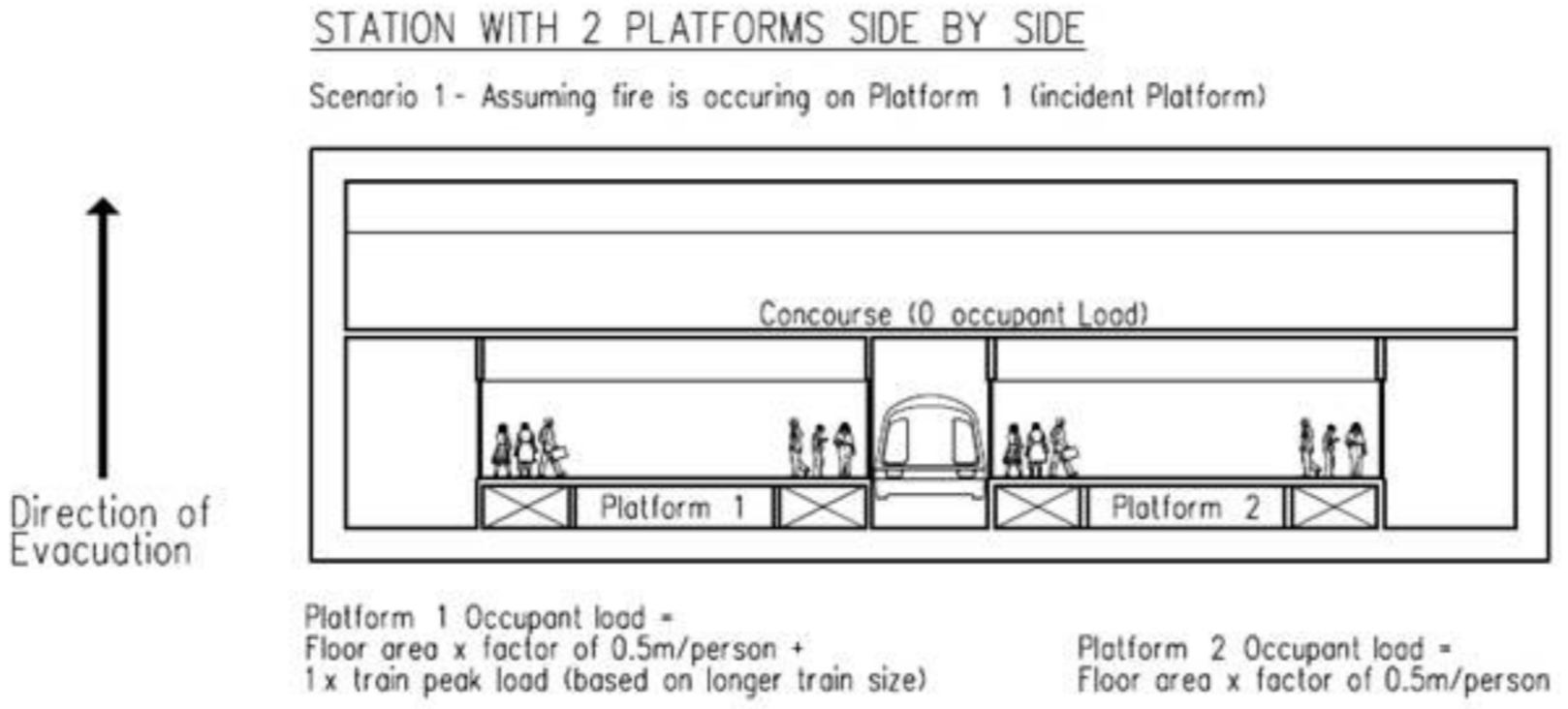

Diagram 2.4.2 - 1

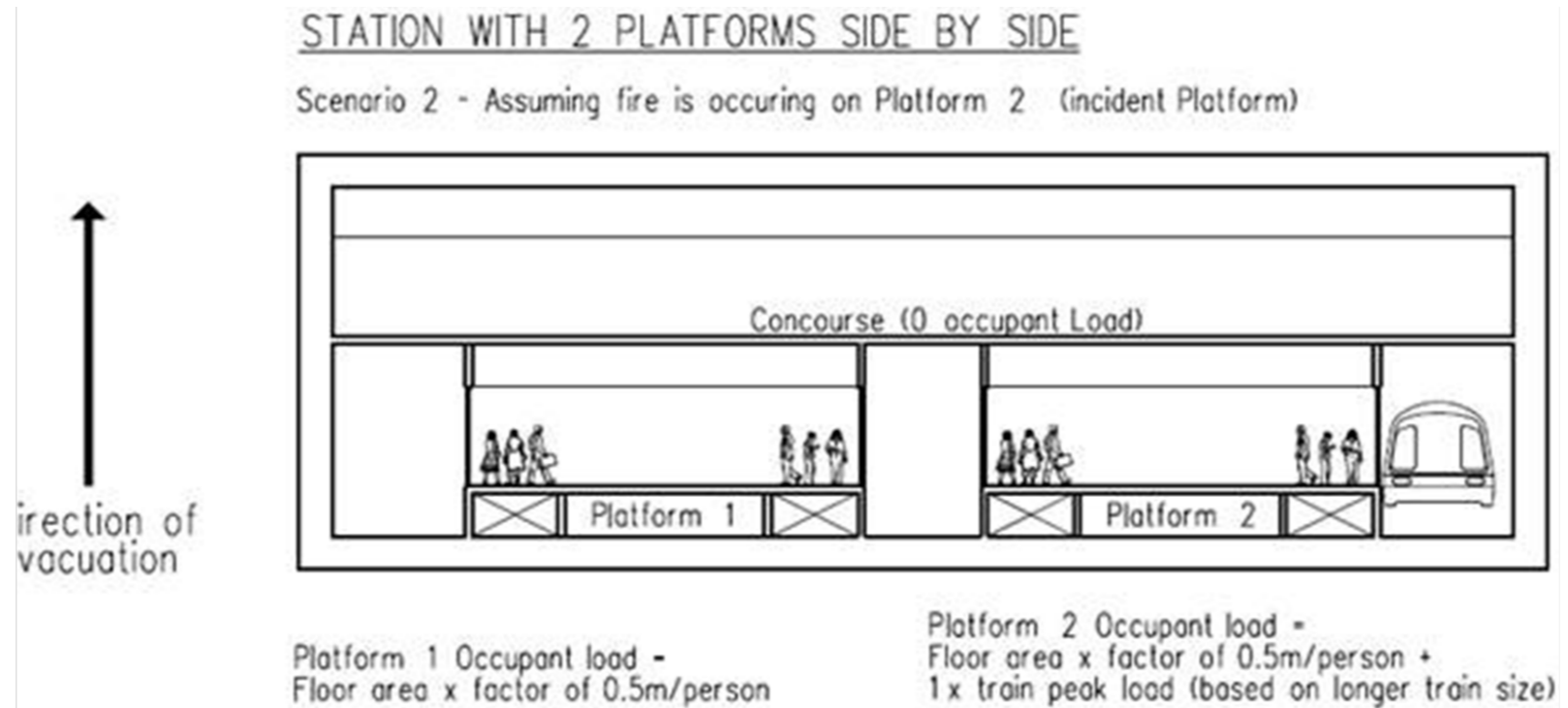

TABLE 2.2.2d.: OCCUPANCY LOAD FOR COMMERCIAL SPACES

TABLE 2.2.2d.: OCCUPANCY LOAD FOR COMMERCIAL SPACES	
FUNTIONAL SPACES	OCCUPANCY LOAD (m ² /person)
Reception Area	3
Lobby/ Corridors	*
Fixed Corridors	*
Waiting Area/ Visitors Lounge	3
Atrium Floor	3
Exhibition/ Promotion Area	1.5
Shop Floor	5
Showroom	5
Supermarket/ Bazaar	5
Department Store	5
Admin. Office	10
Toilets/ Staff Rest Room	*
Storage	30
Mechanical Plant Room	30
Classroom	1.5
Note: * – not considered for occupant load calculation	

TABLE 2.2.3h.: CAPACITY OF MEANS OF ESCAPE

TABLE 2.2.3h.: CAPACITY OF MEANS OF ESCAPE		
Type of Means of Escape	Capacity (p/m/min)	Travel Speed (m/min)
Platforms, corridors, and ramps not more than 4% in slope	80(1)	60
Stairs, escalators, and ramps greater than 4% in slope	60(2)	up 15(3)
		down 18(3)
Doors and gates(5)	80(4)	N/A
Note: (1) – In calculating the capacity of horizontal means of escape routes with a slope not exceeding 4%, 300mm shall be deducted at each sidewall and 450mm at platform edges. (2) – Refer to Cl.2.2.3c.(2) with respect to the allowable means of escape contribution for escalators. (3) – The distance component of travel speed for stairs and stopped escalators is the vertical change in elevation. (4) – Measurement of door width shall be in accordance with Cl.2.2.17c. (5) – Capacity for fare collection gates shall be in accordance with Cl.2.2.3i,		

TABLE 2.2.4f.: CAPACITY OF EXIT FACILITIES

TABLE 2.2.4f.: CAPACITY OF EXIT FACILITIES	
Type of Means of Escape	Capacity (1) No. of person per unit of width (2)
Exit & corridor doors(3)	80
Staircases	60
Ramps, corridors & exit passageways	100
Note: (1) – Where a room or space is required to be provided with two exits, each exit shall be of sufficient width to accommodate at least one half the total occupant load. (2) – In the determination of each exit width, fractions of a unit width less than 250mm shall not be credited. Where 250mm or more are added to one or more full units, half of a unit of width shall be credited. Exit width shall be the clear width of the means of escape. (3) – Measurement of door width shall be in accordance with Cl.2.2.17c.	

TABLE 2.2.4g.: TRAVEL DISTANCE

TABLE 2.2.4g.: TRAVEL DISTANCE			
Occupancy	Means of escape	Maximum travel distance (m)	
		Sprinkler-protected/ Open-to-sky	Non-sprinkler- protected
Commercial	One-way	25	15
	Two-way	60	45
Ancillary*	One-way	30	15
	Two-way	75	60

High hazard	One-way	20	10
	Two-way	35	20

Note:

* See Cl.2.2.4d. for requirements at buffer areas.

In a large floor area without sub-division of rooms, corridors and so forth, the travel distance can adopt the "direct distance" concept as a guide and shall not exceed two-third of the maximum travel distance permitted in this table. Where the large floor area is subdivided into rooms, corridors, etc. the maximum travel distance shall be in accordance with the above table. Furniture, internal partitions and equipment, e.g. air-handling unit, air-con chiller, tunnel ventilation fans, electrical switch board, in rooms can be ignored in determining the direct distance.

TABLE 2.2.171.(2) - 1: PRE-REQUISITES FOR USE OF ELECTROMAGNETIC/ ELECTROMECHANICAL LOCKING DEVICE

Explanation and Illustrations

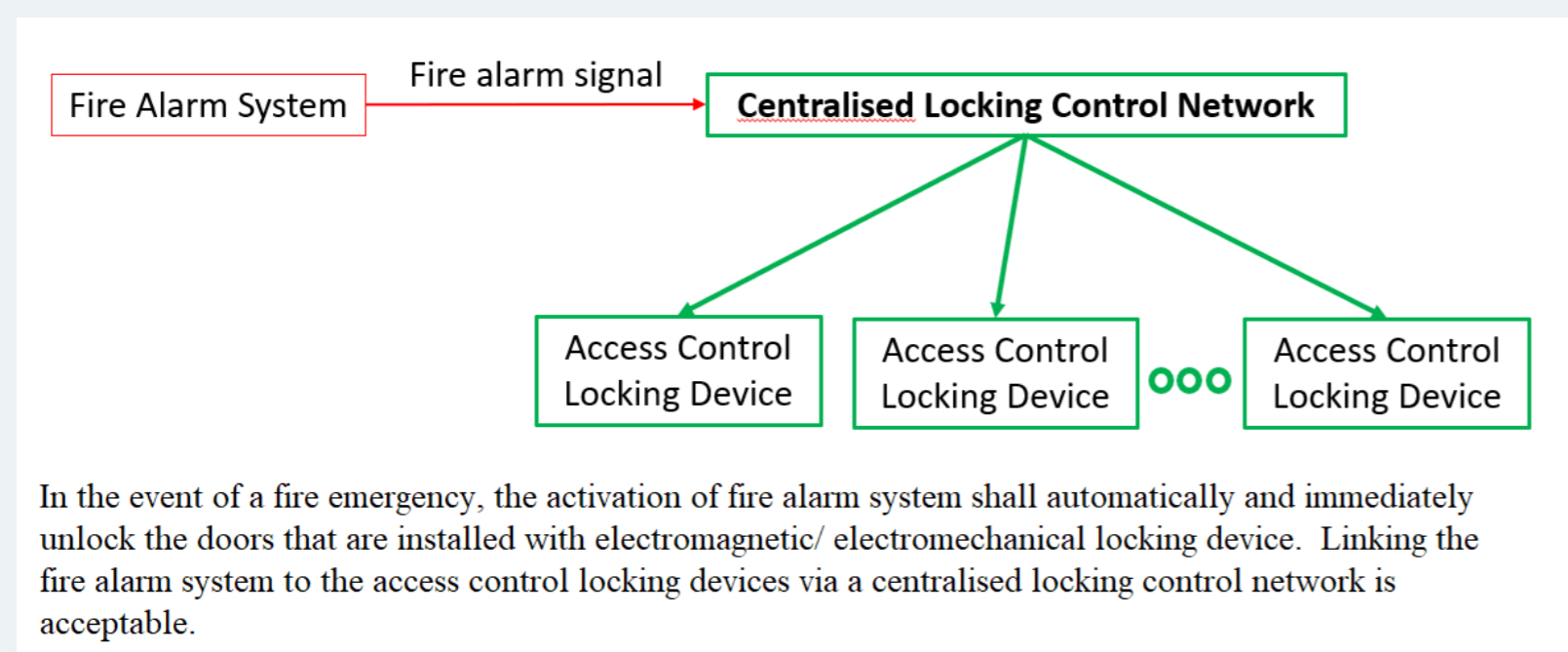

TABLE 2.2.171.(2) - 1: PRE-REQUISITES FOR USE OF ELECTROMAGNETIC/ ELECTROMECHANICAL LOCKING DEVICE

Location	Approved automatic fire alarm or sprinkler systems	Emergency lighting*	Manual override device (Emergency Door Release)**
Exit access doors and/ or exit doors in the escape path for the public.	Yes	Yes	Yes
Doors to access essential rooms for fire protection systems, as stipulated under Cl.8.2.7, except those rooms directly accessed from escape path for the public	Yes	Yes	Yes
Exit access door and/ or exit door to rooms not in the escape path for the public.	Yes	Yes	Yes

Note:

- Linking of the locking devices through other systems to the station fire alarm system or sprinkler system is not permitted.

- Signage complying with SS 508 shall be installed on the egress side of doors reading "Emergency Exit. Door will automatically unlock in case of fire/ emergency".

* Manual override devices shall be provided with a minimum level of illuminance in accordance with SS 563

** Activation of manual override device for emergency door release shall automatically and immediately unlock the doors to facilitate egress. The manual override device shall be located within the occupancy space, 1.2m above the finished floor level and within 1.5m of the door jamb. The manual override device shall be readily accessible and clearly identified by a sign that reads "Emergency Door Release". Any device used by staff for access control to facilitate their day-to-day operations shall not be considered as a substitute for the manual override device. The manual override device, when operated, shall result in direct interruption of power to the lock independent of the control system electronics.

Explanation and Illustrations

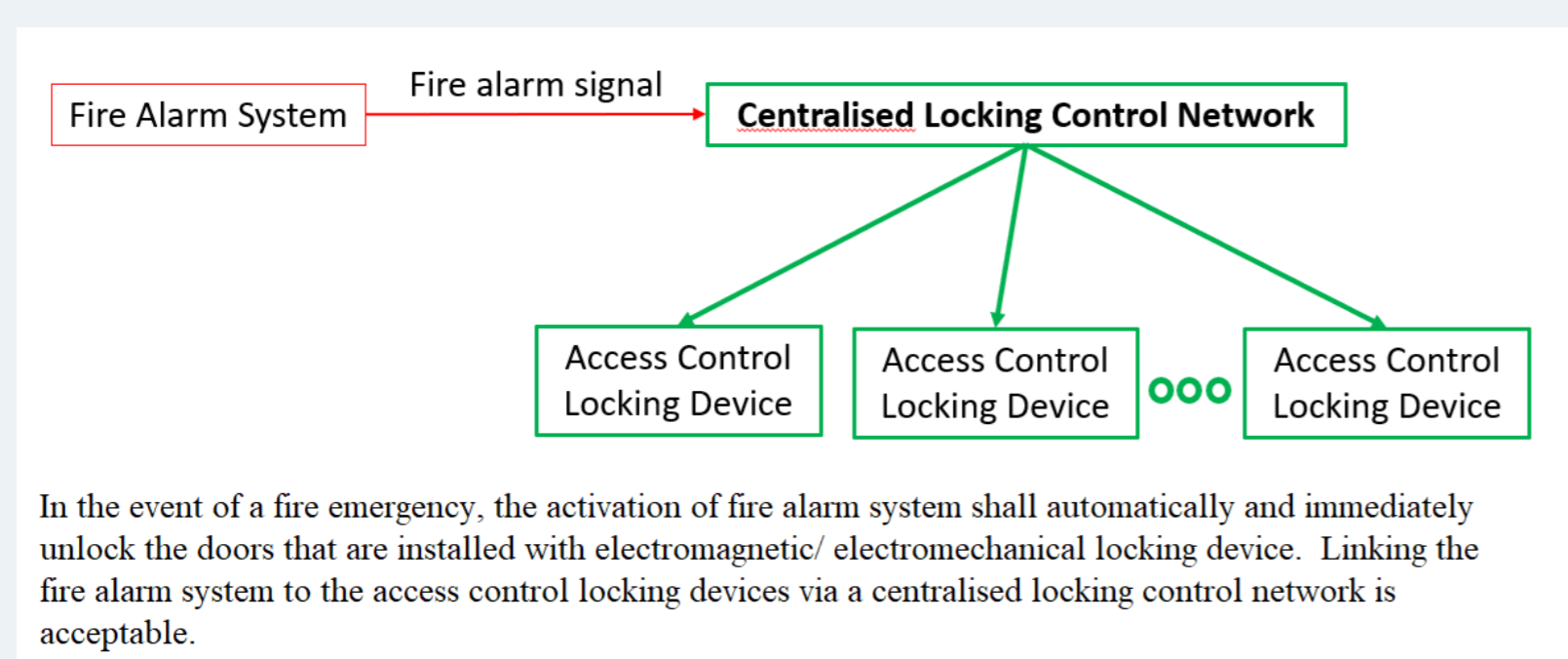

TABLE 2.2.171.(2) - 2: DE-ENERGISE REQUIREMENTS FOR ELECTROMAGNETIC/ ELECTROMECHANICAL LOCKING DEVICE

Location	Any power failure to affected spaces/ areas	Under fire alarm activation	Any fault in the locking devices/ components related to the release of locking mechanism*	Upon activation of a manually operated switch by authorised personnel manning the PSC, or in the absence of which, at the OCC
Exit access doors and/ or exit doors in the escape path for the public	To be released immediately**	To be released immediately	To be released immediately	To be released immediately
Doors to access essential rooms for fire protection systems, as stipulated under Cl.8.2.7, except those rooms directly accessed from escape path for the public	Release not required	To be released immediately	Release not required	Release not required
Exit access door and/ or exit door to rooms not in the escape path for the public.	Release not required	Release not required	Release not required	Release not required

Note:

* Excluding faults on other access control devices such as card readers, override key switches, non-emergency exit buttons, etc.

** Electromagnetic/ Electromechanical locking device can be manually re-engaged after it has been released, provided such a device complies with the following:

(1) There is no activation of any fire detection system and it has been visually verified that there is no fire; and

(2) A device to re-engage the Electromagnetic/ Electromechanical locking shall be provided at the PSC or OCC, if PSC is not avail

ANNEX 2A - EXITING ANALYSIS

A.1 GENERAL

A.1.1 Evacuation times

As described in [Chapter 2](#), there shall be sufficient exit capacity to clear the platform occupant load from the station platform in 4 minutes or less, and the station shall be designed to permit evacuation from the most remote point of the platform to a point of safety in 6 minutes or less.

A.1.2 Time to clear platform/ Platform exits flow time

Platform exit time is the time required to clear all the platform occupant load from the platform according to the formula:

Time to clear platform

= Platform exits flow time

= Platform Occupant Load/ Platform Exit Capacity

A.1.3 Station evacuation time

The time to evacuate from the most remote point of the platform to a point of safety is the sum of the walking travel time for the longest exit route plus the waiting time at the various circulation elements.

A.1.4 Walking travel time

The walking travel time is calculated using station geometry data and the travel speeds indicated in [Cl.2.2.3h](#). The exit route is broken down into segments and tabulated. The travel distance for each segment is then divided by the appropriate travel speed to determine the time needed to traverse each segment. The walking travel time is the sum of the times for each segment.

A.1.5 Flow time

The flow time (the time for the last person to through the particular element) for each of the various circulation elements (e.g. stairs/ escalators, fare collection gates, doors, etc.) is calculated using the capacities and conditions specified in [Chapter 2](#).

A.1.6 Care must be taken to be sure that the most restrictive circulation elements are included in the calculations.

For instance, if a 1m wide single-leaf door provides access to a 1.2m wide stair, the door and the stair would be considered to provide a capacity of 80p/min and 72p/min respectively in accordance with [Cl.2.2.3h](#). In this case the stair is more restrictive than the door, meaning that the stair shall be used in the capacity calculation.

A.1.7 Where exit paths divide, i.e. where a choice of exit paths is presented, it is presumed that the passengers will divide into groups roughly in proportion to the exit capacity provided by the various paths at the decision point. It also is presumed that passengers, once having made a decision (selecting an exit path), will stay on that path until another decision point is reached or egress is achieved.

A.1.8 Waiting time of circulation elements

The waiting time at each of the various circulation elements is calculated, for the platform exits, by subtracting the walking travel time on the platform from the platform exits flow time, and for each of the remaining circulation elements, by subtracting the maximum of all previous element flow times.

A.2 CENTRE PLATFORM STATION

A.2.1 The sample centre platform station shown in Figure A-2.1 is an underground station with the concourse above the platform level but below grade. The platform public area is 60m long to accommodate the train length. The vertical distance from the platform to the concourse is 5m. The vertical distance from concourse to grade is 8m.

The station has two entrances normally used by passengers. Each of these entrances has two escalators of 1m clear width and one stair of 2m clear width. The entrances are covered at grade level to a point 9m beyond the top of the stair landing.

The station concourse level has one paid area separated from the unpaid area. At two ends of the paid area, there are 8 electronic fare gates and a 1m wide emergency gate. The open well at the centre of the concourse level communicate with the platform level. Each end has one stair of 2m clear width and two escalators of 1m clear width. Station ancillary areas are located at the two ends of the platform and concourse level.

The station occupant load is 1200 persons.

In Test #1 of Figure A-2.2, the time to clear the platform is found to be 2.86 mins. This meets the requirement of [Cl.2.2.3d](#). The sample calculation shows the effect of discounting one of the escalators from platform to concourse for the escape route to the right of the station.

In Test #2 of Figure A-2.2, the time to reach a point outside any enclosing structure for Escape Route 1 and Escape Route 2 are found to be 4.45 mins. They meet the requirement of [Cl.2.2.3e](#).

Additional calculations must also be made to examine the results of discounting an escalator at other locations to verify that the exit time under those conditions can still comply with [Cl.2.2.3e](#).

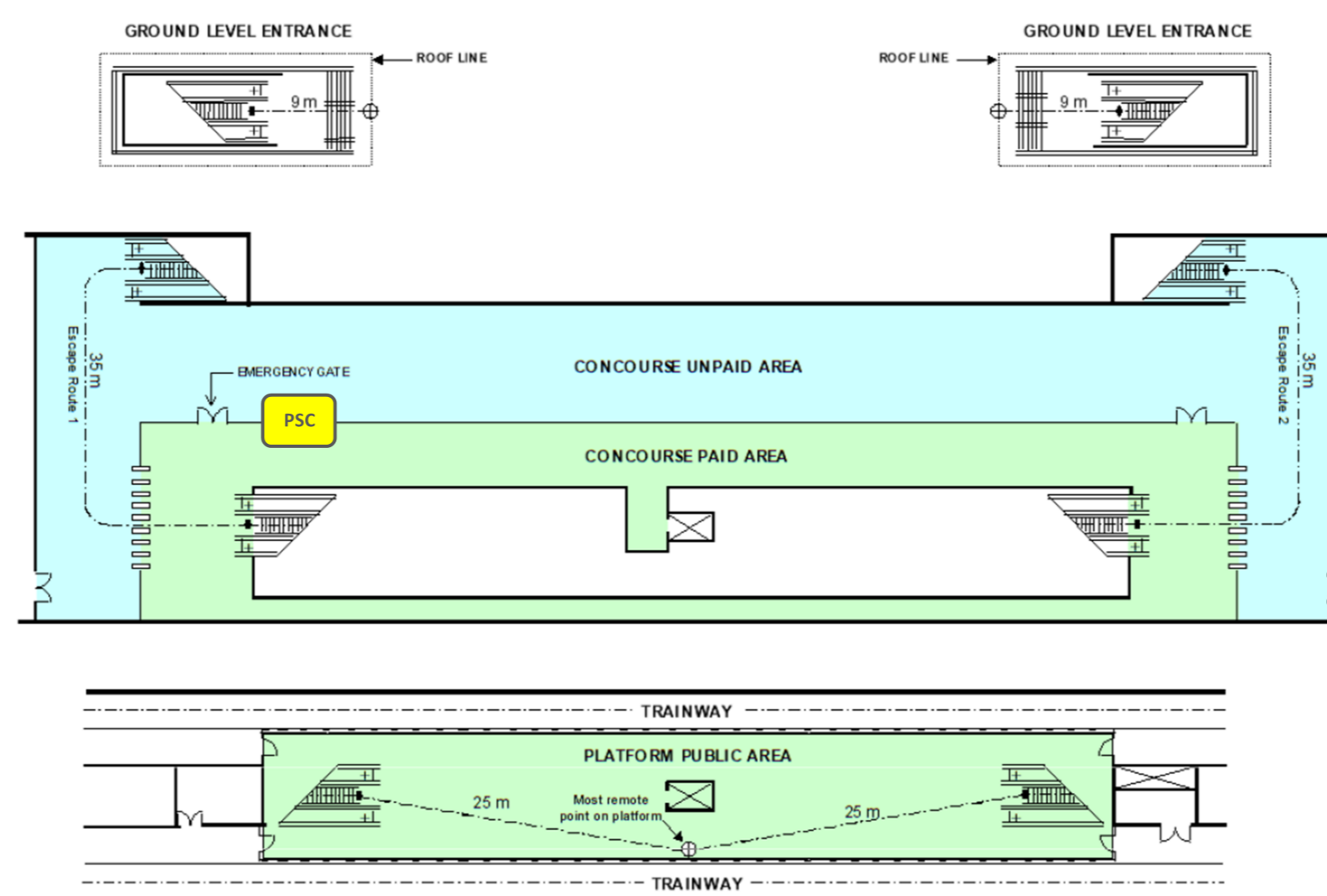

Figure A-2.1: Centre Platform Station

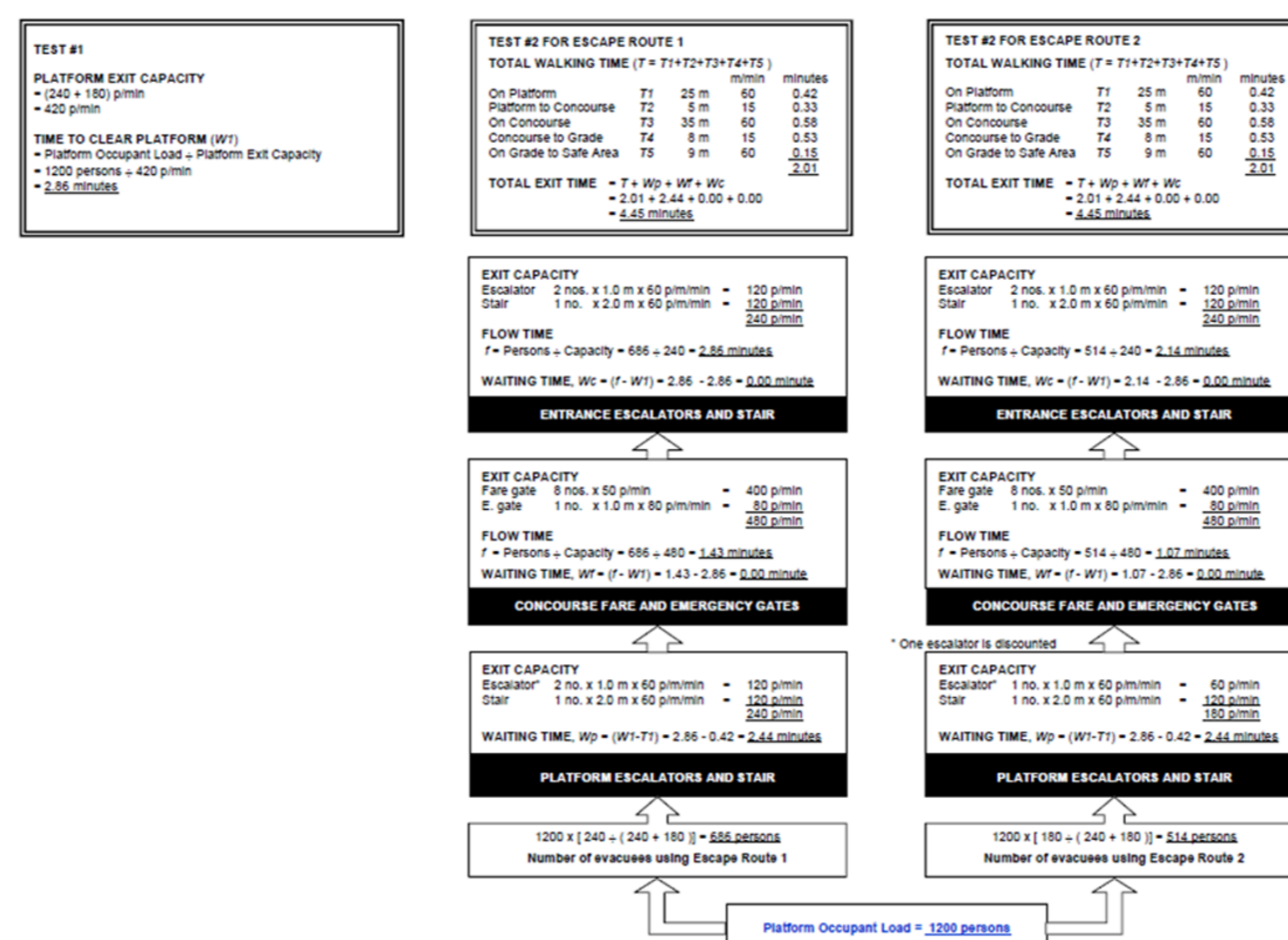

Figure A-2.2: Egress Analysis

Clause No.	Amendment Date	Effective Date	Clause Status	Clause Before Amendment	Circular Date
------------	----------------	----------------	---------------	-------------------------	---------------

CLAUSE 3.1 GENERAL

The purpose of this Chapter is to stipulate requirements to minimise the risk of spread of fire between the station and adjoining buildings by separation, prevent the untimely collapse of stations in the event of fire by the provision of a stable and durable form of construction and prevent the spread of fire between specified parts of the stations by the division of such stations into compartments.

Explanation and Illustrations

Structural fire precautions relate to the insulation, integrity and stability of station elements during fire for the required period of time. "Structural" does not only apply to the structural elements of station but other station components, e.g. doors, shafts, walls/ ceiling finishes.

CLAUSE 3.2 PROVISION OF COMPARTMENT WALLS AND COMPARTMENT FLOORS

3.2.1 Compartment size - floor area & cubical extent

Rationale

Compartmentation serves to reduce the rate of fire spread to enable safe evacuation and firefighting in stations. It also serves to isolate high risk areas from other parts of a station.

Any station which has:

- Any storey the floor area of which exceeds that specified as relevant to a station of that height in column (2) of [Table 3.2A](#), or
- A cubic capacity which exceeds that specified as so relevant in column (3) of [Table 3.2A](#),

shall be divided into compartments by means of compartment walls and compartment floors so that:

- no such compartment has any storey with a floor area of which exceeds the area specified as relevant to the station in column (2) of [Table 3.2A](#); and
- no such compartment has a cubic capacity which exceeds that specified as relevant in column (3) of [Table 3.2A](#).

Exception: Size limitation of compartment shall not apply to the public area below ground level. Compartment size for public area below ground level shall comply with [Cl.3.2.4e](#).

3.2.2 Cubical extent for compartment

- Compartment exceeding 4m in height

In computing the cubical extent of compartments, the height of 4m shall be used where the actual height exceeds that figure.

If any compartment contains mezzanine, galleries or lofts, the full height of the compartment shall be used in computing the cubical extent.

- Open-side covered walkway/ link-bridge

Where station is connected to another station or building by external open-sided covered walkway or open-sided covered link-bridge, the station/ building is considered as separate station or building, if they comply with the following conditions:

- There is no commercial activities or other usage that would pose a fire risk within the covered walkway or link-bridge.
- The width of the covered walkway or covered link-bridge shall not exceed 6m clear width.

Rationale

The 4m in height serve as a relaxation for purpose of computing cubical extent, instead of using the actual height. The consideration takes into account that such spaces are meant to be circulation.

Explanation and Illustrations

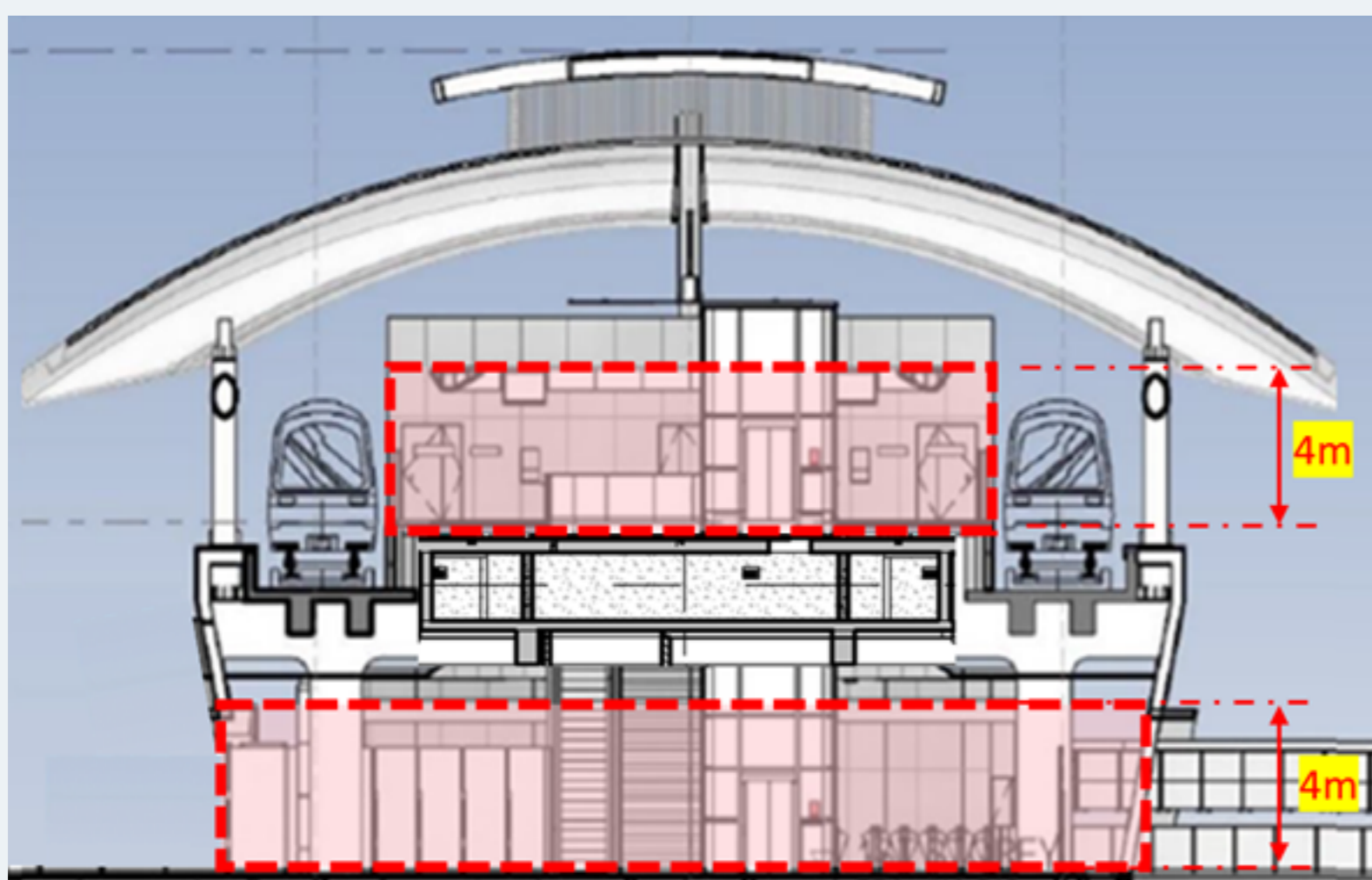

3.2.3 Compartmentation by height

- In any compartment up to a habitable height of 24m, no compartment shall comprise more than three storeys.
- In any station which exceeds 24m in habitable height, no compartment shall comprise more than one storey for compartments at storey level exceeding 24m above average ground level.

3.2.4 Situations requiring compartmentation

The following situations shall require compartmentation by provision of compartment walls and/ or compartment floors:

- Separation of transit and non-transit occupancies

Transit and non-transit occupancies shall have a fire separation of at least 2-hrs. Stations connected to non-transit occupancies shall comply with the relevant requirements of [Chapter 9](#).

- Separation of public and ancillary areas

- All public areas shall have a fire separation of at least 2-hrs from ancillary areas.

- Exception

- Fire separation shall not apply to Passenger Service Centre, station master room, ticketing office and enclosures housing ticket vending machines.

Explanation and Illustrations

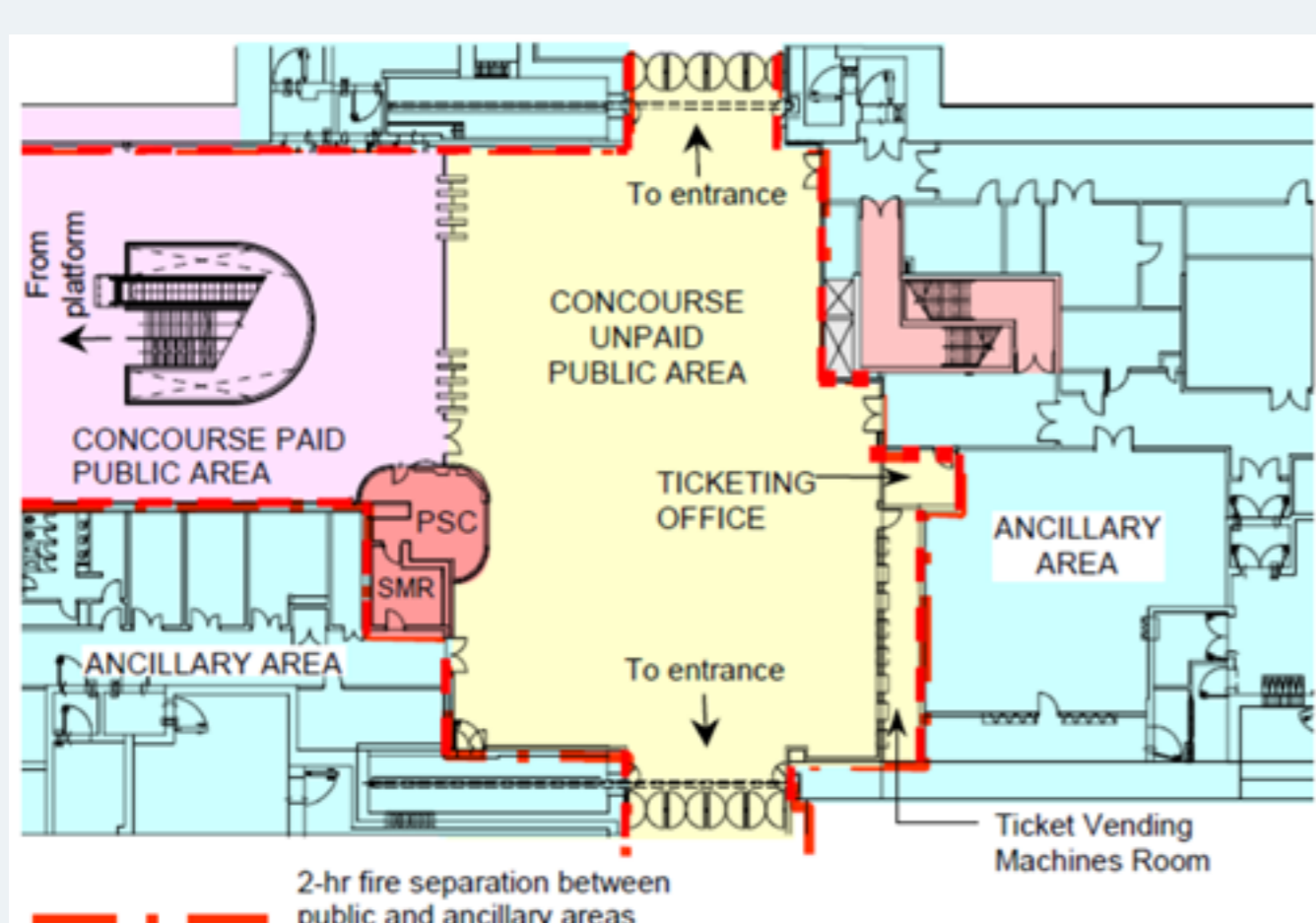

(b) Platform public areas need not be fire separated from the trainway and buffer areas.

c. Separation of commercial spaces

(1) Commercial spaces shall be compartmented by having not less than 2-hrs fire resistance construction. If sprinkler protection is provided, the fire resistance rating can be reduced to at least 1-hr.

Explanation and Illustrations

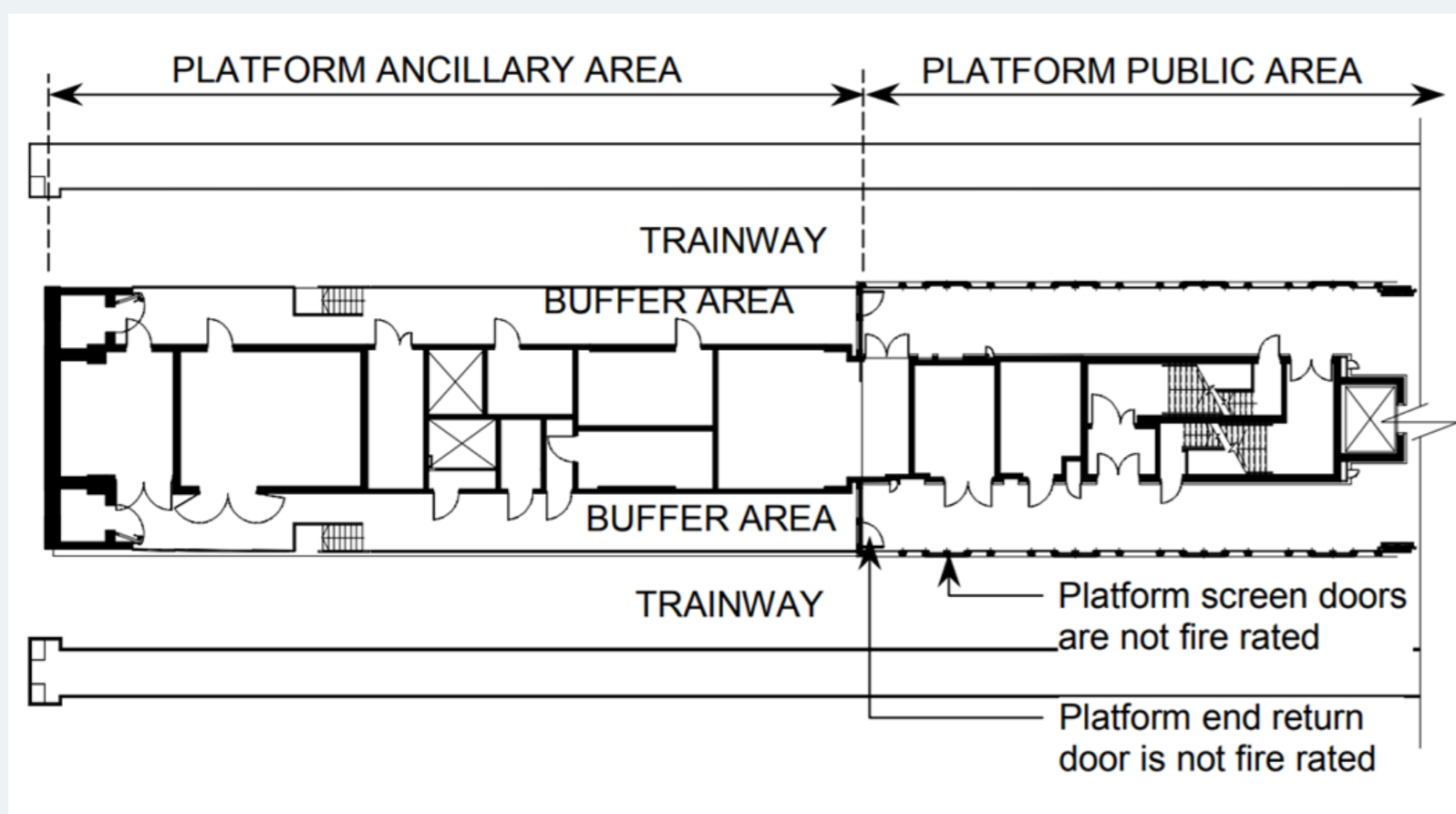

(2) Shops with a maximum aggregated area of 115m² (where no individual shop unit shall exceed 100m²) are allowed in the public area except at platform level. The shops can be subdivided into several smaller units by fire compartments. Where the concourse is located on the same level as the platform, no shops shall be permitted.

(3) Exception

(a) Additional commercial spaces shall be permitted in stations, provided these commercial spaces are located on a separate level other than the platform and concourse levels and comply with the relevant requirements in the Code of Practice for Fire Precautions in Buildings. Fire separation is required only at the periphery around the large commercial space as shown in [Diagram 3.2.4c](#).

(b) Where commercial spaces at the ground level of station entrances of underground stations are not located along the station's means of egress, and smoke generated from a fire in the commercial spaces will not be drawn into the station, these commercial spaces are not required to be compartmentalised.

(c) Commercial spaces in aboveground stations

(i) Where commercial spaces in above ground stations are not located along the station's means of egress and are located more than 6m from the edge of the guideway, these commercial spaces are not required to be compartmentalised.

(ii) That parts of the external wall and roof of commercial spaces in aboveground stations not located along the station means of egress and more than 6m from the edge of the guideway, are not required to be fire-rated.

(iii) For aboveground or elevated stations, there is no restriction on the unpaid area taken up by shops after the point of safety or other locations stipulated in [Cl.2.2.3e](#).

Rationale

To allow flexibility in the sizing and location of shops at concourse level but still maintaining their aggregate area of not more than 115m². Instead of mandating one big shop and one small shop units, the revision now permits the one big shop to be further subdivided to smaller units by fire compartments.

d. Separation between viaduct and M&E plantrooms/ commercial spaces

For aboveground stations, M&E plantrooms and commercial spaces located directly beneath and within 3m of the viaduct shall be compartmentalised from the viaduct by a fire resistance construction of not less than 2-hrs. If sprinkler protection is provided, the fire resistance rating can be reduced to at least 1-hr.

e. Basement floors

In any compartment below ground level, no compartment shall comprise more than one storey, except for the public area which shall not exceed 3 storeys per compartment.

f. Special purpose rooms

Special purpose rooms shall be compartmentalised in accordance with [Table 6.4A](#).

g. Areas of special hazard

(1) Transformer rooms, generator rooms, and any other area of special high risk shall be separated from other parts of the station by compartment walls and floors having fire resistance of at least 4-hrs. However, for transformer rooms which do not utilise flammable liquid, they shall be separated from other parts of the station by compartment walls and floors having fire resistance of at least 2-hrs;

(2) Room housing transformer that uses flammable liquid shall be located at ground level against an external wall; and

Explanation and Illustrations

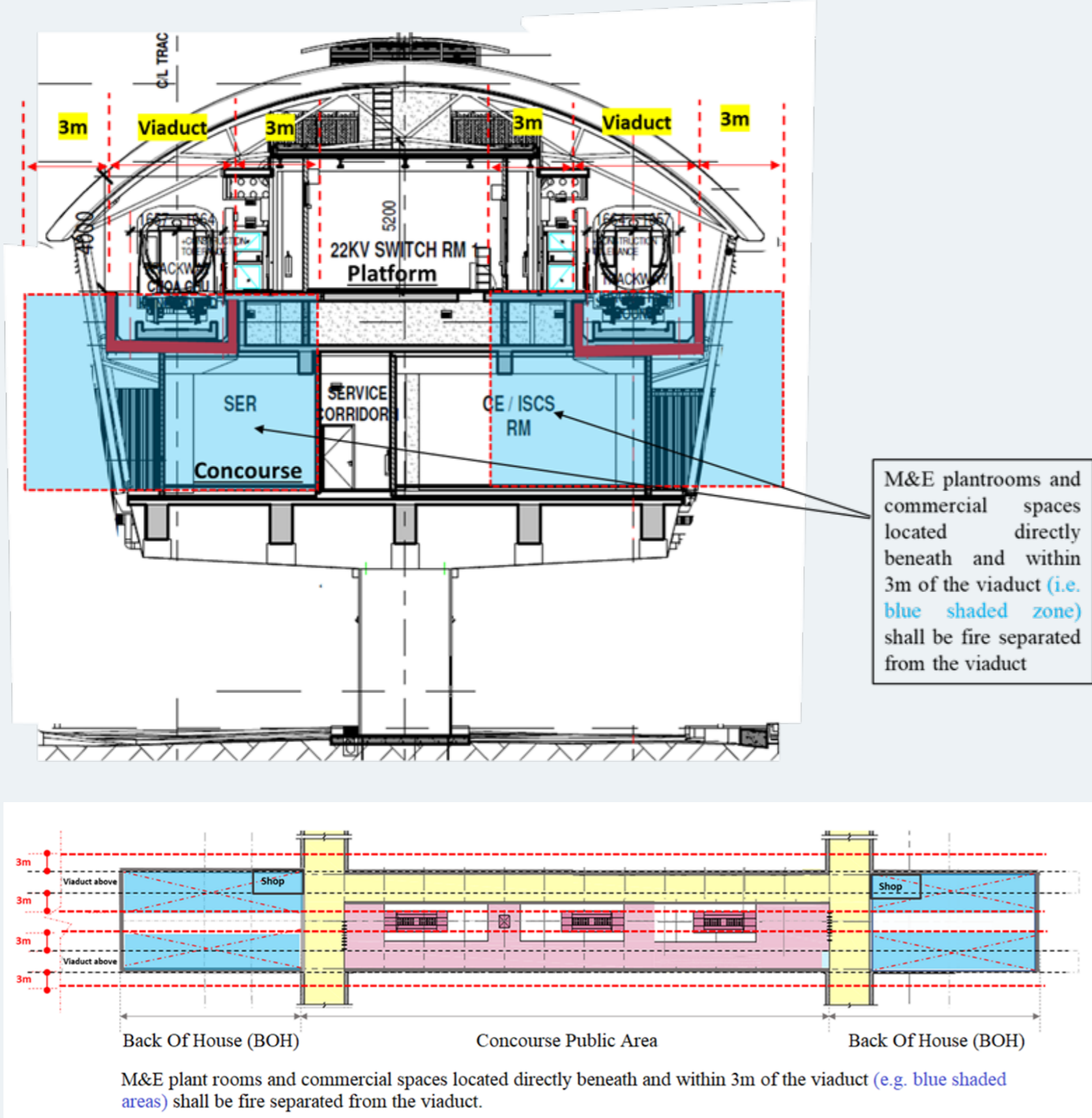

(3) Diesel fuel tank for emergency generator need not be located against an external wall

h. Coldroom

Coldroom shall comply with the prevailing Code of Practice for Fire Precautions in Buildings.

Rationale

Room for dry transformer or transformer using non-flammable liquids or generator in underground stations is not required to be located against an external wall. This is because the flash point of diesel is above 60°C and thus not deemed highly flammable.

i. Underground bicycle parking area for transit occupants

Underground bicycle parking area including the bicycle kiosk shall be compartmentalised from the station public area with at least one dedicated exit staircase and exit access door to station public area; sprinkler-protected and provided with smoke purging system. The bicycle kiosk's size shall be limited to 30m². Types of trades and services permitted in the stations are given in [Table 1.4A](#) – Code H.

Rationale

The underground bicycle parking area and kiosk are additional spaces and not part of 100m² and 15m² commercial spaces.

Underground bicycle parking area and bicycle kiosk will be provided for some of the new underground stations. As the fire risk for the underground bicycle parking area and bicycle kiosk is unlikely to be higher than that of underground car park, its smoke control system can follow that of underground car park i.e. smoke purging system. Engineered smoke control system is not required.

The bicycle kiosk is restricted to only servicing, repairs and cleaning of bicycle and also limit to selling of bicycle accessories and spare parts. This kiosk is also not allowed for sale or storage paint, solvent, thinner and bicycle batteries. Charging of battery activity for motorised bicycle is strictly not allowed in the bicycle parking area.

3.2.5 Permitted appliances within station

The conditions for appliances permitted within the station shall be as follow:

a. Automatic vending machines

Clusters of automatic vending machines are allowed in the public (unpaid) area except at platform. Each cluster of vending machines shall consist of not more than two vending machines and clusters of vending machines shall be placed at least 1m apart.

b. Light-emitting diode (LED) digital screens

LED digital screens installed at the transit station shall not impede passenger flow/ evacuation and shall not block visibility of exit signs. Clusters of LED digital screens are allowed in the transit station. Each cluster of LED digital screens shall not have more than two LED digital screens and clusters of LED digital screens shall be placed at least 2m apart.

Rationale

LED digital screens support the operation needs of the transit station. They serve as a primary means of providing general information on train services and may be used for commercial or advertising purpose. The separation distance between the clusters of LED digital screens will prevent fire spread between them.

CLAUSE 3.3 FIRE RESISTANCE OF ELEMENTS OF STRUCTURE

3.3.1 Interpretation and application

The interpretation and application of Cl.3.3 shall be as follows:

- a. Subject to the provisions of sub-clause b. and any other expressed provision to the contrary, any reference to a station of which an element of structure forms a part means the station or (if the station is divided into compartments) any compartment of the station of which the element forms a part;
- b. Any reference to height means the height of a station, but if any part of the station is completely separated throughout its height both above and below ground from all other parts by a compartment wall or compartment walls in the same continuous vertical plane, any reference to height in relation to that part means the height solely of that part;
- c. If any element of structure forms part of more than one station or compartment and the requirements of fire resistance specified in Cl.3.3.2 in respect of one station or compartment differ from those specified in respect of any other station or compartment of which the element forms part, such element shall be so constructed as to comply with the greater or greatest of the requirements specified; and
- d. If any element of structure is required to be of non-combustible construction, the measure of fire resistance rating shall be determined by the part which is constructed wholly of non-combustible materials.

3.3.2 Minimum periods of fire resistance

Subject to any expressed provision to the contrary, any element of structure shall be constructed of non-combustible materials and is required to have fire resistance for at least the relevant period specified as follows:

- a. The fire resistance of elements of structure for aboveground stations shall be not less than 2-hrs.
- b. The fire resistance of elements of structure for underground stations shall be as follows:

Explanation and Illustrations

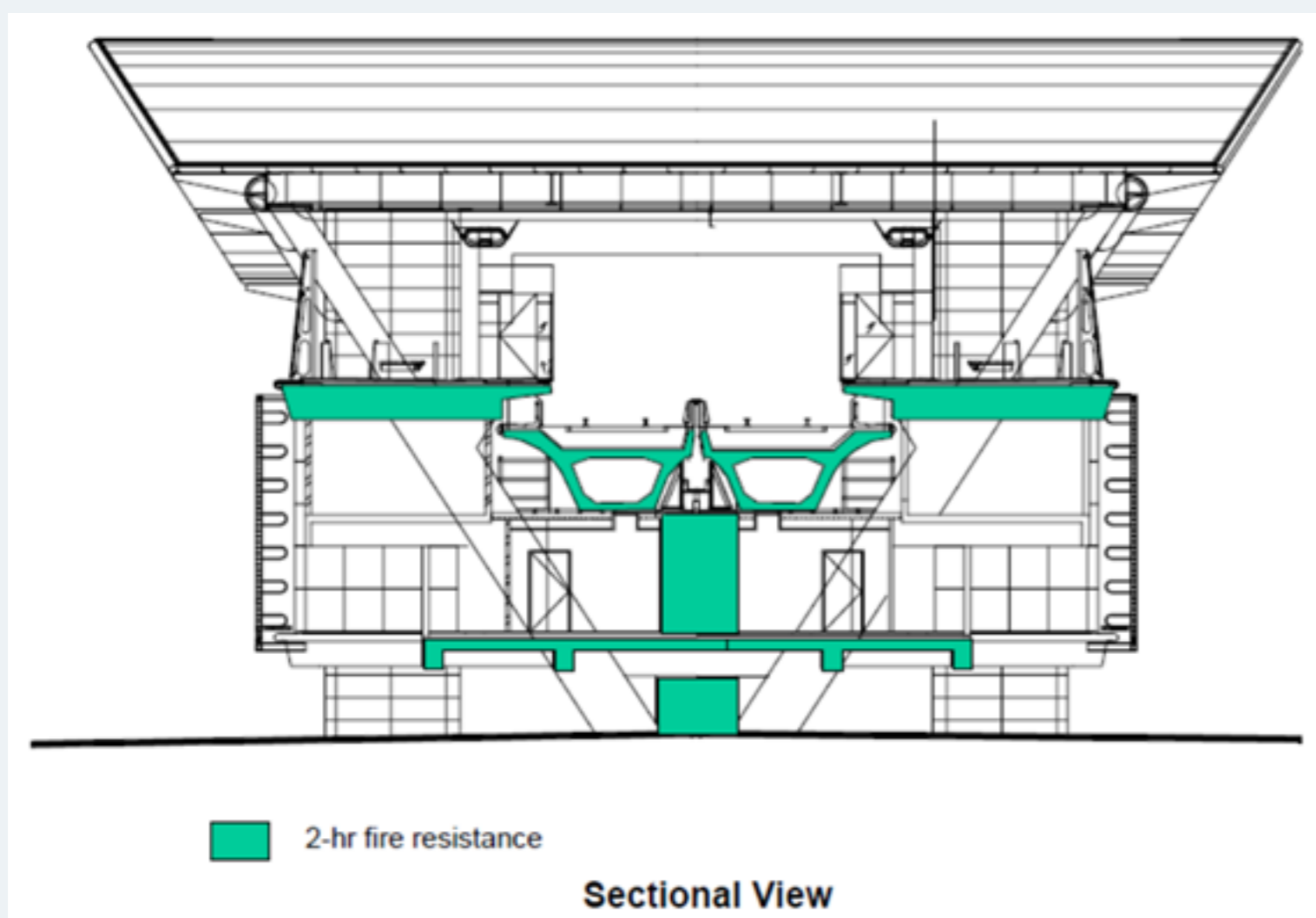

- (1) Structure member forming part of the structural frame of a station – 4 hrs
- (2) Load bearing wall or load bearing part of a wall – 4 hrs
- (3) Floor – 4 hrs
- (4) Separating wall – 2 hrs
- (5) Compartment wall – 2 hrs
- (6) Structure enclosing a protected shaft – 2 hrs

Explanation and Illustrations

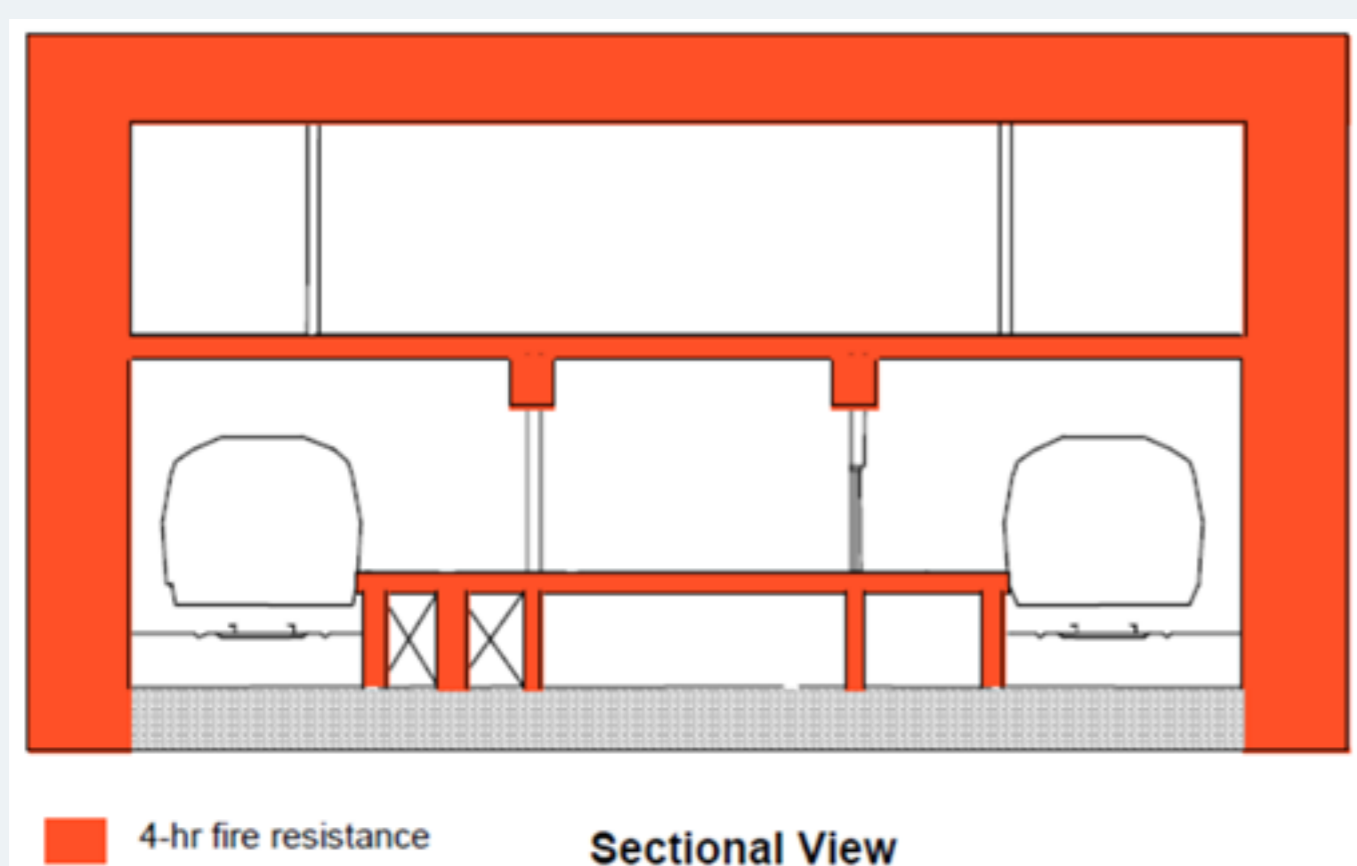

- c. Where there are habitable floors directly above a trainway within an aboveground station, the fire resistance of elements of structure around the trainway within the station shall be not less than 4 hrs as shown in Diagram 3.3.2c.

3.3.3 Exemption for non-loadbearing external walls

The requirement on fire resistance in Cl.3.3.2 shall not apply to any part of any external wall which is non-loadbearing and can, in accordance with Cl.3.5 be an unprotected area.

3.3.4 Exemption for single storey structure

In the case of a station consisting of a first storey and one or more basement storeys, nothing in Cl.3.3.2 shall apply to any element of structure which forms part of the first storey and consists of:

- a. A structural frame, beam, or column, provided that any beam or column (whether or not it forms part of a structural frame) which is within or forms part of a wall, and any column which gives support to a wall or gallery, shall have fire resistance of not less than the minimum period, if any, required by this Code for that wall or gallery, or
- b. An internal loadbearing wall or a loadbearing part of a wall, unless that wall or part is, or forms, part of a compartment wall or a separating wall, or forms part of the structure enclosing a protected shaft or supports a gallery, or
- c. Part of an external wall which does not support a gallery, and which can, in accordance with Cl.3.5 be an unprotected area.

3.3.5 Suspended ceiling

In determining the fire resistance of floors, no account shall be taken of any fire resistance attributable to any suspended ceiling unless the ceiling is constructed specifically as a fire protecting suspended ceiling.

3.3.6 Fire-rated board for steel structure

Fire-rated boards are permitted to be used for protection to structural steel beams, columns, and wall construction in station if all the following are complied with:

- a. The fire-rated boards shall be non-combustible (BS 476: Part 4 or Part 11);

- b. It shall have a fire resistance rating at least equal to that of elements of structure required under [Table 3.4A](#);
- c. It shall meet the criteria, in terms of water absorption and bending strength performance, when subject to test of BS EN 520 (for gypsum plaster board) or ISO 1896 (for calcium silicate or cement board); and
- d. The fire-rated boards shall be constructed to be in contact with the steel column. If it is unavoidable, the void space between the fire-rated board and the steel column shall be adequately filled to a height of 1.2m, measured from finished floor level, with fire protective material such as concrete, gypsum or grout to prevent any possible denting of the boards; and
- e. There shall be no services running in the space between the steel structure and fire-rated boards, unless these services are encased in concrete or run in steel conduits.

CLAUSE 3.4 TEST OF FIRE RESISTANCE

3.4.1 Fire resistance

Performance for the fire resistance of elements of structure, doors and other forms of construction shall be determined by reference to the methods specified in BS 476: Part 20 to 23, which specify tests for stability, integrity, and insulation.

Specific requirements for each element in terms of the three performance criteria of stability, integrity and insulation are given in [Table 3.4A](#).

3.4.2 “Deem to satisfy” provision

An element of structure, door or other part of a station shall be deemed to have the requisite fire resistance if:

- a. It is constructed to the same specification as that of a specimen exposed to test by fire in accordance with the method and procedure under BS 476: Part 20 to 23, and satisfied the requirements of that test for the three performance criteria of stability, integrity, and insulation for not less than the specified period, or
- b. In the case of a wall, beam, column, stanchion, or floor to which [Annex 3B](#) relates, it is constructed in accordance with one of the specifications set out in that Annex and the notional period of fire resistance given in that Annex as being appropriate to that type of construction and other relevant factors is not less than the specified period, or
- c. In the case of structural concrete, it is constructed to comply with SS EN 1992 Part 1 and 2.

CLAUSE 3.5 EXTERNAL WALL

3.5.1 Requirements of external walls

External walls (including any external cladding or internal lining) shall:

- a. Be constructed wholly of non-combustible materials.
- b. Be so constructed as to attain the fire resistance required by this Code.

3.5.2 Unprotected areas in any side of a station

Unprotected areas in any side of a station shall comply with all the following:

- a. Any relevant requirements relating to the permitted limits of unprotected areas specified in [Annex 3B](#) unless the station is so situated that such side can in accordance with [Annex 3B](#) consist entirely of any unprotected area.
- b. The extent of unprotected openings in an external wall of a station in relation to its distance from the lot boundary can be double that which is specified in [Annex 3B](#) when the station or compartment is fitted throughout with an automatic sprinkler system in compliance with the requirements in [Chapter 6](#).
- c. For the calculations of unprotected areas, platform public areas shall be excluded from the unprotected openings calculation.
- d. Where a ground level entrance of an underground station is a single storey structure with no habitable room, the distance 'X' between the external wall of the entrance and the external wall of an adjacent building as shown in [Diagram 3.5.2d.](#), shall comply with the distance stipulated in [Annex 3B](#) based on the extent of unprotected openings in the external wall of the adjacent building.

3.5.3 External wall finishes

Cladding on external walls shall be of non-combustible construction.

3.5.4 Reference to Annex 3B

Any reference to [Annex 3B](#) shall be construed as referring to the provisions of [B.1](#) of that Annex together with (at the option of the person intending to erect the station) the provisions of [B.2](#).

3.5.5 Stations on land in common occupation

If two or more detached stations are erected on land in common occupation, any external wall of any station so erected which faces an external wall of such other station, the relevant boundary shall be a notional boundary passing between those stations and such boundary must be capable of being situated in such a position as to enable the external walls of those stations to comply with the requirements of [Cl.3.5.2](#).

3.5.6 Vertical fire spread

Rationale

The purpose of providing high/ low separation is to ensure fire will not spread from the lower compartment to the abutting higher compartment of the station.

For high and low parts of different compartments of a station abutting each other, either one of the following requirements shall be complied with to prevent spread of fire between the distinct parts:

- a. The roof over the lower part of the station shall be fire-rated in accordance with the element of structure for minimum 1-hr for a distance of 5m measured horizontally from the external wall of the higher part of station; or
- b. The external wall of the higher part of the station overlooking the roof below shall have the necessary fire resistance rating in accordance with the element of structures for minimum 1-hr for a vertical height of not less than 9m measured from the roof of the lower part of the station.

CLAUSE 3.6 SEPARATING WALLS

3.6.1 Every separating wall shall:

- a. Form a complete barrier in the same continuous vertical plane through the full height between the building and station it separates, including roofs and basements, shall be imperforate except for provisions of openings permitted under [Cl.3.6.2](#);
- b. Have the appropriate fire resistance to comply with the requirements of [Cl.3.3](#);
- c. Be constructed of non-combustible materials, together with any beam and column which form part of the wall and any structure which it carries; and
- d. Not include glass fire resisting walls.

3.6.2 Openings in separating walls

A separating wall shall have no openings except for:

- a. A door required to provide a means of escape in the event of a fire, having the same fire resistance as that required for the wall and complying with [Cl.3.9.2](#), or
- b. A door provided for the purpose of public circulation, having the same fire resistance as that required for the wall and complying with [Cl.3.9.2](#), or
- c. An opening for the passage of a pipe complying with the relevant provisions of [Cl.3.9.3](#).

3.6.3 Roof junction

A separating wall shall be either carried up to form a close joint with the underside of a pitched roof of non-combustible covering or carried up above the level of such roof covering. The junctions between such separating wall and roof shall be properly fire-stopped so as not to render ineffective the resistance of such separating wall to the effects of the spread of fire.

3.6.4 External wall junction

If any external wall is carried across the end of a separating wall, such external wall and separating wall shall be bonded together or the junction of such walls shall be fire-stopped to comply with the requirements of [Cl.3.12](#).

3.6.5 Prohibition of combustible materials in separating walls

No combustible material shall be built into, carried through, or carried across the ends of or carried over the top of separating walls in such a way as to render ineffective such separating walls to the effects of the spread of fire.

CLAUSE 3.7 COMPARTMENT WALLS AND COMPARTMENT FLOORS

3.7.1 General

Every compartment wall or compartment floor shall be required to:

- a. Form a complete barrier to fire between the compartments it separates;
- b. Have the appropriate fire resistance to comply with the requirements of Cl.3.3; and
- c. Be constructed of non-combustible materials (together with any beam or column which forms part of the wall or floor and any structure which it carries).

3.7.2 Openings in compartment walls or compartment floors

A compartment wall or compartment floor shall have no openings in it, except for:

- a. A door which has the same fire resistance rating as the compartment wall and complies with the relevant requirements of Cl.3.4, unless permitted by other provisions of the Code, or
- b. A protected shaft which complies with the requirements of Cl.3.8, or
- c. The passage of a pipe or ventilation duct.

Such openings in the compartment wall or compartment floor shall be protected to comply with the relevant provisions of Cl.3.9.

3.7.3 Openings

- a. Junction with other structures

Where a compartment wall or compartment floor forms a junction with any structure comprising any other compartment wall, or any external wall, separating wall or structure enclosing a protected shaft, such structures shall be bonded together at the junctions, or the junctions shall be fire-stopped to comply with the requirements of Cl.3.12.

- b. Opening in curtain walling

The opening occurring at the junction between the edge of a structural floor and the curtain walling shall be sealed to prevent the spread of smoke and flame from the lower floor to the upper floor via the opening. Materials to be used for sealing the opening shall have the requisite fire resistance rating as the elements of structure.

3.7.4 Compartment wall - roof junctions

Where a compartment wall forms a junction with a roof, such compartment wall shall be carried up to form a close joint with the underside of the roof and shall be properly fire-stopped or shall be carried up above the level of the roof covering and the junctions between such compartment wall and roof shall be properly fire-stopped so as not to render ineffective the resistance of such compartment wall to the effects of the spread of fire.

3.7.5 Prohibition of combustible materials

No combustible material shall be built into, carried through or carried across the ends of any compartment wall or compartment floor or carried over the top of any compartment wall in such a manner as to render ineffective the resistance of such wall or floor to the effects of the spread of fire.

3.7.6 Use of fire shutter

- a. General

A fire shutter is permitted to be used as compartment wall, except for the fire compartmentation of FCC, exit staircases, firefighting staircase, smoke-free lobbies, fire lift lobbies, internal exit passageways, etc. The station shall be separated from the non-transit occupancy by fire-rated shutters having at least 2 hrs fire resistance.

- b. Fire resistance

The fire shutters, which are used to protect opening in compartment wall/ floor, shall have the necessary fire resistance including thermal insulation, not less than that of the compartment wall/ floor. However, fire shutters, which are installed at the edge of atria, voids such as escalator void areas and between floors, and door-way, need not have thermal insulation.

- c. Operation

Shutters such as vertical, horizontal, and lateral fire shutters shall comply with SS 489 and the following:

- (1) Vertical fire shutter operated by gravity during a fire

Upon activation, the operating mechanism of curtains/ leaves of the vertical fire shutter shall be released. The curtain/ leaves shall descend under gravity at a controlled rate.

- (2) Electrically-operated vertical, lateral and horizontal fire shutter (fusible link is not required)

Upon activation, the electrical motor shall drive the curtains/ leaves to descend and shall be backed up by emergency power supply. The power and signal cables shall be fire-rated

- (3) Activation time and closing speed

(a) For vertical fire shutter with height not exceeding 6m, the maximum time for full closure of the fire shutter shall not exceed 30 secs from time of activation, with a descending speed not exceeding 0.2m/sec.

(b) For vertical fire shutter with height exceeding 6m and not more than 12m, the maximum time of full closure of the fire shutter shall not exceed 60 secs from time of activation, with a descending speed not exceeding 0.2m/sec.

- d. Mode of activation

The mode of activation for fire shutters at different locations shall be as follows:

- (1) Fire shutters as separating wall between station and non-transit occupancy

The localised smoke detector shall be provided on both sides of the fire rated shutter. The fire-rated shutters shall be activated by the:

- (a) Localised smoke detector(s) on either side (i.e. one side) of these fire shutters, or
- (b) Adjacent building fire alarm zone(s) in adjacent building.

Upon activation of the localised standalone smoke detector, an alarm signal shall be sent to the fire alarm panels of both the station & the adjacent building.

Where fire-rated shutters are provided, the fire-rated shutters after closing shall remain closed and be rendered inoperative until the alarm has been reset. This alarm signal is not to be used to trigger the station's or building's fire alarm and only to provide the status that the shutter is activated. The fire-rated shutters can be re-open after the fire alarm signal has been reset.

- (2) Fire shutters as compartment wall/ floor for limiting compartment area and cubical extent

Fire shutters as compartment wall/ floor for limiting compartment areas and cubical extent, as compartment between different purpose groups, as compartment of special rooms such as kitchen, electrical room, store room, etc. and as compartment of basement passenger/ goods lift lobby:

- (a) For gravity-operated vertical fire shutters, activation by fusible link is acceptable.
- (b) For electrically-operated fire shutters, activation shall be by local smoke detectors.

- (3) Fire shutters as compartmentation at atrium/ voids or between floors (being part of the engineered smoke control design)

Only electrically-operated fire shutters are permitted. The signal to operate the respective fire shutter shall be from a dedicated smoke detector installed at the respective smoke zone.

3.7.7 Fire safety signage for fire shutter and smoke curtain

Rationale

The additional exit directional signage on the fire shutter/ smoke curtain is to guide occupants to the nearest exits as the lowered fire shutter/ smoke curtain may block the station exit and/ or directional signs during a fire emergency.

a. Exit directional signage marked with an arrow and the word "EXIT" shall be prominently painted/ pasted on fire shutters/ smoke curtains to redirect station occupants to the nearest exits if the activated shutters visually obscure the station exit and/ or directional signs. The sign shall be reflective and the letters at least 100mm in height.

b. Signage for alerting persons not to impede the operation of fire shutters/ smoke curtains shall be permanently displayed at prominent locations and suitable intervals close to the descending paths of the fire shutters/ smoke curtains. The lettering of the sign shall be at least 25mm high in a colour contrasting with the background and states the following where applicable:

- (1) "FIRE SHUTTER – KEEP CLEAR"
- (2) "SMOKE CURTAIN – KEEP CLEAR"

CLAUSE 3.8 PROTECTED SHAFTS

3.8.1 Purpose of protected shaft

A protected shaft shall not be used for any purpose additional to those given as defined under [Cl.1.4.67](#). All services such as, pipe/ duct installation shall not be located inside a protected staircase, unless otherwise permitted in [Cl.3.8.7](#). Likewise, no washroom is allowed to be located inside protected staircase.

Explanation and Illustrations

The purposes of providing protected shaft are to delay or prevent the spread of fire between compartments through which staircases or other shafts pass directly and to enable people, services or air to pass between compartments. The purpose of each shaft is as follows:

- (a) Staircase shaft is a vertical shaft which enable the passage of movements of people.
- (b) Service shaft enables the passage of cable, building service ducts/ pipes.
- (c) Lift shaft enables the movements of lift cars.
- (d) Vent/ air shaft enables the movement of air.

“Protected shafts” include staircases, lift shafts, ducts, vent shafts or any other shafts enabling movement of people, goods, air, pipes, etc. Protecting structures shall be treated as elements of structure for the purpose of determining the period of fire resistance rating.

3.8.2 Requirements of protected shaft

Every protected shaft shall be required to:

- a. Form a complete barrier to fire between the different compartments which the shaft connects, and
- b. Have the appropriate fire resistance to comply with the requirements of [Cl.3.3](#), and
- c. Be constructed of non-combustible material (together with any beam or column which forms part of the enclosure and any structure which carries it).

3.8.3 Openings in protected shaft

a. A protected shaft shall have no openings in its enclosure, except:

- (1) In the case of any part of the enclosure which is formed by a separating wall, any opening which complies with the requirements of [Cl.3.6](#) for separating walls, or
- (2) In the case of any part of the enclosure which is formed by a compartment wall or a compartment floor, any opening which complies with the requirements of [Cl.3.7](#) for compartment wall or compartment floor, or
- (3) In the case of any part of the enclosure which is formed by the protecting structure:
 - (a) a door which has the appropriate fire resistance to comply with the requirements of [Cl.3.4](#) for test of fire resistance, or otherwise permitted by provision of [Cl.3.8.6](#), or
 - (b) the passage of a pipe, or
 - (c) inlets to and outlets from and opening for the duct if the shaft contains or serves as a ventilation duct.

b. Such openings in the protected shaft shall be protected to comply with the relevant provisions of [Cl.3.9](#) for protection of openings.

3.8.4 Non-combustibility of protecting structures

Every protecting structure shall be constructed wholly of non-combustible materials.

3.8.5 Ventilation of protected shaft

A protected shaft used for the passage of people, such as exit staircases, shall be ventilated to comply with the relevant provisions of the Code.

3.8.6 Doors in protecting structures

- a. Any door fitted to an opening in protecting structure shall have fire resistance for not less than half the period required by other provisions of the Code for the protecting structure surrounding the opening.
- b. Any door fitted to an opening in protecting structure of a shaft containing services, such as electrical and telecommunication cables, pipes (including gas pipe in separate shaft), ducts etc., is not required to comply with the requirements in [Cl.2.2.17e.\(2\)](#) if it is fitted with a self-closing device. Rising mains and hose reel doors shall not be fitted with self-closing device and shall comply with the stipulated corridor width when the door is in its fully opened position. Areas within the swing paths of the rising mains and hose reel doors shall be clear of any obstruction/ storage at all times.
- c. Exception

Any door fitted to an opening in protecting structure of a shaft containing services such as electrical cables, pipes (including gas pipe in separate shaft), ducts, etc., is not required to have the fire resistance rating if the door is located along the wall facing the external corridor.

3.8.7 Protected shaft containing exit staircase

A protected shaft which contains an exit staircase shall comply with the following:

- a. It shall not contain any pipe conveying gas or combustible liquid.
- b. It shall not contain any services that are not solely serving the same exit staircase except for:
 - (1) Sprinkler pipe, rising mains, hose reel pipe, fire alarm system cable in metal conduit, metal water supply pipe not exceeding 50mm in diameter and water tap; and
 - (2) UPVC or cast iron rain water down-pipes serving the roof directly above the exit staircase, and not routed through anywhere outside the staircase.
 - (3) Telecommunication cables, e.g. leaky coaxial cables (LCX) and one-way emergency voice communication system cables.
- c. The protecting structure shall be constructed of masonry or drywall. If drywall construction is used, all of the following conditions shall be complied with:
 - (1) The drywall shall be non-combustible.
 - (2) The drywall shall have the requisite fire resistance rating at least equal to that of elements of structure;
 - (3) The drywall shall in terms of impact & deflection performance to meet the partition grade under BS 9999 (Test for partitions) in accordance with BS 5234-2;
 - (4) The drywall shall meet the criteria, in terms of water absorption and bending strength performance, when subject to test of BS 1230 Part 1 (for gypsum plaster board) or ISO 1896 (for calcium silicate or cement board); and
 - (5) The station shall have at least two independent exit staircase shafts (scissors exit staircases are considered single shaft).

3.8.8 Lift shaft

A protected shaft which contains a lift shall comply with the following:

- a. It shall not contain any pipe conveying gas or combustible liquid, other than those in the mechanism of a hydraulic lift.
- b. The protecting structure shall be constructed of masonry or drywall. If drywall construction is used, the following conditions stipulated under [Cl.3.8.7c.\(1\) to \(4\)](#) shall be complied with. The drywall shall also meet the criteria of cyclic loading and dynamic test as specified under [Cl.3.3](#) of National Construction Code of Australia C 1.8.
- c. The lift shall be considered as not enclosed within a protected shaft where a lift is:
 - (1) located at the edge of atrium floors, or
 - (2) at the external wall and outside the station, or
 - (3) located in the public area which serves not more than three storeys within the same compartment.
- d. The protected shaft shall be vented in accordance with SS 550. The vents shall be so arranged as to induce exhaust ventilation of the shaft. Where vents could not be provided because of the location of the lift shaft, ventilation duct protected by drywall complying with [Cl.3.8.8b](#). serving as ventilation of the shaft can be provided in accordance with [Chapter 6](#).
- e. Openings for the passage of lift cables from the lift shaft into the lift motor room shall be as small as practicable.
- f. Transom panel above lift entrance shall not be considered as part of the entrance and shall therefore conform to the fire resistance requirements of the protected structure.
- g. If it serves any basement storey and not adjoining any void connecting to upper levels or any external spaces, there shall be provided a lobby enclosed by walls having fire resistance of at least 1-hr and fire door of at least ½ hour.

Exception: The requirement for lobbies shall not apply where lift is located in the public areas which serves not more than three basement storeys within the same compartment.

3.8.9 Protected shaft containing other services installations

A protected shaft used for the enclosure of services shall comply with the following:

a. The protecting structure for protected shaft containing mechanical ventilation ducts serving exit staircases, exit passageways, smoke-free, and fire lift lobbies which pass through one or more floors shall be constructed of masonry or drywall. Such shaft shall be completely compartmented from the rest of the shaft space containing other ducts or any other services installations. A protected shaft containing ducts serving other areas which pass through floor slabs can be constructed of drywall. If the protected shaft is of drywall construction, the conditions stipulated in [Cl.3.8.7c](#) shall be complied with.

b. Cavity barriers

A protected shaft used for the enclosure of electrical power services shall be interrupted at every floor level with at least ½-hr fire resistance cavity barriers. Protected shaft used for the enclosure of telecommunications services shall be interrupted by at least ½-hr fire resistance cavity barriers at vertical intervals not exceeding 15m. The cavity barriers within trunking enclosing electrical and telecommunication cables can be exempted if the following conditions are met:

- (1) the cables shall be flame retardant type complying with IEC 60332;
- (2) the floor within the shaft shall be sloped upward with an angle of at least 45° to the floor level; and
- (3) the fire doors to the protected shaft are installed with self-closing devices.

Rationale

Owing to the difficulty in fire-stopping the gaps within the trunking running through multiple floor levels within a protected shaft, this requirement was exempted provided additional fire safety requirements are complied with. These requirements include the use of flame retardant cables to reduce the possibility of fire from occurring/ spreading, sloping of the floor within the shaft upwards at an angle of at least 45° to prevent illegal storage of any combustible materials, and the provision of self-closing devices to the fire resisting doors to ensure that the doors are closed at all times to prevent fire from spreading.

c. Self-closing devices

Automatic self-closing devices are not required to be installed on fire resisting doors opening into protected shafts which are interrupted by at least ½-hr fire resistance cavity barriers at every floor level, or protected shafts containing sanitary pipes or water pipes, provided that the fire resisting doors are kept closed and locked at all times.

d. Fire resistant cables, flame retardant cables and extra low voltage telecommunication cables need not be housed in protected shafts.

CLAUSE 3.9 PROTECTION OF OPENINGS

3.9.1 Application

The provisions of this Clause are made in connection with the protection of openings permitted in elements of structure or other forms of fire resisting construction required to act as a barrier to fire and smoke.

Explanation and Illustrations

For functional purposes, openings in compartment walls, floors etc are required in stations to allow movement of people and the installation of services such as pipes, ventilation ducts. To prevent the spread of fire and smoke, such openings shall be appropriately protected.

3.9.2 Fire doors

Fire doors for protection of openings shall comply with all the following:

Explanation and Illustrations

Aligned with other clauses in this code all fire doors shall be constructed of non-combustible materials to achieve the appropriate fire resistance.

- a. Fire doors shall have the appropriate fire resistance as required by relevant parts of the Code. A two-leaf door can be fitted in an opening if each door leaf by itself is capable of closing the opening and the two-leaf door together achieve the required level of fire resistance.
- b. All fire doors shall be fitted with an automatic self-closing device which is capable of closing the door from any angle and against any latch fitted to the door except as permitted in [Cl.3.8.9c](#) and [Cl.3.9.2f](#).
- c. Fire doors held open by electromagnetic or electromechanical devices shall be activated to close by the localised smoke detector(s) on either (one) side of the fire doors.
- d. Any fire door fitted in an opening which is provided as a means of escape:
 - (1) shall be capable of being opened manually;
 - (2) shall not be held open by any means other than by an electromagnetic or electromechanical device which can be activated by the presence of smoke and/ or the fire alarm system, provided that this shall not apply in the case of fire doors opening into pressurised exit staircases; and

Explanation and Illustrations

Aligned with other clauses in this code all fire doors shall be constructed of non-combustible materials to achieve the appropriate fire resistance.

- (3) shall open in the direction of exit travel in accordance with [Cl.2.2.17d](#).
- e. Fire resisting doors where required to be provided shall be constructed and installed to comply with specifications stipulated under SS 332 for Fire Doors and SS 489 for Fire Shutters.
- f. The inactive leaf of double-leaf doors for plant/ equipment/ machine rooms and for lobby/ corridor leading to these rooms, where the inactive leaf is only for use as equipment access, need not be fitted with a self-closing device, but shall be bolted in place and fitted with a sign "Keep door bolted".

Explanation and Illustrations

Aligned with other clauses in this code all fire doors shall be constructed of non-combustible materials to achieve the appropriate fire resistance.

3.9.3 Pipes

Rationale

The exceptions are stipulated so as to cater for larger pipes such as chilled water pipes that require penetration into compartments. These exceptions however, are also subjected to accompanying conditions to minimise fire risk.

- a. Pipes passing through a separating wall, compartment wall or compartment floor shall be kept as small as possible and fire-stopped around the pipe. The nominal diameter of the pipe shall not be more than the respective dimension given in [Table 3.9A](#). These pipe penetrations are permitted only for conveying non-hazardous & non-combustible substances such as air, water, etc., and approved fire-stopping material shall be applied around the pipe penetration. Clear spacing between pipes shall be minimum 50mm or ½ diameter of the largest pipe, whichever is larger.
- b. The following pipes of nominal diameter larger than 150mm, subject to the conditions listed under subclause c. below, are permitted to penetrate through a separating wall, compartment wall or compartment floor.
 - (1) Emergency standby diesel generator steel exhaust pipes connected directly to the external;
 - (2) Pipes of non-combustible material (such as cast iron or steel) with pipe wall thickness of at least 5mm, and melting point of at least 1200°C; and
 - (3) Thermal insulated pipes with pipe wall thickness of at least 5mm and combustible insulation in compliance with [Cl.7.1.3a](#). The metal sheath for insulation material shall be at least 0.6mm thick galvanised steel with the melting point, including pipe support, of at least 1200°C.
- c. The following conditions shall be complied with for penetration of pipes stipulated under subclause b.:
 - (1) For non-sprinkler-protected area, pipe supports within 3m from the pipe penetration shall be strengthened such that the tensile stress generated on the supports shall not exceed 10N/mm² and will not be softened or fracture when exposed to temperature of 750°C. For sprinkler-protected area, the pipe supports and pipe penetrations shall be protected by the sprinkler system;
 - (2) Combustible materials or services (e.g. pipe or ductwork) are not permitted to be placed within 1m before and after the penetration (except for those thermal insulated pipes constructed under the sub-clause b.(3)). For the purpose of this sub-clause, fire-rated materials are deemed as non-combustible; and
 - (3) The penetration shall not pass through fire-rated wall/ floor of exit staircase, firefighting staircase, fire lift lobby, smoke-free lobby, electrical switch room, transformer room, generator room, battery room and fan room serving fire protection system, fire pump room, FCC, fuel tank room, and areas handling hazardous materials. Except for exit staircase, the penetration of pipes through the abovementioned rooms/ spaces is permitted if the pipes are fully enclosed by fire-rated enclosure with the same fire-rating as these fire-rated walls/ floors.
- d. In addition to sub-clause a. fuel and vent pipes for emergency standby diesel generators and fuel tanks located outside the room they served shall be enclosed in construction having fire resistance of at least 2 hrs. They shall not be located in intake/ fresh air vent shaft.

3.9.4 Ventilation ducts

Ventilation duct which passes directly through a compartment wall or compartment floor shall comply with the following:

- a. Where the ventilation duct does not form a protected shaft or is not contained within a protecting structure,
 - (1) the duct shall be fitted with a fire damper where it passes through the compartment wall or compartment floor; and
 - (2) the opening for the duct shall be kept as small as practicable and any gap around the fire damper shall be fire-stopped.
- b. Where the ventilation duct forms a protected shaft or is contained within a protecting structure, the duct shall be:
 - (1) fitted with fire dampers at the inlets to the shaft and outlets from it; and
 - (2) constructed and lined with materials in accordance with the requirements in [Chapter 7](#).
- c. The installation of ventilation ducts and fire dampers shall comply with the requirements in [Chapter 7](#).

3.9.5 Flues

Duct encasing one or more flue pipes which passes through a compartment wall or compartment floor shall be of non-combustible construction having fire resistance of not less than half the minimum period of fire resistance required for the compartment wall or compartment floor through which it passes.

3.9.6 Service pipings and ductings

Air ducts and other services that are likely to permit the passage of flame or smoke in the event of a fire shall not be permitted to pass through any of the following rooms:

- a. FCCs.
- b. Fire pump rooms.
- c. Emergency generator rooms.
- d. Smoke control fan rooms.

except where such services are required for the operation of these equipment in these areas.

3.9.7 CD blast door

a. Where a CD blast door or CD air-tight door is installed in a fire-rated compartment wall and is to be use only during CD operational mode, it shall be kept in the closed position at all times and is deemed to be part of the fire-rated compartment. Signage shall be provided on both sides of the CD door that reads: "KEEP DOOR CLOSED DURING PEACE TIME".

b. Where a CD blast door or CD air-tight door is installed in a fire-rated compartment wall and is required to be kept in the fully opened position in accordance with [Chapter 2](#), a fire-rated door shall be provided in the doorway in accordance with the Code of Practice for Fire Precautions in Buildings to maintain the integrity of the fire-rated compartment.

3.9.8 CD blast valves

Where CD blast valves are installed in a fire-rated compartment wall, fire shutters or demountable fire-rated panels shall be provided across the CD blast valves to maintain the integrity of the fire-rated compartment walls during peace time.

CLAUSE 3.10 EXIT STAIRCASES

3.10.1 Non-combustibility of structure

Every exit staircase, including the treads/ risers and landing, shall be constructed of non-combustible materials.

3.10.2 Structure separating exit staircase

The exit staircase shall be separated from other parts of the station by a masonry structure or dry wall complying with [Cl.3.8.7c.](#) which shall have fire resistance for not less than the period required by [Cl.3.3](#) for Fire Resistance Elements of Structure.

3.10.3 Exit doors

Doors opening into the exit staircase shall have fire resistance of at least ½-hr and fitted with automatic self-closing device.

3.10.4 Finishes

Finishes to the ceilings/ walls and floors of exit staircase shall be of non-combustible materials.

CLAUSE 3.11 CONCEALED SPACES

3.11.1 General provision

Rationale

Concealed spaces or cavities in station provide a ready route or flue for smoke and flame to spread undetected, thus increasing the risk to life safety of occupants in the station. This is particularly so in the case of void spaces above a suspended ceiling or in a roof space or in a raised floor system. The cavity barriers shall be constructed of non-combustible materials and of at least ½-hr fire resistance rating so as to provide adequate protection.

Concealed spaces in a station shall be interrupted by construction of cavity barriers to restrict the spread of smoke and flames.

3.11.2 Closing the edges of cavities

Cavity barriers shall be used to close the edges of cavities, edges around openings through a wall, floor and any other part of the construction which contains a cavity and to separate any cavity in a wall, floor, or any other part of the construction from any other such cavity.

3.11.3 Interrupting cavities

Cavities shall be interrupted by cavity barriers where a wall, floor, ceiling, roof or other part of the construction about the cavity, if there is provision for the element of structure to form a fire resisting barrier. Such cavity barriers shall be of fire resisting construction at least equal to the provision for that required for the fire resisting barrier.

3.11.4 Sub-division of extensive cavities

Rationale

The reason for limiting the dimension of cavities is to minimise fire or smoke within concealed space.

Cavities, unless otherwise permitted, shall be sub-divided so that the maximum distance between cavity barriers in any direction shall not exceed 20m.

3.11.5 Fire resistance and fixing of cavity barriers

Rationale

Compartment walls shall be extended to the full height of the storey i.e. from the floor to the soffit of the ceiling slab. This will ensure a complete compartment of each unit and prevent smoke and fire spread that may occur via the concealed ceiling space.

Cavity barriers shall be:

- constructed to provide at least ½ hour fire resistance, and
- tightly fitted to rigid construction, or the junctions shall be fire stopped to comply with the requirements of [Cl.3.12](#).

Explanation and Illustrations

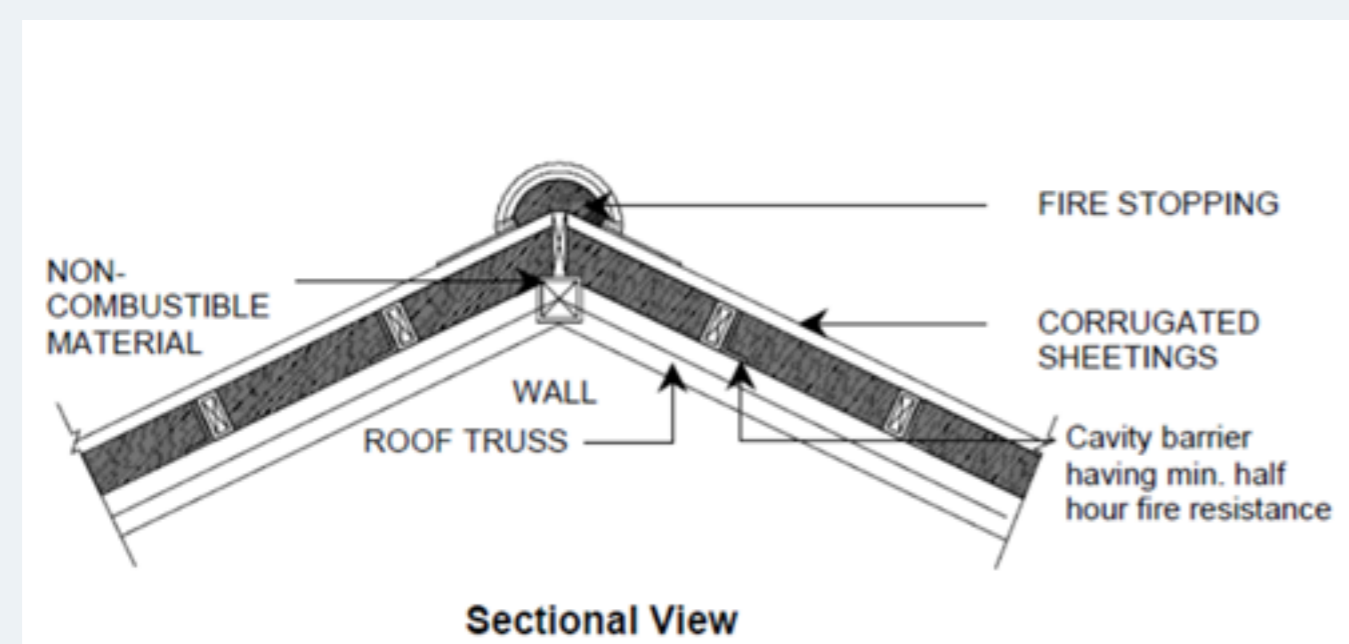

Cavity barrier must be properly secured to rigid construction and mechanically fixed in position wherever possible. Where this is not possible (for example, in the case of a junction with slates tiles, corrugated sheeting or similar materials) the junction should be fire-stopped to prevent the spread of fire and smoke in the concealed space.

Cavity barriers must also be fixed so that performance will not be made ineffective by:

- Movement of the building due to subsidence, shrinkage or temperature change;
- Collapse in fire of any services penetrating them;
- Failure of fixings in fire; and
- Failure during fire of any material or construction which they may abut in fire. For example, if a suspended ceiling is continued over the top of a fire-resisting wall or partition, and direct connection is made between the ceiling and the cavity barrier above the line of the wall or partition, premature failure of the cavity barrier can occur when the ceiling collapses. However, this does not arise if the ceiling is designed to provide fire protection of 30 minutes or more.

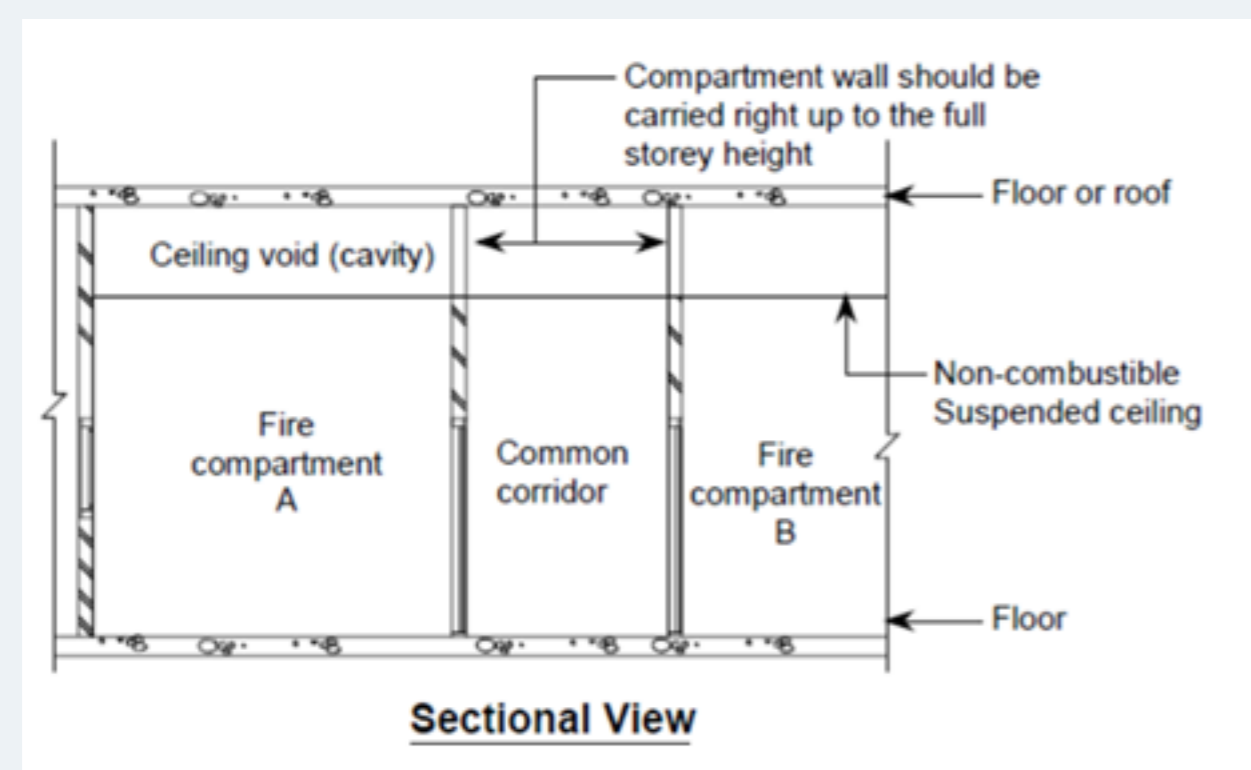

Compartment walls shall be carried right up to the full height of the storey i.e. from the structure floor to the soffit of the ceiling slab. The walls in the ceiling above common corridor shall not be treated as cavity barriers. They shall be treated as extension of the compartment below.

The main purpose of extending the compartment walls into the ceiling space is to complete the compartmentation to each unit, so as to prevent smoke and fire spread via the concealed ceiling space

3.11.6 Openings in cavity barriers

A cavity barrier shall have no opening in it except for:

- a door which has at least ½ hour fire resistance and shall be kept closed all the time, or
- a pipe which complies with the provision under [Cl.3.9.3](#), or

- c. a cable or conduit containing one or more cables, or
- d. an opening fitted with suitably mounted automatic fire damper, or
- e. a duct which is fitted with a suitably mounted automatic fire damper where it passes through the cavity barrier.

3.11.7 Raised floors with or without accessible panels

The construction of raised floors with or without accessible panels shall comply with the following requirements:

- a. The supporting structure shall be constructed of non-combustible materials having a melting point of at least 750°C.
- b. The concealed space between the structural floor and raised floor shall not be used for storage purpose.
- c. No services or installation shall be permitted within the concealed space other than;
 - (1) Electrical wiring in metal conduit and metal trunking in compliance with the requirements of SS 638;
 - (2) Communication cables for computer equipment; and
 - (3) Fire protection installations serving the area.
- d. Where the raised floor is used as a plenum, requirements in [Chapter 7](#) shall be satisfied.
- e. Decking of the raised floor shall be constructed of non-combustible material or where combustible material is used as core material, if allowed in the case of sprinkler protected areas/ compartment, the top, bottom, all sides and cut edges shall be covered with material with surface property complying with Class 0 (excluding materials for floor finishes).
- f. In the case of raised floors with accessible panels, access sections or panels shall be provided such that all concealed spaces between the structural floor and raised floor are easily accessible.
- g. Openings in the raised floor for entry of electrical cables shall be effectively closed to prevent entry of debris or other combustible material into the concealed spaces.
- h. All sides shall be properly sealed.
- i. The concealed space shall be sub-divided by cavity barriers such that the maximum unobstructed area within the concealed space do not exceed 930m².
- j. Where the concealed space is fitted with an automatic sprinkler system which complies with the requirements in [Chapter 6](#), cavity barriers are not required.
- k. The height of concealed space measured between the top of the structural floor and underside of the raised floor decking shall not exceed 400mm and shall be fitted with automatic detection system complying with requirements of SS 645; and in the case of sprinkler protected compartment, the height of concealed space can exceed 400mm if the space is fitted throughout with an automatic sprinkler system which complies with the requirements in [Chapter 6](#).

3.11.8 Suspended ceiling over protected areas

The concealed spaces of suspended ceiling over an exit passageway, smoke-free/ fire lift lobby, exit staircase, firefighting staircase, or other designated means of escape facilities, shall comply with the following:

- a. The ceiling supporting elements and the ceiling shall be constructed of non-combustible materials; and
- b. The exposed surfaces within the concealed space shall be of Class 0 surface flame spread.

3.11.9 Exemption of cavity barriers

Provision of cavity barriers within the concealed spaces of suspended ceiling is exempted if the following requirements are complied with:

- a. The concealed space are not used for storage purpose.
- b. The supporting elements shall be constructed of non-combustible material.
- c. The exposed surfaces within the concealed space is of Class 0 flame spread, (excluding surfaces of any pipe, cable, conduit or insulation of any pipe).
- d. If the concealed space does not exceed 800mm in depth or if the concealed space is fitted with:
 - (1) detectors which comply with the SS 645, or
 - (2) an automatic sprinkler system complies with SS CP 52.

CLAUSE 3.12 FIRE STOPPING

3.12.1 General provision

Rationale

Fire stopping materials will ensure the integrity of fire compartmentation by preventing separating wall, compartment wall/floor or cavity barriers from being diminished or impaired when being penetrated by services.

Openings for pipes, ducts, conduits or cables which pass through any part of an element of structure (except for a part which does not serve as a fire resisting barrier) or cavity barrier, shall be:

- a. kept as few in number as possible;
- b. kept as small as practicable; and
- c. all gaps shall be filled with fire-stopping materials.

3.12.2 Fire-stopping

Fire-stopping shall be of material having the necessary fire resistance when tested to BS 476: Part 20 or other acceptable standards.

3.12.3 Materials for fire-stopping

Suitable fire-stopping materials include:

- a. Proprietary fire-stopping and sealing systems (including those designed for service penetrations) which have been shown under test conditions to maintain the fire resistance of the wall or other element, shall be in accordance with the Code of Practice for Fire Precautions in Buildings, except where herein modified in this Code.
- b. Other fire-stopping materials include:
 - (1) cement mortar;
 - (2) gypsum based plaster;
 - (3) cement or gypsum based vermiculite/ perlite mixes;
 - (4) glass fibre, crushed rock, blast furnace slag or ceramic based products (with or without resin binders); and
 - (5) intumescent mastics.

The method of fire-stopping and choice of materials shall be appropriate to the situation and its application.

CLAUSE 3.13 RESTRICTION OF SPREAD OF FLAME OVER SURFACES OF WALLS AND CEILINGS

3.13.1 Requirements for Class 0

Any reference to a surface being Class 0 shall be construed as a requirement that:

- a. the material of which the wall or ceiling is constructed shall be non-combustible throughout, or
- b. The surface material (or, if it is bonded throughout to a substrate, the surface material in conjunction with the substrate) shall have a surface of Class 1 when tested to BS 476: Part 7 and if tested in accordance with BS 476: Part 6 shall have an index of performance (I) not exceeding 12 and a sub-index (i1) not exceeding 6.

3.13.2 Requirements for a class other than Class 0 classification

Rationale

BS 476: Part 7 refers to a standard fire test for the classification of the surface spread of flame of products. This test is able to determine the tendency of surfaces of flat material to support the spread of flame across their surfaces and specifies a method of classification appropriate to wall and ceiling linings. Class 0 represents the best performance, followed in ascending order by Class 1, Class 2, Class 3 and Class 4. This clause is rephrased for clarity.

Any reference to a surface being of a class other than Class 0 shall be taken as complying with the relevant test criteria as to surface spread of flame specified in relation to that class in BS 476: Part 7.

3.13.3 Classification

Rationale

The reason of having Class 0 standard is that Class 1 standard covers too wide a range of performance for use in critical areas. Where a higher degree of protection is required, Class 0 standard is necessary.

Class 0 shall be regarded as the highest class followed by Class 1 as set hereunder:

- a. Class 0 – Surface of no flame spread. Such surfaces shall conform to the requirements of [Cl.3.13.1](#).
- b. Class 1 – Surface of very low flame spread. This refers to surfaces on which during the first 1½ mins of test, the spread of flame does not exceed 165mm and the final spread of flame does not exceed 165mm under the relevant test conditions.

CLAUSE 3.14 ROOFS

3.14.1 Roof construction

- a. The surface of materials for roof covering and roof construction shall have a surface spread of flame rating not lower than BS Class 1, or Class A when tested in accordance with ASTM E108.
- b. Composite panel used as roof covering shall comply with the relevant clauses of the Code of Practice for Fire Precautions in Buildings.
- c. Roof covering containing plastic shall comply with the relevant clauses of the Code of Practice for Fire Precautions in Buildings.

3.14.2 Roof junction with separating wall and compartment wall

At the junctions with separating wall or compartment wall, roof construction shall comply with the relevant requirements under [Cl.3.6.3](#) and [Cl.3.7.4](#) respectively.

CLAUSE 3.15 MATERIALS FOR CONSTRUCTION

3.15.1 General

Materials used in the construction of station elements shall comply with the provisions stated under this Chapter in addition to the performance requirements such as for fire resistance stipulated in other relevant Chapters.

3.15.2 Intumescent paint

Rationale

Intumescent paint is permissible for use as a passive fire protection system on structural steel. It is not applicable to industrial buildings as these buildings may contain harsh and/or adverse environment conditions that could affect the effective performance of intumescent paint applied on the structural steel.

Intumescent paint is allowed to be used for protection of structural steel members of all stations provided all of the following requirements are complied with:

- a. The paint shall be of a proprietary system that has been demonstrated to achieve the fire resistance performance as required in BS 476: Part 20/ 21 or its equivalent, together with the specified weathering tests as specified in the BS 8202: Part 2.
- b. Coating of intumescent paint onto structural steels, and subsequent maintenance shall conform to BS 8202: Part 2. Fire test for fire resistance performance shall be conducted on the specimens after the weather tests. The fire resistance rating of the tested specimen shall not diminish more than 25%, post-weathering tests.
- c. A signage depicting the below minimum information shall be affixed at a conspicuous location:
 - (1) Name of supplier
 - (2) Fire resistance rating of the intumescent paint
 - (3) Date of painting
 - (4) Expected date of re-painting
 - (5) Caution note: "Caution – No other paint/ coating shall be applied to the surfaces of the structural steel members protected by the intumescent paint system"

3.15.3 Flame retardant chemicals

Rationale

The main concerns for not accepting flame retardant chemicals are:

- a. The performance of the flame retardant chemicals in combustible materials may deteriorate over time;
- b. The flame retardant chemicals are toxic elements, which when subjected to fire, would produce large quantities of toxic gases.

Flame retardant chemicals, intended for upgrading of fire resistance rating of any combustible material, shall not be allowed to improve the required fire resistance.

3.15.4 Elements of structure

All elements of structure shall be constructed of non-combustible materials in addition to the relevant provisions as follows:

- a. [Cl.3.3](#) for fire resistance of elements of structure
- b. [Cl.3.5.1](#) & [Cl.3.5.3](#) for external walls,
- c. [Cl.3.6.1](#) & [Cl.3.6.5](#) for separating walls,
- d. [Cl.3.7.1](#) & [Cl.3.7.5](#) for compartment walls and compartment floors,
- e. [Cl.3.8.2](#), [Cl.3.8.2](#), [Cl.3.8.4](#), [Cl.3.8.7c](#), [Cl.3.8.8](#), & [Cl.3.8.9a](#) for protected shafts.

3.15.5 Protection of openings

Materials used for the protection of openings shall comply with the relevant provisions of [Cl.3.9](#) of this Code for protection of openings.

3.15.6 Exit staircases

Exit staircases shall be constructed of non-combustible materials to comply with the provisions of [Cl.3.10.1](#)

3.15.7 Raised floors

Materials used for the construction of raised floors shall comply with the provisions of [Cl.3.11.7a](#) and [Cl.3.11.7e](#).

3.15.8 Ceiling supports

Materials used for construction of ceiling supports shall comply with the provisions of [Cl.3.11.8a](#).

3.15.9 Fire stopping

Materials used for fire stopping shall comply with the relevant provisions of [Cl.3.12.2](#) and [Cl.3.12.3](#).

3.15.10 Roofs

Materials used for roof construction shall comply with the provisions of [Cl.3.14.1](#).

3.15.11 Non-load bearing walls, partitions, claddings/ wall panels, false ceilings, balustrades and railings

Internal non-load bearing walls, partitions, claddings/ wall panels, false ceiling, balustrades, and railings in stations, including the materials for surface finishes, shall be constructed of non-combustible materials.

Exception: Wall finishes in the form of thin sheets of at most 1mm thickness mounted on non-combustible substrate in commercial space where sprinkler protection is provided.

3.15.12 Materials containing plastics

Rationale

The main concern is the combustible core of the panels, which could readily ignite and hasten fire spread.

Composite panels and sandwich panels which has non-combustible covering but consist of plastic or combustible core are prohibited.

3.15.13 PVC pipes

PVC pipes are prohibited in underground stations, except for:

- a. Encased PVC pipes in concrete;
- b. PVC pipe sleeves in structure; and
- c. Condensate drain pipes for air-conditioning units.

3.15.14 Fire-rated glass

Fire-rated glass if used as walls and doors for fire compartmentation of shops, shall comply with the following:

- a. the walls and doors shall have the necessary fire resistance, including insulation, when subject to test under BS 476: Part 20-23; and
- b. the walls and doors shall meet the requirement of Class A for Impact Performance when tested under BS 6206 and EN 12600 or AS 2208.

3.15.15 Walls finishes

Use of plastic materials as vertical screening/ divider of telecommunication equipment at non-habitable open-to-sky roof is permitted, provided the materials meet at least Class 2 rating classified under *BS 476: Part 7* or equivalent.

CLAUSE 3.16 USE OF PLASTIC MATERIAL

Use of plastic material shall be in accordance with the Code of Practice for Fire Precautions in Buildings, except where herein modified in this Code.

Diagram 3.2.4c.: Compartmentation of Commercial Spaces

Compartmentation of additional commercial spaces made up of a group of shops

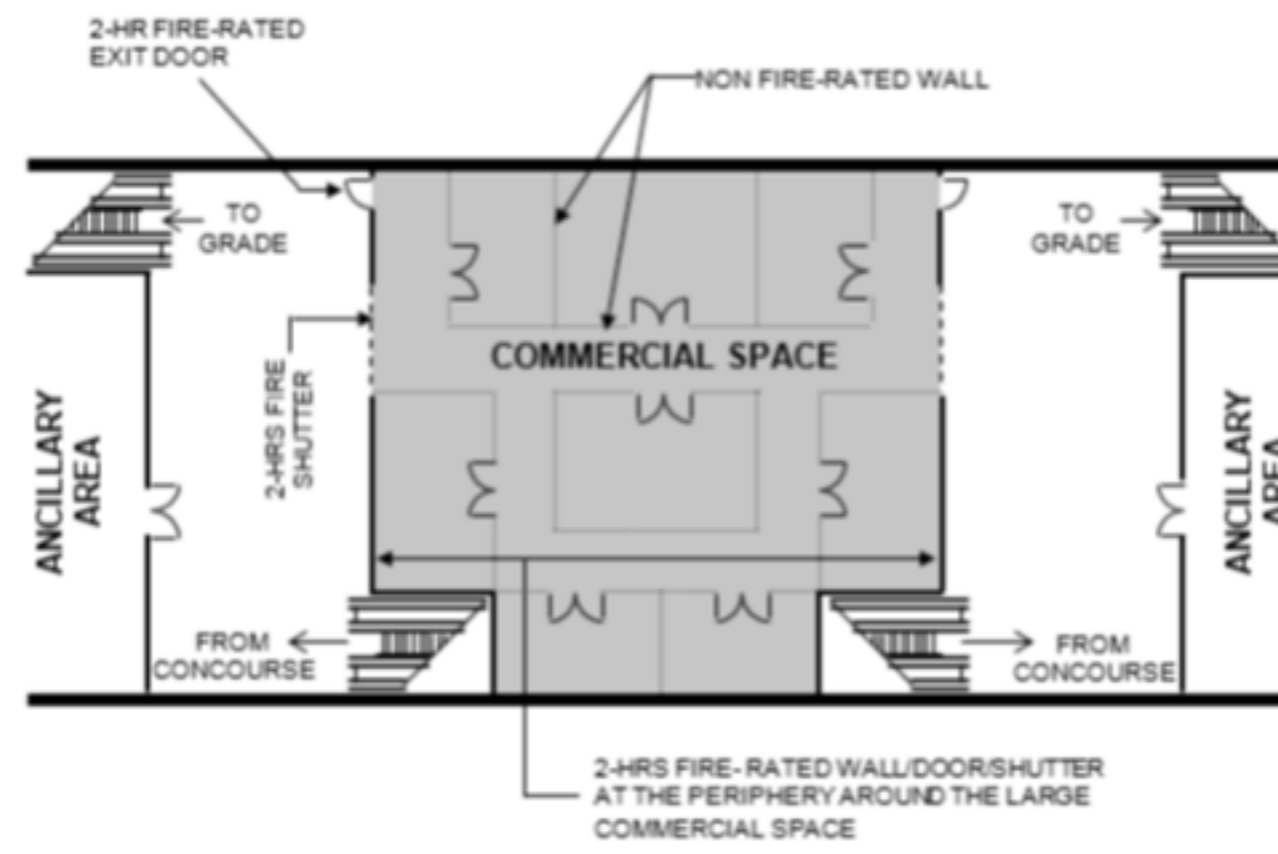

Compartmentation of commercial spaces at the ground level of station entrance

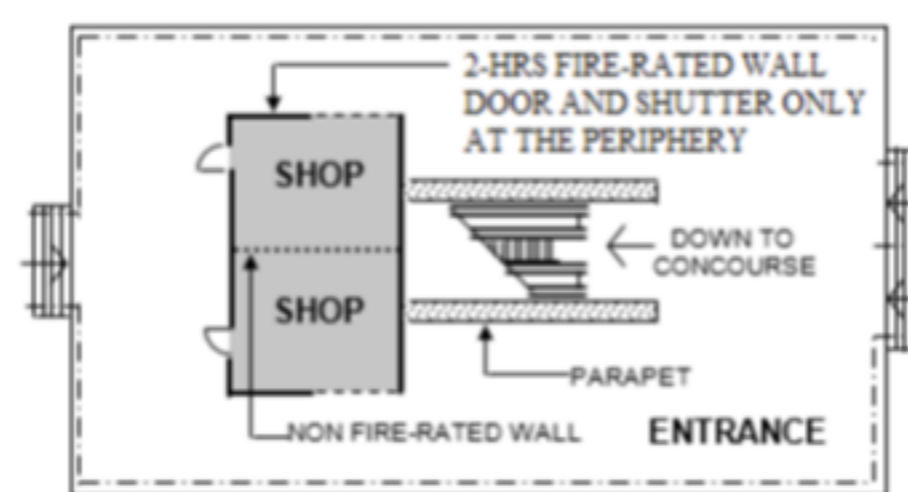
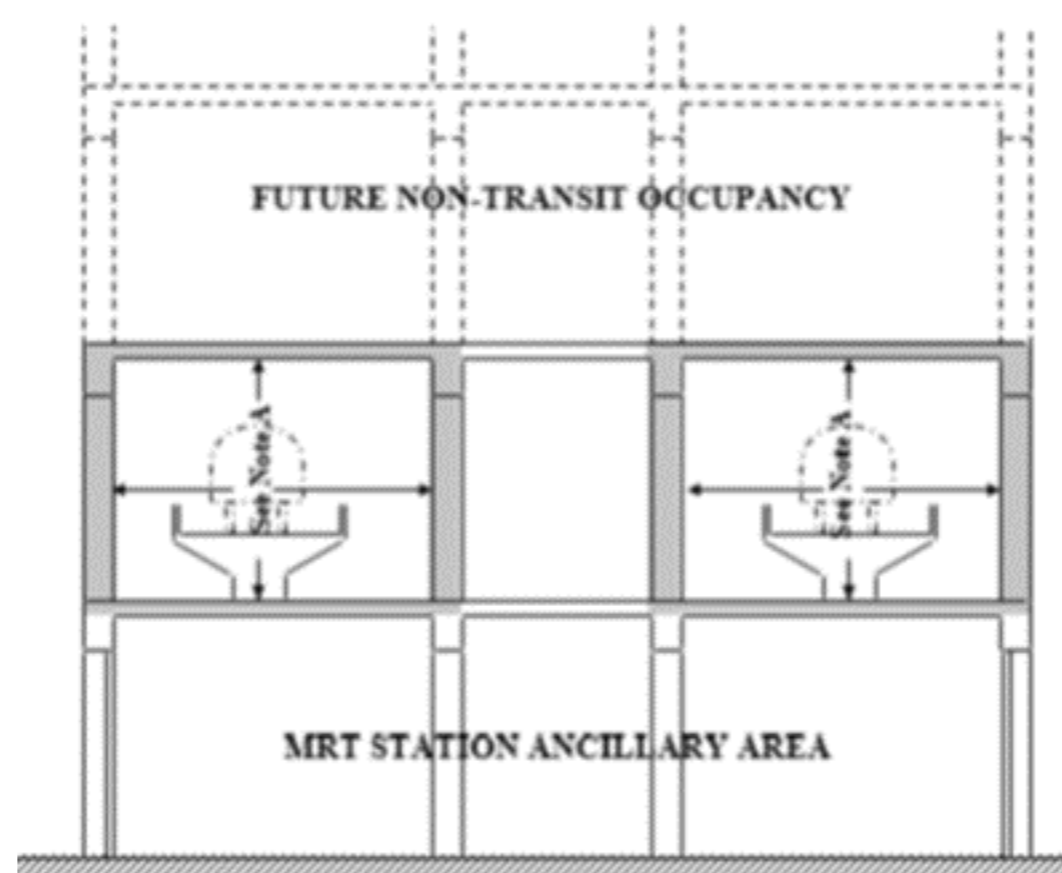

Diagram 3.2.4c.: Compartmentation of Commercial Spaces

Diagram 3.3.2c.: Cross-Section of Trainway



Fire resistance of elements of structure around the trainway in an aboveground station where there are habitable floors directly above the trainway.

Note: All elements of structure shall not be less than 4 hrs fire rating.

Diagram 3.3.2c.: Cross-Section of Trainway

Diagram 3.5.2d.: Distance between Existing Building and New Station Entrance

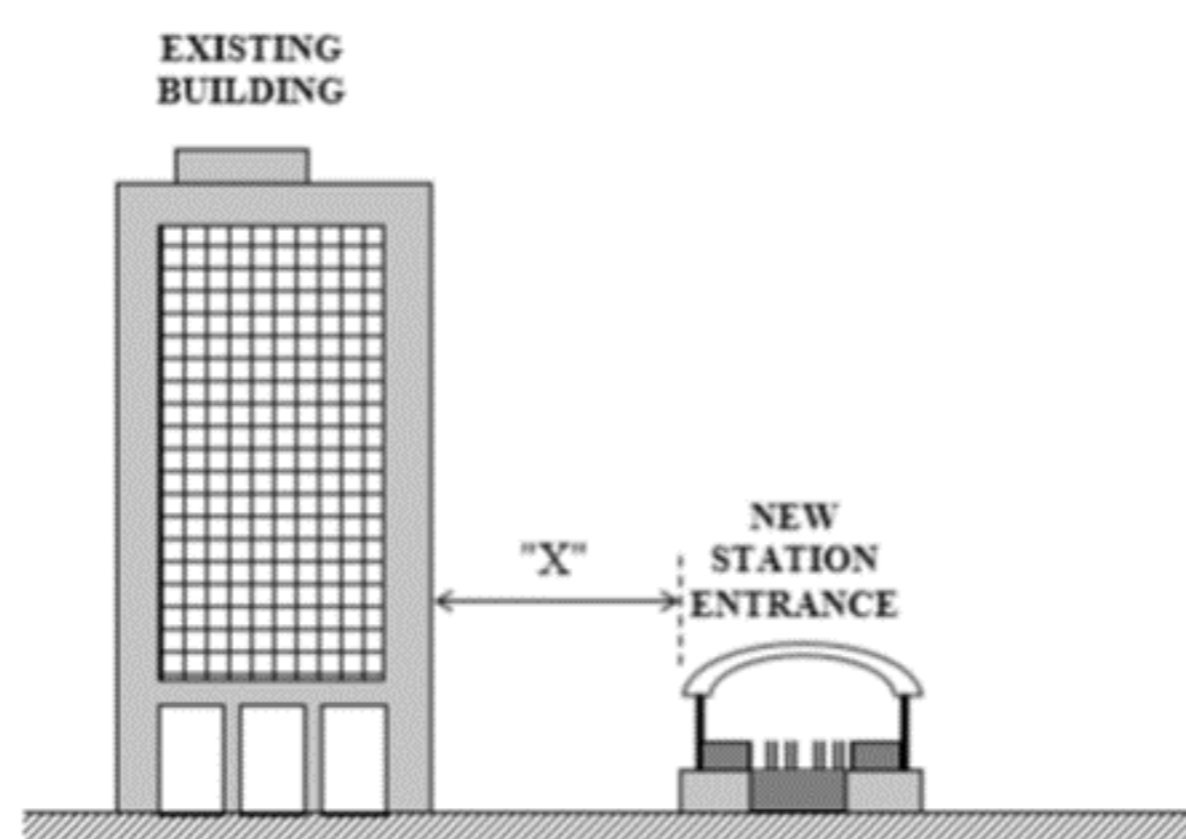

Separation distance "X" between the external wall of a ground level entrance (with no habitable room) and the external wall of an adjacent building.

Diagram 3.5.2d.: Distance between Existing Building and New Station Entrance

TABLE 3.2A: SIZE LIMITATION OF STATION AND COMPARTMENT

TABLE 3.2A: SIZE LIMITATION OF STATION AND COMPARTMENT		
Compartments	Maximum Floor Area	Maximum Cubical Extent
	(2)	(3)
Compartment below ground level. No compartment to comprise more than one storey*.	2000m ²	7500m ³
Compartments between average ground level and a height of 24m. No compartment to comprise more than 3 storeys.	4000m ²	15000m ³
Compartments above a height of 24m from average ground level. No compartment to comprise more than one storey.	2000m ²	7500m ³

Note:
* = Size limitation of compartment below ground level is not applicable to the public area. Public area below ground level shall comply with Cl.3.2.4e.

TABLE 3.4A: SPECIFIC PROVISIONS OF TEST FOR FIRE RESISTANCE OF ELEMENTS OF STRUCTURE ETC

TABLE 3.4A: SPECIFIC PROVISIONS OF TEST FOR FIRE RESISTANCE OF ELEMENTS OF STRUCTURE ETC

Part of station	Minimum provisions when tested to BS 476: Part 20-23 (mins)			Method of exposure
	Stability	Integrity	Insulation	
1. Structural frame, beam, or column	*	no requirement	no requirement	exposed faces
2. Loadbearing wall, which is not also an external wall, separating wall, compartment wall or protecting structure (See 4, 5, 6 or 7)	*	no requirement	no requirement	each side separately
3. Floors	*	*	*	from underside
4. External walls (a) any part less than 1m from point of relevant boundary	*	*	*	each side separately from inside
(b) any part 1m or more from the relevant boundary	*	*	*	
5. Separating wall	*	*	*	each side separately
6. Compartment wall	*	*	*	each side separately
7. Protecting structure any part	*	*	*	each side separately
8. Doors (a) in a separating wall	no provision	+	no provision	each side separately when fitted in its frame
(b) in a compartment wall	no provision	+	no provision	
(c) in a protecting structure	no provision	**	no provision	
(d) any other door (including a door in a cavity barrier)	no provision	30	no provision	
9. Cavity barrier (a) cavity barrier 1m x 1m or larger	30	30	15	each side separately
(b) any other cavity barrier	30	30	no provision	
(c) ceiling	30	30	30	from underside

Note:
 * - Period of fire resistance as specified.
 ** - Half the period of fire resistance for the wall or floor in which the door is situated.
 + - Period of fire resistance for the wall or floor in which the door is situated.

TABLE 3.9A: MAXIMUM NOMINAL DIAMETER OF PIPES

Situation	Pipe material and maximum nominal diameter [mm]		
	Non-combustible Material(1)	Lead, aluminium, or aluminium alloy or UPVC(2)	Any other material
When the pipes (include pipe supports) penetrate the structure enclosing a protected shaft which is not an exit stairway or lift shaft	150	100(5)	40(5)
Any other situation	150	100 (stack pipe)(3),(4),(5)	40(5)
		75 (stack pipe)(3),(4),(5)	

Note:
 (1) A non-combustible material (such as for cast iron or steel pipes and the pipe supports with melting point of at least 1200°C) which if exposed to a temperature of 750°C will not soften nor fracture to the extent that flame or gases will pass through the wall of the pipe.
 (2) Unplasticised Poly Vinyl Chloride (UPVC) pipes shall comply with BS 4514 or EN 1329-1. Use of PVC pipes shall comply with Cl.3.15.1.
 (3) Within toilets, wash rooms or external corridors, maximum diameter of UPVC pipes can be increased to double the size given in the above table.
 (4) Within areas of fire risk and adjacent to escape routes, UPVC pipes shall be enclosed by construction having fire resistance of at least ½-hr.
 (5) Where the size of UPVC pipes exceeds that specified under this clause, approved fire collar shall be fitted at all positions where such pipes pass through constructions required to act as a barrier to fire spread.

ANNEX 3A - NOTIONAL PERIODS OF FIRE RESISTANCE

A.1 GENERAL

A.1.1 In this Annex:

a. 'Class 1 aggregate' means foamed slag, pumice, blast furnace slag, pelleted fly ash, crushed brick and burnt clay products (including expanded clay) well-burnt clinker and crushed limestone. 'Class 2 aggregate' means flint gravel, granite, and all crushed natural stones other than limestones.

b. Any reference to plaster means:

- (1) In the case of an external wall 1m or more from the relevant boundary, plaster applied on the internal face only;
- (2) In the case of any other wall, plaster applied on both faces;
- (3) If to plaster of a given thickness on the external face of a wall, except in the case of a reference to vermiculite-gypsum plaster, rendering on the external face of the same thickness; and
- (4) If to vermiculite-gypsum plaster, vermiculite-gypsum plaster of a mix within the range of 1½ to 2:1 by volume.

c. In the case of a cavity wall, the load is assumed to be on inner leaf only except for fire resistance period of 4 hrs.

d. Any material or type of construction or method of mixing, preparing, using, applying or fixing the material as referred to in the table, shall conform with the relevant provisions of the Building Control Act (Chapter 29), and the relevant Singapore Standard or Singapore Standard Code of Practice. In the absence of the aforementioned Standard or Code of Practice, the relevant British equivalent or other accepted Standard or Code of Practice shall be applicable.

A.2 WALLS

A.2.1 Masonry construction:

Construction and materials	Minimum thickness excluding plaster (in mm) for period of fire resistance of					
	Loadbearing			Non-loadbearing		
	4-hrs	2-hrs	1-hrs	4-hrs	2-hrs	1-hrs
1. Reinforced concrete, minimum concrete cover to main reinforcement of 25 mm:						
(a) Unplastered (to comply with SS EN 1992-1-2)	-	-	-	-	-	-
(b) 12.5mm cement-sand plaster	180	100	75	-	-	-
(c) 12.5mm gypsum-sand plaster	180	100	75	-	-	-
(d) 12.5mm vermiculite-gypsum plaster	125	75	63	-	-	-
2. No-fines concrete of Class 2 aggregate:						
(a) 13mm cement-sand plaster	-	-	-	150	150	150
(b) 13mm gypsum-sand plaster	-	-	-	150	150	150
(c) 13mm vermiculite-gypsum plaster	-	-	-	150	150	150
3. Bricks of clay, concrete, or sand - lime:						
(a) Unplastered	200	100	100	170	100	75
(b) 13mm cement-sand plaster	200	100	100	170	100	75
(c) 13mm gypsum-sand plaster	200	100	100	170	100	75
(d) 13mm vermiculite-gypsum or perlite-gypsum plaster	100	100	100	170	100	75
4. Concrete blocks of Class 1 aggregate:						
(a) Unplastered	150	100	100	150	75	75
(b) 12.5mm cement-sand plaster	150	100	100	100	75	75
(c) 12.5mm gypsum-sand plaster	150	100	100	100	75	75
(d) 12.5mm vermiculite-gypsum plaster	100	100	100	75	75	50
5. Concrete blocks of Class 2 aggregate:						
(a) Unplastered	-	100	100	150	100	75
(b) 12.5mm cement-sand plaster	-	100	100	150	100	75
(c) 12.5mm gypsum-sand plaster	-	100	100	150	100	75
(d) 12.5mm vermiculite-gypsum plaster	100	100	100	100	75	75
6. Autoclaved aerated concrete blocks, density 475 - 1200 kg/m³	180	100	100	100	62	50
7. Hollow concrete blocks, one cell in wall thickness, of Class 1 aggregate:						
(a) 12.5mm cement-sand plaster	-	100	100	150	100	100
(b) 12.5mm gypsum-sand plaster	-	100	100	150	100	75
(c) 12.5mm gypsum-sand plaster	-	100	100	150	100	75
(d) 12.5mm gypsum-sand plaster	-	100	100	100	75	62
8. Hollow concrete blocks, one cell in wall thickness, of Class 2 aggregate:						
(a) Unplastered	-	-	-	150	150	125
(b) 12.5mm cement-sand plaster	-	-	-	150	150	125
(c) 12.5mm gypsum-sand plaster	-	-	-	150	150	125
(d) 12.5mm vermiculite-gypsum plaster	-	-	-	125	100	100
9. Cellular clay blocks not less than 50% solid:						
(a) 12.5mm cement-sand plaster	-	-	-	-	-	100

(b) 12.5mm gypsum-sand plaster	-	-	-	-	-	100
(c) 12.5mm vermiculite-gypsum plaster	-	-	-	200	100	100
10. Cavity wall with outer leaf of bricks or blocks of clay, composition, concrete or sand-lime, not less than 100mm thick and;						
(a) inner leaf of bricks or blocks of clay, composition, concrete or sand-lime	100	100	100	75	75	75
(b) inner leaf of solid or hollow concrete bricks or blocks of Class 1 aggregate	100	100	100	75	75	75
11. Cavity wall with outer leaf of cellular clay blocks as 9 above and inner leaf of autoclaved aerated concrete blocks, density 480-1200kg/m ³	150	100	100	75	75	75

A.2.2 Framed and composite construction (non-loadbearing)

Construction and materials		Period of fire resistance (in hours)
1.	Steel frame with external cladding of 16mm rendering on metal lathing and internal lining of autoclaved aerated concrete blocks, density 480-1120 kg/m ³ of thickness of -	
	(a) 50mm	2
	(b) 75mm	4
2.	Steel frame with external cladding of 100mm concrete blocks and internal lining of 16mm gypsum plaster on metal lathing	4
3.	Steel frame with external cladding of 16mm rendering on metal lathing and internal lining of 16mm gypsum plaster on metal lathing	1
4.	Steel frame with facings on each side of -	
	(a) metal lathing with cement-sand or gypsum plaster of thickness of 19mm	1
	(b) metal lathing with vermiculite-gypsum or perlite-gypsum of thickness of -	
	(1) 25mm	2
	(2) 12.5mm	1
	(c) 9.5mm plasterboard with vermiculite-gypsum of thickness of -	
	(1) 25mm	2
	(2) 10mm	1
	(d) 12.5mm plasterboard with gypsum plaster of thickness of 12.5mm	1
	(e) 12.5mm plasterboard with vermiculite-gypsum plaster of thickness of -	2
	(1) 25mm	2
	(2) 10mm	1
	(f) 19mm plasterboard (or two layers of 9.5mm fixed to break joint) without finish	1
	(g) 19mm plasterboard for two layers of 9.5mm with vermiculite-gypsum plaster of thickness of 16mm	2
5.	Plasterboard 9.5mm cellular core partition with 22mm vermiculite-gypsum plaster	2
6.	Plasterboard 12.5mm cellular core partition -	
	(a) 12.5mm gypsum plaster	1
	(b) 16mm vermiculite-gypsum plaster	2
7.	Plasterboard 19mm finished on both faces with 16mm gypsum plaster	1
8.	Three layers of 19mm plasterboard bonded with heat gypsum plaster	2

A.3 REINFORCED CONCRETE BEAMS

Description	Minimum dimension of concrete (in mm) to give a fire resistance in hours		
	4-hrs	2-hrs	1-hrs
1. Reinforced concrete beams without any protection	Comply with SS EN 1992-1-2		
2. As (1) with cement or gypsum plaster 15mm thick on light mesh reinforcement			
(a) average concrete cover to main reinforcement	50*	30	15
(b) beam width	250	170	85
3. As (1) with vermiculite/ gypsum plaster** 15mm thick:			
(a) average concrete cover to main reinforcement	25	15	15
(b) beam width	170	125	60
4. Light weight concrete	Comply with SS EN 1992-1-2		
Note: * - Supplementary reinforcement necessary to hold the concrete cover in position. ** - Vermiculite/ gypsum plaster shall have a mix ratio in the range of 1 ½ - 2:1 by volume.			

A.4 PRESTRESSED CONCRETE BEAMS

Description	Minimum dimension of concrete (in mm) to give a fire resistance in hours		
	4-hrs	2-hrs	1-hrs

1. Prestressed concrete beams without any protection	Comply with SS EN 1992-1-2		
2. As (1) with vermiculite concrete slabs 15mm thick, used as permanent shuttering:			
(a) average concrete cover to main reinforcement	75	45	25
(b) beam width	210	125	70
3. As (2) but with 25mm thick slabs:			
(a) average concrete cover to main reinforcement	65	35	15
(b) beam width	180	100	60
4. As (1) with 15mm thick gypsum plaster with light mesh reinforcement:			
(a) average concrete cover to main reinforcement	90*	50	30
(b) beam width	250	170	85
5. As (1) with vermiculite/ gypsum plaster** 15m thick:			
(a) average concrete cover to main reinforcement	75*	45	25
(b) beam width	170	125	60
6. As (5) but with 25mm thick coating:			
(a) average concrete cover to main reinforcement	50	30	15
(b) beam width	140	85	60
7. Prestressed lightweight concrete without any protection	Comply with SS EN 1992-1-2		
<p>Note: * - Supplementary reinforcement is necessary to hold the concrete cover in position. ** - Vermiculite/ gypsum plaster shall have a mix ratio in the range of 1 ½ - 2:1 by volume.</p>			

A.5 REINFORCED CONCRETE COLUMNS

A.5.1 All Faces Exposed

Type of construction	Minimum dimension of concrete (in mm) to give a fire resistance in hours		
	4-hrs	2-hrs	1-hrs
1. Dense concrete:			
(a) without additional protection	Comply with SS EN 1992-1-2		
(b) with cement or gypsum plaster 15mm thick on light mesh reinforcement	300	225	150
(c) with vermiculite/ gypsum plaster*	275	200	120
2. Lightweight aggregate concrete	Comply with SS EN 1992-1-2		
<p>Note: * - Vermiculite/ gypsum plaster shall have a mix ratio in the range of 1 ½ - 2:1 by volume.</p>			

A.5.2 One Face Exposed

Type of construction	Minimum dimension of concrete (in mm) to give a fire resistance in hours		
	4-hrs	2-hrs	1-hrs
1. Dense concrete:			
(a) without additional protection	Comply with SS EN 1992-1-2		
(b) with Vermiculite/ gypsum plaster* 15mm thick on exposed faces	125	75	65
<p>Note: * - Vermiculite/ gypsum plaster shall have a mix ratio in the range of 1 ½ - 2:1 by volume.</p>			

A.6 STRUCTURAL STEEL

A.6.1 Encased steel stanchions (Mass per metre not less than 45kg)

Construction and materials	Minimum thickness (in mm) of protection for a fire resistance of		
	4-hrs	2-hrs	1-hrs
A. SOLID PROTECTION*			
(unplastered)			
1. Concrete not leaner than 1:2:4 mix with natural aggregates-			
(a) concrete not assumed to be load-bearing reinforced +	50	25	25
(b) concrete assumed to be load-bearing, reinforced in accordance with BS EN 1992 and SS EN 1994	75	50	50
2. Solid bricks of clay, composition or sand-lime	100	50	50
3. Solid blocks of foamed slag or pumice concrete reinforced+ in every horizontal joint	75	50	50
4. Sprayed vermiculite-cement	-	38	19
B. HOLLOW PROTECTION++			
1. Solid bricks of clay, composition or sand-lime reinforced in every horizontal joint, unplastered			
2. Solid blocks of foamed slag or pumice concrete reinforced+ in every horizontal joint, unplastered	75	50	50

3. Metal lathing with gypsum or cement-lime plaster of thickness of -	-	38§	19
4. (a) Metal lathing with vermiculite-gypsum or perlite-gypsum plaster of thickness of	50§	19	12.5
(b) Metal lathing spaced 25mm from flanges with vermiculite-gypsum or perlite-gypsum plaster of thickness of	44	19	12.5
5. Gypsum plasterboard with 1.6mm wire binding at 100mm pitch -			
(a) 9.5mm Plasterboard with gypsum plaster of thickness of	-	-	12.5
(b) 19mm Plasterboard with gypsum plaster of thickness of	-	12.5	7
6. Gypsum plasterboard with 1.6mm wire binding at 100mm pitch -			
(a) 9.5mm plasterboard with vermiculite-gypsum plaster of thickness of	-	16	10
(b) 19mm plasterboard with vermiculite-gypsum plaster of thickness of	38§	20	10
7. Vermiculite - cement slabs of 4:1 mix reinforced with wire mesh and finished with plaster skim. Slabs of thickness of	63	25	25
<p>Note: * - Solid protection means a casing which is bedded close to the steel without intervening cavities and with all joints in that casing made full and solid. + - Reinforcement shall consist of steel binding wire not less than 2.3mm in thickness, or a steel mesh weighing not less than 0.48kg/m². In concrete protection, the spacing of that reinforcement shall not exceed 150mm in any direction. ++ - Hollow protection means that there is a void between the protective material and the steel. All hollow protection to columns shall be effectively sealed at each floor level. § - Light mesh reinforcement required 12.5mm to 19mm below surface unless special corner beads are used.</p>			

A.6.2 Encased steel beams (Mass per metre not less than 30kg)

Construction and materials	Minimum thickness (in mm) of protection for a fire resistance of		
	4-hrs	2-hrs	1-hrs
A. SOLID PROTECTION+ (unplastered) 1. Concrete not leaner than 1:2:4 mix with natural aggregates -			
(a) concrete not assumed to be load-bearing, reinforced++	75	25	25
(b) concrete assumed to be load-bearing, reinforced in accordance with BS 5950: Part 8	75	50	50
2. Sprayed vermiculite - cement	-	38	19
B. HOLLOW PROTECTION* 1. Metal lathing -			
(a) with cement-lime plaster of thickness of	-	38	19
(b) with gypsum plaster of thickness of	-	22	16
(c) with vermiculite-gypsum or perlite-gypsum plaster of thickness of	32	12.5	12.5
2. Gypsum plasterboard with 1.6mm wire binding at 100mm pitch -			
(a) 9.5mm plasterboard with gypsum plaster of thickness of	-	-	12.5
(b) 19 mm plasterboard with gypsum plaster of thickness of	-	12.5	7
3. Plasterboard with 1.6mm wire at 100m pitch -			
(a) 9.5 mm plaster nailed to wooden cradles finished with gypsum plaster of thickness of	-	-	-
(b) 9.5 mm plasterboard with vermiculite - gypsum plaster of thickness of	-	16	10
(c) 19 mm plasterboard with vermiculite-gypsum plaster of thickness of	32	10	7
(d) 19 mm plasterboard with gypsum plaster of thickness of	-	20	10
4. Vermiculite-cement slabs of 4:1 mix reinforced with wire mesh and finished with plaster skim. Slabs of thickness of	63	25	25
<p>Note: * - Hollow protection means that there is a void between the protective materials and the steel. All hollow protection to columns shall be effectively sealed at each floor level. + - Solid protection means a casing which is bedded close to the steel without intervening cavities and with all joints in that casing made full and solid. ++ - Solid protection means a casing which is bedded close to the steel without intervening cavities and with all joints in that casing made full and solid.</p>			

A.7 STRUCTURAL ALUMINIUM

A.7.1 Encased aluminium alloy stanchions and beams (Mass per metre not less than 16kg)

Construction and materials	Minimum thickness (in mm) of protection for a fire resistance of		
	4-hrs	2-hrs	1-hrs
A. SOLID PROTECTION* 1. Sprayed vermiculite-cement	-	-	44
B. HOLLOW PROTECTION+ 1. Metal lathing with vermiculite-gypsum or perlite-gypsum plaster of thickness of	-	32	16
2. Metal lathing finished with neat gypsum plaster of thickness of	-	-	19
3. Gypsum plasterboard 19 mm thick with 1.6 mm wire binding at 100 mm pitch finished with gypsum-vermiculite plaster of thickness of	-	22	10
<p>Note: * - Solid protection means a casing which is bedded close to the alloy without intervening cavities and with all joints in that casing made full and solid. + - Hollow protection means that there is a void between the protective material and the alloy. All hollow protection to columns shall be effectively sealed at each floor level.</p>			

A.8 REINFORCED CONCRETE FLOORS (DENSE CONCRETE)

Description	Minimum dimension (in mm) to give fire resistance in		
	4-hrs	2-hrs	1-hrs
Solid floor slab, ribbed floor slab, hollow core slab.	Solid floor slab, ribbed floor slab, hollow core slab.		

A.8 PRESTRESSED CONCRETE FLOORS (SILICEOUS OR CALCAREOUS AGGREGATE)

Floor Construction		Minimum dimension (in mm) to give fire resistance in		
		4-hrs	2-hrs	1-hrs
1. Solid slab	Average cover to reinforcement	65*	40	25
	Depth, overall+	150	125	100
2. Cored slabs in which the cores are circular or are higher than wide. Not less than 50 % of the gross across section of the floor shall be solid material	Average cover to reinforcement	65*	40	25
	Thickness under cores	50	40	25
	Depth, overall+	190	160	110
3. Hollow box section with one or more longitudinal cavities which are wider than high	Average cover to reinforcement	65*	40	25
	Thickness of bottom flange	65	40	25
	Depth, overall+	230	180	130
4. Ribbed floor with hollow infill blocks of clay, or inverted T-section beams with hollow infill blocks of concrete or clay. A floor in which less than 50% of the gross cross section is solid material must be provided with a 15mm plaster coating on soffit	Average cover to reinforcement	65*	40	25
	Width or rib, or beam, at soffit	125	90	70
	Depth, overall+	190	160	110
5. Upright T-section	Average bottom cover to reinforcement	100*	65*	40
	Side cover to reinforcement	100	65	40
	Least width or downstanding leg	250	150	90
	Thickness of flange+	150	125	100
6. Inverted channel sections with radius at intersection of soffits with top of leg not exceeding depth of section	Average bottom cover to reinforcement	100*	65*	40
	Side cover to reinforcement	50	35	20
	Least width or downstanding leg	125	75	45
	Thickness at crown+	150	125	100
7. Inverted channel sections or U-sections with radius at intersection of soffits with top of leg exceeding dept of section	Average bottom cover to reinforcement	100*	65*	40
	Side cover to reinforcement	50	35	20
	Least width or downstanding leg	110	70	45
	Thickness at crown+	150	125	100
Note: * - Supplementary reinforcement is necessary to hold the concrete cover in position. + - Non-combustible screeds and finishes can be included in these dimensions.				

ANNEX 3B - PERMITTED LIMITS OF UNPROTECTED AREAS

B.1 CALCULATION OF PERMITTED LIMITS OF UNPROTECTED AREAS

General rules applicable to this Annex.

B.1.1 The permitted limit of unprotected areas in any side of a station or compartment shall be calculated by reference to the requirements of B.2.

B.1.2 For the purposes of this Annex, the expression 'Unprotected area' has the meaning ascribed to it by Cl.1.4.86. but in calculating the size of unprotected areas or the permitted limit of unprotected areas, the following provisions shall apply:

- a. where any of an external wall is an unprotected area, only because it has combustible material attached to it as cladding, the area of that unprotected area shall be deemed to be half the area of such cladding;
- b. no account shall be taken of any of the following:
 - (1) an unprotected area which does not exceed 0.1m² and which is not less than 1.5 m from any other unprotected area in the same side of the station or compartment (unless that other falls within (3) below);
 - (2) one or more unprotected areas having an area (or if more than one an aggregate area) not exceeding 1m² and not less than 4 m from any other unprotected area in the same of the station or compartment (except any such area as is specified in B.1.1 above);
 - (3) an unprotected area in any part of an external wall which forms part of a protected shaft; and
 - (4) an unprotected area in the side of a station not divided into compartments, if the area is not less than 28m above any ground adjoining that side of the station.

B.2 RULES OF CALCULATION BY REFERENCE TO AN ENCLOSING RECTANGLE

B.2.1 The conditions of this Part of this Annex shall be satisfied if a station or compartment is so situated that no point on the relevant boundary is either between the relevant plane of reference and the side of the station or compartment or at a distance from the relevant plane of reference which is less than the distance specified in the Tables to this Part of this Annex, according to the purpose group of the station or compartment, the dimensions of the closing rectangle and the unprotected percentage.

B.2.2 For the purpose of this Part of this Annex.

'relevant boundary' means as defined in Cl.1.4.72 and for the purpose of this calculation is either paralleled to the side of the station under consideration or at an angle of not more than 80° with that side;

'plane of reference' means any vertical plane which touches the side or some part of the side of a station or compartment but which (however far extended) does not pass within the structure of such station or compartment (and for this purpose, any balcony, coping or similar projection shall be deemed not to be part either of that side or of the structure); and the relevant plane of reference shall in each case be taken as that most favourable in that respect to the person erecting the station;

'enclosing rectangle' means the smallest rectangle on the plane of reference which would-

- a. enclose all the outer edge of any unprotected area of the station or, if the station is divided into compartments, of the compartment (other than any of an unprotected area which is at an angle of more than 80° to the plane of reference by line perpendicular to such plane);
- b. have two horizontal sides; and
- c. have height and width falling within those listed in the Tables of this Annex.

'unprotected percentage' means the percentage of the area of the enclosing rectangle which is equal to the aggregate of the unprotected areas taken into account in calculating the enclosing rectangle and as projected on it.

TABLE 1: COMPARTMENTS OF STATION OFFICE AND PUBLIC AREA

Width of enclosing rectangle in metre	Distance in metres from relevant boundary for unprotected percentage not exceeding								
	20	30	40	50	60	70	80	90	100
Enclosing rectangle 3m high									
3	1.0	1.0	1.0	1.5	1.5	1.5	2.0	2.0	2.0
6	1.0	1.0	1.5	2.0	2.0	2.0	2.5	2.5	3.0
9	1.0	1.0	2.0	2.0	2.5	2.5	3.0	3.0	3.5
12	1.0	1.5	2.0	2.0	2.5	3.0	3.0	3.5	3.5
15	1.0	1.5	2.0	2.5	2.5	3.0	3.5	3.5	4.0
18	1.0	1.5	2.0	2.5	2.5	3.0	3.5	4.0	4.0
21	1.0	1.5	2.0	2.5	3.0	3.0	3.5	4.0	4.5
24	1.0	1.5	2.0	2.5	3.0	3.5	3.5	4.0	4.5
27	1.0	1.5	2.0	2.5	3.0	3.5	4.0	4.0	4.5
30	1.0	1.5	2.0	2.5	3.0	3.5	4.0	4.0	4.5
40	1.0	1.5	2.0	2.5	3.0	3.5	4.0	4.0	5.0
No limit	1.0	1.5	2.0	2.5	3.0	3.5	4.0	4.0	5.0
Enclosing rectangle 6m high									
3	1.0	1.0	1.5	2.0	2.0	2.0	2.5	2.5	3.0
6	1.0	1.5	2.0	2.5	3.0	3.0	3.5	4.0	4.0
9	1.0	2.0	2.5	3.0	3.5	4.0	4.5	4.5	5.0
12	1.5	2.5	3.0	3.5	4.0	4.6	5.0	5.0	5.5
15	1.5	2.5	3.0	4.0	4.5	5.0	5.5	5.5	6.0
18	1.5	2.5	3.5	4.0	4.5	5.0	5.5	6.0	6.5
21	1.5	2.5	3.5	4.0	5.0	5.5	6.0	6.5	7.0
24	1.5	2.5	3.5	4.5	5.0	5.5	6.0	7.0	7.0
27	1.5	2.5	3.5	4.5	5.0	6.0	6.5	7.0	7.5
30	1.5	2.5	3.5	4.5	5.0	6.0	6.5	7.0	8.0
40	1.5	2.5	3.5	4.5	5.5	6.5	7.0	8.0	8.5
50	1.5	2.5	3.5	4.5	5.5	6.5	7.5	8.0	9.0
60	1.5	2.5	3.5	5.0	5.5	6.5	7.5	8.5	9.5

80	1.5	2.5	3.5	5.0	6.0	7.0	7.5	8.5	9.5
100	1.5	2.5	3.5	5.0	6.0	7.0	8.0	8.5	10.0
No limit	1.5	2.5	3.5	25.0	6.0	7.0	8.0	8.5	10.0
Enclosing rectangle 9m high									
3	1.0	1.0	1.5	2.0	2.5	2.5	3.0	3.0	3.5
6	1.0	2.0	2.5	3.0	3.5	4.0	4.5	4.5	5.0
9	1.5	2.5	3.5	4.0	4.5	5.0	5.5	5.5	6.0
12	1.5	3.0	3.5	4.5	5.0	5.5	6.0	6.5	7.0
15	2.0	3.0	4.0	5.0	5.5	6.0	6.5	7.0	7.5
18	2.0	3.5	4.5	5.0	6.0	6.5	7.0	8.0	8.5
21	2.0	3.5	4.5	5.5	6.5	7.0	7.5	8.5	9.0
24	2.0	3.5	5.0	5.5	6.5	7.5	8.0	9.0	9.5
27	2.0	3.5	5.0	6.0	7.0	7.5	8.5	9.5	10.0
30	2.0	3.5	5.0	6.0	7.0	8.0	9.0	9.5	10.5
40	2.0	3.5	5.5	6.5	7.5	8.5	9.5	10.5	11.5
50	2.0	4.0	5.5	6.5	8.0	9.0	10.0	11.5	12.5
60	2.0	4.0	5.5	7.0	8.0	9.5	11.0	11.5	13.0
80	2.0	4.0	5.5	7.0	8.5	10.0	11.5	12.5	13.5
100	2.0	4.0	5.5	7.0	8.5	10.0	11.5	12.5	14.5
120	2.0	4.0	5.5	7.0	8.5	10.0	11.5	12.5	14.5
No limit	2.0	4.0	5.5	7.0	8.5	10.5	12.0	12.5	15.0
Enclosing rectangle 12m high									
3	1.0	1.5	2.0	2.0	2.5	3.0	3.0	3.5	3.5
6	1.5	2.5	3.0	3.5	4.0	4.5	5.0	5.0	5.5
9	1.5	3.0	3.5	4.5	5.0	5.5	6.0	6.5	7.0
12	1.5	3.5	4.5	5.0	6.0	6.5	7.0	7.5	8.0
15	2.5	3.5	5.0	5.5	6.5	7.0	8.0	8.5	9.0
18	2.5	4.0	5.0	6.0	7.0	7.5	8.5	9.0	10.0
21	2.5	4.0	5.5	6.5	7.5	8.5	9.0	10.0	10.5
24	2.5	4.5	6.0	7.0	8.0	8.5	9.5	10.5	11.5
27	2.5	4.5	6.0	7.0	8.0	9.0	10.5	11.0	12.0
30	2.5	4.5	6.5	7.5	8.5	9.5	10.5	11.5	12.5
40	2.5	5.0	6.5	8.0	9.5	10.5	12.0	12.0	14.0
50	2.5	5.0	7.0	8.5	10.0	11.0	13.0	14.0	15.0
60	2.5	5.0	7.0	9.0	10.5	12.0	13.5	14.5	16.0
80	2.5	5.0	7.0	9.0	11.0	13.0	14.5	16.0	17.0
100	2.5	5.0	7.5	9.5	11.5	13.5	15.0	16.5	18.0
120	2.5	5.0	7.5	9.5	11.5	13.5	15.0	17.0	18.5
No limit	2.5	5.0	7.5	9.5	12.0	14.0	15.5	17.0	19.0
Enclosing rectangle 15m high									
3	1.0	1.5	2.0	2.5	2.5	3.0	3.5	3.5	4.0
6	1.5	2.5	3.0	4.0	4.5	5.0	5.5	5.5	6.0
9	2.0	3.0	4.0	5.0	5.5	6.0	6.5	7.0	7.5
12	2.0	3.5	5.0	5.5	6.5	7.0	8.0	8.5	9.0
15	2.0	4.0	5.5	6.5	7.0	8.0	9.0	9.5	10.0
18	2.5	4.5	6.0	7.0	8.0	8.5	9.5	10.5	11.0
21	2.5	5.0	6.5	7.5	8.5	9.5	10.5	11.0	12.0
24	3.0	5.0	6.5	8.0	9.0	10.0	11.0	12.0	13.0
27	3.0	5.5	7.0	8.5	9.5	10.5	11.5	12.5	13.5
30	3.0	5.5	7.5	8.5	10.0	11.0	12.0	13.5	14.0
40	3.0	6.0	8.0	9.5	11.0	12.5	13.5	15.0	16.0
50	3.5	6.0	8.5	10.0	12.0	13.5	15.0	16.5	17.5
60	3.5	6.5	8.5	10.5	12.5	14.0	15.5	17.0	18.0
80	3.5	6.5	9.0	11.0	13.5	15.0	17.0	18.5	20.0

100	3.5	6.5	9.0	11.5	14.0	16.0	18.0	19.5	21.5
120	3.5	6.5	9.0	11.5	14.0	16.5	18.5	20.5	22.5
No limit	3.5	6.5	9.0	12.0	14.5	17.0	19.0	21.0	23.0
Enclosing rectangle 18m high									
3	1.0	1.5	2.0	2.5	2.5	3.0	3.5	4.0	4.0
6	1.5	2.5	3.5	4.0	4.5	5.0	5.5	6.0	6.5
9	2.0	3.5	4.5	5.0	6.0	6.5	7.0	8.0	8.5
12	2.5	4.0	5.0	6.0	7.0	7.5	8.5	9.0	10.0
15	2.5	4.5	6.0	7.0	8.0	8.5	9.5	10.5	11.0
18	2.5	5.0	6.5	7.5	8.5	9.5	11.0	11.5	13.0
21	3.0	5.5	7.0	8.0	9.5	10.5	11.5	12.5	13.0
24	3.0	5.5	7.5	8.5	10.0	11.0	12.0	13.0	14.0
27	3.5	6.0	8.0	9.0	10.5	11.5	12.5	13.5	14.5
30	3.5	6.5	8.0	9.5	11.0	12.0	13.5	14.5	15.5
40	4.0	7.0	9.0	11.0	12.0	13.5	15.0	16.5	17.5
50	4.0	7.0	9.5	11.5	13.0	15.0	16.5	18.0	19.0
60	4.0	7.5	10.0	12.0	14.0	16.0	17.5	19.5	20.5
80	4.0	7.5	10.0	13.0	15.0	17.0	19.0	21.0	22.5
100	4.0	7.5	10.0	13.5	16.0	18.0	20.5	22.5	24.0
120	4.0	7.5	10.0	14.0	16.5	19.0	21.0	23.5	25.5
No limit	4.0	8.0	10.0	14.0	17.0	19.5	22.0	24.0	26.5
Enclosing rectangle 21m high									
3	0.5	1.5	2.0	2.5	3.0	3.0	3.5	4.0	4.5
6	1.5	2.5	3.5	4.0	5.0	5.5	6.0	6.5	7.0
9	2.0	3.5	4.5	5.5	6.5	7.0	7.5	8.5	9.0
12	2.5	4.0	5.5	6.5	7.5	8.5	9.0	10.0	10.5
15	2.5	5.0	6.5	7.5	8.5	9.5	10.5	11.0	12.0
18	3.0	5.5	7.0	8.0	9.5	10.5	11.5	12.5	13.0
21	3.0	6.0	7.5	9.0	10.5	11.0	12.5	13.5	14.0
24	3.5	6.0	8.0	9.5	10.5	12.0	13.0	14.0	15.0
27	3.5	6.5	8.5	10.0	11.5	13.0	14.0	15.0	16.0
30	4.0	7.0	9.0	10.5	12.0	13.0	14.5	16.0	16.5
40	4.5	7.5	10.0	12.0	13.5	15.0	16.5	18.0	19.0
50	4.5	8.0	11.0	13.0	14.5	16.5	18.0	20.0	21.0
60	4.5	8.5	11.5	13.5	15.5	17.5	19.5	21.0	22.5
80	4.5	8.5	12.0	14.5	17.0	19.0	21.0	23.5	25.0
100	4.5	9.0	12.0	15.5	18.0	20.5	22.5	25.0	27.0
120	4.5	9.0	12.0	16.0	18.5	21.5	23.5	26.5	28.5
No limit	4.5	9.0	12.0	16.0	19.0	22.0	25.0	26.5	29.5
Enclosing rectangle 24m high									
3	0.5	1.5	2.0	2.5	3.0	3.5	3.5	4.0	4.5
6	1.5	2.5	3.5	4.5	5.0	5.5	6.0	7.0	7.0
9	2.0	3.5	5.0	5.5	6.5	7.5	8.0	9.0	9.5
12	2.5	4.5	6.0	7.0	8.0	8.5	9.5	10.5	11.5
15	3.0	5.0	6.5	8.0	9.0	10.0	11.0	12.0	13.0
18	3.0	5.5	7.5	8.5	10.0	11.0	12.0	13.0	14.0
21	3.5	6.0	8.0	9.5	10.5	12.0	13.0	14.0	15.0
24	3.5	6.5	8.5	10.0	11.5	12.5	14.0	15.0	16.0
27	4.0	7.0	9.0	11.0	12.5	13.5	15.0	16.0	17.0
30	4.0	7.5	9.5	11.5	13.0	14.0	15.5	17.0	18.0
40	4.5	8.5	11.0	13.0	14.5	16.0	18.0	19.0	20.5
50	5.0	9.0	12.0	14.0	16.0	17.5	19.5	21.0	22.5
60	5.0	9.5	12.5	15.0	17.0	19.0	21.0	23.0	24.5
80	5.0	10.0	13.5	16.5	18.5	21.0	23.5	25.5	27.5

100	5.0	10.0	13.5	17.0	20.0	22.5	25.0	27.5	29.5
120	5.5	10.0	13.5	17.5	20.5	23.5	26.5	29.0	31.0
No limit	5.5	10.0	13.5	18.0	21.0	24.0	27.5	30.0	32.5
Enclosing rectangle 27m high									
3	1.0	1.5	2.0	2.5	3.0	3.5	4.0	4.0	4.5
6	1.5	2.5	3.5	4.5	5.0	6.0	6.5	7.0	7.5
9	2.0	3.5	5.0	6.0	7.0	7.5	8.5	9.5	10.0
12	2.5	4.5	6.0	7.0	8.0	9.0	10.5	11.0	12.0
15	3.0	5.5	7.0	8.5	9.5	10.5	11.5	12.5	13.5
18	3.5	6.0	8.0	9.0	10.5	11.5	12.5	13.5	14.5
21	3.5	6.5	8.5	10.0	11.5	13.0	14.0	15.0	16.0
24	3.5	7.0	9.0	11.0	12.5	13.5	15.0	16.0	17.0
27	4.0	7.5	10.0	11.5	13.0	14.0	16.0	17.0	18.0
30	4.0	8.0	10.0	12.0	13.5	15.0	17.0	18.0	19.0
40	5.0	9.0	11.5	14.0	15.5	17.5	19.0	20.5	22.0
50	5.5	9.5	12.5	15.0	17.0	19.0	21.0	22.5	24.0
60	5.5	10.5	13.5	16.0	18.5	20.5	22.5	24.5	26.5
80	6.0	11.0	14.5	17.5	20.5	22.5	25.0	27.5	29.5
100	6.0	11.0	15.5	19.0	21.5	24.5	27.0	30.0	32.0
120	6.0	11.5	15.5	19.5	22.5	26.0	28.5	32.0	34.0
No limit	6.0	11.5	15.5	20.0	23.5	27.0	29.5	33.0	35.0

TABLE 2: COMPARTMENTS OF STATION COMMERCIAL AND ANCILLARY AREA

Width of enclosing rectangle in metre	Distance in metres from relevant boundary for unprotected percentage not exceeding								
	20	30	40	50	60	70	80	90	100
Enclosing rectangle 3m high									
3	1.0	1.5	2.0	2.0	2.5	2.5	2.5	3.0	3.0
6	1.5	2.0	2.5	3.0	3.0	3.5	3.5	4.0	4.0
9	1.5	2.5	3.0	3.5	4.0	4.0	4.5	5.0	5.0
12	2.0	2.5	3.0	3.5	4.0	4.5	5.0	5.5	5.5
15	2.0	2.5	3.5	4.0	4.5	5.0	5.5	6.0	6.0
18	2.0	2.5	3.5	4.0	5.0	5.0	6.0	6.5	6.5
21	2.0	3.0	3.5	4.5	5.0	5.5	6.0	6.5	7.0
24	2.0	3.0	3.5	4.5	5.0	5.5	6.0	7.0	7.5
27	2.0	3.0	4.0	4.5	5.5	6.0	6.5	7.0	7.5
30	2.0	3.0	4.0	4.5	5.5	6.0	6.5	7.5	8.0
40	2.0	3.0	4.0	5.0	5.5	6.5	7.0	8.0	8.5
50	2.0	3.0	4.0	5.0	6.0	6.5	7.5	8.0	9.0
60	2.0	3.0	4.0	5.0	6.0	7.0	7.5	8.5	9.5
80	2.0	3.0	4.0	5.0	6.0	7.0	8.0	9.0	9.5
No limit	2.0	3.0	4.0	5.0	6.0	7.0	8.0	9.0	10.0
Enclosing rectangle 6m high									
3	1.5	2.0	2.5	3.0	3.0	3.5	3.5	4.0	4.0
6	2.0	3.0	3.5	4.0	4.5	5.0	5.5	5.5	6.0
9	2.5	3.5	4.5	5.0	5.5	6.0	6.5	7.0	7.0
12	3.0	4.0	5.0	5.5	6.5	7.0	7.5	8.0	8.5
15	3.0	4.5	5.5	6.0	7.0	7.5	8.0	9.0	9.0
18	3.5	4.5	5.5	6.5	7.5	8.0	9.0	9.5	10.0
21	3.5	5.0	6.0	7.0	8.0	9.0	9.5	10.0	10.5
24	3.5	5.0	6.0	7.0	8.5	9.5	10.0	10.5	11.0
27	3.5	5.0	6.5	7.5	8.5	9.5	10.5	11.0	12.0
30	3.5	5.0	6.5	8.0	9.0	10.0	11.0	12.0	12.5
40	3.5	5.5	7.0	8.5	10.0	11.0	12.0	13.0	14.0
50	3.5	5.5	7.5	9.0	10.5	11.5	13.0	14.0	15.0
60	3.5	5.5	7.5	9.5	11.0	12.0	13.5	15.0	16.0

80	3.5	6.0	7.5	9.5	11.5	13.0	14.5	16.0	17.5
100	3.5	6.0	8.0	10.0	12.0	13.5	15.0	16.5	18.0
120	3.5	6.0	8.0	10.0	12.0	14.0	15.5	17.0	19.0
No limit	3.5	6.0	8.0	10.0	12.0	14.0	16.0	18.0	19.0
Enclosing rectangle 9m high									
3	1.5	2.5	3.0	3.5	4.0	4.0	4.5	5.0	5.0
6	2.5	3.5	4.5	5.0	5.5	6.0	6.5	7.0	7.0
9	3.5	4.5	5.5	6.0	6.5	7.5	8.0	8.5	9.0
12	3.5	5.0	6.0	7.0	7.5	8.5	9.0	9.5	10.5
15	4.0	5.5	6.5	7.5	8.5	9.5	10.0	11.0	11.5
18	4.5	6.0	7.0	8.5	9.5	10.0	11.0	12.0	12.5
21	4.5	6.5	7.5	9.0	10.0	11.0	12.0	13.0	13.5
24	5.0	6.5	8.0	9.5	11.0	12.0	13.0	13.5	14.5
27	5.0	7.0	8.5	10.0	11.5	12.5	13.5	14.5	15.0
30	5.0	7.0	9.0	10.5	12.0	13.0	14.0	15.0	16.0
40	5.5	7.5	9.5	11.5	13.0	14.5	15.5	17.0	17.5
50	5.5	8.0	10.0	12.5	14.0	15.5	17.0	18.5	19.5
60	5.5	8.0	11.0	13.0	15.0	16.5	18.0	19.5	21.0
80	5.5	8.5	11.5	13.5	16.0	17.5	19.5	21.5	23.0
100	5.5	8.5	11.5	14.5	16.5	18.5	21.0	22.5	24.5
120	5.5	8.5	11.5	14.5	17.0	19.5	21.5	23.5	26.0
No limit	5.5	8.5	11.5	15.0	17.5	20.0	22.5	24.5	27.0
Enclosing rectangle 12m high									
3	2.0	2.5	3.0	3.5	4.0	4.5	5.0	5.5	5.5
6	3.0	4.0	5.0	5.5	6.5	7.0	7.5	8.0	8.5
9	3.5	5.0	6.0	7.0	7.5	8.5	9.0	9.5	10.5
12	4.5	6.0	7.0	8.0	9.0	9.5	11.0	11.5	12.0
15	5.0	6.5	8.0	9.0	10.0	11.0	12.0	13.0	13.5
18	5.0	7.0	8.5	10.0	11.0	12.0	13.0	14.0	14.5
21	5.5	7.5	9.0	10.5	12.0	13.0	14.0	15.0	16.0
24	6.0	8.0	9.5	11.5	12.5	14.0	15.0	16.0	16.5
27	6.0	8.0	10.5	12.0	13.5	14.5	16.0	17.0	17.5
30	6.5	8.5	10.5	12.5	14.0	15.0	16.5	17.5	18.5
40	6.5	9.5	12.0	14.0	15.5	17.5	18.5	20.0	21.0
50	7.0	10.0	13.0	15.0	17.0	19.0	20.5	23.0	23.0
60	7.0	10.5	13.5	16.0	18.0	20.0	21.5	23.5	25.0
80	7.0	11.0	14.5	17.0	19.5	21.5	23.5	26.0	27.5
100	7.5	11.5	15.0	18.0	21.0	23.0	25.5	28.0	30.0
120	7.5	11.5	15.0	18.5	22.0	24.0	27.0	29.5	31.5
No limit	7.5	12.0	15.5	19.0	22.5	25.0	28.0	30.5	34.0
Enclosing rectangle 15m high									
3	2.0	2.5	3.5	4.0	4.5	5.0	5.35	6.0	6.0
6	3.0	4.5	5.5	6.0	7.0	7.5	8.0	9.0	9.0
9	4.0	5.5	6.5	7.5	8.5	9.5	10.0	11.0	11.5
12	5.0	6.5	8.0	9.0	10.0	11.0	12.0	13.0	13.5
15	5.5	7.0	9.0	10.0	11.5	12.5	13.5	14.5	15.0
18	6.0	8.0	9.5	11.0	12.5	13.5	14.5	15.5	16.5
21	6.5	8.5	10.5	12.0	13.5	14.5	16.0	16.5	17.5
24	6.5	9.0	11.0	13.0	14.5	15.5	17.0	18.0	19.0
27	7.0	9.5	11.5	13.5	15.0	16.5	18.0	19.0	20.0
30	7.5	10.0	12.0	14.0	16.0	17.0	18.5	20.0	21.0
40	8.0	11.0	13.5	16.0	18.0	19.5	21.0	22.5	23.5
50	8.5	12.0	15.0	17.5	19.5	21.9	23.0	25.0	26.0
60	8.5	12.5	15.5	18.0	21.0	23.5	25.0	27.0	28.0

80	9.0	13.5	17.0	20.0	23.0	25.5	28.0	30.0	31.5
100	9.0	14.0	18.0	21.5	24.5	27.5	30.0	32.5	34.5
120	9.0	14.0	18.5	22.5	25.5	28.5	31.5	34.5	37.0
No limit	9.0	14.5	19.0	23.0	27.0	30.0	34.0	36.0	39.0
Enclosing rectangle 18m high									
3	2.0	2.5	3.5	4.0	5.0	5.0	6.0	6.5	6.5
6	3.5	4.5	5.5	6.5	7.5	8.0	9.0	9.5	10.0
9	4.5	6.0	7.0	8.5	9.5	10.0	11.0	12.0	12.5
12	5.0	7.0	8.5	10.0	11.0	12.0	13.0	14.0	14.5
15	6.0	8.0	9.5	11.0	12.5	13.5	14.5	15.5	16.5
18	6.5	8.5	11.0	12.0	13.5	14.5	16.0	17.0	18.0
21	7.0	9.0	11.5	13.0	14.5	16.0	17.0	18.0	19.5
24	7.5	10.0	12.0	14.0	15.5	16.5	18.5	19.5	20.5
27	8.0	10.5	12.5	14.5	16.5	17.5	19.5	20.5	21.5
30	8.0	11.0	13.5	15.5	17.0	18.5	20.5	21.5	22.5
40	9.0	12.0	15.0	17.5	19.5	21.5	23.5	25.0	26.0
50	9.5	13.0	16.5	19.0	21.5	23.5	26.0	27.5	29.0
60	10.0	14.0	17.5	20.5	23.0	26.0	27.5	29.5	31.0
80	10.0	15.0	19.0	22.5	26.0	28.5	31.0	33.5	35.0
100	10.0	16.0	20.5	24.0	28.0	31.0	33.5	36.0	38.5
120	10.0	16.5	21.0	25.5	29.5	32.5	35.5	39.0	41.5
No limit	10.0	17.0	22.0	26.5	30.5	34.0	37.0	41.0	43.5
Enclosing rectangle 21m high									
3	2.0	3.0	3.5	4.5	5.0	5.5	6.0	6.5	7.0
6	3.5	5.0	6.0	7.0	8.0	9.0	9.5	10.0	10.5
9	4.5	6.5	7.5	9.0	10.0	11.0	12.0	13.0	13.5
12	5.5	7.5	9.0	10.5	12.0	13.0	14.0	15.0	16.0
15	6.5	8.5	10.5	12.0	13.5	14.5	16.0	16.5	17.5
18	7.0	9.5	11.5	13.0	14.5	16.0	17.0	18.0	19.5
21	7.5	10.0	12.5	14.0	15.5	17.0	18.5	20.0	21.0
24	8.0	10.5	13.0	15.0	16.0	18.0	20.0	21.0	22.0
27	8.5	11.5	14.0	16.0	18.0	19.0	21.0	22.5	23.5
30	9.0	12.0	14.5	16.5	18.5	20.5	22.0	23.5	25.0
40	10.0	13.5	16.5	19.0	21.5	23.0	25.5	27.0	28.5
50	11.0	14.5	18.0	21.0	23.5	25.5	28.0	30.0	31.5
60	11.5	15.5	19.5	22.5	25.5	28.0	30.5	32.5	33.5
80	12.0	17.0	21.0	25.0	28.5	31.5	34.0	36.5	38.5
100	12.0	18.0	22.5	27.0	31.0	34.5	37.0	40.0	42.0
120	12.0	18.5	23.5	28.5	32.5	36.5	39.5	43.0	45.5
No limit	12.0	19.0	25.0	29.5	34.5	38.0	41.5	45.5	48.0
Enclosing rectangle 24m high									
3	2.0	3.0	3.5	4.5	5.0	5.5	6.0	7.0	7.5
6	3.5	5.0	6.0	7.0	8.5	9.5	10.0	10.5	11.0
9	5.0	6.5	8.0	9.5	11.0	12.0	13.0	13.5	14.5
12	6.0	8.0	9.5	11.5	12.5	14.0	15.0	16.0	16.5
15	6.5	9.0	11.0	13.0	14.5	15.5	17.0	18.0	19.0
18	7.5	10.0	12.0	14.0	15.5	16.5	18.5	19.5	20.5
21	8.0	10.5	13.0	15.0	16.5	18.0	20.0	21.0	22.0
24	8.5	11.5	14.0	16.0	18.0	19.5	21.0	22.5	24.0
27	9.0	12.5	15.0	17.0	19.0	20.5	21.5	24.0	25.5
30	9.5	13.0	15.5	18.0	20.0	21.5	23.5	25.0	26.5
40	11.0	14.5	18.0	20.5	23.0	25.0	27.5	29.0	30.5
50	12.0	16.0	19.5	22.5	25.5	27.5	30.0	32.0	33.5
60	12.5	17.0	21.0	24.5	27.5	30.0	32.5	35.0	36.5

80	13.5	18.5	23.5	27.5	31.0	34.5	37.0	39.5	41.5
100	13.5	20.0	25.0	29.5	33.5	37.0	40.0	43.0	45.5
120	13.5	20.5	26.5	31.0	36.0	39.5	43.0	46.5	49.0
No limit	13.5	21.0	27.5	32.5	37.5	42.0	45.5	49.5	52.0
Enclosing rectangle 27m high									
3	2.0	3.0	4.0	4.5	5.5	6.0	6.5	7.0	7.5
6	3.5	5.0	6.5	7.5	8.5	9.5	10.5	11.0	12.0
9	5.0	7.0	8.5	10.0	11.5	12.5	13.5	14.5	15.0
12	6.0	8.0	10.5	12.0	13.5	14.5	16.0	17.0	17.5
15	7.0	9.5	11.5	13.5	15.0	16.5	18.0	19.0	20.0
18	8.0	10.5	12.5	14.5	16.5	17.5	19.5	20.5	21.5
21	8.5	11.5	14.0	16.0	18.0	19.0	21.0	22.5	23.5
24	9.0	12.5	15.0	17.0	19.0	20.5	22.5	24.0	25.5
27	10.0	13.0	16.0	18.0	20.0	22.0	24.0	25.5	27.0
30	10.0	13.5	17.0	19.0	21.0	23.0	25.0	26.5	28.0
40	11.5	15.5	19.0	22.0	24.5	26.5	29.0	30.5	32.5
50	12.5	17.0	21.0	24.0	27.0	29.5	32.0	34.5	36.0
60	13.5	18.5	22.5	26.5	29.5	32.0	35.0	37.0	39.0
80	14.5	20.5	25.0	29.5	33.0	36.5	39.5	42.0	44.0
100	15.5	21.5	27.0	32.0	36.5	40.5	43.0	46.5	48.5
120	15.5	22.5	28.5	34.0	39.5	43.0	46.5	50.5	53.0
No limit	15.5	23.5	29.5	35.0	40.5	44.5	48.5	52.0	55.5

Clause No.	Amendment Date	Effective Date	Clause Status	Clause Before Amendment	Circular Date
------------	----------------	----------------	---------------	-------------------------	---------------

CLAUSE 4.1 GENERAL

The purpose of this Chapter is to make provision for space around stations to enable effective external firefighting operations.

CLAUSE 4.2 PROVISION FOR EXTERNAL ACCESS TO STATION FOR FIREFIGHTING AND ACCESSIBILITY OF SITE TO FIREFIGHTING APPLIANCES

4.2.1 General

- a. Fire engine accessways/ fire engine access roads shall be provided to ensure site accessibility for firefighting appliances.
- b. Fire engine accessways/ fire engine access roads shall have an adequate clear width for the deployment of firefighting appliances, in accordance with the habitable height, as stipulated in Table 4.2.1.

TABLE 4.2.1: FIRE ENGINE ACCESSWAY/ FIRE ENGINE ACCESS ROAD			
Details	Habitable Height (m)		
	≤ 10	> 10 & ≤ 50	> 50
Width of fire engine access road	≥ 4m		
Width of fire engine accessway	Not required	≥ 6m	≥ 7m
Length of fire engine accessway	-	See Table 4.2.4a.(2)	
Type of firefighting appliance	Pump ladder	CPL 34 & AL 56	AL 56, CPL 60 & HLA 90
Loading capacity of fire engine road #	≥ 24 tonnes	≥ 30 tonnes	≥ 50 tonnes
Loading capacity of fire engine accessway #	-	≥ 30 tonnes	≥ 50 tonnes
Axle/Jack loading	See Table 4.2.4d.(2)-1 & Table 4.2.4d.(2)-2		
Turning facility	See Diagram 4.2.4f.		
U-turn radii			
Note:			
# - The appended figures for loading capacity of fire engine accessway/ fire engine access road are characteristic values.			

- c. Fire access openings to compartment or spaces

For aboveground stations exceeding the habitable height of 10m, fire access openings are required at every storey/ level, except the 1st storey, and shall face the fire engine accessway directly.

4.2.2 Fire access openings to aboveground stations

Rationale

The purpose of providing fire access openings is to enable firefighters to gain access into the station from the external to rescue any trapped occupant and to facilitate external firefighting. Fire access openings shall not be located at exit staircases or at smoke free/fire lift lobbies as these areas can be accessed through more conventional means.

- a. Fire access openings shall be provided on the external wall for external firefighting operations. This can include unobstructed external wall openings, windows, balcony doors, glazed wall panels, and access panels. Windows, doors, wall panels, and access panels shall be readily openable from the inside and outside. The inside and outside of fire access openings shall be unobstructed at all times during the occupancy of the station. There shall be no furniture or any other obstruction within 1m from the fire access openings at the landing inside the station.

- b. Signage

Panels to fire access openings shall be indicated with either a red or orange triangle of equal sides (minimum 150mm on each side), which can be upright or inverted, on the external side of the wall and with wordings "Firefighting Access - Do Not Obstruct" of at least 25mm height on the internal side.

The signage provided on the external side of the fire access panels, either red or orange triangle helps firefighters on the ground to locate the designated fire access openings.

Explanation and Illustrations



The access openings signage provided on the external side, either red or orange triangle would help firefighters on the ground to locate the designated access openings.

- c. Size

Fire access openings shall be no less than 850mm wide by 1m high with sill height of not more than 1.1m and head height of not less than 1.8m above the inside finished floor level.

Exception:

(1) The sill height can be extended to at most 1.25m for those fire access openings that are located at roof garden/ terrace.

Rationale

The sill height of not more than 1.1m is to facilitate the free movement of firefighters into or out of the building. Higher sill height may impede their access and increases their risk of falling.

Explanation and Illustrations

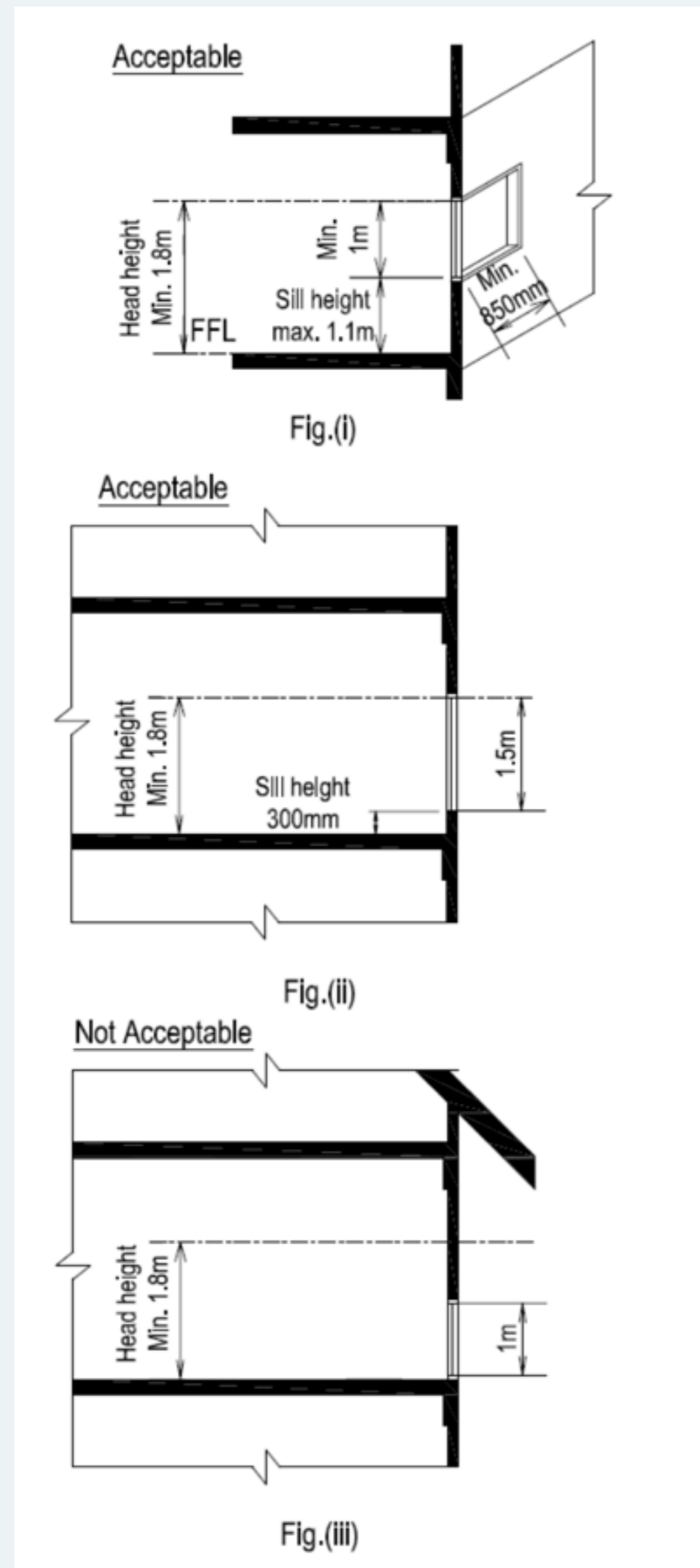

d. Location

The fire access openings shall be placed against an occupied space. It shall not be placed at plant/ store room, exit staircase, smoke-free approach to exit staircase or space that leads only to a dead end.

e. Number and position of fire access openings

(1) Number of fire access openings

Every 20m of fire engine accessway or part thereof shall be provided with an access opening.

(2) Position of fire access openings

Fire access openings shall be remote from each other and located along the side of the station. Such fire access openings shall be spaced at most 20m apart measured along the external wall from centre to centre of the fire access openings. The fire access openings shall be distributed such that there is at least one opening at every 20m of the fire engine accessway.

(3) Additional openings for ventilation

For an area or space has a ceiling height greater than 10m, additional high level ventilation openings for smoke venting and firefighting purposes shall be provided and located in the external walls opening into the area or space. The ventilation opening shall meet the following criteria:

- (a) the number and location of the openings shall comply with [Cl.4.2.2e.\(1\)](#) and [Cl.4.2.2e.\(2\)](#);
- (b) the dimensions of the openings shall comply with [Cl.4.2.2c.](#);
- (c) the openings can be in the form of openable panels/ louvres, breakable glazing, or permanent openings; and
- (d) the openings shall not be indicated with the triangular signage as mentioned under [Cl.4.2.2b.](#), but instead be labelled with red wording, "DO NOT ENTER – FOR SMOKE VENTING ONLY", of height not less than 50mm and visible from the station exterior.

4.2.3 Firefighting staircase

- a. At least one exit staircase shall be designated as a firefighting staircase provided for every underground station.
- b. The entrance to firefighting staircase on the ground level shall be visible and within 18m from a fire engine accessway/ fire engine access road.
- c. Firefighting staircase shall have access to every basement storey via smoke-free lobby/ fire lift lobby.
- d. The size of the smoke-free lobby/ fire lift lobby adjacent to a firefighting staircase and/ or fire lift lobby shall be at least 6m² and with minimum clear width of 2m. The floor shall be graded from the lift door towards the lobby door with a fall not exceeding 1 in 200.

4.2.4 Fire engine accessway and fire engine access road

a. Aboveground stations

AFA (m ²)	Required length of perimeter	
	Non-sprinkler-protected	Sprinkler-protected*
≤ 2000	1/3 (at least 15m)	1/3 (at least 15m)
> 2000 and ≤ 4000	1/4	

> 4000 and ≤ 8000	½	¼
> 8000 and ≤ 16000	¾	½
> 16000 and ≤ 32000	island site	¾
> 32000		island site
Note:		
* – Station that comply with Cl.6.4.1 is deemed as sprinkler-protected		

(1) For stations not exceeding the habitable height of 10m, fire engine accessway is not required. However, a fire engine access road for firefighting appliances shall be provided to within a travel distance of 45m of every point on the projected plan area of the station.

(2) For stations exceeding the habitable height of 10m, fire engine accessway shall be located directly below the fire access openings to provide direct reach to the designated fire access openings. The required length of fire engine accessway shall be computed based on the largest AFA as shown in [Table 4.2.4a.\(2\)](#).

Explanation and Illustrations

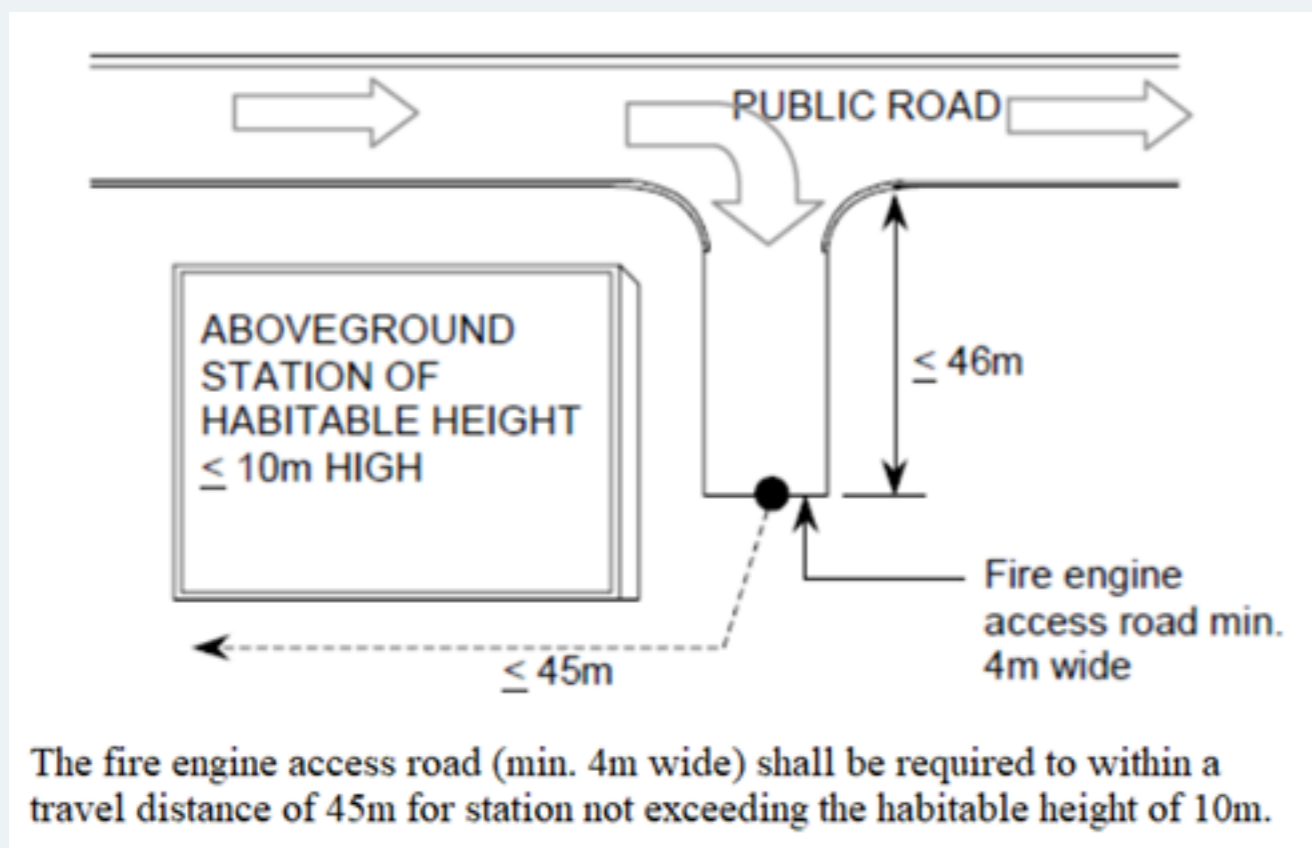

(a) For stations with interconnected floors, including basements connected to aboveground floors, the AFA shall be the aggregate AFA of all the interconnected floors.

(b) For stations with more than one group of interconnected floors, the AFA shall be taken as the largest of the aggregate floor areas among the groups of interconnected floors.

(3) Open-sided covered link bridge/ linkway used for station evacuation shall be included in the station AFA computation, measured up to 6m from the start of link bridge/ linkway. There shall not be any commercial activities or other usage that would pose a fire risk within the link bridge/ linkway.

Explanation and Illustrations

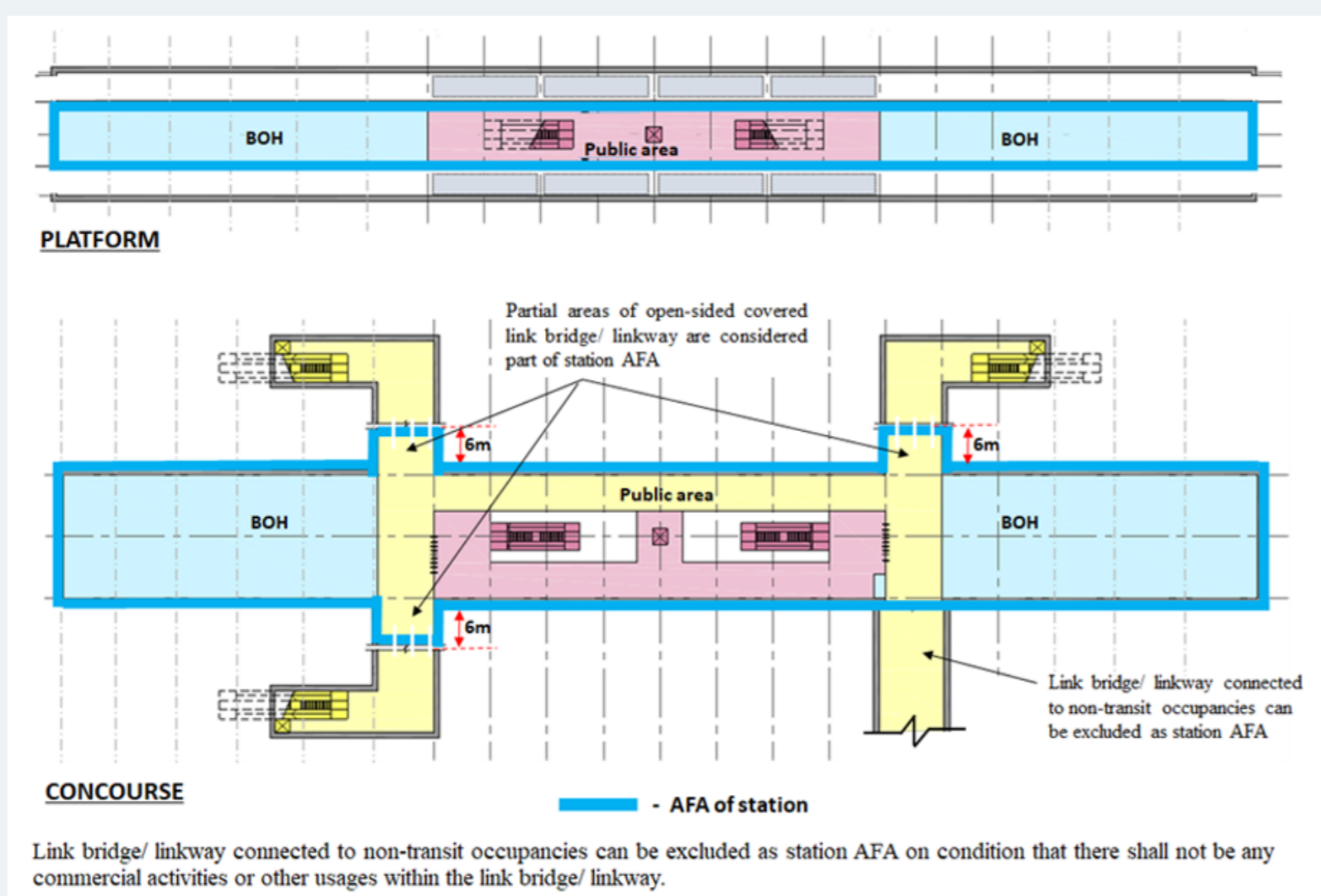

b. Underground stations

For underground station, the fire engine accessway/ fire engine access road shall be provided to within a travel distance of 18m to the entrance of all exit staircases where landing valves (dry riser) are provided in accordance with [Cl.6.2.2b.\(2\)\(c\)](#). The measurement of 18m shall be between the fire engine accessway/ fire engine access road and the entrance of exit staircase.

Explanation and Illustrations

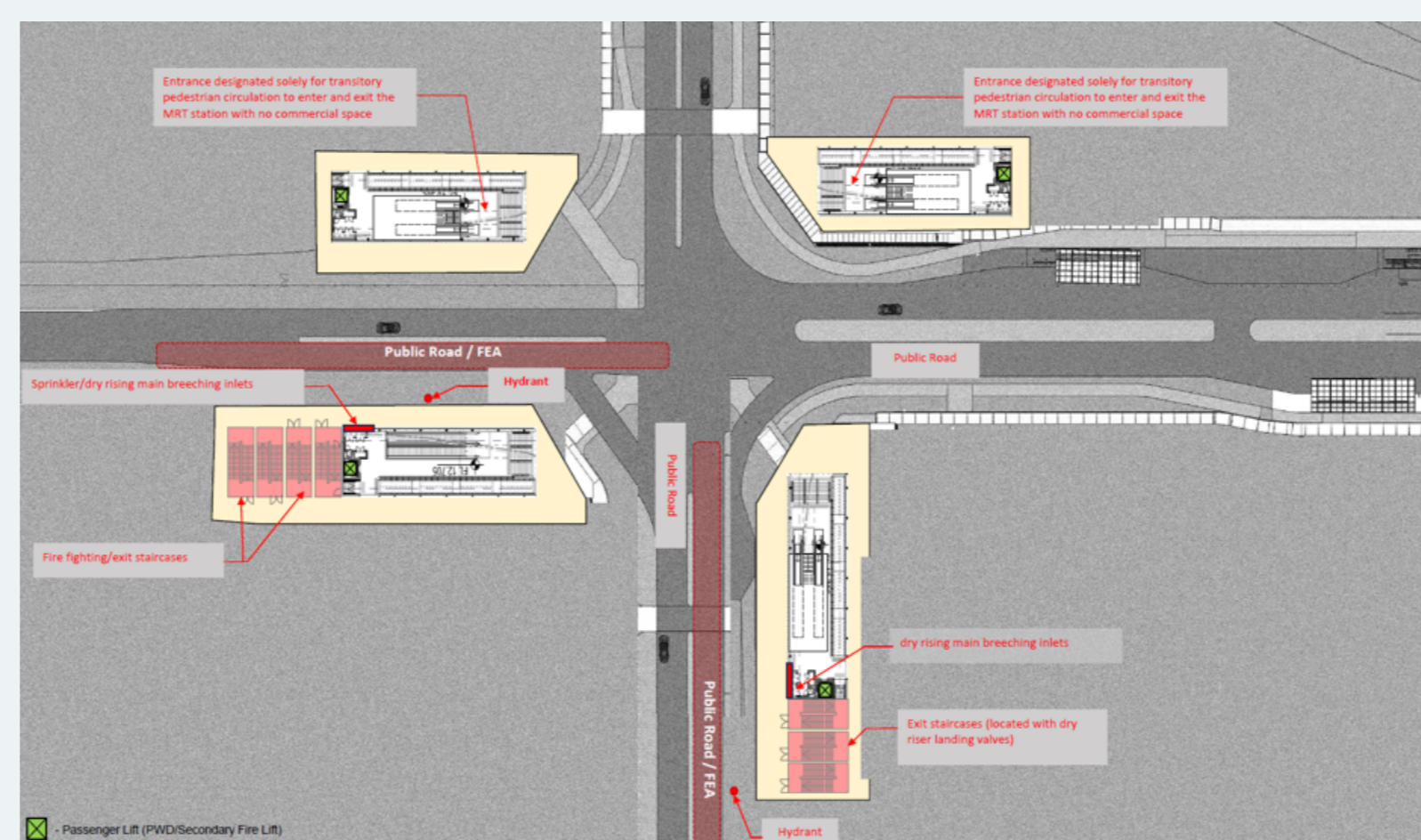

Where standalone entrances to underground station are solely transitory pedestrian circulation space (i.e. transient spaces) and without any commercial activities or other usages, provision of fire engine accessway/ fire engine access road is not required for these standalone entrances due to low fire risk.

To ensure site accessibility for firefighting appliances to underground station are intact, full compliance to [Cl.4.2.3b.](#) (entrance to firefighting staircase), [Clause 4.3](#) (breaching inlets for rising mains and automatic sprinkler system) & [Cl.8.6.1d](#) (FCC location) are required.

c. Location

The fire engine accessway shall be positioned so that the nearer edge shall be at least 2m or at most 10m from the centre position of the access opening, measured horizontally.

Exception:

(1) The horizontal distance can be extended to at most 13m, provided the height between the fire engine accessway and centre position of the fire access openings is not more than 20m.

d. Design of fire engine accessway and fire engine access road

(1) Fire engine accessway sizes

The minimum width, length and turning radii of a fire engine accessway shall be in accordance with [Table 4.2.1](#) and [Diagram 4.2.4f](#). [Diagram 4.2.4d.\(1\) – 1 to 3](#) shows the relationship between the fire engine accessway and parked firefighting appliance with its front and rear jacks extended.

(2) Fire engine accessways and fire engine access roads, which can be on suspended slabs, metalled/ non-metalled roads, paved/ non-paved surfaces, ground laid with strengthened perforated slabs, etc., shall be designed to withstand both stationary and axle loading capacity of firefighting appliances respectively as stipulated in [Table 4.2.4d.\(2\)-1](#) and [Table 4.2.4d.\(2\)-2](#). Where a fire engine access road is used for linking fire engine accessway, its loading and turning radius shall comply with the specifications for fire engine accessway.

TABLE 4.2.4d.(2)-1: JACK LOADING OF FIREFIGHTING APPLIANCES				
Type of Fire Appliance	CPL 34	AL 56	CPL 60	HLA 90
Jack load contact area	5625 cm ²	5625 cm ²	7125 cm ²	7125 cm ²
Maximum pressure per Jack (4 jacks per vehicle)	37 N/cm ²	37 N/cm ²	37 N/cm ²	80 N/cm ²
Note: The appended figures for jack loading are characteristic values.				

TABLE 4.2.4d.(2)-2: AXLE LOADING OF FIREFIGHTING APPLIANCES										
Axle No. (from front)	Type of firefighting appliances									
	Pump Ladder		CPL 34		AL 56		CPL 60		HLA 90	
	Loading Wt. (kg)	No of wheels	Loading Wt. (kg)	No of wheels	Loading Wt. (kg)	No of wheels	Loading Wt. (kg)	No of wheels	Loading Wt. (kg)	No of wheels
Axle 1	10000	2	7500	2	9000	2	9000	2	9000	2
Axle 2	14000	2	10500	2	10500	4	9900	4	9000	2
Axle 3	-	-	10500	4	10500	4	9900	4	10500	4
Axle 4	-	-	-	-	-	-	8200	2	10500	4
Axle 5	-	-	-	-	-	-	-	-	10000	2
Axle 6	-	-	-	-	-	-	-	-	-	-
Note: The appended figures for axle loading are characteristic values.										

e. Gradients

Fire engine accessway shall be laid on a level platform or if on an incline, the gradient shall not exceed 1:15. A fire engine access road shall be laid on an incline not exceeding a gradient of 1:8.3.

f. Turning facilities

(1) A dead-end fire engine accessway/ fire engine access road shall not exceed 46m in length. If exceeding 46m, it shall be provided with cul-de-sac turning facilities as shown in [Diagram 4.2.4f](#).

(2) The U-turn radii for firefighting appliances on a fire engine accessway/ fire engine access road shall comply with the requirements as shown in [Diagram 4.2.4f](#).

g. Overhead clearance

An overhead structure shall only be permitted over a fire engine accessway/ fire engine access road subject to all of the following (see [Diagram 4.2.4g](#)):

- (1) the overhead clearance for passage of firefighting appliances shall be at least 4.5m;
- (2) the width of the overhead structure shall not be more than 10m;
- (3) where more than one overhead structure span across the fire engine accessway/ fire engine access road, the separation distance between two adjacent overhead structures shall be at least 20m apart;
- (4) the length of the end-stretch of the fire engine accessway/ fire engine access road shall be at least 20m with no overhead structure; and
- (5) the length of fire engine accessway required for the station shall exclude the stretch of fire engine accessway with the overhead structure.

h. Public road

Public roads can serve as fire engine accessway provided the location of such public roads is in compliance with the requirements of distance from fire access openings.

i. Obstruction

Fire engine accessway/ fire engine access road shall be kept clear of obstructions at all times. Plants, trees or other fixtures shall not obstruct the path between the fire engine accessway and fire access openings.

Exception

(1) For unmanned building (e.g. facility building, intake substation), where an access control system such as a barrier, sliding/ swing gate, etc. is provided at the entrance into the development, such systems

(a) shall automatically open upon detection of firefighting appliances (such as In-vehicle Unit (IU) for emergency vehicles) or activation of the building fire alarm, and shall remain open until the access control system has been reset; and

(b) shall be arranged to open automatically from a fail-safe manual override device located 1.2m above the floor and within 1.5m facing the external side of the development, with the manual override device readily accessible and clearly identified by a sign that reads "Emergency Release".

(2) For manned building, the barrier at the entrance into the development shall be immediately opened/ removed upon building's fire alarm activation.

Explanation and Illustrations



j. Marking of fire engine accessway and fire engine access road

(1) All fire engine accessway shall be marked, except where public roads are designated as fire engine accessway/ fire engine access road.

(2) Metalled/ non-metalled or paved/ non-paved surface fire engine accessways/ fire engine access roads shall be marked with reflective white or yellow strips of size not less than 100mm (W) x 400mm (L), or white or yellow road stud reflectors of size not less than 100mm (W) x 100mm (L) x 18mm (H). The markings or reflectors shall be visible at all times and shall be provided on both sides of the fire engine accessways/ fire engine access roads at an alternate interval of not more than 5m. Markings or reflectors shall also mark all corners and turning corners of the fire engine accessway. See [Diagram 4.2.4j.\(2\)](#).

(3) A sign with white background and red pictogram with upper case wording of not less than 70mm in height shall be provided at the start, junction, and end of a fire engine accessway/ fire engine access road. The height measured from the ground to the lowest point of the sign shall be between 2.3m and 2.4m. The sign shall be reflective, visible, and unobstructed at all times and shall be positioned adjacent to the fire engine accessway/ fire engine access road. For locations where there are more than one of such signs, the signs can be placed on the same post. See [Diagram 4.2.4j.\(3\)](#).

Rationale

Fire engine accessway which is specially designated for operation of the firefighting appliance shall be marked with signage to prevent unauthorised parking of other vehicles. The markings in contrasting colours facilitate better visibility and easy identification for the responding firefighting crew. These markings are also to ensure that the firefighting appliances are not accidentally deployed over "suspended" or "cantilevered" slab over basement, as these are not structurally designed to take the weight of the appliances.

k. Ancillary usage of fire engine accessway/ fire engine access road

Fire engine accessway/ fire engine access road shall not be turned into other usages such as pond, water features, car parking lots (including loading & unloading), etc. Turfing designed to withstand both stationary and axle loading capacity of firefighting appliances in accordance with [Cl.4.2.4d](#). for fire engine accessway/ fire engine access road is only permitted on the straight stretch of the fire engine accessway/ fire engine access road with gradient not exceeding 1:15.

CLAUSE 4.3 ACCESS TO STATIONS WITH BREECHING INLETS

Station fitted with rising mains and automatic sprinkler system shall have fire engine accessways/ fire engine access roads for firefighting appliances within 18m of the breaching inlets. The breaching inlets shall be visible from the fire engine accessways/ fire engine access roads.

Rationale

Breaching inlets shall be visible from the fire engine accessway/ fire engine access road to avoid delay in locating them upon arrival of the firefighting crew. The breaching inlets shall not be sited more than 18m away from the fire engine accessway/fire engine access road so that only one hose length need to be deployed for connection between the fire engine appliance and breaching inlet and to limit the distance firefighters need to travel.

Explanation and Illustrations

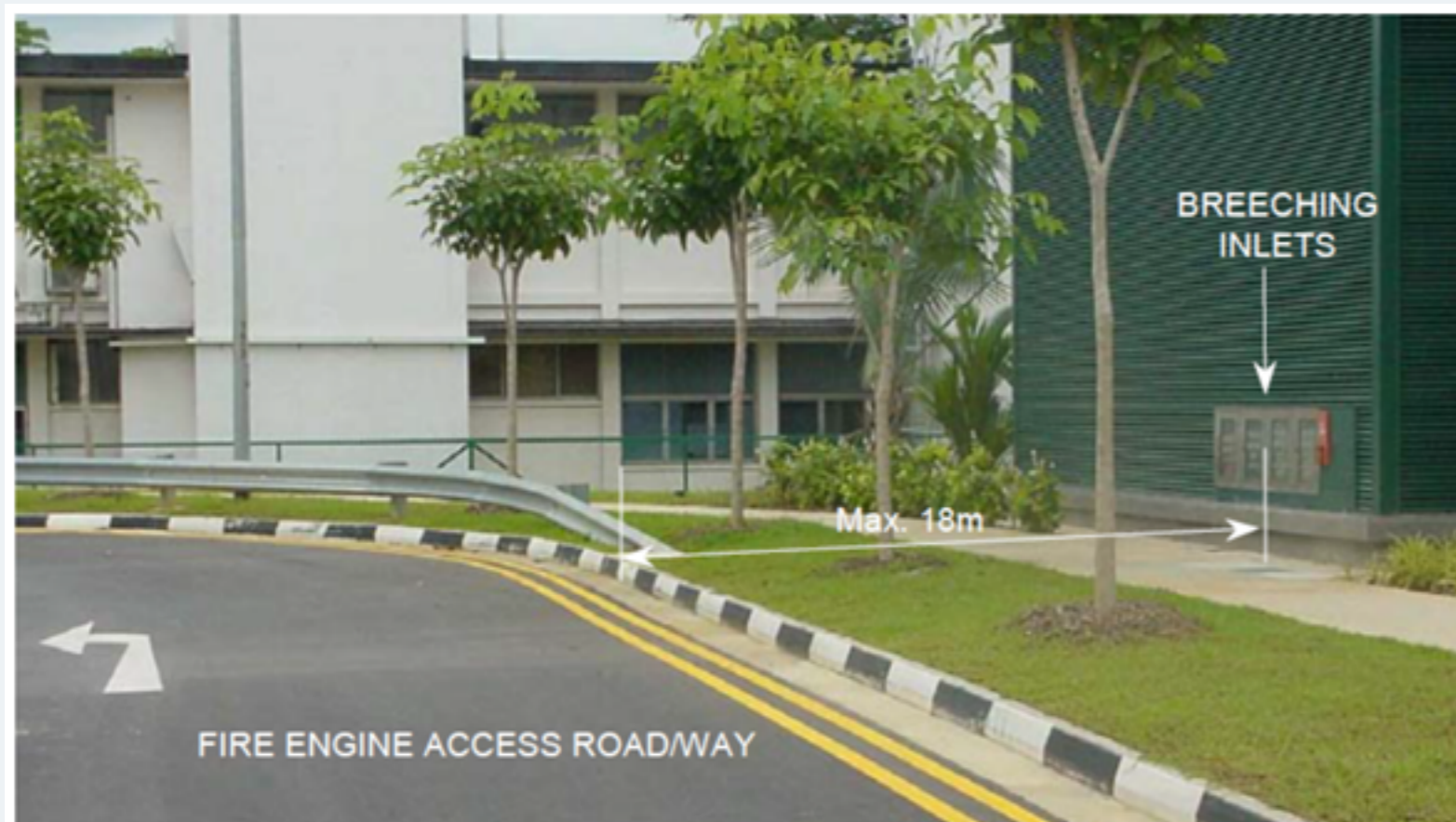

Breaching inlets shall be visible from fire engine access road/fire engine accessway to avoid delay in locating them upon arrival of fire crew. For better control and to limit to only one hose length being used to connect the fire appliance to the breaching inlets, the breaching inlets shall not be sited more than 18m away from the fire engine access road/fire engine accessway.

CLAUSE 4.4 FIRE HYDRANT

4.4.1 Provision of private fire hydrant

a. Every part of a fire engine access road and/ or fire engine accessway shall be within an unobstructed distance of 50m from a fire hydrant. Where a public hydrant conforming to such requirement is not available, private hydrant(s) shall be provided. See [Diagram 4.4.1a.](#)

b. Use of public fire hydrant

Existing public fire hydrants along one side of a public road shall not be designated to serve developments sited on the other side of the public road, except for a road having at most two lanes, regardless of traffic direction.

c. Locations of fire hydrants

In situations where more than one private fire hydrants are required, the fire hydrants shall be located along the fire engine accessway/ fire engine access road such that every part of the fire engine accessway/ fire engine access road is within an unobstructed distance of 50m from any fire hydrant. See [Diagram 4.4.1c.](#)

Rationale

Public roads with multiple lanes will likely have high volume of traffic. In the event where only one fire hydrant exists, traffic would be blocked in order for firefighters to utilize the hydrant on the opposite side of the road. This will create congestion or roadblock, thus disrupting traffic.

d. Siting and types of fire hydrants

Siting and types of fire hydrants shall comply with the requirements stated in SS 575.

e. Ringed fire hydrant pipes

For a station that is required to have an island site fire engine accessway, the fire hydrant pipe shall be a ring system. Isolation valves shall be provided on the fire hydrant ring such that on any section of ring, not more than one fire hydrant can be isolated when required for maintenance without affecting the water supply (both designed pressure and flow) to the other fire hydrants on the ring.

f. Valve locking device

A locking device shall be provided to lock the valves in open position during normal operation. Underground valves shall be kept in an open position at all times.

4.4.2 Water supply for private fire hydrant

The provision of water supply for a private fire hydrant system, where required by this Code, shall comply with the following requirements:

a. Private fire hydrant at or below reduced level 125m

(1) Private fire hydrants installed at reduced level 125m and below can receive direct supply from public water mains provided the flow and pressure from the public water mains meet the fire hydrant requirements as shown in [Table 4.4.2](#), or the following requirements are complied with:

(a) the AFA of the largest compartment shall not exceed 1000m²;

(b) the nominal bore of the fire hydrant pipe and the bulk water meter shall not be less than 150mm in diameter; and

(c) the running pressure/ flow at the hydraulically most unfavourable fire hydrant of the private fire hydrant system shall comply with the following:

(i) running pressure $\geq 0.9 \times$ (running pressure of the nearest public fire hydrant – pressure drop across the bulk water metre); and

(ii) flow rate $\geq 0.9 \times$ water flow of the nearest public fire hydrant or \geq total flow demand (as required in [Table 4.4.2](#)) of the private fire hydrant system, provided the running pressure at the most remote private fire hydrant is greater than 2 bars.

Note: In calculating the frictional loss for the private fire hydrant system, the design flow rates shown in [Table 4.4.2](#) shall be used. The pressure drops across bulk water metre shall not be more than 1 bar.

(2) If the requirements stipulated in [Cl.4.4.2a.\(1\)](#) cannot be met, a storage tank of sufficient capacity meeting the flow rate and duration as specified in [Table 4.4.2](#) with the requisite pumping facilities shall be provided.

TABLE 4.4.2: WATER SUPPLY & STORAGE REQUIREMENT FOR PRIVATE FIRE HYDRANT

Minimum running pressure	2 bars	
Minimum duration	45 mins	
Minimum flow rate	Accessible Floor Area* (m ²)	Minimum flow rate
	$\leq 1000\text{m}^2$	38 L/s
	$>1000\text{m}^2$ and $\leq 5000\text{m}^2$	57 L/s
	$> 5000\text{m}^2$	76 L/s

Note:

* – Based on the Accessible Floor Area (AFA) of the largest compartment in the station

b. Private fire hydrant above reduced level 125m

(1) Where more than one private fire hydrant is located above reduced level 125m within the same plot, storage and pumping arrangements of water supply to these specified fire hydrants shall comply with the requirements stipulated in [Cl.4.2.2c.](#)

(2) The private fire hydrant can be in the form of a dry fire hydrant, if it is not the sole fire hydrant within 50m from any breeching inlet(s) feeding firefighting systems for the station(s) within the plot of land, which include:

(a) automatic fire sprinkler systems, or

(b) dry riser systems.

(3) A dry fire hydrant shall comply with all of the following requirements:

(a) A dry private fire hydrant shall be connected to a 150mm diameter dry pipe, which shall be connected at the other end to a four-way breeching inlet.

(b) This breeching inlet shall be within 18m from any fire engine accessway/ fire engine access road having minimum 4m width and within 50m from any wet fire hydrant, private or public.

Rationale

Private hydrant located above the reduced level of 125m is required to be charged with water at all times so that firefighters could use them to feed the breeching inlets to rising mains for firefighting purposes

(c) The private dry pillar shall be painted in “yellow” and labelled “dry” on the fire hydrant pillar.E

(d) A signage indicating the location of breeching inlet shall be positioned next to the dry private fire hydrant.

c. Water supply and storage requirement

Where more than one private fire hydrant is located above reduced level 125m within the same plot, storage and pumping arrangements of water supply to these specified fire hydrants shall comply with those for wet rising mains stipulated in SS 575 and [Table 4.4.2](#).

Explanation and Illustrations

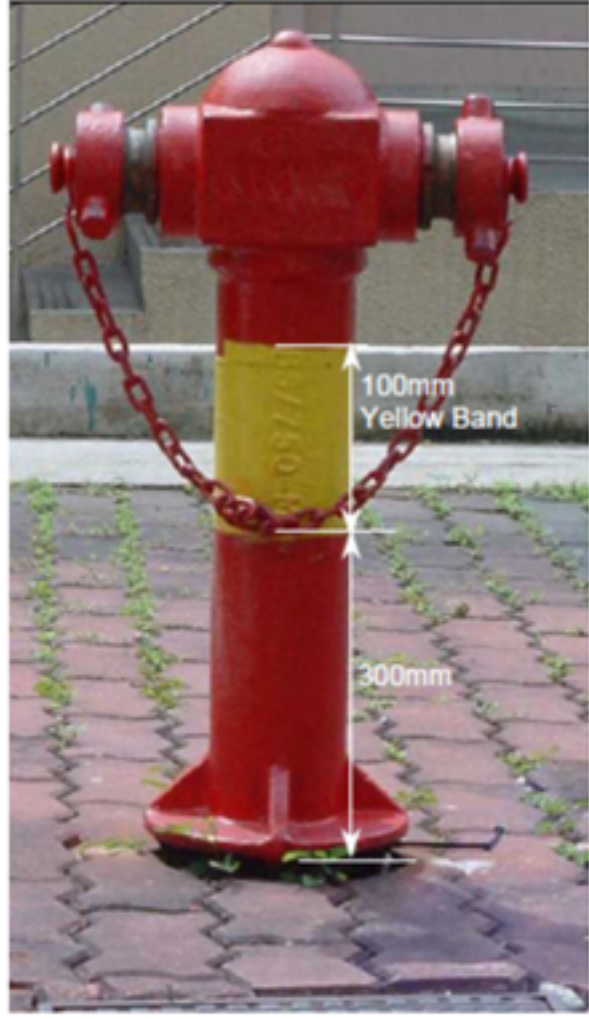

The private fire hydrant shall be painted on the stem with a 100mm yellowband and the lower edge of which is 300mm from the ground.

4.4.3 Protection of hydrant mains in stations

Rationale

Hydrant mains supplying water to hydrant(s) shall be appropriately protected to prevent any damage from fire or the carrying out of addition/alteration works within the station. The hydrant mains, if damaged would affect the firefighting operation in an emergency.

All hydrant mains which pass through a station shall have its full length within the station protected with fire resistance construction of at least the same fire resistance as the element of structure, provided all of the following requirements are complied with:

- The fire hydrant mains shall be located in common circulation areas, such as car parking spaces (except spaces used for mechanical car parking) and driveways, i.e. they shall not pass through private or confined spaces.
- No services other than sprinkler pipe shall be located above or crossing over the fire hydrant mains. Where services need to cross-over the hydrant mains, the following conditions shall be complied with:
 - the services shall only cross over the fire hydrants mains perpendicularly;
 - the tensile stress of the supports for the services shall not exceed 10N/mm^2 ; and
 - the services shall be adequately protected by the station's sprinkler system.
- The fire hydrant mains shall be located away from explosion risk areas.
- The protective enclosure to the fire hydrant mains shall be labelled with the words "FIRE HYDRANT MAIN" of minimum 50mm height at suitable intervals

Explanation and Illustrations

Hydrant mains where routed through stations shall be fire-rated and having at least the same fire resistance rating as the element of structure. However, they are allowed to be routed through station public areas and common circulation spaces e.g. service corridor only. No hydrant mains shall be run inside private or confined spaces such as TER or MDF rooms.

Diagram 4.2.4d.(1) – 1 to 3: CPL 34 Firefighting Appliances – Wheels & Jacks Layout

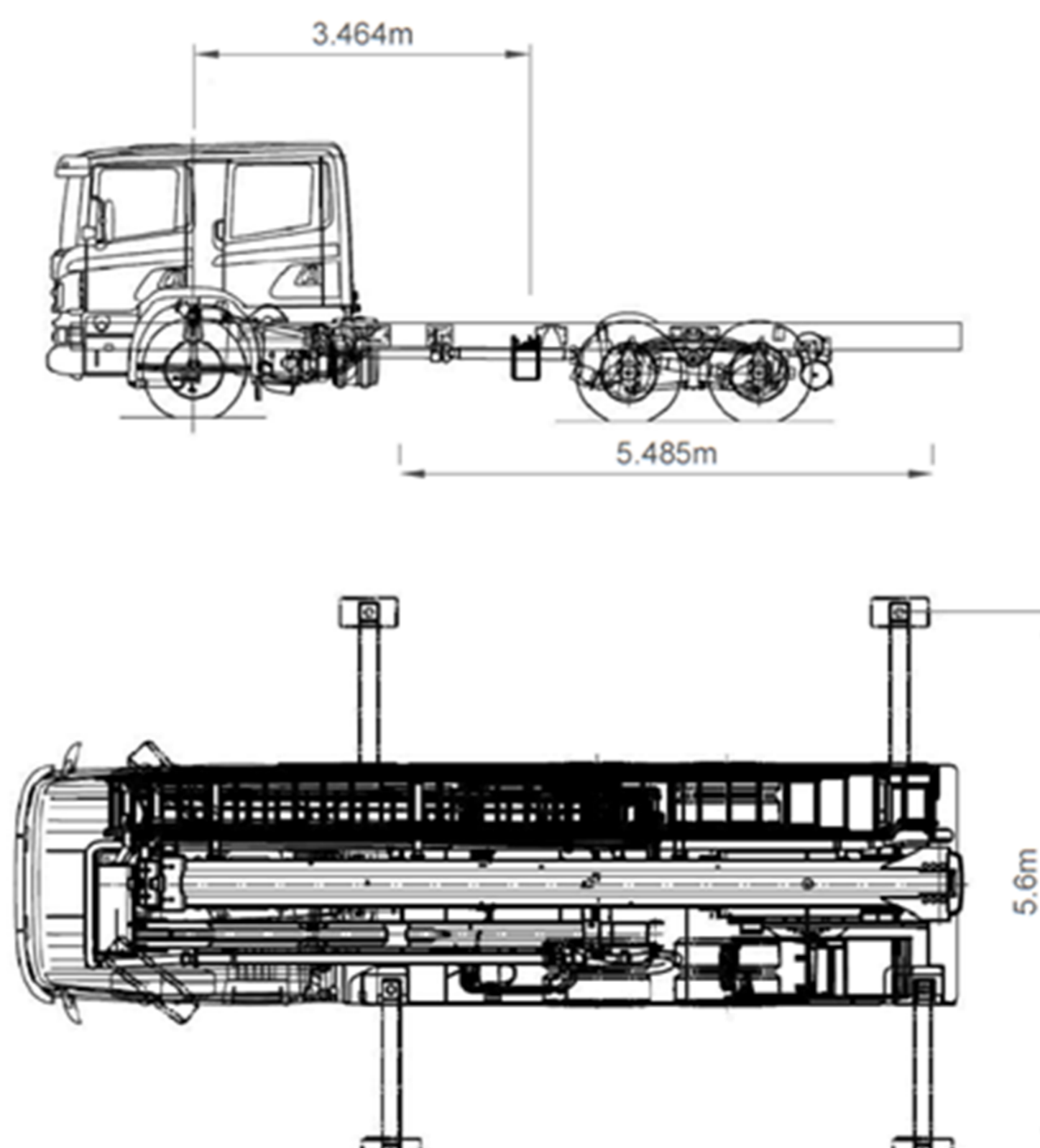

Diagram 4.2.4d.(1) – 1: CPL 34 Firefighting Appliances – Wheels & Jacks Layout

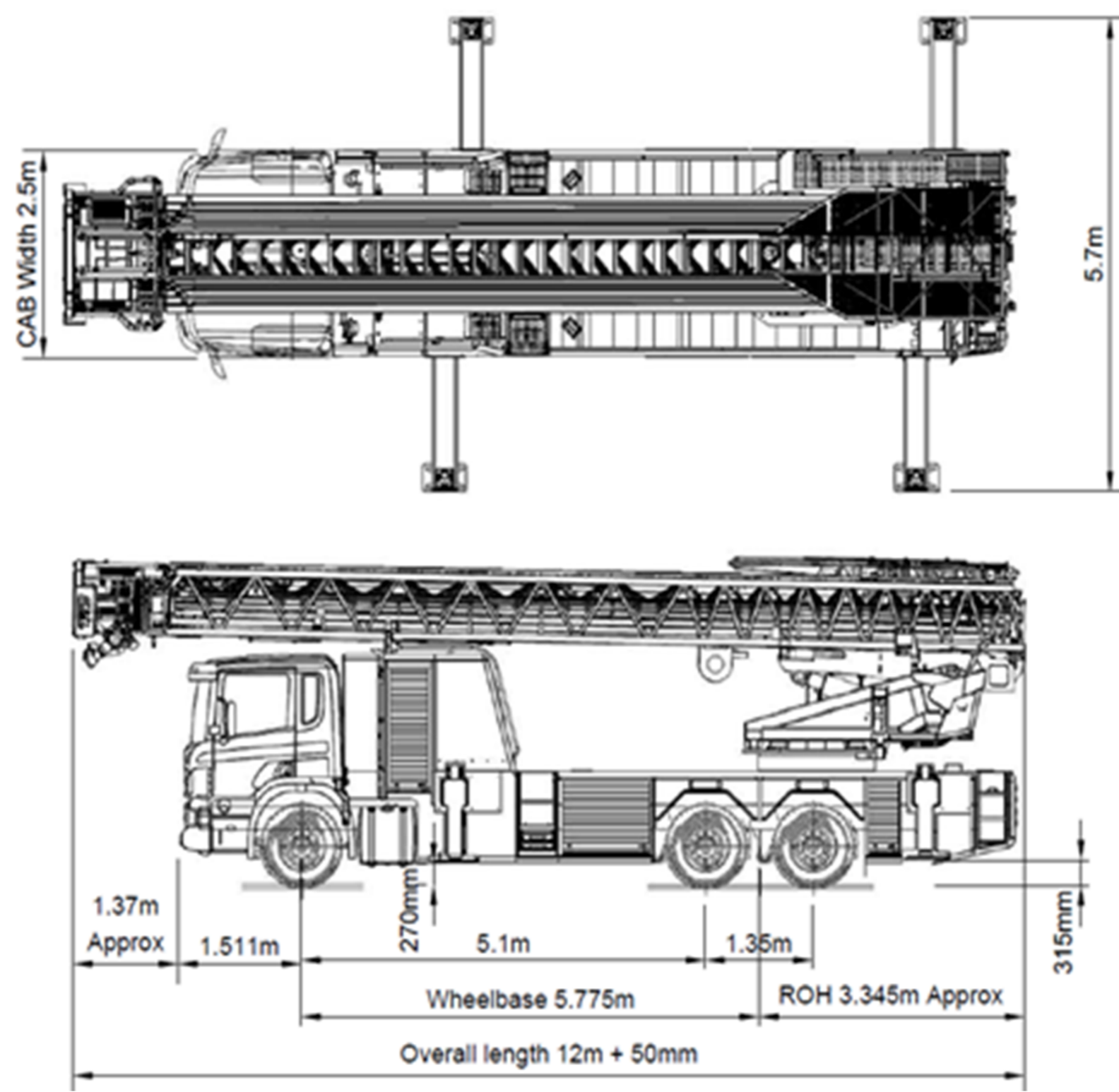

Diagram 4.2.4d.(1) – 2: AL 56 Firefighting Appliances – Wheels & Jacks Layout

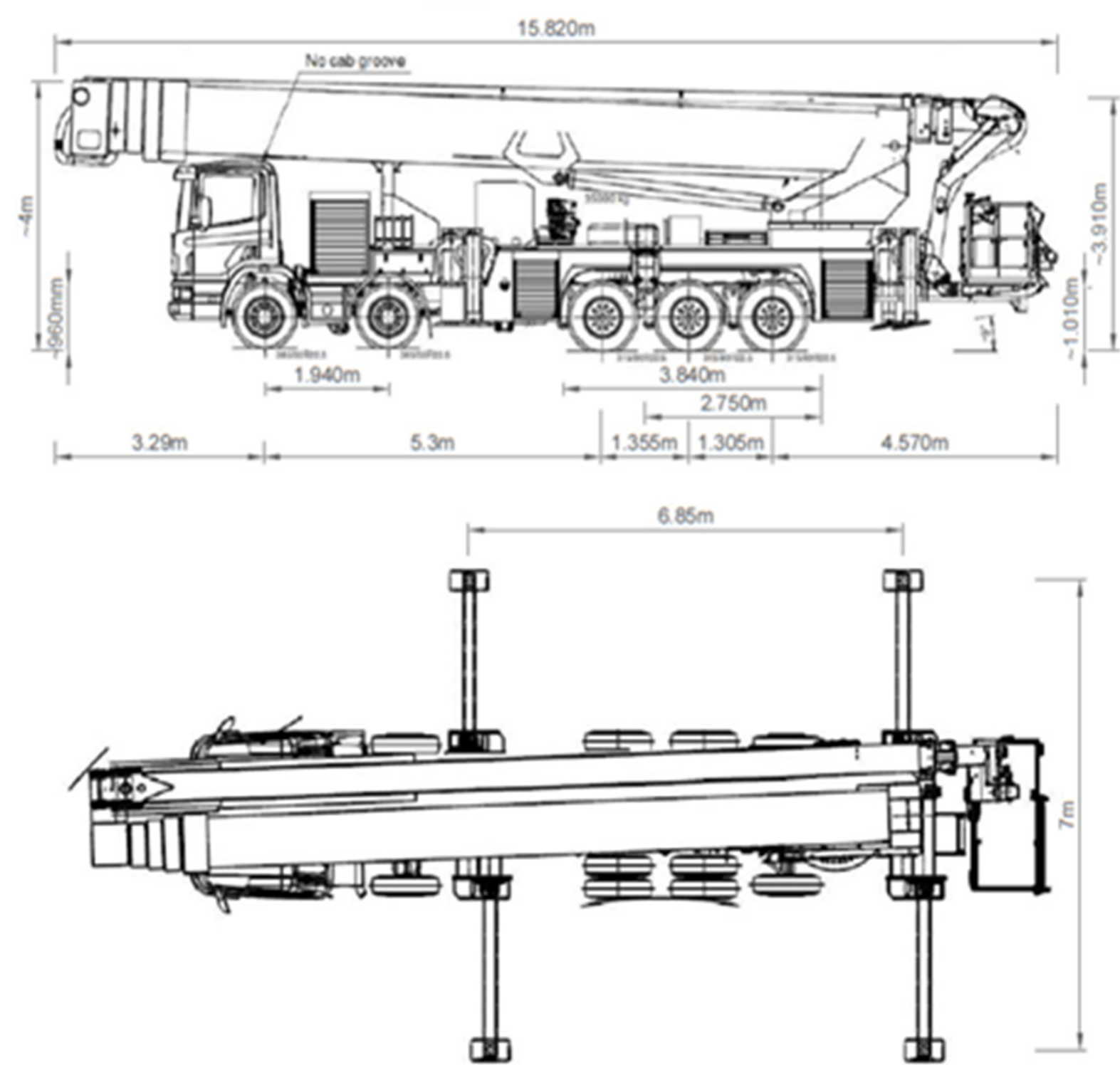
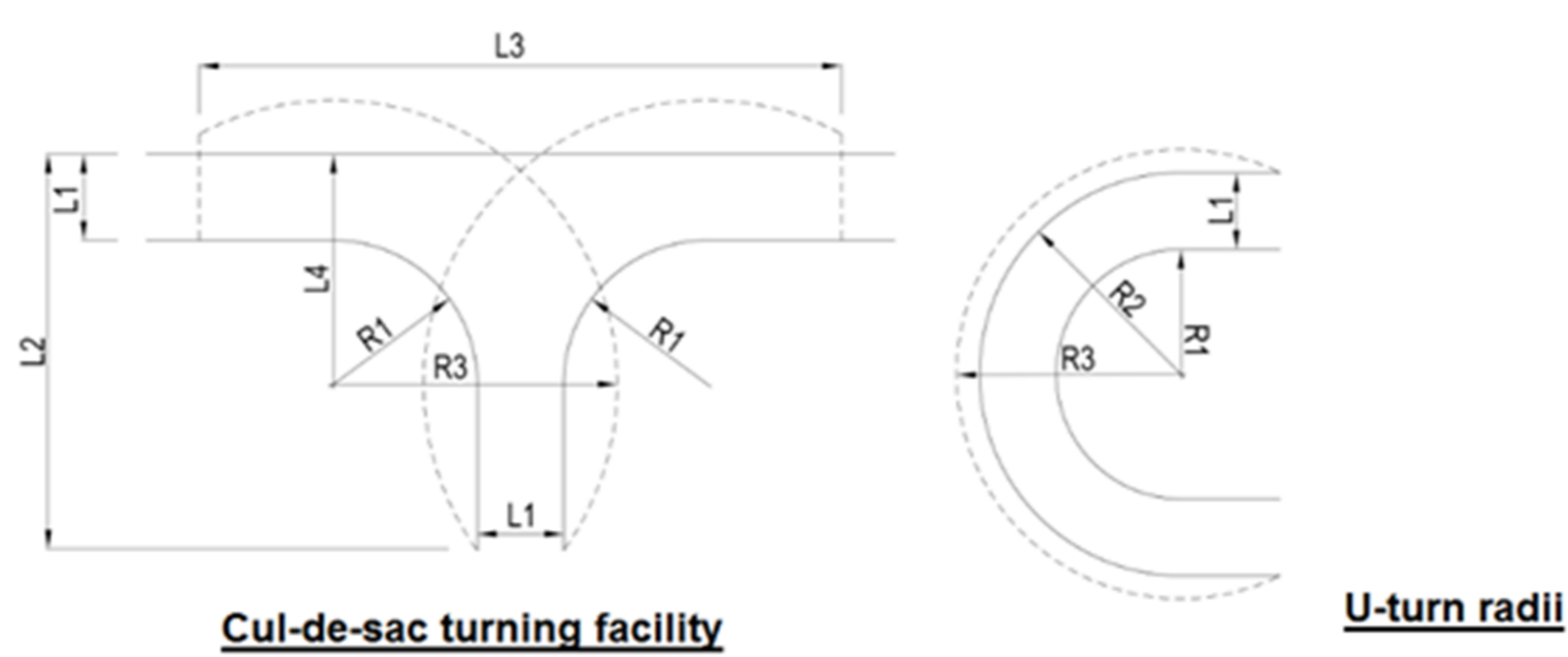

Diagram 4.2.4d.(1) – 3: HL 90 Firefighting Appliances – Wheels & Jacks Layout

Diagram 4.2.4f. – Turning Facilities for Firefighting Appliances



Dimensions of Turning Facilities for Firefighting Appliances		
Parameters	Aboveground Station Habitable Height	
	≤ 10m	> 10m
R1	4.0m	6.5m
R2	8.0m	10.5m
R3	8.5m	12.0m
L1	4.0m	4.0m
L2	11.0m	16.0m
L3	15.0m	28.1m
L4	8.0m	10.5m

Diagram 4.2.4f. – Turning Facilities for Firefighting Appliances

Diagram 4.2.4g.: Overhead Structures Over Fire Engine Accessway/ Fire Engine Access Road

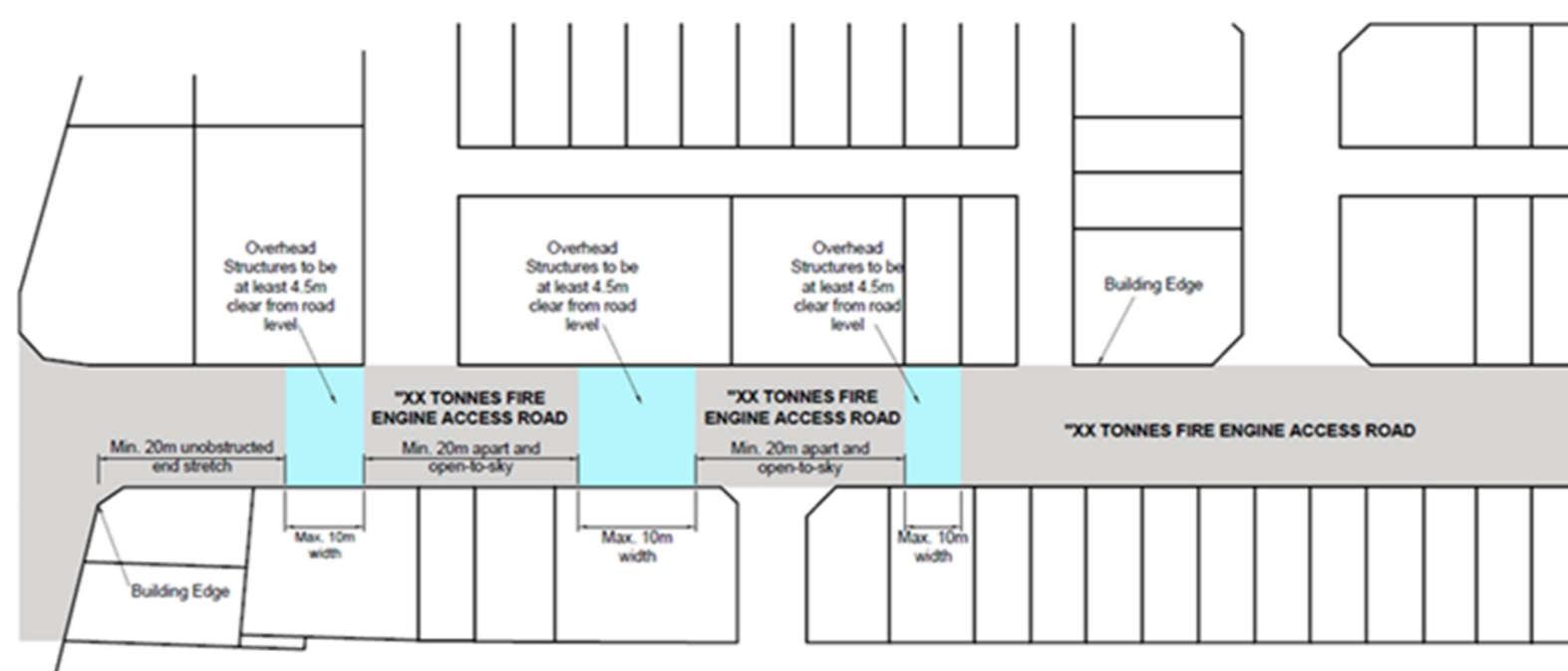

Diagram 4.2.4g.: Overhead Structures Over Fire Engine Accessway/ Fire Engine Access Road

Diagram 4.2.4j.(2): Markings for Fire Engine Accessway/ Fire Engine Access Road

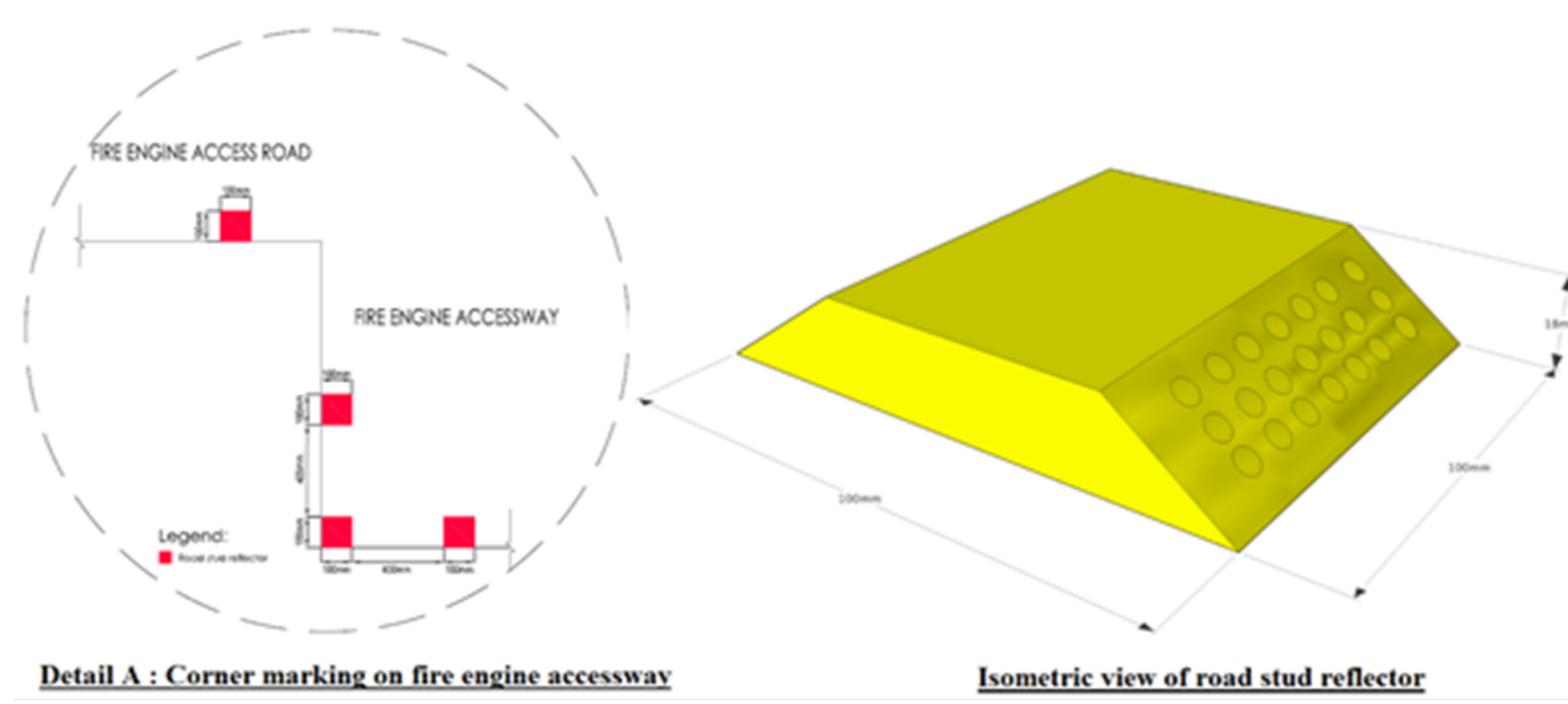

Diagram 4.2.4j(2): Markings for Fire Engine Accessway/ Fire Engine Access Road

Diagram 4.2.4j(3): Pictogram signage for Fire Engine Accessway/ Fire Engine Access Road



Diagram 4.2.4j(3): Pictogram signage for Fire Engine Accessway/ Fire Engine Access Road

Diagram 4.4.1a.: Provision of Private Fire Hydrant

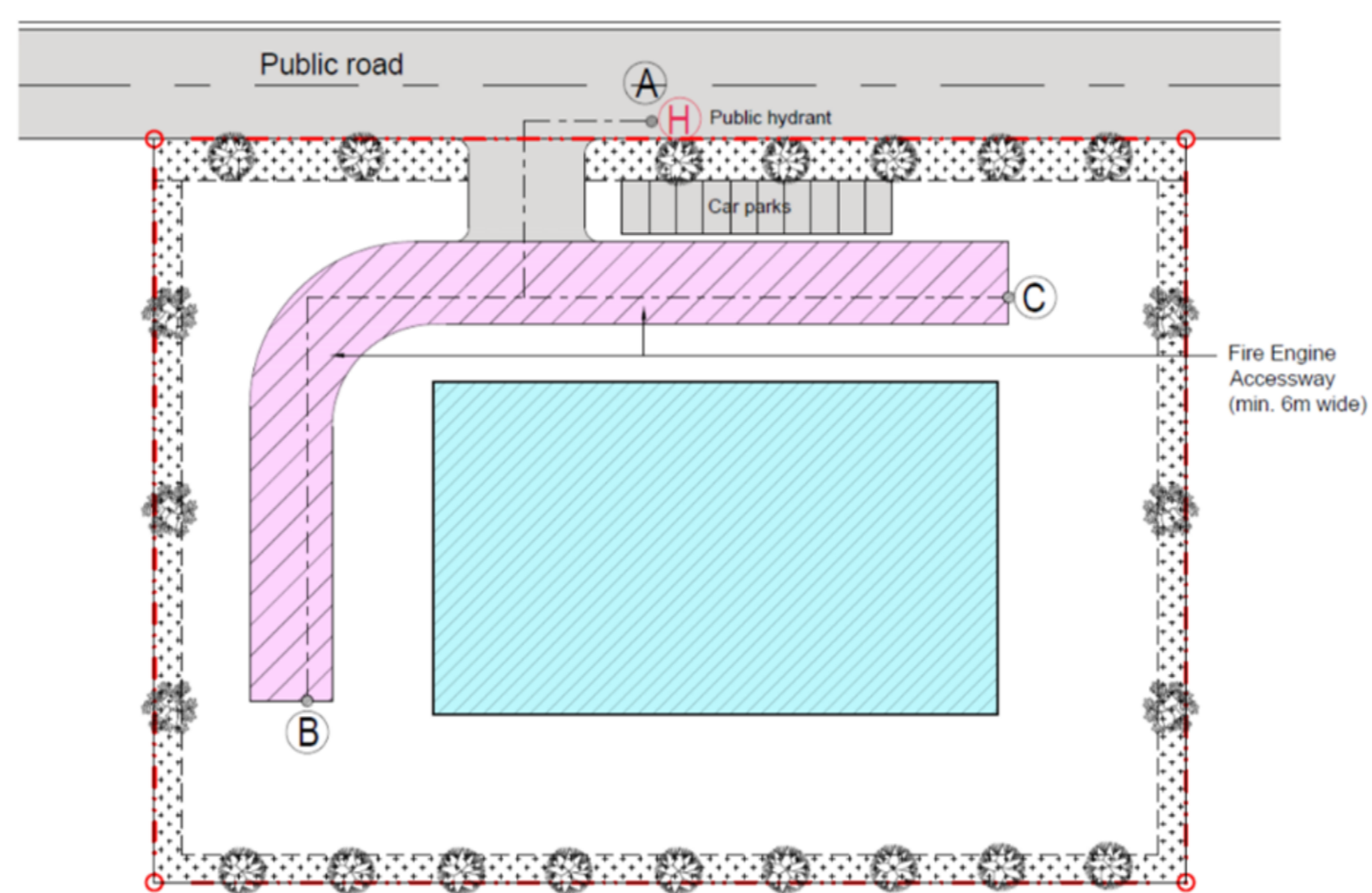

Point A to B or C \leq 50m

Every part of a fire engine accessway/ fire engine access road in a private lot shall be within an unobstructed distance of 50m from a hydrant. Where a public hydrant conforming to such requirement is not available, private hydrant(s) shall be provided.

Diagram 4.4.1a.: Provision of Private Fire Hydrant

Diagram 4.4.1c.: Siting of Private Fire Hydrant

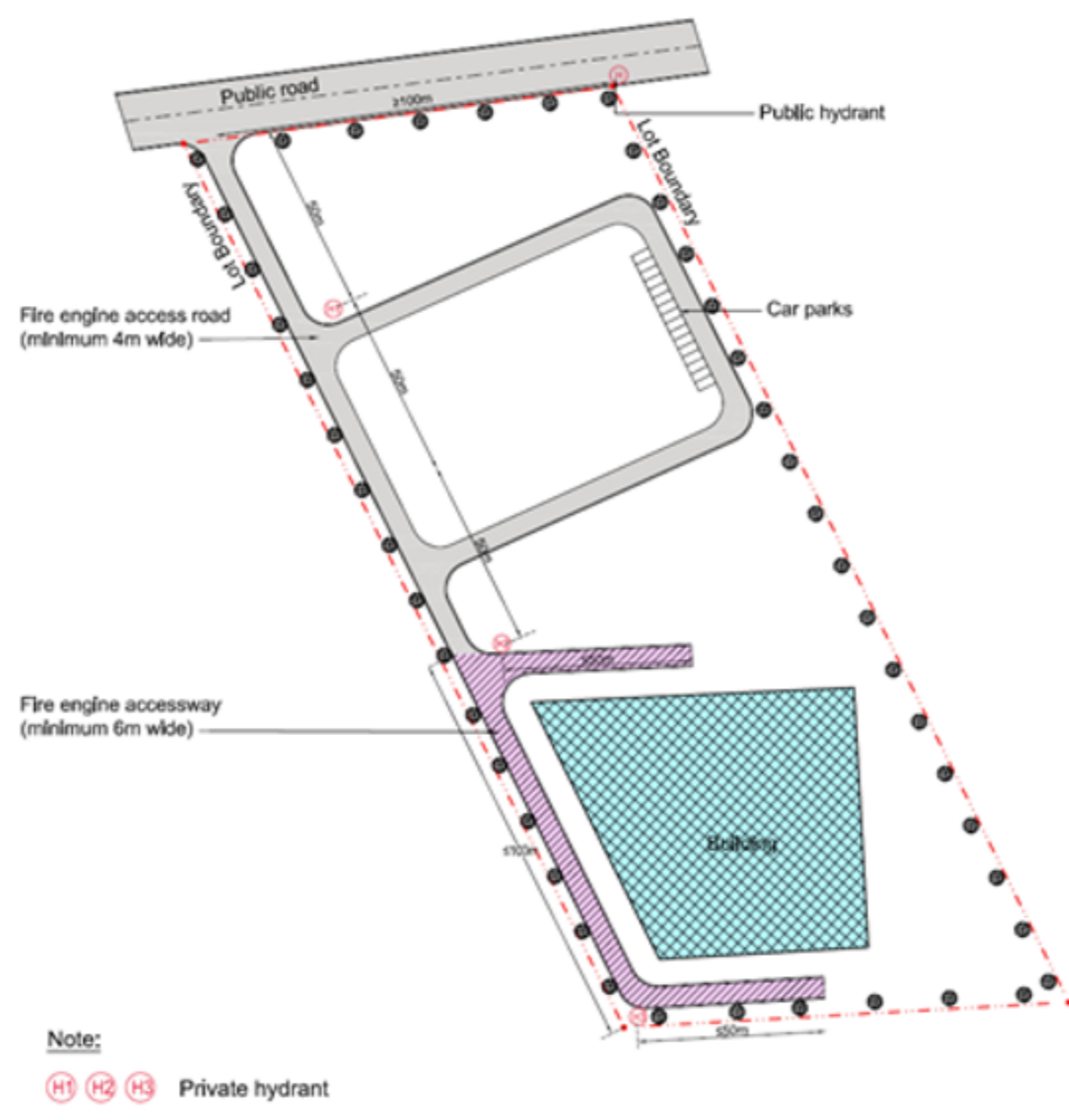

In a situation where more than one private hydrant is required, the hydrants shall be located along the fire engine accessway/ fire engine access road such that every part of the fire engine accessway/ fire engine access road is within an unobstructed distance of 50m from any hydrant.

Diagram 4.4.1c.: Siting of Private Fire Hydrant

Clause No.	Amendment Date	Effective Date	Clause Status	Clause Before Amendment	Circular Date
------------	----------------	----------------	---------------	-------------------------	---------------

CLAUSE 5.1 GENERAL

The installation, control, and distribution of wiring of electrical equipment in buildings shall be in accordance with SS CP 551 and SS 638.

CLAUSE 5.2 PRIMARY AND SECONDARY POWER SUPPLIES

5.2.1 Installations requiring primary and secondary power supplies

Where any of the following installations is required by this Code or other Codes/ Regulations, its primary and secondary source of power supply shall comply with the corresponding Code of Practice stated therein.

a. Electrical lifts

Where an electrical passenger or goods lift is required, its electrical installations, including batteries and other forms of secondary power supply, shall comply with SS 550. Where the provision of fire lift is required by this Code, installation of the primary and secondary supplies shall also comply with the above-mentioned Code of Practice.

b. Electrical fire alarm system

Where electrical fire alarm system is required, its primary power supply as well as its type and capacity of battery shall comply with SS 645.

c. Exit light and emergency lighting systems

Where exit or emergency lighting system is required, its electrical wiring, type and capacity of battery or other form of secondary power supply shall comply with SS 563.

d. Emergency voice communication system

Where an emergency voice communication system is required, its electrical wiring shall be fire-rated or otherwise fire-protected in accordance with SS 546. The appropriate type and capacity of secondary source of supply shall also be provided accordingly.

e. Fire sprinkler system

Installation of electrical supply for sprinkler systems shall comply with SS CP 52. The capacity of the secondary source of supply, where required, shall satisfy operational requirements under the respective hazard category.

f. Mechanical ventilation/ pressurisation systems

All the following systems shall be provided with secondary source of power supply:

(1) Mechanical ventilation system for the following rooms or spaces:

- (a) exit staircases;
- (b) exit passageways;
- (c) smoke-free/ fire lift lobbies;
- (d) area of refuge within the same station;
- (e) basement car parks;
- (f) fire command centres;
- (g) emergency power generator rooms;
- (h) fire pump rooms;
- (i) under-platform exhaust where required to operate during a fire emergency;
- (j) emergency ventilation system of underground or enclosed trainway; and
- (k) any other areas where such systems are installed for fire precautionary measures.

(2) Pressurisation systems for the following areas:

- (a) smoke-free/ fire lift lobbies;
- (b) internal exit staircases; and
- (c) any other areas where such systems are installed.

(3) All smoke control/ purging systems, including associated equipment forming part of the systems.

g. Air supply system for generator and fire pump

A secondary source of power supply shall be provided for the mechanical ventilation system which is installed to provide air for the operation of the following equipment:

- (1) emergency generator; and
- (2) engine driven fire pump.

5.2.2 Cable installation

The installation of cable in stations and trainways shall comply with all the following:

a. Cables used shall be either fire retardant or fire resistant. In addition, cables used in underground rapid transit systems shall be of the low-smoke and halogen-free type.

b. Fire resistant cables shall comply with SS 299 and fire-resistant fibre optic cable shall comply with IEC 60331-25.

c. Fire retardant cables shall comply with IEC 60332 Part 1 & 3 on tests on single and bunched cables under fire conditions.

d. Low-smoke and halogen-free cables shall comply with the following requirements:

(1) IEC 61034.

(2) When a sample of cable is subjected to the combustion test to determine amount of halogen acid gases (other than hydrofluoric acid) set out in IEC 60754 - Part 1, and the amount of halogen acid evolved is less than 0.5%, the cable shall be regarded as halogen free.

e. Fire resistant/ flame retardant, low smoke zero halogen (LSOH) type cables are permitted to be run exposed in air plenum, provided that:

(1) The air plenum shall be protected by fire detection system.

(2) FCU or AHU using plenum for air return and serving more than one room shall be provided with smoke detector(s) at the return air plenum or return air duct to shut down the FCU/ AHU upon detection of smoke.

5.2.3 Cables for fire safety equipment

Cables for fire safety equipment that is required to operate during a fire emergency shall be of fire-resistant type.

Exception: Internal cables of control panels/ equipment, lifts and its cables, and light fittings.

5.2.4 Electric motors and control equipment

All motors and their control equipment, as well as the associated wiring and accessories, shall be suitable for their particular application and for the environment they are exposed to. In addition, they shall comply with all the following requirements:

a. Moulded Case Circuit Breakers (MCCB) with magnetic release shall be installed and be capable of protecting the cable connections to the motor, and of carrying the stalled current of the motor for a period not less than 75% of the period for which such a current would cause the motor windings to fail;

b. any no-volt release mechanism shall be of the automatic resetting type, such that on restoration of supply the motor can start automatically;

c. thermal overload trips shall not be permitted; and

d. magnetic (short circuit) trips are permitted for use in motor circuits of mechanical ventilation systems serving essential services.

5.2.5 Emergency generator

a. Where emergency generators are provided as a secondary source of supply, they shall comply with SS 535.

b. For outdoor emergency generator, all the following requirements shall be complied with:

(1) Day tank incorporated within the body of the emergency generator shall be constructed of steel. The day tank shall be of double skin construction. The emergency generator enclosure shall be able to contain any leakage of diesel.

(2) Alternatively, an internal bund wall shall be built within the outdoor emergency generator's day tank large enough to contain 100% of the diesel content within the day tank.

(3) The maximum quantity of diesel permitted in the day tank is 1000 litres.

5.2.6 Dual electric feeder power supply

Dual electric feeder power supply is deemed to have been provided with primary and secondary source of power supplies, on condition that the feeders are tapping power supply from different

segregated blocks of the power grid. The primary feeder (primary supply) shall be the normal power supply while the secondary feeder (secondary supply) shall be the emergency power supply. See *Diagrams 5.2.6 – 1 & 2 below*.

5.2.7 Uninterruptible power supply

Uninterruptible power supply (UPS) consisting of centralised batteries can be considered as a secondary source of power supply.

Diagram 5.2.6 – 1: Block diagram of Typical RTS Station Dual Feeder LV Power Supply Scheme

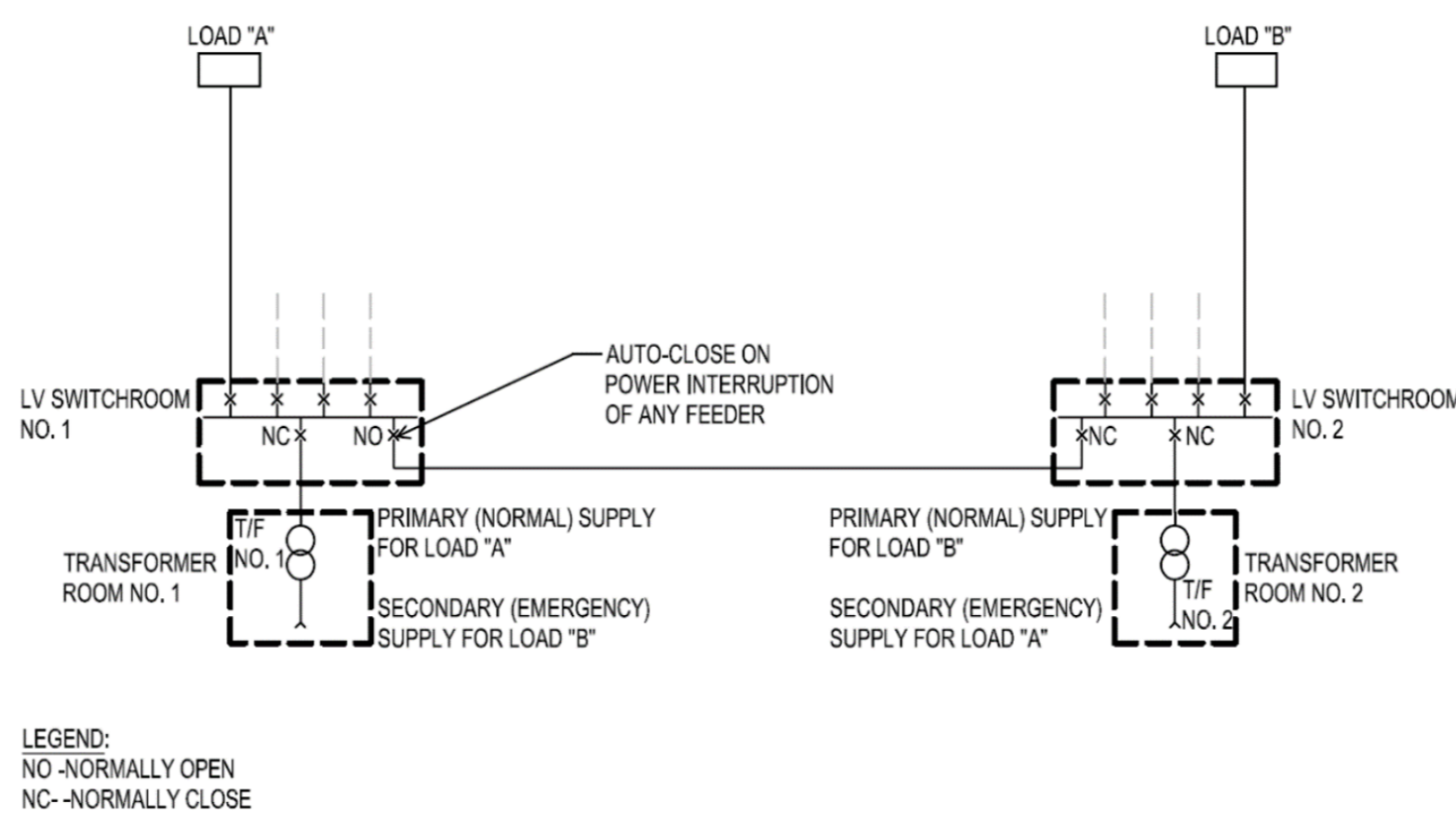

Diagram 5.2.6 – 1: Block diagram of Typical RTS Station Dual Feeder LV Power Supply Scheme

Diagram 5.2.6 – 2: Block diagram of Typical RTS Station Dual Feeder HT Power Supply Scheme

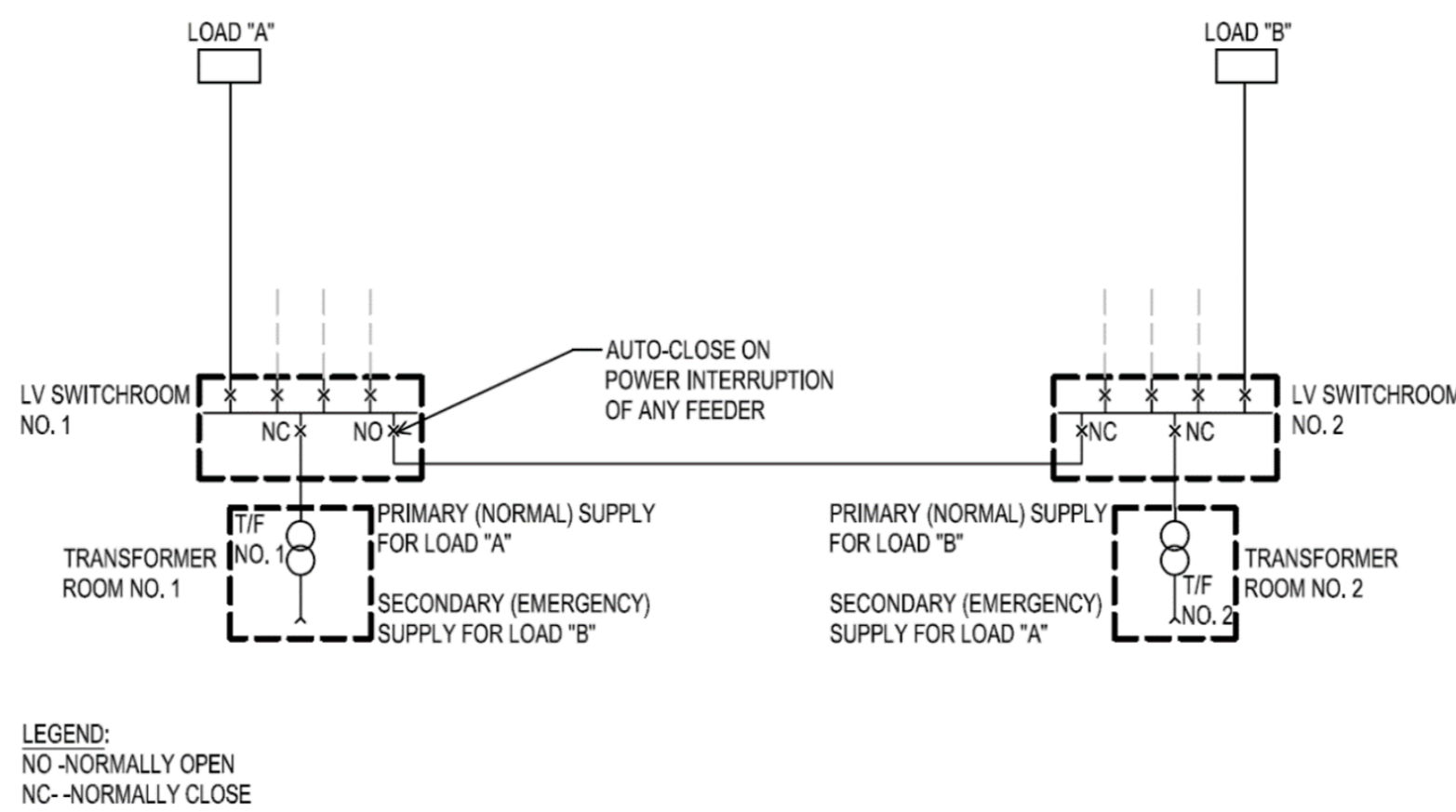

Diagram 5.2.6 – 2: Block diagram of Typical RTS Station Dual Feeder HT Power Supply Scheme

Clause No.	Amendment Date	Effective Date	Clause Status	Clause Before Amendment	Circular Date
------------	----------------	----------------	---------------	-------------------------	---------------

CLAUSE 6.1 PORTABLE EXTINGUISHERS

6.1.1 General

- a. Portable fire extinguishers, where required, shall be constructed in accordance with SS EN 3.
- b. All portable fire extinguishers, where required to be provided, shall be charged, tested, maintained, and properly tagged in accordance with SS 578.

6.1.2 Provision

- a. Fire extinguishers shall be provided within the station, commercial spaces, and plant rooms at ground level entrances except the following:
 - (1) pedestrian underground/aboveground link leading to station entrances;
 - (2) under-platform services ducts and cable chambers;
 - (3) air shafts;

Rationale

Portable fire extinguisher in the stations are meant to be used by station occupants as a first line of defence to put out incipient fires of limited size. Service ducts, such as under-platform services ducts need not be provided with fire extinguishers because the cables within such spaces are of fire resistant/ retardant type.

- (4) roof level of single storey stations/ buildings with roof height not more than 12m or inaccessible pitched roof up to 24m from grade level used solely for roof-mounted PV installations in accordance with Code of Practice for Fire Precautions in Buildings;
- (5) roof level of an external/ open-sided overhead bridge/ shed/ linkway/ walkway with clear width less than 6m, roof height not more than 12m and used solely for roof-mounted PV installations in accordance with Code of Practice for Fire Precautions in Buildings; and
- (6) Where the roof is a non-habitable floor, fire extinguishers shall be provided to cover the M&E plants/ equipment.

Explanation and Illustrations

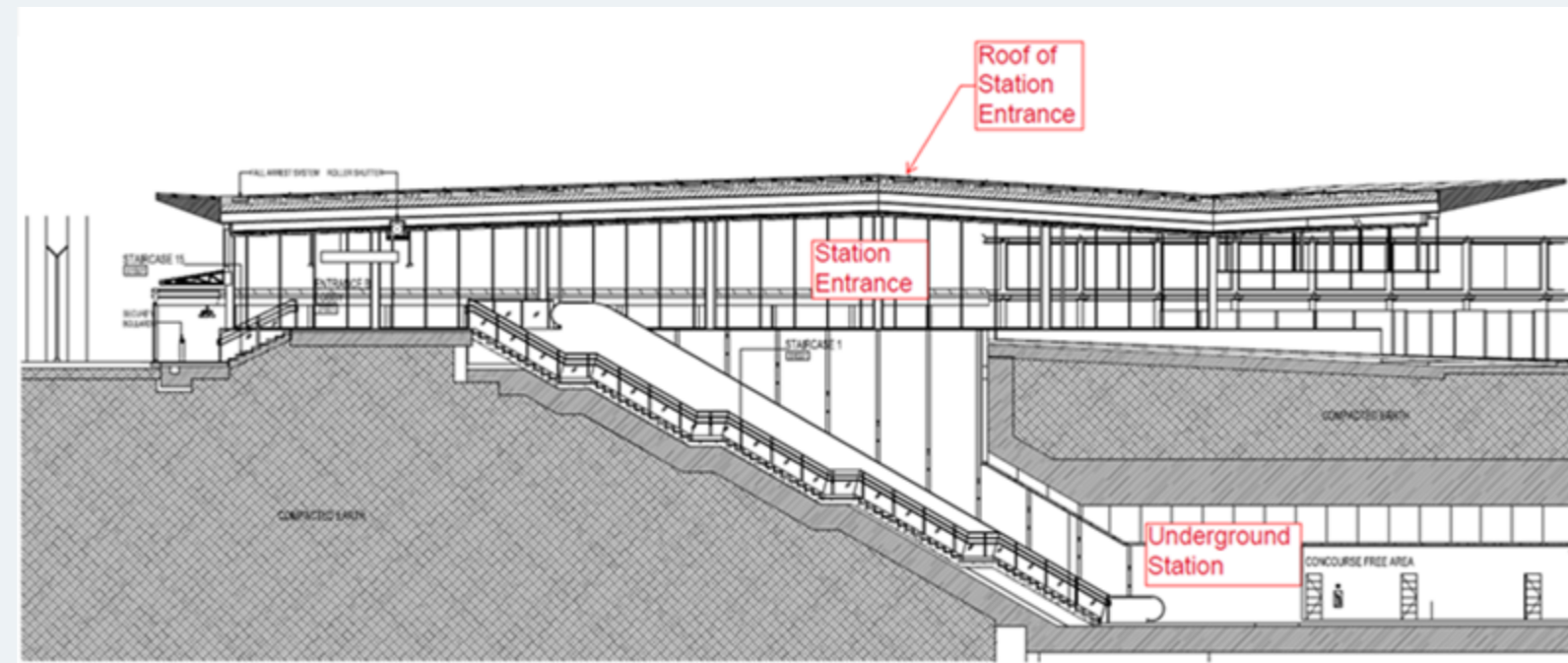

Mrt station entrance as shown is considered as single storey building.

6.1.3 Type, size, and siting

The classification of portable fire extinguishers provided shall be selected in accordance with SS 578 such that the nature of processes and contents within the building concerned can be effectively protected. The size, quantity, and siting of these portable fire extinguishers shall comply with the requirements in SS 578 under the respective class of occupancy hazard.

6.1.4 Installation and marking

Portable fire extinguishers provided shall be installed and conspicuously marked in accordance with requirements by SS 578.

CLAUSE 6.2 DRY RISING MAIN AND HOSE REEL SYSTEMS

6.2.1 Dry rising mains

a. The dry rising main system provided to the station shall be as follows:

- (1) Dry rising mains shall be installed in aboveground station where the habitable height is more than 10m.
- (2) Every basement level shall be provided with dry rising mains.
- (3) Separate dry rising mains shall be provided for the stations and underground trainways.

b. Exception

Aboveground station with all trainways located at external façade and fire engine accessway available alongside the trainways.

6.2.2 Number, location, and size of rising mains

a. Standard

The number, distribution, size, and installation of rising mains shall comply with the requirements stipulated in SS 575.

b. Provision and locations of rising mains

(1) Basement commercial spaces on commercial floors shall be provided with dry rising mains in compliance with SS 575 except as herein modified:

- (a) Landing valves shall be provided such that any part within the basement commercial spaces is within 38m (30m hose line length and a jet throw of 8m) from a landing valve, the distance to be measured along a route suitable for the hose line.
- (b) Position of landing valves shall be located in the following order of priority:
 - (i) within fire lift/ smoke-free lobby;
 - (ii) inside exit staircase; and
 - (iii) just outside the entrances of the basement commercial spaces.
- (c) Dry rising mains within the basement commercial spaces shall be at least 2-hrs fire-rated.

(2) The design of the dry rising mains in the station shall comply with requirements of SS 575 except as herein modified:

- (a) Landing valves shall be provided such that every part of each floor is within 68m (2 x 30m hose line length and a jet throw of 8m) from a landing valve along a route suitable for the hose line.
- (b) Lift motor rooms at/ near entrances, under-platform services ducts, cable chambers, electrical rooms, air locks, air plenums, vent shafts, and pedestrian subway/ bridge without commercial activities are exempted from sub-clause (a) above.
- (c) Rising mains and the associated landing valves shall be kept free of physical and visual obstruction, and be located:
 - (i) within fire lift/ smoke-free lobby;
 - (ii) inside exit staircases; and
 - (iii) where there is no fire lift lobby, smoke-free lobby or exit staircase, it shall be housed within a protected shaft near to a staircase.

Rationale

The rising mains provide ready water supply to firefighters and its landing valve shall be protected against mechanical and fire damage.

- (d) Landing valve, where provided at the station platform public area shall be charged with water when any one of the dry rising mains at the ends of the platform is charged with water.
- (e) Dry rising mains need not be fire-rated. The dry rising mains shall not be routed through smoke exhaust shafts, shops and high hazardous areas.
- (f) Each dry rising mains can serve more than two landing valves per floor provided:
 - (i) There are at least two dry rising mains, one at each end of the station;
 - (ii) The nominal bore is 150mm with a four-way breeching inlet; and
 - (iii) The total pressure loss at any landing valve is not more than 4 bars at 38l/s.

Explanation and Illustrations

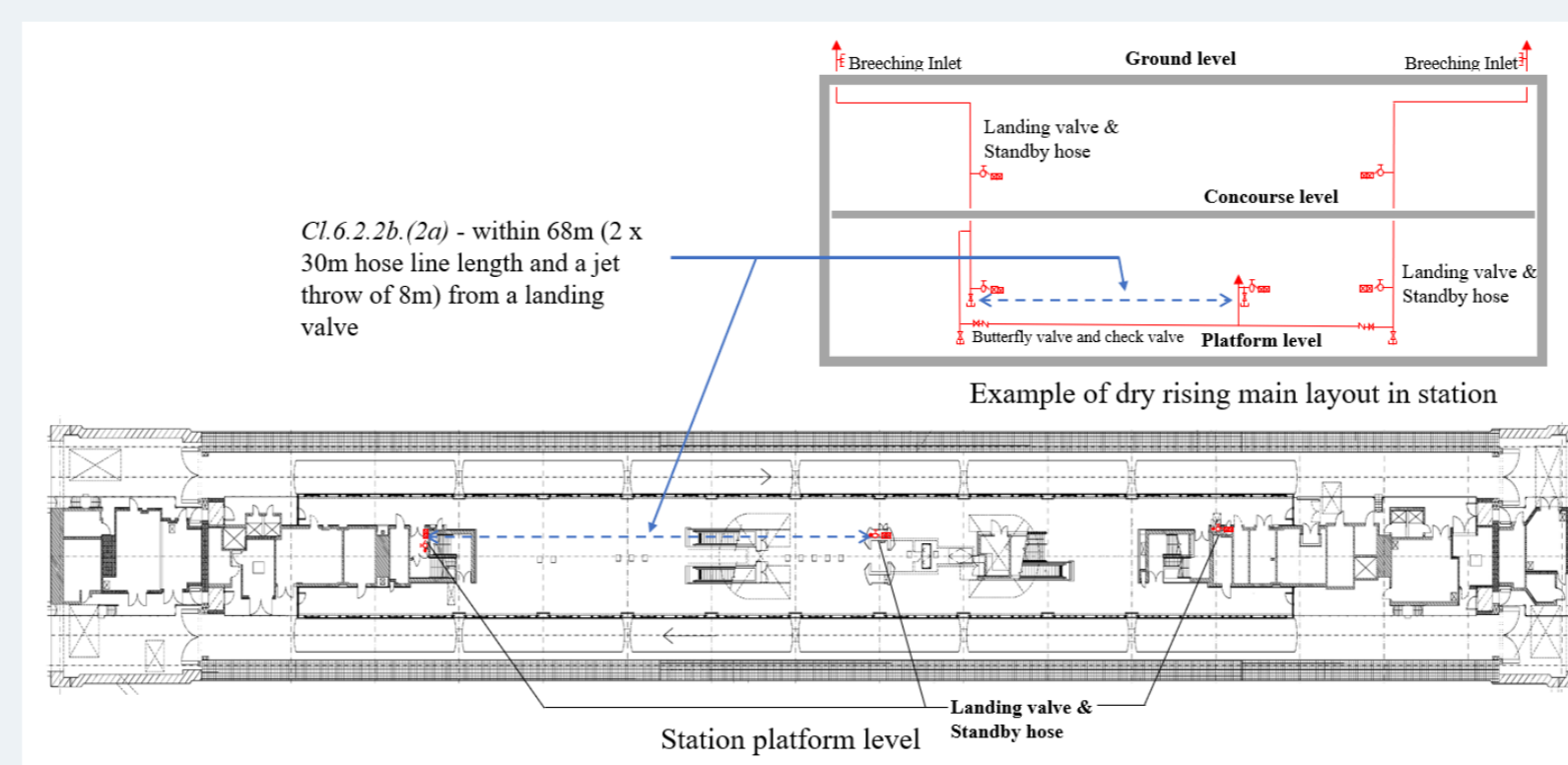

If there are part of floor exceeding 68m (along the hose line) from either landing valve in exit staircase or fire lift/ smoke-free lobby, additional landing valve shall be provided in platform public area. It shall be connected to both dry rising mains.

(g) Landing valves coverage for tunnel ventilation fan rooms shall be confined to the fans only.

(h) Access to landing valves shall not be obstructed by vehicle parking, furniture, equipment, or other materials. Where landing valve is located near to a doorway, the swing path of the door (including any grille gate/ door which could possibly be installed in the future) shall not encroach onto the swing paths of the landing valve cabinet/ protected shaft door. The swing path of grille gate/ door of units, whether to be installed or not, shall be annotated on plans. In the case where the grille gate/ door, when installed, will encroach onto more than half the width of the corridor, the QP shall annotate on the building plans that such installation is not permitted.

c. Standby fire hoses

Standby fire hose shall be provided in accordance with Cl.6.2.4. Two standby fire hoses shall be provided at each of the landing valves, but one standby fire hose is also acceptable if coverage is adequate.

Rationale

In Tunnel Ventilation Fan (TVF) room, the possible hazard is likely the fan motor, though some of these rooms can be very large. Other than the fan motor, the room is devoid of any combustible and fire hazard. As such, the coverage of landing valve, hose reel and detector need only be confined to the fan and not the entire room. This is also in cognizance that the TVF room is part of the emergency ventilation air plenum, which shall always be a restricted area. No storage, other usage and activity shall be allowed in the room.

6.2.3 Breeching inlets

a. All stations fitted with rising mains shall have a fire engine accessway/ fire engine access road for firefighting appliances within 18m of the breeching inlet. Where the breeching inlets are located at the vent shafts, the design shall be such that the firefighting operation near the breeching inlets is not affected by smoke exhausting from the vent shafts. The breeching inlets shall be visible

from the fire engine accessways/ fire engine access roads.

b. The requirements and provisions for breaching inlets for the rising main system shall be in accordance with the SS 575. Connecting pipes between the inlets and the vertical run of the rising mains, where applicable, shall be kept as short as possible.

c. The metal box for the breaching inlet need not be provided if the inlet is installed in recesses and protected from mechanical damages. A glass-fronted cover/ door complying with the requirements of SS 575 shall be provided.

d. Breaching inlets shall be appropriately numbered and labelled as shown in [Diagram 6.2.3](#). The total number of dry rising mains provided for the station (including tunnels) shall be indicated. The wording shall be white on a contrasting background.

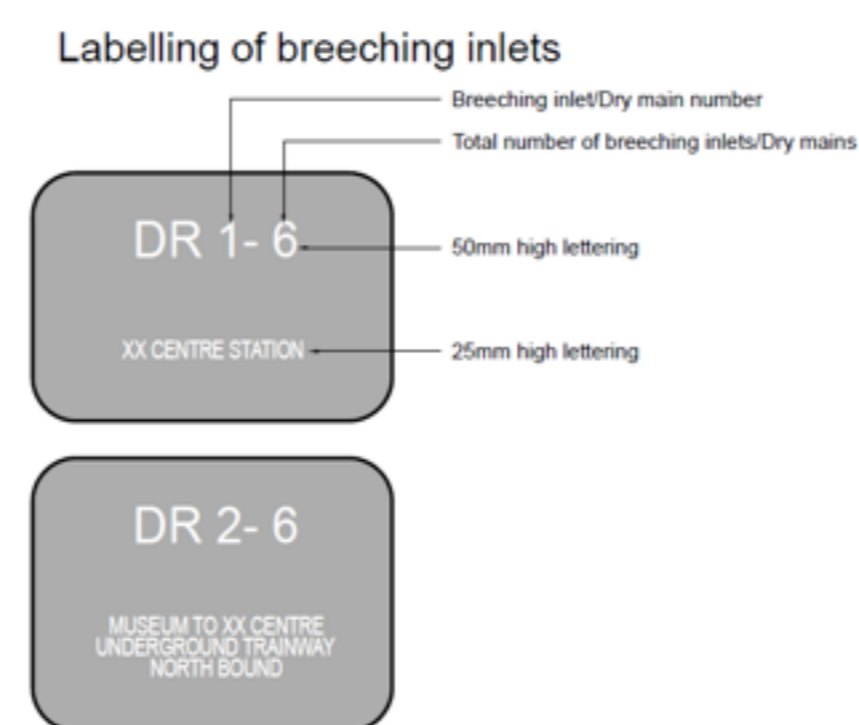

Diagram 6.2.3: Labelling of Breaching Inlets

6.2.4 Standby fire hose for rising mains

Standby fire hoses shall be provided for every rising main. The following requirements shall be complied with:

a. Type and folding method

(1) The standby fire hose shall be of 63.5mm nominal internal diameter in order to ensure that the hose coupling will fit the existing coupling tail pieces. The hose shall be rugged and capable of carrying water under substantive pressure in accordance with BS 6391. The fire hose shall be of Type 3 as stipulated in BS 6391.

(2) The fire hose couplings shall be manufactured to BS specifications or equivalent and of be light alloy or gunmetal. The coupling shall be of 63.5mm diameter and be of the instantaneous type with standard (double-pull) release mechanism. The couplings shall be secured to the hoses with galvanised mild steel wire and applied over a hose guard of synthetic fibre. It shall be able to withstand a minimum working pressure of 15 bars.

(3) Each hose shall have a standard length of 30m and shall be kept stowed in a Dutch Roll and housed in a glass fronted cabinet. The Dutch Roll shall be rolled in the manner shown in [Diagram 6.2.4c.\(9\)](#).

b. Position

(1) The fire hose shall be installed just next to, but not more than 2m from the landing valve as shown in [Diagram 6.2.4c.\(7\)](#).

(2) The entire fire hose and cabinet shall be installed away from direct sunlight.

c. Mounting

The wall mounted fire hose and cabinet shall be as follows:

(1) The cabinet shall be firmly mounted on the wall and able to withstand the weight of the hose(s) it houses.

(2) The cabinet shall be constructed of non-combustible material and be maintenance free.

(3) The cabinet lock, if provided, shall be one that can be operated manually from the inside without the use of a key when the front tempered glass (minimum 300mm x 300mm) is broken by firefighters.

(4) The cabinet swing door shall be made openable such that it will not obstruct the retrieving of the fire hose by firefighters.

(5) The depth of the cabinet shall not exceed 250mm for one fire hose or 350mm for two fire hoses.

(6) The cabinet shall be painted in a contrasting colour such that it is conspicuous and easily identified.

(7) The wording, "FIRE HOSE", with letter height of at least 50mm and shown in contrasting colour, shall be painted directly on the front panel as shown in [Diagram 6.2.4c.\(7\)](#).

(8) In lieu of the cabinet, a simple wall mounted cradle for the fire hose can be provided, but only in the riser main shaft. The cradle shall be constructed and positioned to facilitate the retrieving of fire hose by firefighters.

(9) The cradle (in lieu of the cabinet) shall be maintenance-free. The fire hose installation height shall be limited as indicated in [Diagram 6.2.4c.\(9\)](#).

d. General

(1) Only clean, dry and compactly rolled (Dutch Roll with the Velcro strap secured as shown in the [Diagram 6.2.4c.\(7\)](#) and [Diagram 6.2.4c.\(9\)](#)) hose(s) shall be placed in the cabinet.

(2) BS 6391 stipulates the technical requirements for quality acceptance standards of the fire hose. In addition, the abovementioned requirements shall be applicable for acceptance of the standby fire hose.

(3) Spare hoses

Two lengths of spare fire hoses shall be kept in stock and ready for replacement.

6.2.5 Hose reels

a. Provision

(1) Hydraulic hose reel(s) conforming to the requirements in SS 575 shall be provided throughout the stations including the commercial spaces and underground links leading to the underground station entrances except:

- (a) buffer areas (including plant rooms within these areas), station platforms and outdoor cooling tower area;
- (b) ground level entrances with no rooms/ kiosks/ ATM;
- (c) cable chambers and under-platform services ducts;
- (d) air shafts;
- (e) standalone bin centres;

Rationale

Hose reel shall not be provided at train platform because any hose reel water that is discharged acts as a good conductor of electrical currents when in contact with high voltage electrical apparatus, to cause electrocution to the person operating the hose reel.

(f) roof level of single storey stations/ buildings with roof height not more than 12m or inaccessible pitched roof up to 24m from grade level used solely for roof-mounted PV installations in accordance with Code of Practice for Fire Precautions in Buildings;

(g) roof level of an external/ open-sided overhead bridge/ shed/ linkway/ walkway with clear width less than 6m, roof height not more than 12m and used solely for roof-mounted PV installations in accordance with Code of Practice for Fire Precautions in Buildings; and

(h) green roofs which are accessible for maintenance purposes only and which comply with *Cl.10.2.1b.(1)(a)* of the Fire Code.

Explanation and Illustrations

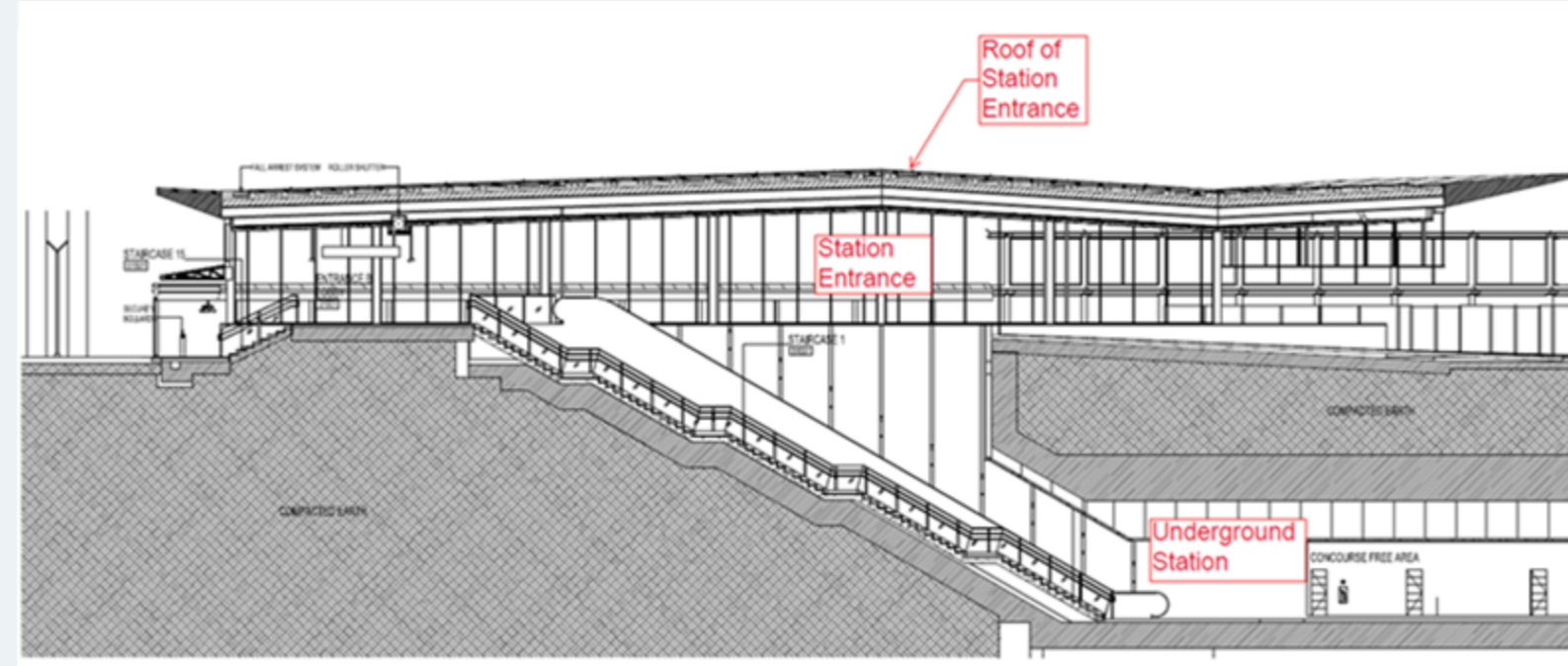

Mrt station entrance as shown is considered as single storey building.

(2) Hose reels coverage for tunnel ventilation fan rooms shall be confined to the fans only.

(3) Where a roof is a non-habitable floor, fire hose reels shall be provided to cover the M&E plants/ equipment.

b. Size and type

The hose shall be of 20mm or 25mm nominal diameter and conform to EN 694, shall not exceed 30m in length and terminate in "shut-off" branches with 4mm or 6mm nozzles.

c. Siting and installation

(1) Siting and details of installation for hose reels shall comply with the requirements in SS 575.

Rationale

In Tunnel Ventilation Fan (TVF) room, the possible hazard is likely the fan motor, though some of these rooms can be very large. Other than the fan motor, the room is devoid of any combustibles and fire hazard. As such, the coverage of landing valve, hose reel and detector need only be confined to the fan and not the entire room. This is also in cognizance that the TVF room is part of the emergency ventilation air plenum, which shall always be a restricted area. No storage, other usage and activity shall be allowed in the room.

(2) Hose reels shall be sited in prominent and accessible locations within a distance of 5m from the exit door but not inside exit staircases. If there are parts of the floor space that are beyond the 36m coverage (30m hose path and 6m throw) of the hose reel, additional hose reels shall be provided at the common area or at a distance of not more than 5m from the exit access door of a room.

(3) Hose reels located within a room shall not be used for covering the areas outside the room.

Rationale

The proximity of 5m serves to clarify the acceptable location between hose reel and exit access door or exit door.

(4) Where the hose reel and automatic sprinkler systems share the same water tank, the hose reel tap-off points shall be above the sprinkler system's reserve capacity.

d. Piping

The use of copper or stainless steel piping is permissible for the connection of the hose reels to the PUB mains.

Rationale

This is to prevent the draw-off water of the hose reel system from affecting the effective capacity required for the sprinkler system.

CLAUSE 6.3 ELECTRICAL FIRE ALARM SYSTEM

6.3.1 General

- a. An automatic fire alarm system shall be provided in the station
- b. The fire alarm system shall comply with the requirements of the SS 645 except as herein modified:
 - (1) Buffer area, air lock, air plenum, air shafts, above ground outdoor cooling tower enclosure and naturally cross-ventilated public areas need not be provided with detectors. The detector for tunnel ventilation fan room shall be confined to the fans only.
 - (2) Alarm bells in the commercial spaces on the commercial floor shall only sound if sprinklers, detectors, or manual call points are activated within the commercial spaces.
 - (3) In addition to the alarm bells, sufficient visual alarm devices e.g. strobe lights shall be provided in but not limited to the following plant rooms where the background noise is excessive:
 - (a) Environment control system plant room;
 - (b) Tunnel ventilation fan room;
 - (c) Under-platform exhaust fan room;
 - (d) Smoke extract fan room;
 - (e) CD generator room; and
 - (f) CD cooling tower room.

Rationale

In Tunnel Ventilation Fan (TVF) room, the possible hazard is likely the fan motor, though some of these rooms can be very large. Other than the fan motor, the room is devoid of any combustible and fire hazard. As such, the coverage of landing valve, hose reel and detector need only be confined to the fan and not the entire room. This is also in cognizance that the TVF room is part of the emergency ventilation air plenum, which shall always be a restricted area. No storage, other usage and activity shall be allowed in the room.

- (4) For fire detection in the station's back of house electrical rooms, service duct/ cable duct/ under-platform, associated cable basement and concealed ceiling spaces of public areas, linear heat detectors of the optic fibre type are allowed. Where linear heat detectors are used, the coverage shall be equivalent to the point-type detectors. For fire detection under the ceilings of station public areas, optical beam line-type detectors are allowed.
- (5) The following areas are exempted from automatic fire alarm protection:
 - (a) External open-sided linkways not exceeding 6m in width measured from eave to eave, provided these areas are not for commercial activities or storage;
 - (b) Areas which are covered with trellises, louvres or perforated panels having 50% or more evenly distributed effective free openings. An alarm sounder and visual alarm shall be provided near the exit staircase in accordance with SS 645;
 - (c) Roof level of single storey stations/ buildings with roof height not more than 12m or inaccessible pitched roof up to 24m from grade level used solely for roof-mounted PV installations in accordance with Code of Practice for Fire Precautions in Buildings; and
 - (d) Roof level of an external/ open-sided overhead bridge/ shed/ linkway/ walkway with clear width less than 6m, roof height not more than 12m and used solely for roof-mounted PV installations in accordance with Code of Practice for Fire Precautions in Buildings.

Explanation and Illustrations

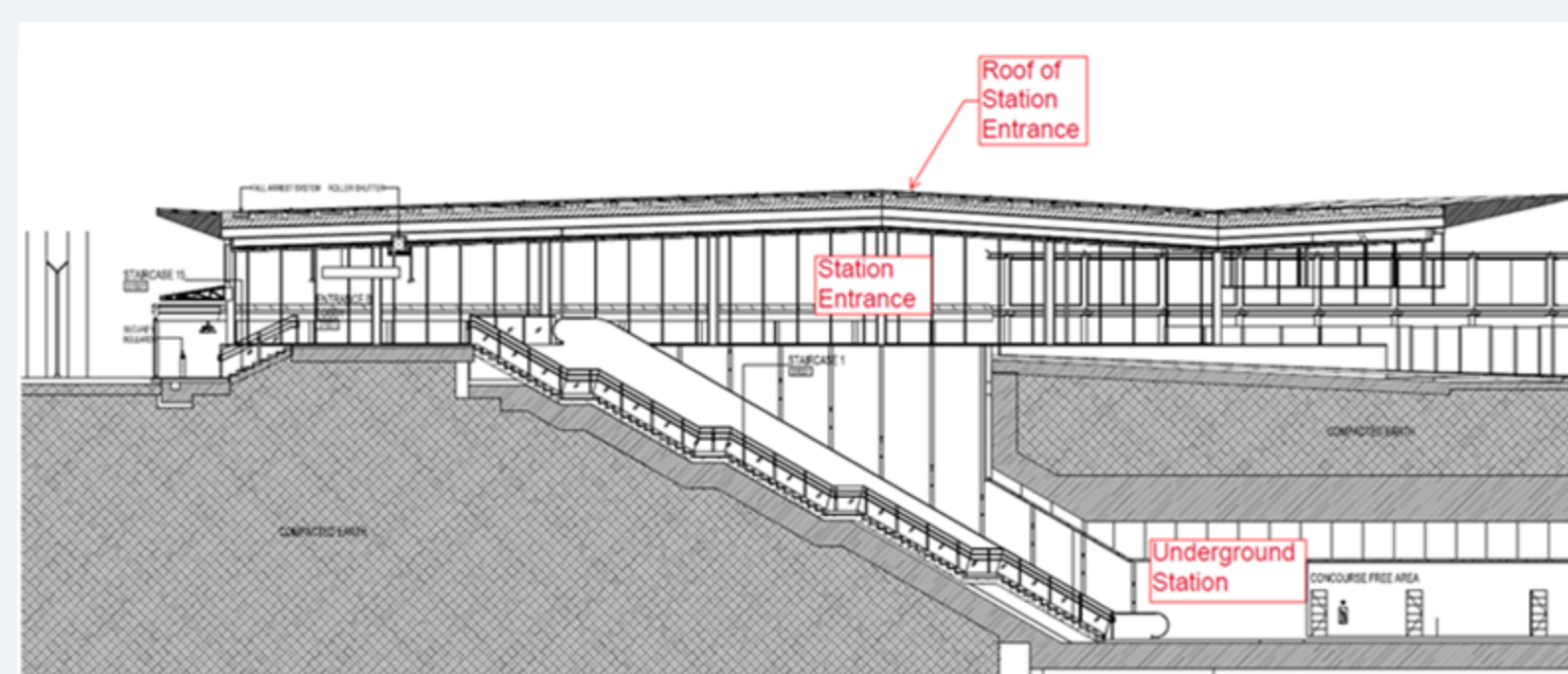

Mrt station entrance as shown is considered as single storey building

6.3.2 Fire alarm panel

- a. An electrical fire alarm system of the automatic or manual type shall be provided with a fire alarm panel to indicate the location of the alarm which has been actuated or operated. Such an alarm panel shall be accurate to the maximum allowed alarm group area limitations specified in SS 645.
- b. All automatic systems which are activated via the general station alarm shall be connected directly to the fire alarm panel.
- c. For underground stations without FCC, the main alarm panel shall be located in the firefighting staircase at ground level. All fire alarm signals shall also be transmitted to the PSC, if provided.

6.3.3 Manual alarm call points

- a. Manual alarm call points shall be provided on every storey of the ancillary area of the station and located such that no person need travel more than 30m from any position within the ancillary area to activate the alarm. Station public areas need not be provided with manual alarm call points.
- b. Manual alarm call points shall be located on exit routes preferably next to hose reels and in particular on the floor landings of exit staircases and at exits to the street. In the case where an automatic fire alarm system is provided, grouping for indication of location of the manual alarm call points shall comply with the requirements in SS 645.
- c. Manual alarm call points shall be located between 800mm and 1.2m above the finished floor level and shall be located at easily accessible and conspicuous positions free from obstructions. The installation of the sounding device shall be in accordance with SS 645.
- d. Wordings on call points shall comply with SS 508.
- e. Exemption

Manual alarm call points, alarm sounders and visual alarms can be omitted for the following:

- (1) cable chambers, under-platform services ducts, and outdoor cooling tower area;
- (2) air shafts; and
- (3) open-to-sky roof gardens/ terraces, provided an alarm sounder and a visual alarm are extended to this level and positioned near the exit staircase.

6.3.4 Alarm device

a. Audio alarm

The fire alarm sounder shall have a sound that is readily distinguishable from any other alarm systems.

b. Visual alarms

- (1) Visual alarms shall not be used in place of audible alarms and shall be provided:
 - (a) for stations protected by fire alarm systems; and
 - (b) in places, such as full-height enclosed washroom spaces, where persons with hearing impairment can be isolated, especially when they are not in their identified locations.
- (2) Visual alarms shall be located together with fire alarm sounders. Where they are not readily visible from areas accessible to persons with hearing impairment who may be in isolation, additional visual alarms shall be provided. The height of the visual alarms shall be between 2m to 3m above finished floor level.

(3) Visual alarms shall comply with all the following requirements:

- (a) They shall take the form of a flashing beacon or strobe light for use in conjunction with the conventional fire alarm system.
- (b) They shall be clearly distinguishable from any other visual indicator used in the premises.
- (c) They shall be labelled with the word "Fire" of at least 15mm in height and lettering colour shall contrast with the background.
- (d) The flashing rate shall be within 30 to 130 flashes per minute.
- (e) The visual alarm signal shall be in white or red.
- (f) The flashing of all visual alarm signals within a same space/ room shall be synchronised.
- (g) The intensity of the light signal shall be sufficient to draw the attention of people in the vicinity.

6.3.5 Connection to OCC

The electrical fire alarm system required to be installed in station under this clause shall be connected to the OCC.

6.3.6 Stations with multiple transit lines

6.3.7 Alarm signal

Separate fire alarm systems can be provided in stations with multiple transit lines in accordance with [CI.9.2.2c.](#)

A summary fire alarm signal for stations with interchange-link shall be provided in accordance with [CI.9.2.3c.](#)

6.3.8 Sprinkler-protected building/ station

Where sprinkler system is required by this Code, provision of automatic thermal/ smoke detectors in sprinkler-protected premises will be exempted except where such detectors are required to activate or operate the sprinkler or other systems.

Rationale

The use of automatic detectors is to enable smoke control system to be activated faster compared to its activation via automatic fire sprinkler system.

CLAUSE 6.4 FIRE SPRINKLER INSTALLATION

6.4.1 Provision

The following shall be provided with an automatic sprinkler system:

a. Compartment size

Whenever compartmentation requirements under [Table 3.2A of Chapter 3](#) of this Code cannot be complied with.

b. Aboveground stations

Every storey of stations of more than 24m in habitable height, regardless of whether the compartmentation requirements are complied with.

c. Basement

All basement storeys irrespective of compartment size shall be provided with an automatic sprinkler system. Where the upper storeys of the station are fully compartmented from the basement storey, the requirement for provision of an automatic sprinkler system for floors above the basement shall be considered separately.

d. Exemption

The following areas are exempted from automatic sprinkler system:

(1) Public areas. However, the public areas shall be protected in accordance with [Cl.6.3.1b](#).

(2) CD rooms not containing storage.

(3) Station Manager Room (SMR) – where SMR is adjacent to PSC, the door separating the two rooms shall be provided with a vision panel, and the door shall be provided with access management system that will release/ unlock the door automatically by fire alarm or by a manual release/ unlock device located in PSC, and portable fire extinguisher shall be provided in each room.

(4) Buffer areas.

(5) Escalator pits at entrances of multi-entry stations.

(6) Moving walk trusses (only for moving walks in an air-conditioned environment) to be free of debris.

(7) Air lock/ plenum which does not contain combustible materials.

(8) Air shaft.

(9) Areas under roof-mounted PV installations on non-habitable roof

Each sub-array of PV installation shall not exceed 5m in width, with maintenance aisle of minimum 400mm width in between the sub-arrays. Each sub-array shall be open-sided without any commercial activities or storage within these areas. The maximum dimensions of PV arrays shall be in accordance with Code of Practice for Fire Precautions in Buildings.

6.4.2 Standard

Installation of the sprinkler system and its associated water supply, control and testing requirements shall comply with the SS CP 52.

a. Hazard groups for the sprinkler design shall be as follows:

(1) Ordinary Hazard 1 for ancillary areas; and

(2) Ordinary Hazard 3 for commercial spaces.

b. Sprinkler pipes passing through the public areas and under-platform services ducts need not be enclosed within fire rated enclosures.

c. Tunnel Ventilation Fan room and Smoke Control Fan rooms which also serve as smoke plenums shall be protected by detectors.

d. Magnetic (short circuit) trips are permitted for use in motor circuits of electric motor driven pumps.

e. The sprinkler control valves and ancillary equipment shall be located in the fire pump/ tank room.

f. The flexible tube of metal construction and braided are permitted for connection to individual sprinklers and to rigid pipework above suspended ceiling and shall be of approved/ listed type.

g. Sprinklers installed in lift shafts and lift motor rooms shall be protected by stout metal guards and shall have a temperature rating of not less than 68°C.

h. Supervisory subsidiary isolation valve is allowed to be installed before and after the sprinkler pipe penetrated the wall separating main CD shelter and non-CD shelter area for CD station.

Rationale

Flexible sprinkler pipe is permitted because there is a recognised design standards that governs its design.

6.4.3 System design

a. Connection to the OCC

The sprinkler system shall be electrically monitored so that on the operation of any sprinkler head, the fire signal is automatically transmitted to the OCC via main fire alarm panel.

b. Fire pumps

Installation of fire pumps for sprinkler systems shall comply with requirements of SS CP 52. Sprinkler pumps shall be installed within a fire compartmented fire pump room, whose fire rating shall be in accordance with [Table 6.4A](#). The sprinkler pump/ control panel shall not be lower than the main floor level.

c. Location plan

A floor plan showing the locations of the sprinkler tank room, sprinkler pump room, breeching inlets and control valves shall be prominently displayed next to the main fire alarm panel.

6.4.4 Special purpose rooms

a. Where a station is required to be provided with an automatic sprinkler system under this Code, parts of the station which are used for purposes stipulated in [Table 6.4A](#) shall be compartmented in accordance with columns 3(a) and 3(b) of the table.

b. Where a station is not required to be provided with an automatic sprinkler system under this Code, special purpose rooms stipulated in [Table 6.4A](#) shall be compartmented in accordance with columns 2(a) and 2(b).

c. For the protection of controls, signalling or communication equipment rooms critical for the railway operation, if automatic sprinklers are to be replaced by an automatic fire extinguishing system, the enclosure to the hazard or occupancy shall comply with all of the following:

(1) it shall be constructed to have 1-hr fire resistance rating;

(2) any door opening shall be protected with a 1-hr fire door;

(3) it shall not be provided with more than two exits;

(4) the direct travel distance to any exit door of the enclosure shall not exceed 15m; and

(5) the fire extinguishing system shall use clean agent and shall conform to [Cl.6.5.2](#).

CLAUSE 6.5 FIXED AUTOMATIC FIRE EXTINGUISHING SYSTEMS

6.5.1 Installation

Installation of any fixed automatic fire extinguishing systems which are not deemed to be required by this Code shall not be accepted as substitute of any provision stipulated in this Code unless otherwise approved by the SCDF. Such systems will be considered additional protection for property safety and their installation shall not adversely affect the performance of the stipulated systems.

6.5.2 Design standard

The design and installation of such automatic fire extinguishing systems shall comply with corresponding codes of practice acceptable to the SCDF.

CLAUSE 6.6 LIFTS

6.6.1 General

All lift installations and operations shall comply with SS 550 except as herein modified for the lift(s) in the station used for the safe evacuation of PWD.

6.6.2 Vent openings in lift hoistway

a. The protected lift shaft shall be vented in accordance with SS 550. The vents shall be so arranged as to induce exhaust ventilation of the shaft. Where vents could not be provided because of the location of the lift shaft, ventilation duct protected by drywall complying with [Cl.3.8.8b](#), serving as ventilation of the shaft can be provided instead. If the duct is not to be fire-rated, fire dampers shall be provided to the duct at the wall of the lift shaft, provided such relaxation shall not apply to shaft containing fire lift.

b. Where the lift shaft is not a protected shaft, the lift hoistway shall be adequately ventilated at the top of the shaft by means of one or more permanent openings having a total unobstructed area of at least 0.1m² for each lift in the shaft.

6.6.3 Dual electric feeder power supply

All lifts shall be provided with the dual electric feeder to allow the lifts to continue to operate during emergency without homing.

6.6.4 Hydraulic lift

Emergency lift control during power failure and/ or fire emergency for hydraulic lifts shall also comply with [Cl.6.6.3](#) and the requirements of SS 550 respectively.

6.6.5 Connection to sub-main circuit

The power supply to the lift shall be connected to a sub-main circuit exclusive to the lift and be independent of any other main or sub-main circuits. The power cables serving the lift installation shall be routed through an area of negligible fire risk.

6.6.6 Fire lift

a. General

(1) The installation of the fire lift shall be in accordance with SS 550.

(2) All aboveground stations shall be provided with at least two fire lifts if the habitable height exceeds 24m.

(3) For underground stations where the depth between basement 1 finished floor level to the lowest storey finished floor level (cable chamber/ under-platform is not considered a storey) exceeds 9m shall be provided with at least one fire lift. All passenger lifts to double up as secondary fire lift for use by firefighters and be fitted with fire lift switches and emergency supplies.

Explanation and Illustrations

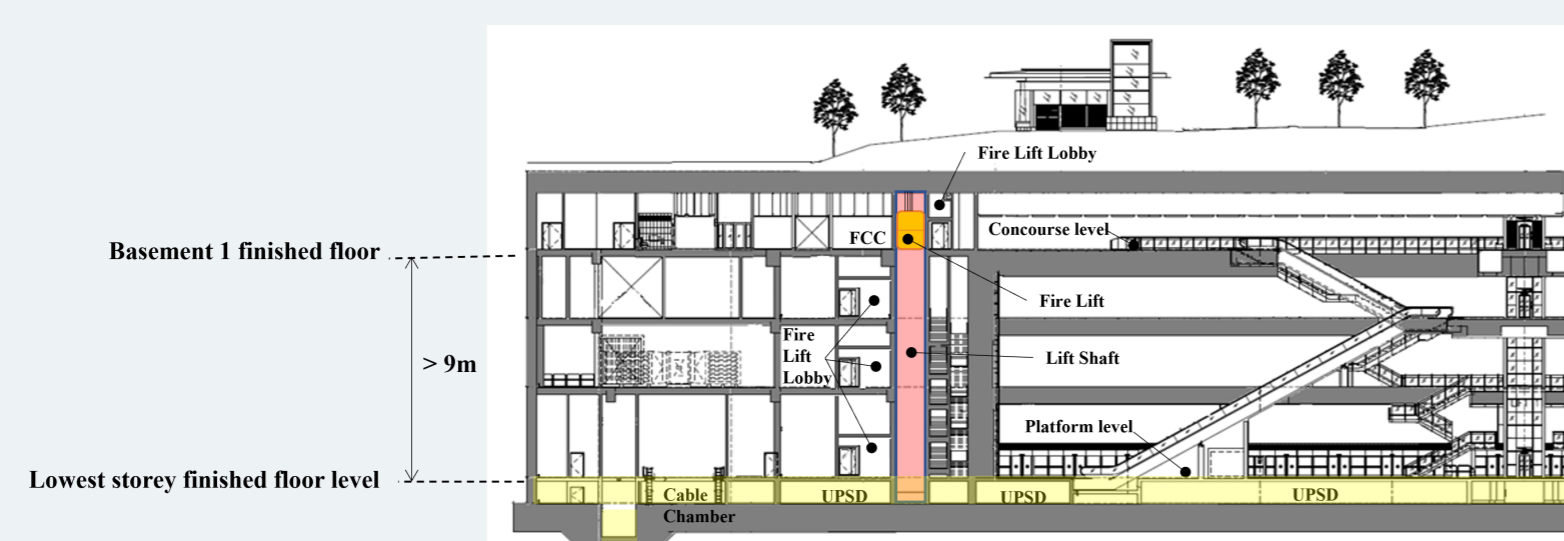

The depth is calculated from lowest storey finished floor level to basement 1 finished floor level. Cable chambers and underplatform service ducts are not considered a storey.

(4) The fire lift shall be contained within a separate protected shaft or a common protected shaft containing other lifts subject to such other lifts being served at each storey by a fire lift lobby. Basement 1 can be considered as designated firefighters entry floor if the proposed fire lift cannot be extended directly to grade without transfers. Secondary fire lift need not be contained within a separate protected shaft and being served at each storey by a fire lift lobby.

(5) The fire lift shaft shall be continuous throughout the station and serve every storey except a non-habitable roof. The fire lift operational features shall be provided and activated via a fire lift switch in accordance with SS 550 except all secondary fire lifts serving from grade level to all public areas.

Rationale

To align with Fire Code on the need for fire lifts to be based on height rather than number of storeys as future stations are getting deeper. This facilitates firefighters bringing equipment down into the station and carrying out firefighting and rescue operations.

The height can be measured from basement 1 instead of grade level to the lowest level of the station (excluding cable chamber or under-platform services ducts) for the following reasons:

a. Basement 1 is accessible via passenger lifts from multiple entrances compared with the previous situation where entrance into the basement(s) of a station is via a single firefighting lift shaft;

b. The entrances, subways and basement 1 public areas are all constructed in non-combustible materials and well-ventilated with fresh air supply being drawn in from each of the entrances; and

c. The basement 1 can be considered a safe area to reach the fire lift

(6) A lift mainly intended for the transport of goods shall not be designated as a fire lift. Cargo lift shall not open into a fire lift lobby.

(7) The fire lift car shall have a platform area of at least 1.45m². Where a fire lift serves the dual purpose of an evacuation lift for PWDs, it shall have a clear car platform area of minimum 1.2m by 1.4m.

Rationale

It is common to find goods being stacked in lobby outside good lifts. This would affect the firefighters while carrying out firefighting operations during an emergency.

b. Accessibility and coverage

(1) A fire lift shall be located such that the travel distance between the nearest edges of the lift landing door and exit staircase door is not more than 5m. In addition, the exit staircase shall be approached through a fire lift lobby at each storey, including first storey.

Exception:

(a) The final discharge of exit staircase at ground level for all stations, the travel distance between the nearest edge of the fire lift landing door and exit staircase door can be extended to at most 10m. Where the travel distance between the nearest edge of the fire lift landing door and exit staircase door exceeds 5m, additional signage shall be displayed prominently at the fire lift lobby to indicate the location of exit staircase door.

(2) Regardless of whether the station is installed with an automatic sprinkler system, the number of fire lifts required shall be such that any part of a storey of the station is within 60m coverage from the fire lift door, subject to the provision of at least two fire lifts in accordance with [Cl.6.6.6a](#), except for underground stations.

c. Fire lift switch

A fire lift switch shall be provided at both the designated and alternate designated floors.

6.6.7 Passenger lifts designated for PWDs

Passenger lifts in stations are primarily provided for use by PWDs. These lifts that are located in the public area shall be used for the evacuation of PWDs during an emergency.

a. All passenger lifts in transit stations shall be used to evacuate PWDs in the event of fire emergency.

b. Passenger lift shall have a clear platform size of at least 1.2m (width) x 1.4m (depth).

c. Where passenger lifts in transit stations are located within the public area and within one fire compartment, the lift shafts are not required to be fire-rated. It is also not required to provide fire-rated lift lobby at lift landings.

- d. From the platform level, PWDs shall use the passenger lift to reach the concourse level. Where concourse level is not the ground level, the PWDs shall be transferred to another lift that is connected to the ground level upon arrival at that concourse level. Directional signage shall be provided on the concourse level to direct PWDs to the lift(s) in accordance with the authority having jurisdiction on Accessibility in the Built Environment.
- e. In the event of fire emergency, passenger lifts are not required to home to the designated floor. Passenger lifts are to be operated as in under normal conditions for use by PWD to evacuate the station. Car call control within the lift car shall operate as per normal.
- f. Appropriate signage on the use of lift during emergency i.e. "In the Event of Emergency, Lift for Use by Persons with Disabilities Only" shall be displayed at the lift landing.
- g. Lifts in transit stations shall be provided with electrical power supply from the RTS dual-feeder electrical power supply system for uninterrupted operation during fire emergency.
- h. Except on the designated floor as defined in SS 550, emergency fire phone shall be provided at each lift landing for PWD to communicate with the Passenger Service Centre (PSC). In the absence of PSC, the emergency fire phone provided at each lift landing shall be connected to the OCC.

6.6.8 Homing of lifts

a. For stations requiring fire alarm system

- (1) In a fire emergency, when any one of the fire detection devices or fire alarm systems is activated, all lifts except passenger lifts shall be brought to the grade or designated firefighters entry floor. Otherwise, the lifts shall home to an alternate designated floor (if the designated floor is a fire floor) and park with the lift landing doors remaining opened.
- (2) Goods lifts with automatic doors shall be similarly homed to the designated floor.
- (3) Goods lifts with manual doors shall be homed if the doors are closed.

b. Requirements for alternate designated floor

- (1) An alternate designated floor (e.g. 2nd storey) shall be identified.
- (2) All lifts except passenger lifts shall be brought to the alternate designated floor in the event of a fire at the designated floor.
- (3) Localised detectors
 - (a) Localised detector(s) shall be provided to cover the lift landing space at the designated floor.
 - (b) The activation of any of the localised detector(s) or any other detectors or sprinklers covering the designated floor shall cause all the lifts to be re-directed to home to the alternate designated floor.
 - (c) The localised detector(s) shall cover the area within at least 3m surrounding the lift landing door opening.
 - (d) Where the lift landing is protected by a fire-rated enclosure, only the space within the enclosure is required to be covered by localised detector(s).
- (4) The alternate floor shall have minimum fire hazard, and where people can escape to safety in an exit staircase or other exit from the lift landing door.
- (5) In station that are not provided with sprinklers or automatic fire alarm system, suitable sensors shall be provided at the ceiling level to cover the lift landing space. The activation of any sensor shall cause the lifts to be re-directed to home to the alternate floor.

6.6.9 Provisions for lift rescue

a. General

The following requirements shall apply to station with blind lift hoist ways exceeding 11m. They shall be read in conjunction with SS 550.

b. Rescue hooks

- (1) When the distance between consecutive lift landing doorsills is more than 11m but less than 18m, as shown in [Diagram 6.6.9b\(1\) – 1](#), rescue hooks complying with [Cl.6.6.9b\(3\)](#) shall be provided at the underside of the upper lift landing door head. See [Diagram 6.6.9b\(1\) – 2](#).
- (2) Alternatively, these hooks shall be installed in the ceiling space directly above the upper lift landing door, such that the heights of these hooks are not more than 3m above the finished floor level of that upper lift landing, and at an approximate distance of 1m away from the lift shaft wall. The ceiling space shall be easily accessible, and a sign shall be provided to indicate the locations of the rescue hooks. See [Diagram 6.6.9b\(2\) – 1 & 2](#).

(3) Rescue hook design

Each rescue hook shall have pull-out strength of at least 1000kg (10kN) and a thickness of at most 14mm in diameter. The clear space between the hook and the emergency door frame shall not be less than 100mm, and the spacing between the two hooks shall be between 500 to 700mm. See [Diagram 6.6.9b\(3\)](#).

c. Landing emergency doors

(1) Where the distance between consecutive lift landing doorsills exceeds 18m, intermediate landing emergency doors shall be provided, such that the distance between sills is at most 18m. However, for adjacent cars fitted with car emergency doors complying with [Cl.6.6.7d](#), intermediate landing emergency doors are not required.

(2) The landing emergency doors shall conform to all the following requirements. See [Diagram 6.6.7c\(2\)](#):

- (a) The dimension of landing emergency doors shall comply with the requirements of SS 550.
- (b) They shall be easily accessible and free from fixed obstructions.
- (c) They shall be either of the horizontally sliding or swinging single-leaf type.
- (d) They shall be self-closing and self-locking and shall be marked in letters not less than 50mm high: "DANGER, LIFT WELL".
- (e) They shall be provided with a landing door lock which can be unlocked only from the landing side through the use of a key. The lock shall not be unlocked by any key which will open any other lock or device used for any other purpose in the building/ station. The key shall be kept where it is accessible only to authorised persons.
- (f) Each door shall be provided with an electrical contact, the opening of which will render the lift inoperable.
- (g) Two rescue hooks complying with Cl.6.6.7b(3) shall be provided at the underside of each emergency door head. Alternatively, these hooks can also be installed in the ceiling space as stipulated under Cl.6.6.7b(2).

d. Car emergency doors

- (1) When car emergency doors are provided in adjacent cars to permit the lift-to-lift rescue and evacuation of passengers, there is no limit on the maximum allowable length of the blind lift hoist way. See [Diagram 6.6.9d\(1\)](#).
- (2) When car emergency doors are provided, all of the following requirements shall be complied with. See [Diagram 6.6.9d\(2\)](#):
 - (a) The horizontal distance between cars shall comply with the requirements of SS 550.
 - (b) The dimension of car emergency doors shall comply with the requirements of SS 550.
 - (c) Car emergency doors shall be openable from outside the car without a key and from inside the car using a key.
 - (d) Car emergency doors shall open towards the inside of the car.
 - (e) Car emergency doors shall not be located in the path of a counterweight or in front of a fixed obstacle (except for beams separating the cars) preventing passage from one car to another.
 - (f) A portable/ movable bridge or a bridge integrated into the car complying with the requirements of SS 550 shall be provided.
 - (g) Each car emergency door shall be provided with an electric safety device, the opening of which will render the lift inoperable. A safety feature to prevent the lift from operating when the bridging plate or the handrail is deployed shall also be provided.

CLAUSE 6.7 COLOUR SCHEME OF FIRE PROTECTION SYSTEMS

6.7.1 Equipment, fixtures, and fittings

The following equipment, fixtures, and fittings for the fire protection systems shall be painted in red. For those equipment, fixtures, and fittings not listed below, the colour scheme shall be in accordance with that specified in the relevant codes of practice.

a. Fire sprinkler system

- (1) Fire pump & control panel
- (2) Breeching inlet (excluding breeching inlet cabinet/ enclosure)
- (3) Sprinkler control valve
- (4) Sprinkler water proofing system/device

b. Electrical fire alarm system

- (1) Main fire alarm panel/ cabinet
 - (2) Sub fire alarm panel/ cabinet
 - (3) Manual alarm call point
 - (4) Visual alarm light housing
- (Note: fire alarm bell need not be in red)

c. Private fire hydrant

- (1) Wet pillar hydrant (with yellow band in accordance with SS 575)
- (2) Dry pillar hydrant (whole hydrant in yellow)

d. Dry rising mains

- (1) Fire pump & control panel
- (2) Breeching inlet (excluding breeching inlet cabinet/ enclosure)
- (3) Dry riser breeching inlet in yellow
- (4) Landing valve (except dry landing valve to be in yellow)
- (5) Rising mains pipe
- (6) Standby hose cabinet/ enclosure

e. Hose reel system

- (1) Hose reel pump & control panel
- (2) Hose reel drum (excluding cabinet/enclosure)

f. Total flooding fire extinguishing system

Breathing apparatus cabinet/ enclosure

g. Emergency Voice Communication System

Handset/ cabinet/ enclosure

h. Fire extinguisher

Housing cabinet/ enclosure

(Note: Alternatively, red graphic signage or red wordings "Fire Extinguisher" of minimum size 20mm shall be provided.)

6.7.2 Pipework, conduits, trunkings, and cable trays

For fire protection systems pipework/ conduits/ trunkings/ cable trays which are not required to be painted in red, red colour bands of width not less than 20mm and labelling shall be provided at an interval of not more than 6m apart.

6.7.3 Graphical symbols

Graphical symbols to depict fire safety equipment are allowed for use in stations provided the signs comply with SS 508. Either graphic or text format can be used for the design of the signage. [Table 6.7.3](#) shows the different sizes of the graphical symbol with respect to the viewing distance.

CLAUSE 6.8 REDUNDANCY FOR FIRE PUMPING SYSTEM

The pumping system for hose reels, sprinklers and hydrants shall be provided with redundancy such that the system performance is not affected when one of the pumps and/ or the associated control system is out of operation due to routine maintenance or break-down.

TABLE 6.7.3: SIZES OF GRAPHICAL SYMBOLS

TABLE 6.7.3: SIZES OF GRAPHICAL SYMBOLS				
Viewing Distance	0 to 6m	> 6 to 9m	> 9 to 12m	12m or more
Minimum height of symbol (Z=100)	60mm	90mm	120mm	150mm

Note:
The luminous factor (Z=100) from SS 563 is used to determine the size of the sign. It essentially dictates the size of the sign that varies with distance. The graphical symbol for firefighting equipment shall be sized such that the height and width are same. The size of symbol is not inclusive of borders.

Diagram 6.2.4c.(7): Dutch-rolled Fire Hose with Cabinet (Surface-mounted or Recessed)

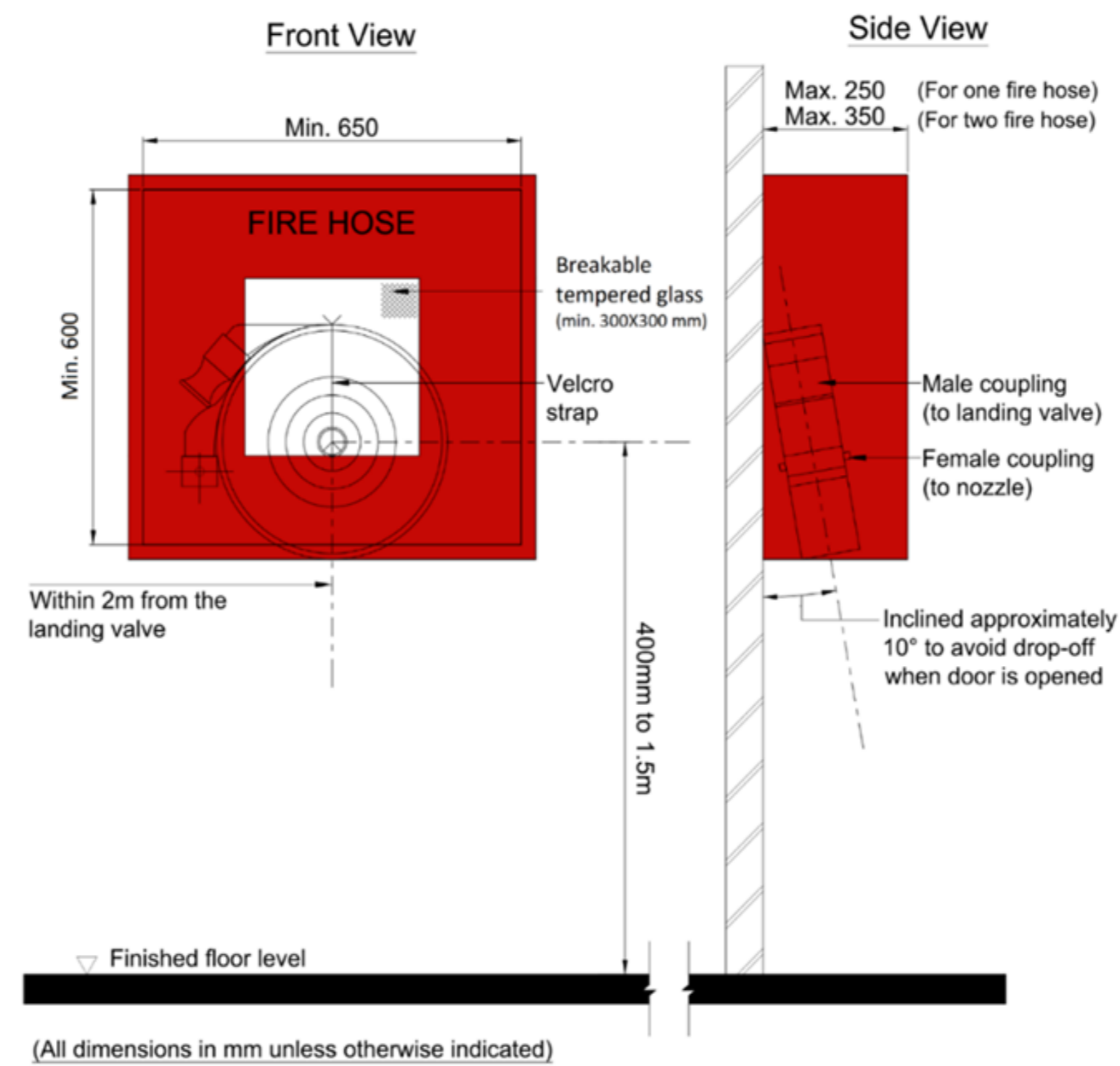

Diagram 6.2.4c.(7): Dutch-rolled Fire Hose with Cabinet (Surface-mounted or Recessed)

Diagram 6.2.4c.(9): Dutch Roll Folding Method

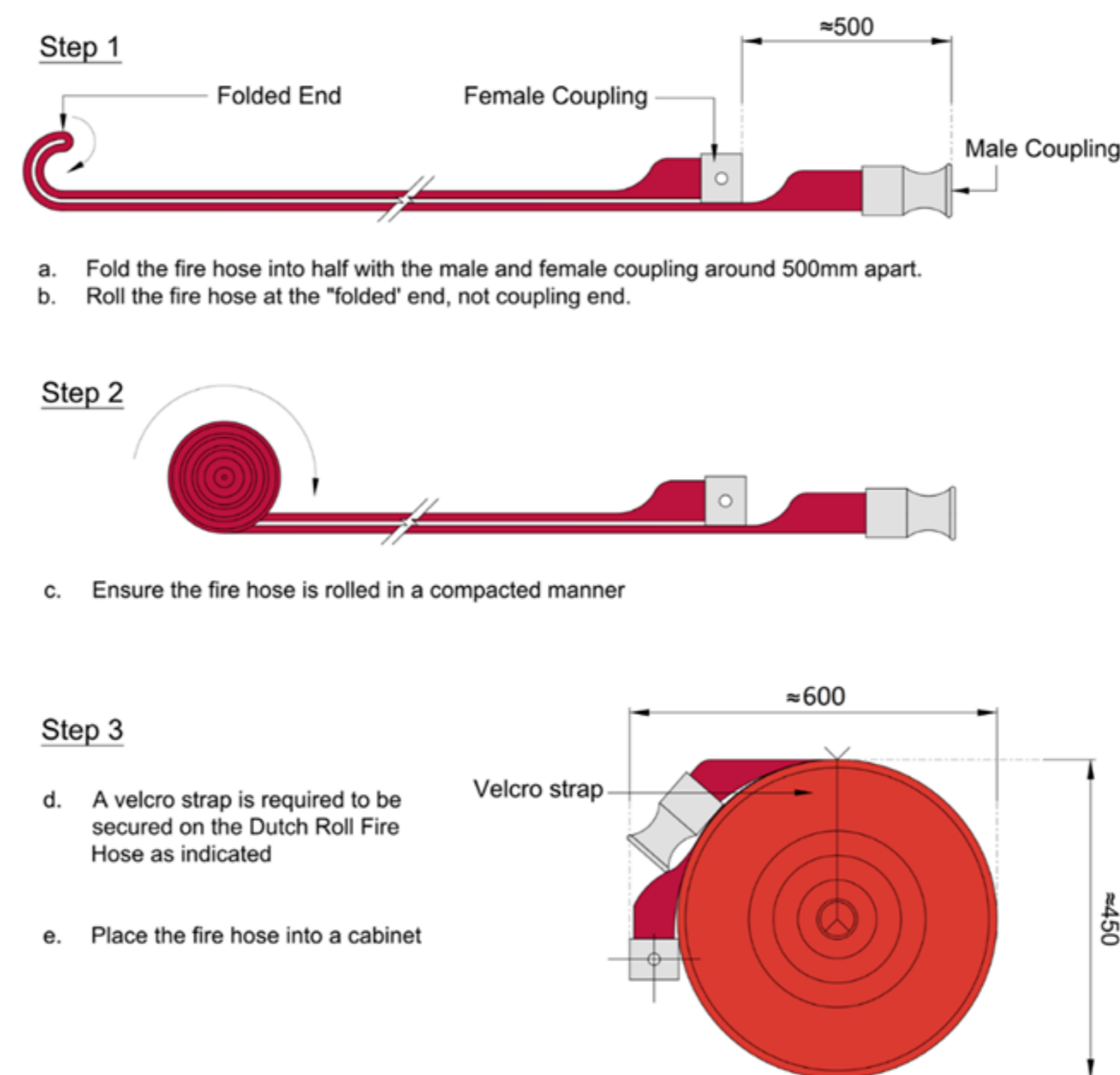

Diagram 6.2.4c.(9): Dutch Roll Folding Method

Diagram 6.6.9b.(1) – 1: Lift Landing Sill to Sill Distance > 11m but < 18m

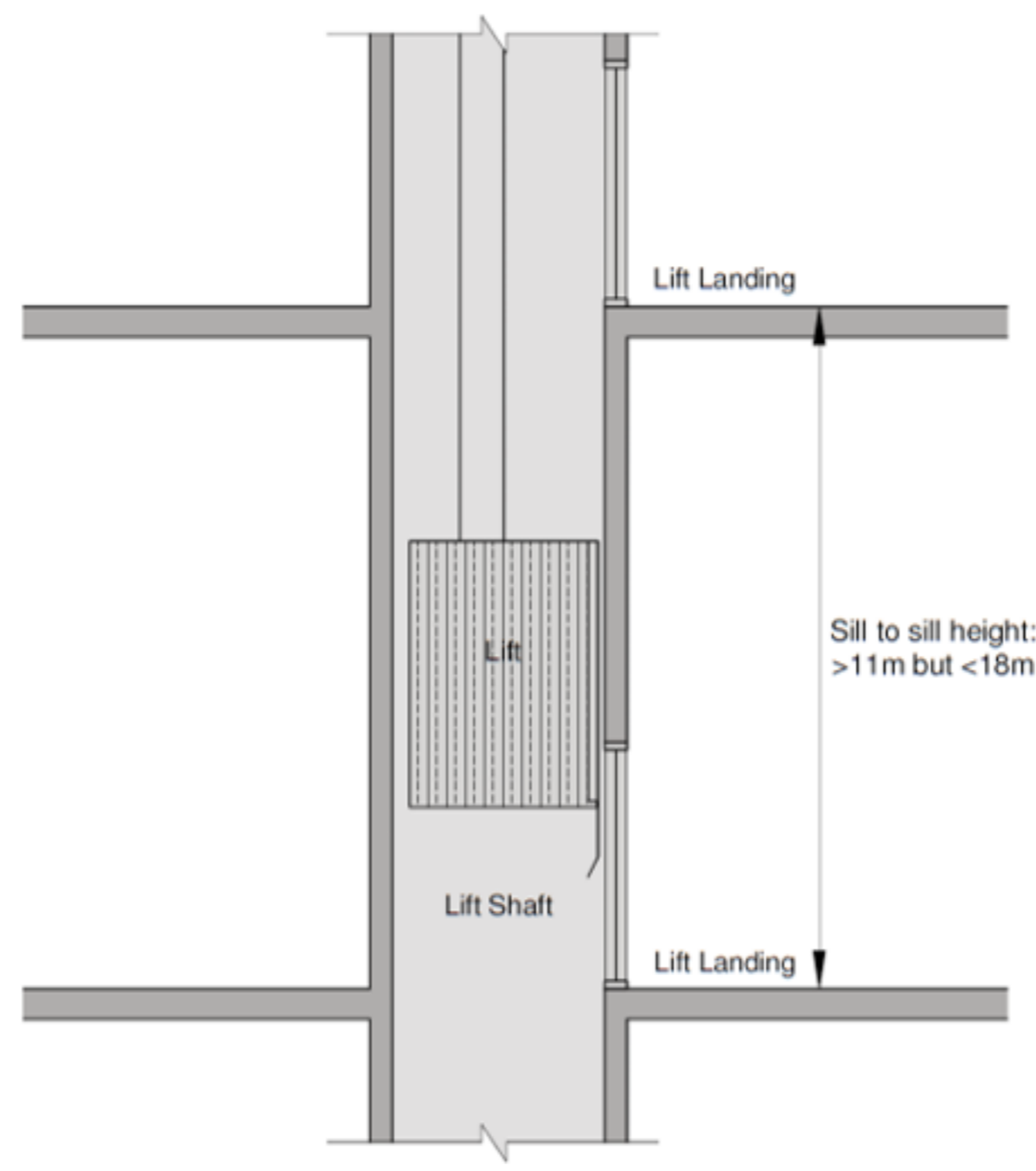

Diagram 6.6.9b(1) – 1: Lift Landing Sill to Sill Distance > 11m but < 18m

Diagram 6.6.9b.(1) – 2: Rescue Hooks Located at Lift Landing

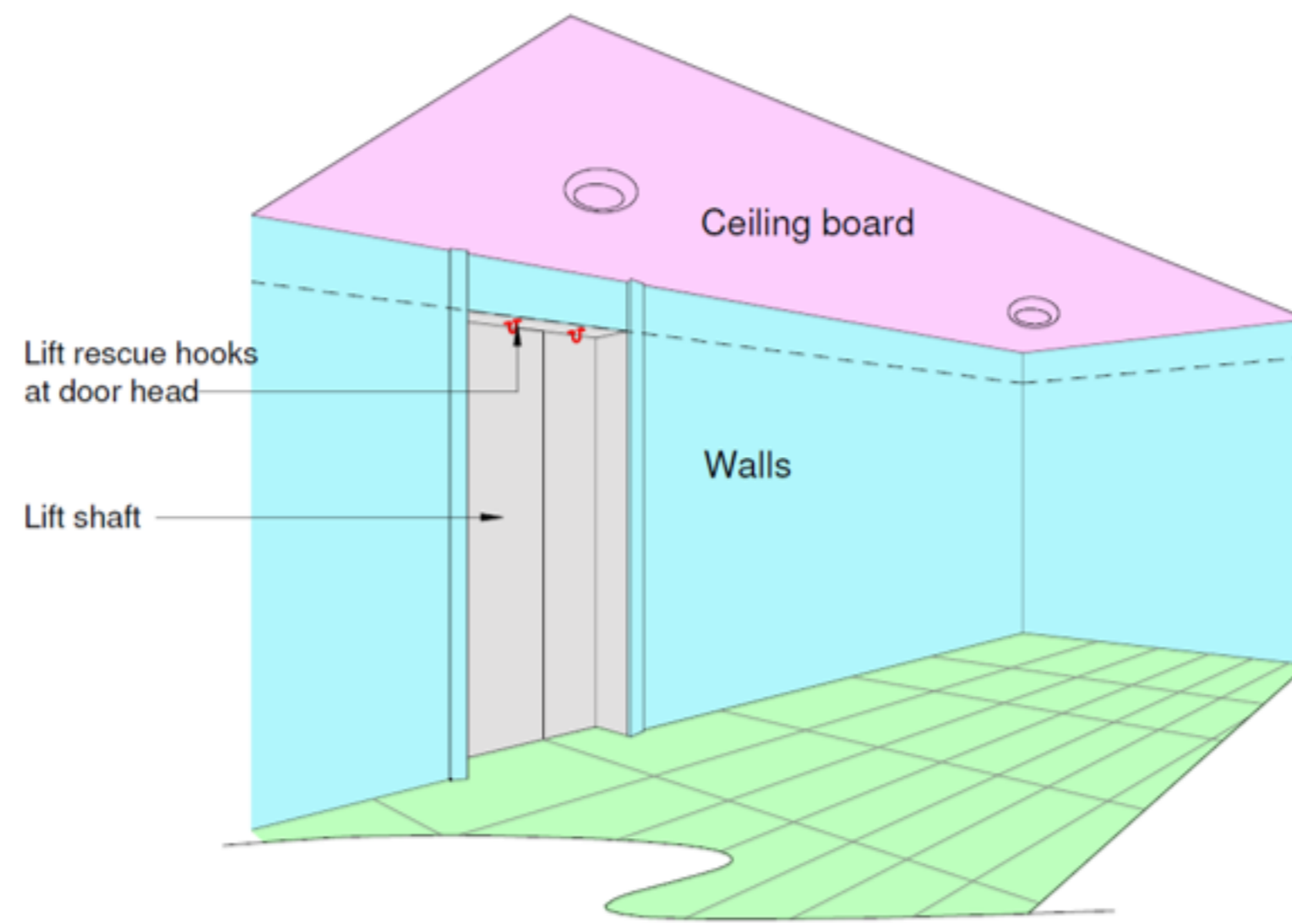

Diagram 6.6.9b(1) – 2: Rescue Hooks Located at Lift Landing

Diagram 6.6.9b.(2) – 1: Rescue Hooks Located Within Lift Landing Ceiling Space

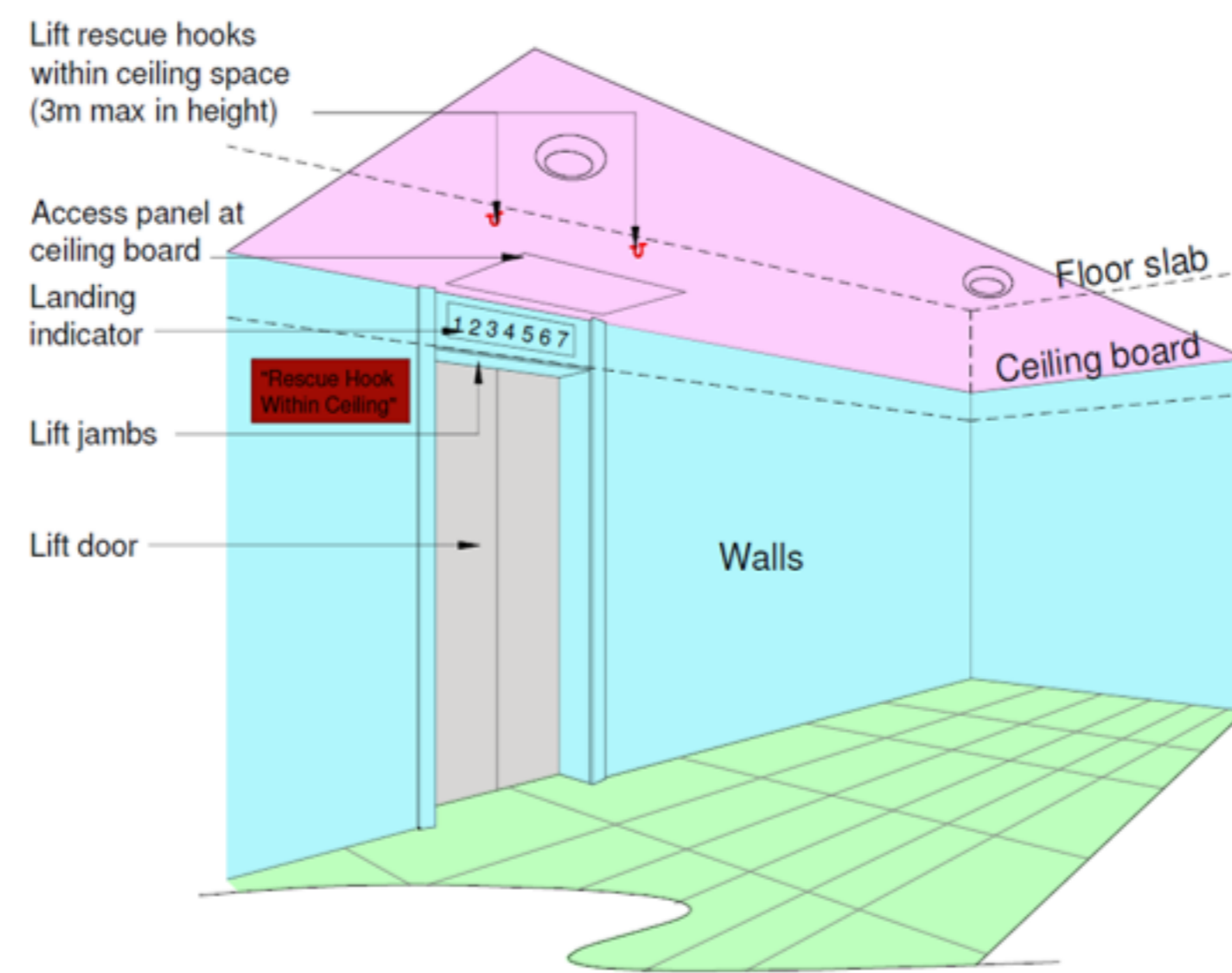

Diagram 6.6.9b(2) – 1: Rescue Hooks Located Within Lift Landing Ceiling Space

Diagram 6.6.9b.(2) – 2: Rescue Hooks Located Within Lift Landing Ceiling Space

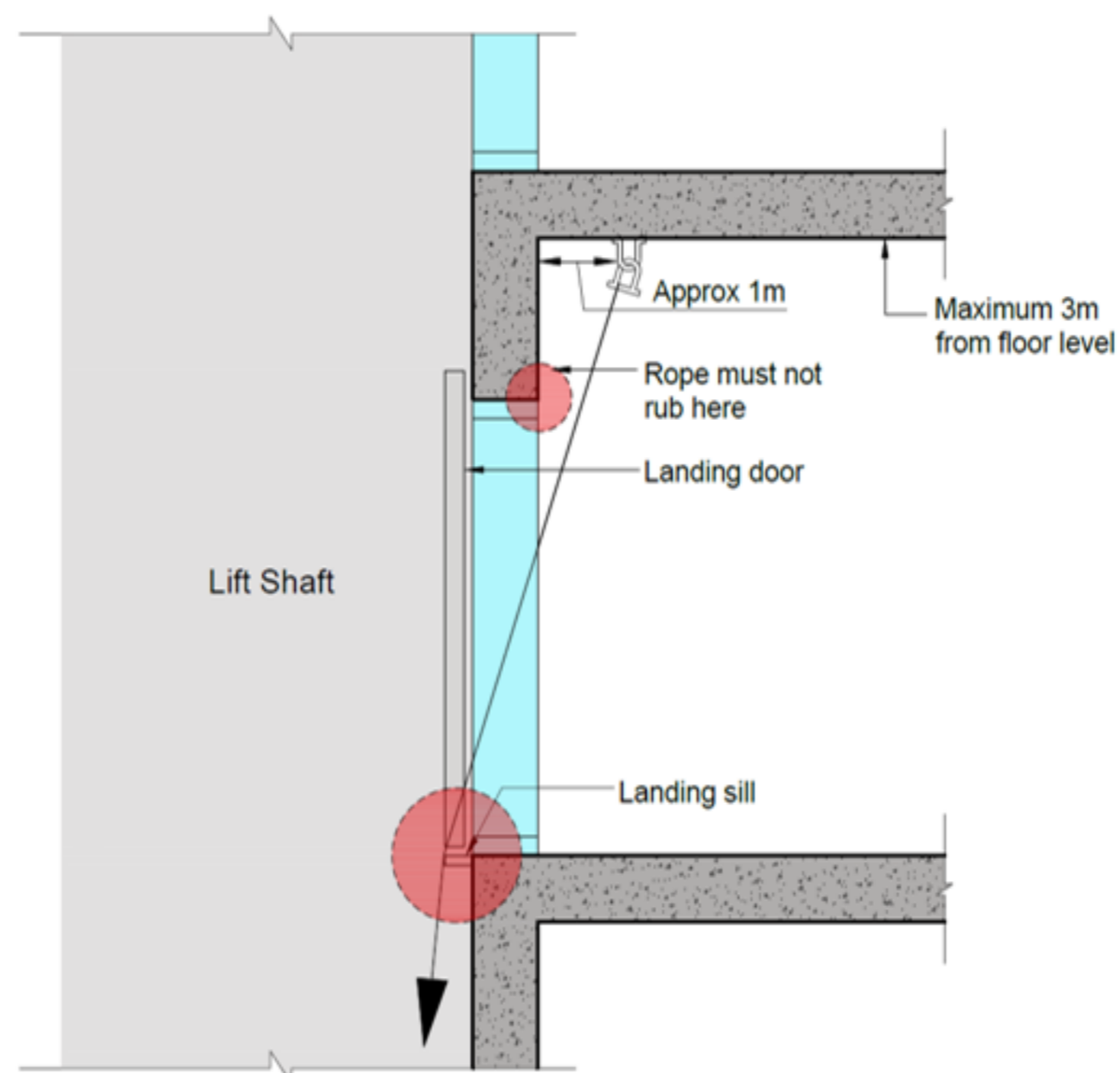

Diagram 6.6.9b(2) – 2: Rescue Hooks Located Within Lift Landing Ceiling Space

Diagram 6.6.9b.(3): Rescue Hook Design

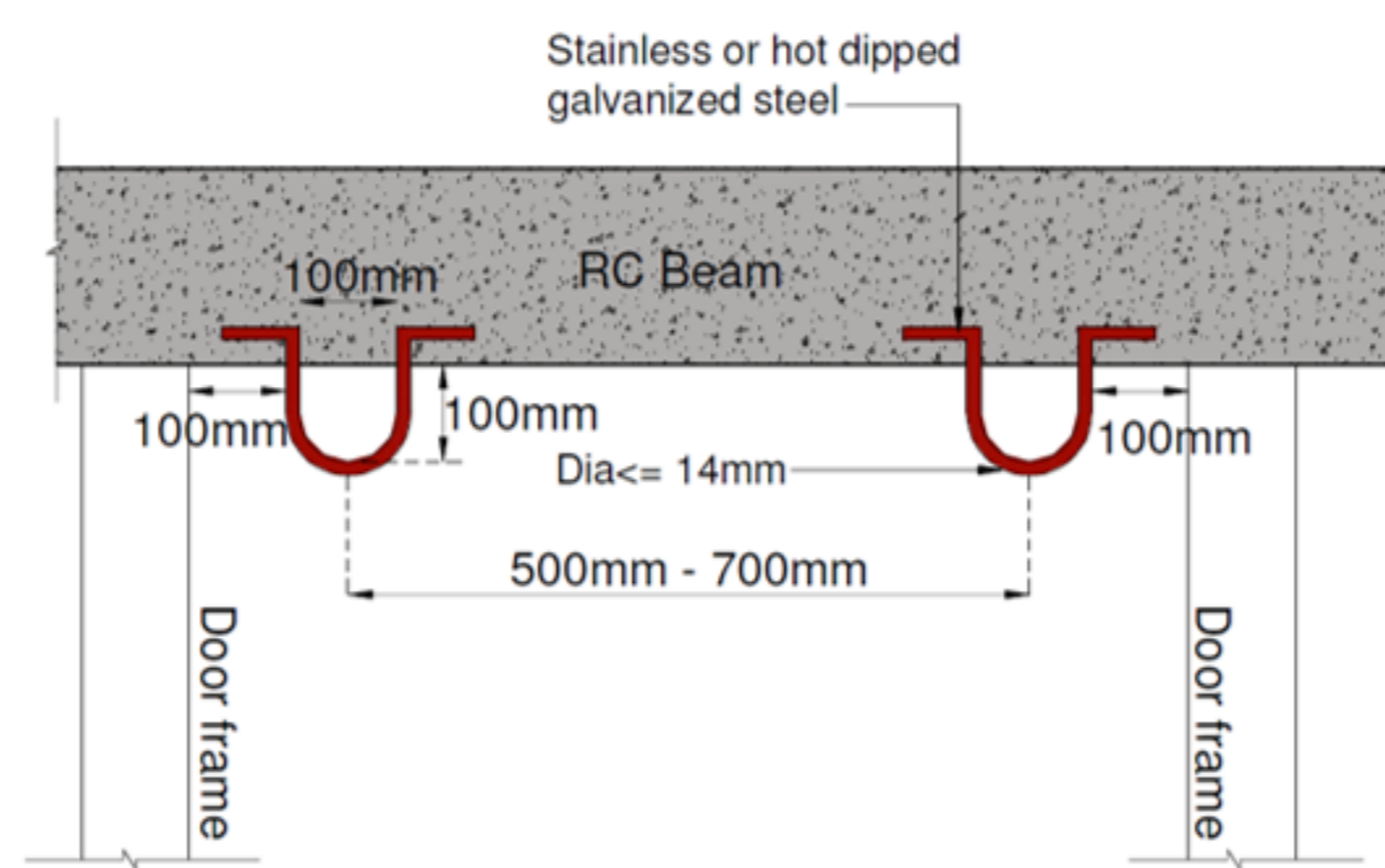

Diagram 6.6.9b(3): Rescue Hook Design

Diagram 6.6.9c.(2): Landing Emergency Door

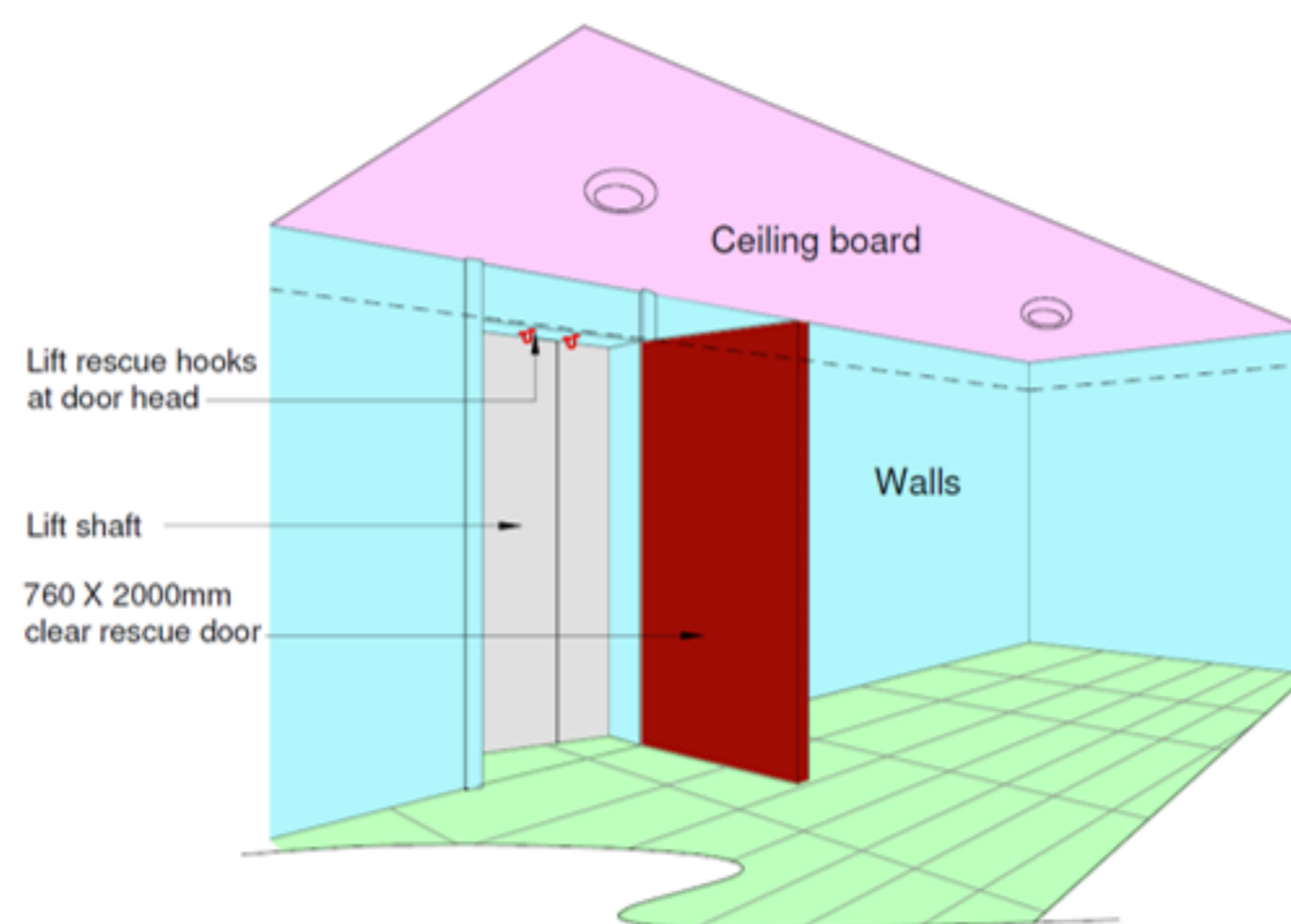

Diagram 6.6.9c(2): Landing Emergency Door

Diagram 6.6.9d.(1): Car Emergency Doors for Lift-to-lift Rescue

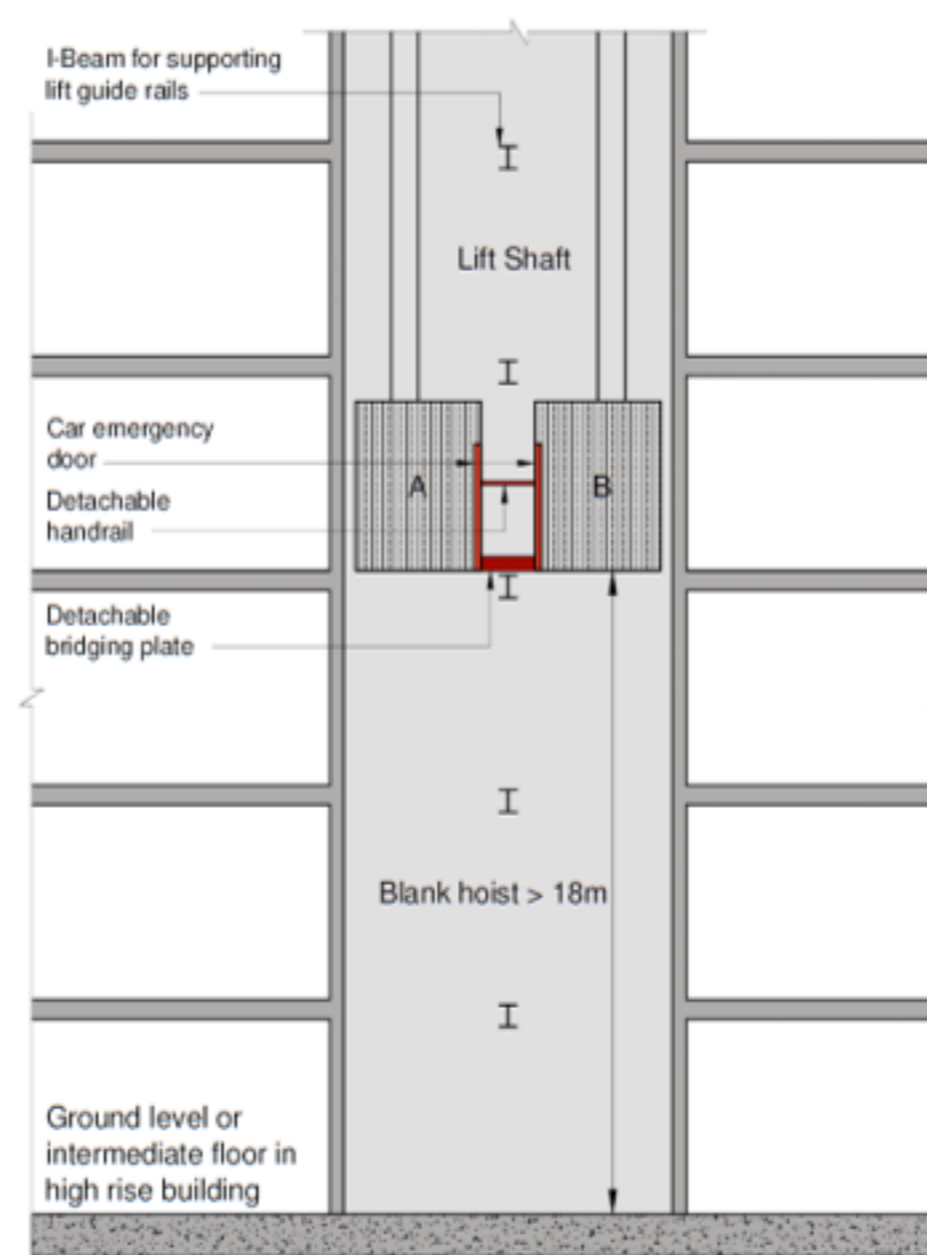

Diagram 6.6.9d(1): Car Emergency Doors for Lift-to-lift Rescue

Diagram 6.6.9d.(2): Car Emergency Doors – Deployed of Bridging Plate

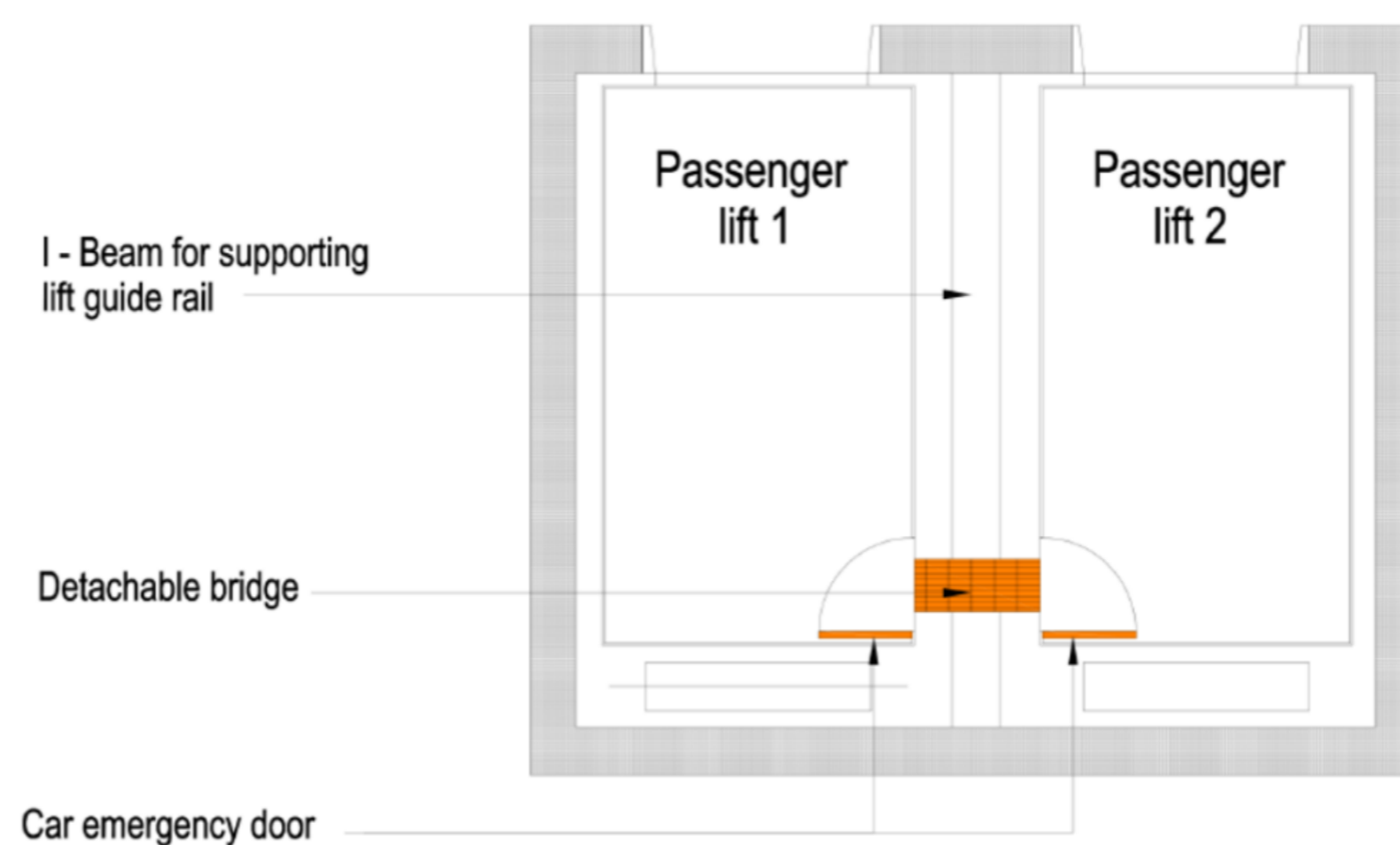

Diagram 6.6.9d(2): Car Emergency Doors – Deployed of Bridging Plate

Table 6.4A COMPARTMENTATION AND FIRE PROTECTION REQUIREMENTS

Table 6.4A COMPARTMENTATION AND FIRE PROTECTION REQUIREMENTS					
Usage (1)	Non-sprinkler-protected station (2)		Sprinkler-protected station (3)		
	Compartmentation (2a)	Door rating (2b)	Compartmentation (3a)	Door rating (3b)	Sprinkler (3c)
Store room	1-hr	1-hr	N	N	S
AHU room	N	N	N	N	S
Low voltage switch room	2-hrs	2-hrs	2-hrs	2-hrs	EX
High voltage switch room	2-hrs	2-hrs	2-hrs	2-hrs	EX
Transformer room (1)	2-hrs	2-hrs	1-hr	1-hr	S

Fuel/ Oil tank room	4-hrs	4-hrs	4-hrs	4-hrs	S
Generator room	4-hrs	4-hrs	4-hrs	4-hrs	S
Electric lift motor room (2)	2-hrs	2-hrs	2-hr	2-hrs	EX
Hydraulic lift motor room (2)	2-hrs	2-hrs	2-hr	2-hrs	S
Battery room (13)	2-hrs	2-hrs	2-hr	2-hrs	S(12)
Fire pump/ tank room	2-hrs	2-hrs	2-hr	2-hrs	S
Fire command centre	2-hrs	2-hrs	2-hr	2-hrs	S
MDF room, PABX room	N	N	2-hr	2-hrs	EX
			N	N	S
Public toilet (3)	N	N	N	N	S
Commercial space	2-hrs	2-hrs	1-hr	1-hr	S
Ticket vending machine room (3)	N	N	N	N	EX
Passenger Service Centre (PSC) (3)	N	N	N	N	EX
Station Manager Room (SMR) (3)	N	N	N	N	S (11)
Ticket sales office (3)	N	N	N	N	S
General purpose office (4)	N	N	N	N	S
Staff room (4)	N	N	N	N	S
Staff toilet/locker room (4)	N	N	N	N	S
Maintenance office (4)	N	N	N	N	S
Bin centre (5)	2-hrs	2-hrs	2-hrs	2-hrs	S
Tunnel ventilation fan room (6)	2-hrs	2-hrs	2-hrs	2-hrs	EX
ECS plant room	2-hrs	2-hrs	2-hrs	2-hrs	S
Electrical room	2-hrs	2-hrs	2-hrs	2-hrs	EX
Electrical closet	N	N	N	N	EX
Essential fan room (7)	2-hrs	2-hrs	2-hrs	2-hrs	S
Uninterruptible power supply room	2-hrs	2-hrs	2-hrs	2-hrs	EX
Pneumatic platform screen door room	2-hrs	2-hrs	2-hrs	2-hrs	S
Underplatform Services Duct (8)	2-hrs	2-hrs	2-hrs	2-hrs	EX
Civil defence room with storage	2-hrs	2-hrs	N	N	S
Civil defence room without storage	N	N	N	N	EX
Supply air shaft (9)	2-hrs	2-hrs	2-hrs	2-hrs	--
Exhaust air shaft (9)	2-hrs	2-hrs (10)	2-hrs	2-hrs (10)	--

Table 6.4A COMPARTMENTATION AND FIRE PROTECTION REQUIREMENTS – CONTINUED (2)

Table 6.4A COMPARTMENTATION AND FIRE PROTECTION REQUIREMENTS – CONTINUED (2)					
Usage (1)	Non-sprinkler-protected station (2)		Sprinkler-protected station (3)		
	Compartmentation (2a)	Door rating (2b)	Compartmentation (3a)	Door rating (3b)	Sprinkler (3c)
<p>Note: Essential equipment includes communication equipment, signalling equipment, uninterruptible power supply/emergency power supply charger/rectifier and HV/LV switchgears which are critical for the operation of trains, the emergency fire safety equipment, and the emergency evacuation of commuters. EX Sprinkler system is exempted from the corresponding area provided that the area is fitted with an automatic fire alarm system installed according with SS 645 N No specific requirement on compartmentation S Sprinkler system has to be extended into such rooms (1) 4-hr compartmentation if flammable liquids are used. Refer to Cl.3.2.4g.(1) (2) Openings for ropes and cables shall be kept as small as practicable (3) Wall/door separating the room and non-public area shall have at least 2-hr fire rating (4) Wall/door separating the room and public area shall have at least 2-hr fire rating (5) Compartmentation and sprinkler protection are not required if it is a stand-alone structure i.e. not adjoining or below transit structure(s) (6) Motorised dampers separating the room and the trainways need not have fire rating (7) Except as modified in Cl.6.4.2c. (8) The underplatform services duct (UPSD) shall also be divided longitudinally into two sections by a 2-hour fire-rated wall so that the two electrical feeders carrying electrical power supply for the RTS system are physically separated (9) No detectors are required in these air shafts (10) The door shall also be a smoke check door (11) Sprinkler is exempted where SMR meets the requirements of Cl.6.4.1d. (12) Water mist system can be considered in lieu of conventional automatic fire sprinkler system. (13) This requirements of compartmentation shall apply to any room that is designated as a battery room or Threshold Stored Energy exceeded the limits stated in Cl.10.3.1e. of the Code of Practice for Fire Precautions in Buildings. This does not apply to battery used in consumer products such as laptop, phone, etc.</p>					

Clause No.	Amendment Date	Effective Date	Clause Status	Clause Before Amendment	Circular Date
------------	----------------	----------------	---------------	-------------------------	---------------

CLAUSE 7.1 AIR-CONDITIONING AND MECHANICAL VENTILATION SYSTEMS

7.1.1 General

Where an air-conditioning system is provided in lieu of a mechanical ventilation system for emergencies, all the requirements specified in this Code for mechanical ventilation systems shall apply to the air-conditioning system.

7.1.2 Construction of ductwork

Ducts for air-conditioning and mechanical ventilation systems shall be constructed in compliance with all the following requirements:

a. Materials

Air-conditioning or other ventilation ducts, including framing thereof, shall be constructed of steel, aluminium, glass fibre batt, mineral wool batt, or other approved materials.

b. Support

Air-conditioning or other ventilation ducts shall be adequately supported.

c. Duct coverings, duct linings, and flexible connection

Duct covering, duct linings, and flexible connection shall be non-combustible. However, if it is necessary to use combustible material, it shall:

- (1) when tested in accordance with methods specified in this Code, have a surface flame spread rating of not lower than Class O;
- (2) when involved in fire, generate a minimum amount of smoke and toxic gases; and
- (3) be at least 1m away from a fire damper.

d. Flexible joints and connections

- (1) Flexible connections at the ends of ventilation ductwork connecting terminal units, extract units, and ventilation grilles shall not exceed 4m.
- (2) Flexible joints, which are normally provided to prevent and/ or allow for thermal movements in the duct system, shall not exceed 250mm in length.
- (3) Flexible joints shall be made of material classified as 'not easily ignitable' when tested under BS 476: Part 5.

e. Duct Enclosure

Enclosure of ducts shall comply with the requirements in [Cl.3.8.9a.](#)

f. Ductwork through smoke-free or fire lift lobbies

Ventilation ducts shall not pass-through smoke-free or fire lift lobbies. Where unavoidable, the part of the ventilation duct within the lobby shall be enclosed in masonry construction with fire resistance rating at least equal to that of the elements of structure. If other forms of fire resisting construction are used, a fire damper shall be fitted where the duct penetrates the lobby enclosure.

g. Ductwork through separating walls

No air-conditioning or ventilation duct shall penetrate separating walls.

h. Fire-rated duct

- (1) Where proprietary fire-rated materials are used to construct the fire-rated duct, the fire rating of the fire-rated duct shall have the same period of fire resistance as the wall or floor it penetrates.
- (2) Proprietary fire-rated duct shall be tested to BS 476: Part 24 or equivalent and its usage be approved by the SCDF.
- (3) Running of non-fire-rated duct and/ or other station services above the proprietary fire-rated duct shall be avoided. When unavoidable due to physical constraints, the supports to such non-fire-rated duct and/ or other station services running above the proprietary fire-rated duct shall be strengthened, such that the tensile stress generated on the supports shall not exceed 10N/mm². The non-fire-rated duct and/ or station services shall also be adequately protected to prevent collapse in a fire which will otherwise affect the stability of the proprietary fire rated duct below.
- (4) Fans forming part of a fire-rated duct shall also be enclosed in the same fire-rated enclosure.

i. Control panel

The location and placement of control panels serving engineered smoke control and smoke purging systems shall be located next to the main alarm panel or in rooms with at least 1 hr fire resistance. The control panels shall be clearly visible, readily accessible for operation and maintenance, and mounted at a height not more than 1.8m from the finished floor level.

Rationale

The control panel serving the fans of smoke control systems are crucial and must not be located within any smoke layer to ensure that the integrity of the smoke control system is not compromised in a fire emergency. The exhaust systems would not be operable in the event of failure of the control panels.

7.1.3 Insulation of pipework

Insulation for pipework associated with the air-conditioning and mechanical ventilation systems shall comply with the following requirements:

a. Flame spread rating

Insulation material for pipework, together with vapour barrier lining and adhesives shall when tested in accordance with the methods specified in this Code, have a surface flame spread of not lower than Class O.

b. Plastic and foam rubber insulation

Notwithstanding the requirements of [Cl.7.1.3a.](#), the use of plastic and foam rubber insulation materials of a lower classification is permitted only in aboveground stations if:

- (1) it is of the self-extinguishing type; and
- (2) the insulation is covered by or encased in a metal sheath, hybrid plaster, other non-combustible cladding material, or a fire-rated proprietary pipework system tested in the manner acceptable to the SCDF, provided that any opening in the element of structure or other part of a station penetrated by the pipework shall be effectively fire-stopped by replacement of the insulation material at the junction of penetration with fire resistant material having equal fire resistance rating.

7.1.4 Air plenum

Air plenums which do not contain combustible materials need not be provided with fire protection.

7.1.5 Fire Dampers

Any fire damper shall have a fire resisting rating of not less than that required for the compartment wall or compartment floor through which the relevant section of the ventilation duct passes. Fire dampers shall be of the type approved by the SCDF and constructed in accordance with the requirements in SS 333.

a. Provision of fire dampers

Ventilation ducts which pass directly through a compartment wall or compartment floor shall comply with the following:

- (1) where the ventilation duct does not form a protected shaft or is not contained within protecting structure, the duct shall be fitted with a fire damper where it passes through the compartment wall or compartment floor; and
- (2) where the ventilation duct forms a protected shaft or is contained within a protecting structure, the duct shall be fitted with fire dampers at the shaft inlets and outlets.

b. Installation of fire dampers

- (1) Fire dampers shall be installed so that the casing completely penetrates through the compartment wall or floor, and the casing shall be retained, either:
 - (a) on both sides by means of flanges in such a manner that it can expand under fire conditions without distorting the blades in the closed position, or
 - (b) on the accessible side by means of one flange only, which can be fixed to the damper and to the wall through slotted holes to allow for expansion.
- (2) Flanges shall be butted against the face of the compartment wall or floor and fixed to the damper casing.
- (3) Ductwork connected to the damper shall be attached in such a manner as to ensure that the damper remains securely in position and is fully functional in the event of damage of ductwork.
- (4) The clearance between the damper body and the sides of the penetration shall not be less than that of the tested prototype and be not greater than half the width of the angled section of the collar.

- (5) The space between the damper body and the opening in the wall or floor shall be fire-stopped.
- (6) Vertically positioned fire dampers shall be installed in such a manner that the direction of air flow assists in the closure of the damper.
- (7) Connections to fire dampers

The distance between the plane through a closed fire damper and ducting, flexible connections, duct coverings, internal linings, and the like, shall be:

- (a) no less than 1m when such parts are made of materials with fusing temperatures less than 1000°C;
- (b) no less than three times the diagonal or diameter of the damper; and
- (c) no less than 2m when such parts are made of materials that are combustible, except for vapour barrier to provide thermal insulation.

(8) Fire damper inspection access doors

Each fire damper installation shall be provided with an inspection access door in the ventilation duct, either upstream or downstream, as appropriate. The access door dimension shall measure 450mm (L) x 450mm (W); for smaller ducts, the door width dimension can be reduced to the width or depth of the duct. Access doors shall be hinged and fitted with sash locks and be constructed of minimum 1.25mm suitably braced sheet steel. Openings in ducts shall be stiffened by a sheet steel frame.

c. Prohibition of fire dampers

Fire dampers shall not be fitted in any of the following locations:

- (1) openings for ducts of emergency ventilation systems in walls of ventilation shaft, or
- (2) openings in walls of a protected shaft when the openings have a kitchen exhaust duct passing through it, or
- (3) opening in walls of a protected shaft when the openings have a fume hood exhaust duct passing through it, or
- (4) anywhere in an air pressurising system, or
- (5) in locations explicitly prohibited in this Code.

7.1.6 Locations of intakes and return air openings

a. Openings for the intakes of outdoor air to all air handling systems, mechanical ventilation systems, pressurisation systems of exit staircases and internal corridors, and smoke control systems shall be no less than 5m from any exhaust discharge openings.

b. All return air openings and outdoor air intakes shall be located and arranged such that sources of ignition, such as lighted matches and cigarette butts, which accidentally enter the openings and intakes cannot be deposited onto the filter media.

c. Re-circulation of smoke

The intake and exhaust air shafts shall be positioned or protected to prevent re-circulation of smoke into the system through air intake openings, station entrances, and other surface of openings. Adjacent structures and property shall also be considered.

7.1.7 Air handling unit (AHU) room

Rooms having no other usage than housing air handling equipment or package units and their associated electrical controls are not regarded as areas of high risk.

a. Compartmentation

- (1) Where the air handling equipment serves more than one compartment, fire dampers shall be provided in air ducts at penetrations through the compartment walls and floors to comply with the requirements in [Cl.7.1.5](#).
- (2) Where AHU rooms are vertically stacked, each AHU room shall be separated by a compartment floor at every level.

Rationale

Rooms having no usage other than housing air handling equipment or package units, and their associated electrical controls are typically not regarded as areas of high risk and therefore compartmentation is not required. However, fire dampers shall be provided within the air ducts of the air handling equipment where they penetrate through compartments to prevent fire spread.

b. Smoke Detectors

(1) Smoke detectors of approved type shall be incorporated in the return air stream immediately adjacent to:

- (a) AHUs serving more than one storey or compartment, or
- (b) a single AHU in excess of 15000m³/h.

(2) The function of smoke detectors, where required by this Code, is to initiate action to shut down the AHU automatically when the smoke density in the return air system has become unacceptable for recycling.

c. Stop switch

Where the AHUs in a station are not centrally controlled, each AHU exceeding 8500m³/h shall be provided with a manual stop switch to facilitate quick shutting down of the fan in the case of fire. For ease of access, this switch shall be located on the wall next to the door opening of the air handling equipment room.

7.1.8 Ventilation system for exit staircase and internal exit passageway

A mechanical ventilation system for each exit staircase and internal exit passageway, if provided, shall be an independent system of supply mode exclusive to the particular staircase, or internal exit passageway, and it shall comply with all of the following requirements:

- a. Supply air for the system shall be drawn directly from the external space/ air shaft, with intake point not less than 5m from any exhaust discharge openings.
- b. For exit staircase serving more than four storeys, supply air shall be conveyed via a vertical duct extending throughout the staircase height and discharging through outlets distributed at alternate floors.
- c. Where the supply air duct serving the exit staircase must penetrate the staircase enclosure, the portion of the duct where it traverse outside the staircase shall be enclosed in masonry construction or drywall complying with [Cl.3.8.7c](#). of at least the same fire resistance as the elements of structure, and it shall not be fitted with fire dampers.
- d. The ventilation system shall be of supply mode only, and of not less than 4 air changes per hour.
- e. The mechanical ventilation system shall be automatically activated by the station fire alarm system. In addition, a remote manual start-stop switch shall be made available to firefighters at the FCC, or, where there is no FCC, next to the main fire alarm panel.
- f. Visual indication of the operational status of the mechanical ventilation system shall be provided.
- g. The mechanical ventilation for the exit staircase shall be maintained at higher pressure with respect to the mechanical ventilation system of the adjacent fire lift lobby.
- h. Where duct risers are required to be enclosed in protected shafts, the protected shafts shall be enclosed in masonry construction or drywall complying with [Cl.3.8.7c](#).

7.1.9 Ventilation system for smoke-free lobby and fire lift lobby

- a. The ventilation system shall be of supply mode only of not less than 10 air changes per hour.
- b. Supply air shall be drawn directly from the external space/ air shaft with intake point not less than 5m from any exhaust discharge or openings for natural ventilation.
- c. Any part of the supply duct running outside the smoke-free or fire lift lobby which it serves shall either be enclosed or constructed to give a 1-hr fire resistance rating. The SCDF may, at its discretion, require a higher fire resistance rating if the duct passes through an area of high fire risk.
- d. The mechanical ventilation system shall be automatically activated by the station fire alarm system. In addition, a remote manual start-stop switch shall be made available to firefighters at the FCC or where there is no FCC, next to the main fire alarm panel.
- e. Visual indication of the operational status of the mechanical ventilation system shall be provided.

7.1.10 Ventilation system for fire pump room and generator room

Where mechanical ventilation is installed to provide a smoke-free environment for the room housing the fire pump or emergency generator, such systems shall be independent of each other and of any other system serving other parts of the station/ building, and shall comply with all of the following requirements:

- a. Supply air shall be drawn directly from the external space/ air shaft and its intake point shall not be less than 5m from any exhaust discharge openings. Exhaust discharge shall also be direct to the external space/ air shaft.
- b. Where the corresponding ducts run outside the room, they shall either be enclosed in a structure or be constructed to give at least the same fire rating as the room which they serve, or that of the room through which they traverse, whichever is higher. The rating shall apply to fire exposure from both interior and exterior of the duct or structure. Where the duct risers are required to be enclosed in a protected shaft constructed of masonry or drywall complying with [Cl.3.8.7c](#), they shall be compartmented from the rest of the shaft space containing other ducts or service

installations.

c. No fire damper shall be fitted in either supply or exhaust duct required under this clause.

d. A duct serving areas other than rooms housing equipment stated in this clause shall not pass through such rooms.

7.1.11 Ventilation system for Fire Command Centre (FCC)

The FCC can either be air-conditioned, naturally ventilated, or mechanically ventilated. The air-conditioning or mechanical ventilation shall be independent of each other and any other system serving other parts of the station. Where mechanical ventilation is required, it shall also comply with all the following requirements:

a. Supply air shall be drawn directly from the external space/ air shaft and its intake point shall not be less than 5m from any exhaust discharge openings. Exhaust discharge shall also be direct to the external space/ air shaft.

b. Where the corresponding ducts run outside the FCC, they shall either be enclosed in a structure or be constructed to give at least the same fire rating as the room which they serve or that of the room through which they traverse, whichever is higher. Where the duct risers are required to be enclosed in a protected shaft constructed of masonry or drywall complying with [Cl.3.8.7c](#), they shall be compartmented from the rest of the shaft space containing other ducts or service installations.

c. No fire damper shall be fitted in either supply or exhaust duct required under this Clause.

d. A duct serving areas other than the FCC shall not pass through the room.

7.1.12 Exhaust system for kitchen

a. Provision

A mechanical exhaust system for the cooking area of a kitchen in an eating establishment or the like shall be independent of those serving other parts of the station. It shall also comply with all the following requirements:

(1) The hood and ducts for the exhaust shall have a clearance of 500mm from unprotected combustible materials.

(2) The exhaust shall discharge directly to the external space/ air shaft and shall not be less than 5m from any air intake openings.

(3) The exhaust duct, where it runs outside the kitchen, shall either be enclosed in a structure or be constructed to give at least the same fire rating as the kitchen or that of the room through which it traverses, whichever is higher. The rating shall apply to fire exposure from both interior and exterior of the duct or structure. Where the duct riser is required to be enclosed in a protected shaft constructed of masonry or drywall complying with [Cl.3.8.7c](#), it shall be compartmented from the rest of the shaft space containing other ducts or services installations.

(4) No fire damper shall be fitted in kitchen exhaust ducts.

b. Sharing of kitchen exhaust system

Sharing of kitchen exhaust system for food and beverage outlets is allowed, provided all the following conditions are complied with:

(1) For food courts

(a) The food court shall be under a single ownership/ operator.

(b) All kitchen exhaust ducts running outside the food court shall have 1-hr fire resistance rating or shall not be less than that for the elements of structure, whichever is higher.

(2) For restaurants/ small F&B outlets (e.g. snack bars, food kiosks, etc.)

(a) Restaurants and small F&B outlets that are sharing the same kitchen exhaust system shall be located on the same storey and within the aggregate zone area not exceeding 2000m². The maximum length of the aggregate zone covering from the first to the last restaurant/ F&B outlet shall not exceed 50m.

(b) The aggregate floor area of the restaurants and F&B outlets shall not exceed 1000m².

(c) Common ducts shall be provided with a common exhaust fan.

(d) The station shall be protected by an automatic fire sprinkler system.

(e) The exhaust hood shall be fitted with a wet chemical fire extinguishing system.

(f) The fire rating of the common kitchen exhaust duct running outside the restaurants shall have 1-hr fire resistance rating or shall not be less than that for the elements of structure, whichever is higher.

(Note: Kitchen exhaust ducts include both horizontal and vertical ducts.)

c. Kitchen exhaust duct

(1) A kitchen exhaust duct running outside a station shall not be located within 3m of any unprotected openings. This separation distance can be reduced to 1.5m if the unprotected opening is on the same plane as the duct. See [Diagram 7.1.12c\(1\) - 1 and 2](#).

(2) Where the distances mentioned above cannot be achieved, a fire resistant construction having at least ½ hr fire resistance shall be placed between the duct and the unprotected opening. See [Diagram 7.1.12c\(2\)](#).

(3) A non-fire-rated kitchen exhaust duct shall not be located above an LPG storage cabinet unless they are separated from LPG cylinders by a minimum of 2-hr fire-rated masonry construction above and beside the cylinders. See [Diagram 7.1.12c\(3\)](#).

(4) The kitchen exhaust duct shall be located at least 3m from any unprotected LPG cylinders. Non-fire-rated kitchen exhaust duct shall be located at least 600mm from the vapouriser or any liquid-phase LPG pipeline. See [Diagram 7.1.12c\(4\)](#).

d. Maintenance

All kitchen exhaust systems shall be properly maintained. The entire (interior and exterior) exhaust duct and kitchen hood shall be degreased and cleaned at least once every 12 months. The work shall be carried out by a specialist and the records of cleaning and degreasing shall be kept by the owner/ operator for verification. This requirement shall be included in the Fire Safety Instruction Manual.

Note

The respective building owner, MCST and eating outlet operators shall ensure that the entire (interior and exterior) kitchen exhaust duct and kitchen hood shall be degreased and cleaned at least once every 12 months. The work shall be carried out by a specialist and the records of cleaning and degreasing shall be kept by the owner/operator for verification.

7.1.13 Ventilation system for rooms housing batteries

Explanation and Illustrations

These requirements shall apply to any room that is designated as a battery room or Threshold Stored Energy exceeded the limits stated in Cl.10.3.1e. of the Code of Practice for Fire Precautions in Buildings. This does not apply to battery used in consumer products such as laptop, phone, etc.

Rooms housing batteries shall comply with the following requirements:

a. The batteries shall be of either vented or sealed type.

b. The room ventilation system shall be designed to limit the maximum concentration of Hydrogen (H₂) gas to 1% of the total volume of the room during the worst-case event of simultaneous "boost" charging of the batteries. The inlets and outlets of the ventilation system shall be properly located so that there is no stagnant area in the room.

c. Adequate hydrogen gas detectors shall be provided inside the room to monitor the hydrogen concentration and to activate the fan, if necessary, to ensure that the hydrogen concentration level at any part of the room does not exceed 1% of the total volume of the room. Display panels showing the readings of the detectors shall be located at the entrance to the room. At the same time, an alarm signal shall be sent to a manned station such as PSC, guard house or FCC.

d. The design of the battery room ventilation shall be in accordance with BS EN IEC 62485-2 & BS EN IEC 62485-3.

e. For mechanically ventilated battery rooms, the ventilation requirement shall be based on [Cl.7.1.13d](#), or 6 air changes per hour, whichever is higher.

f. No fire damper shall be provided in the essential ventilation system and ducts passing through other compartments shall have 2-hr fire resistance rating.

g. Essential fans and associated electrical controls shall be backed up with a secondary source of power supply.

Explanation and Illustrations

Secondary source of power supply shall be provided to ensure the mechanical ventilation system would not be affected during power failure. Redundancy fan is not required.

7.1.14 Smoke control fan rooms

Ductwork not serving smoke control fan rooms shall not pass through the smoke control fan room.

7.1.15 PVC pipes

PVC pipes are prohibited in underground stations, except PVC pipe sleeves and condensate drain pipes for air-conditioning units as stipulated in [CI.3.15.13](#).

7.1.16 Air shafts

a. Fresh/ exhaust air of the station's smoke control and mechanical ventilation systems can be taken from/ discharge to the intake/ exhaust air shafts as shaded in [Diagram 7.1.16 – 1 & 2](#) below respectively of the underground station. The connection to the air shafts shall be designed to prevent recirculation of air to the other ventilation system.

b. Air shafts shall be constructed of masonry and shall only contain equipment and services serving the air shafts and services stated in [Table 7.1.16](#)

Explanation and Illustrations

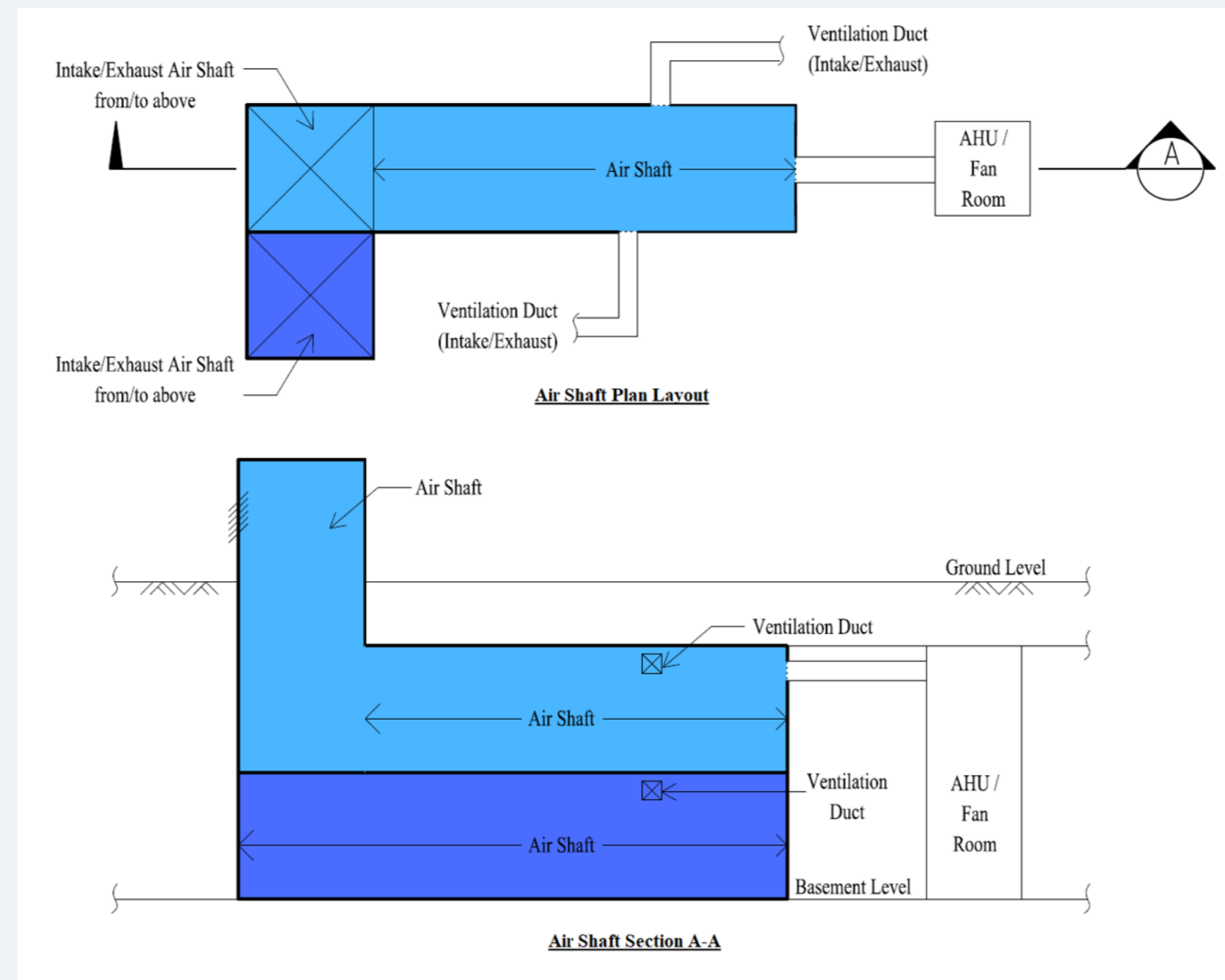

Cross-sectional area of the horizontal air shaft shall not be smaller than that of the vertical portion. Each air shaft shall maintain its compartmentation.

7.1.17 Power supply

Primary and secondary power supply shall comply with [CI.5.2](#).

7.1.18 Replacement air

Where replacement air is taken from doorways at station entrances, devices or other measures shall be incorporated to admit replacement air upon activation of the emergency ventilation system. This is to achieve the design requirements during operating hours and non-operating hours when the station is closed for passenger service.

CLAUSE 7.2 PRESSURISATION FOR EXIT STAIRCASES

7.2.1 Provision

a. Internal exit staircase

In any station of which the habitable height exceeds 24m, any internal exit staircases without adequate provision for natural ventilation shall be pressurised to comply with the requirements in this Code. Where the upper part of the staircase is naturally ventilated, its lower part can be provided with mechanical ventilation or pressurisation, whichever is appropriate.

b. Basement

In a station comprising more than four basement storeys, exit staircases connected to a fire lift lobby in basement storeys shall be pressurised to comply with the requirements in this Code.

7.2.2 Pressurisation level

a. When in operation, the pressurisation system shall maintain a pressure differential of not less than 50Pa between the pressurised exit staircase and the occupied area when all doors are closed.

b. Where a smoke-free lobby is also pressurised, the pressure at the exit staircase shall always be higher.

c. The force required to open any door against the combined resistance of the pressurising air and the automatic door closing mechanism shall not exceed 110N at the door handle.

7.2.3 Egress velocity

a. When in operation, the pressurisation system shall maintain an airflow of sufficient velocity through open doors to prevent smoke from entering the pressurised area.

b. The flow velocity shall be attained when a combination of two doors from any two successive storeys and the main discharge door are fully open.

c. The velocity averaged over the full area of each door opening shall not be less than 1.0m/s.

7.2.4 Leakages

a. The rate of supply of pressurised air to the pressurised areas shall be sufficient to make up for loss through leakages into the unpressurised surroundings.

b. Adequate relief of leaked air out of the occupied area shall be provided to avoid a pressure build-up in this area. The relief can be in the form of perimeter leakages or purpose-built extraction systems.

7.2.5 Distribution of pressurising air

a. The number and distribution of injection points for supply of pressurising air to the exit staircase shall ensure an even pressure profile complying with [Cl.7.2.2](#).

b. The arrangement of the injection points and the control of the pressurisation system shall be such that when the opening of doors or other factors cause significant variations in pressure difference, the condition in [Cl.7.2.2](#) shall be restored as soon as practicable.

7.2.6 Pressurisation equipment and controls

a. All the equipment and the relevant controls associated with the pressurisation system shall be designed and installed to ensure satisfactory operation in the event of a fire.

b. Supply air for the pressurisation system shall be drawn directly from the external space/ air shaft and its intake shall not be less than 5m from any exhaust discharge openings.

c. The pressurisation system shall be automatically activated by the station fire alarm system. In addition, a remote manual start-stop switch shall be made available to firefighters at the FCC, or next to the fire alarm panel where there is no FCC. Visual indication of the operation status of the pressurisation system shall be provided.

CLAUSE 7.3 SMOKE CONTROL SYSTEM

(5) Predetermined procedures for initiating quick response from the OCC during fire.

Fans not designed to function during fire shall shut down automatically upon activation of the emergency ventilation system unless it can be proven that the emergency air flow is not jeopardised or conflicted with.

d. Fan temperature rating

Emergency ventilation fans, their motors and all related components exposed to the exhaust airflow shall be capable of operating in an atmosphere of 250°C for at least 2 hrs.

Emergency ventilation fan motors shall be designed to achieve their full operating speed in 30 secs or less from a stopped position when started across the line and in 60 secs or less for variable speed motors

f. Fan motor starters and protective devices

Local fan motor starters and related operating control devices shall be located as far away from the direct air stream of the fans. Thermal overload protective devices shall not be used on motor control of fans used for emergency ventilation

h. Fail-safe replacement air

Smoke barrier shall be provided above platform screen doors. The materials used for the construction of the smoke barrier shall have a fire resistance rating of at least 2 hrs.

i. Smoke barrier

Explanation and Illustrations

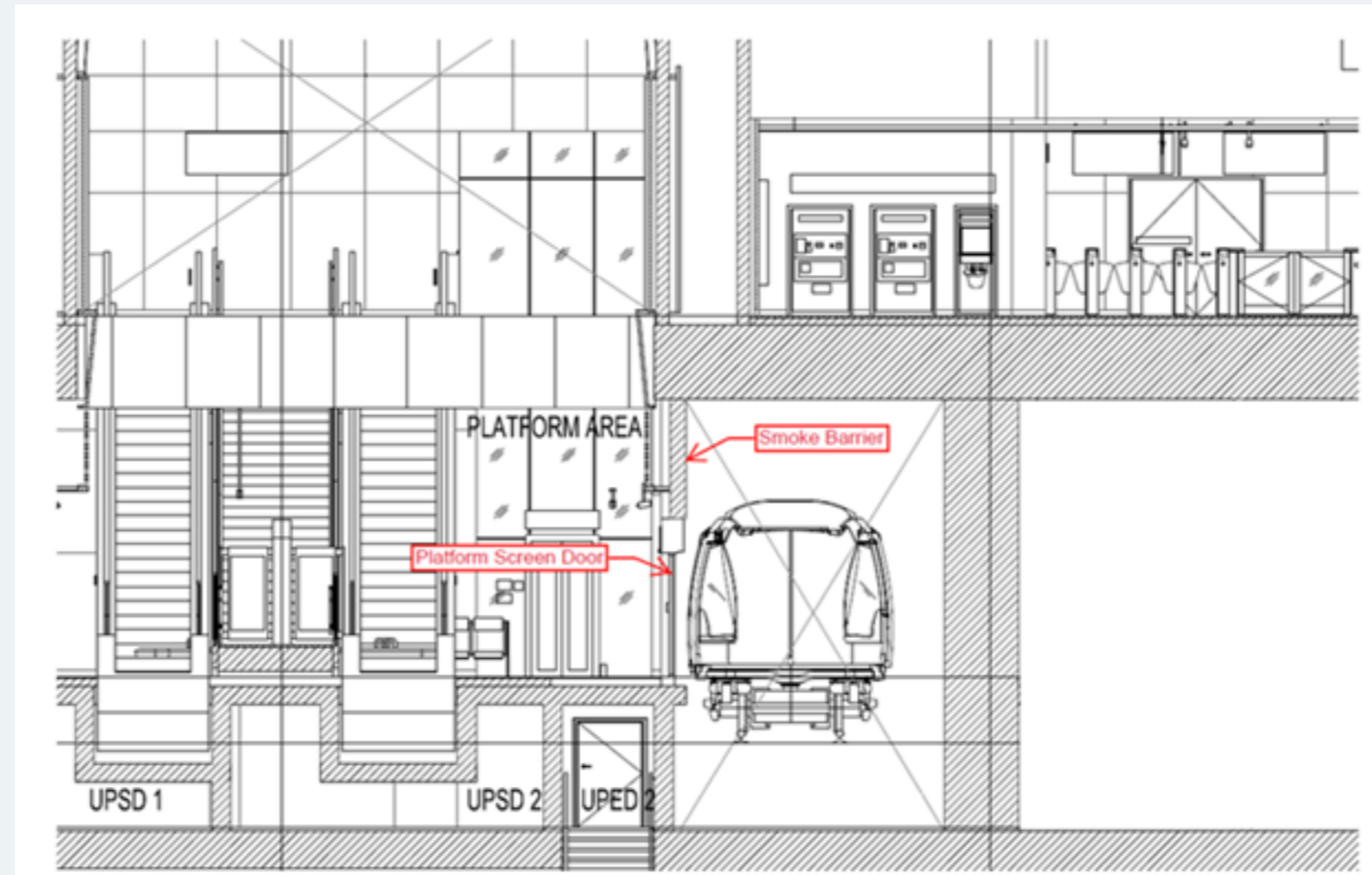

CLAUSE 7.4 REDUNDANCY FOR MECHANICAL VENTILATION AND PRESSURISATION SYSTEMS

7.4.1 Powered system

A standby fan (N+1) shall be provided for each of the following systems, such that in the event one of the duty fans fails or taken out of service, the standby fan shall be automatically activated to meet the required ventilation rate:

- a. mechanical ventilation systems for:
 - (1) smoke-free/ fire lift lobbies;
 - (2) exit staircases; and
 - (3) essential rooms (e.g. sprinkler, hydrant, hose reel pump room, standby generator room, FCC, etc.).
- b. engineered smoke control system;
- c. smoke purging system; and
- d. pressurisation systems for smoke-free/ fire lift lobbies and exit staircase.

Diagram 7.1.12c.(1) - 1: Unprotected opening perpendicular to the kitchen exhaust duct

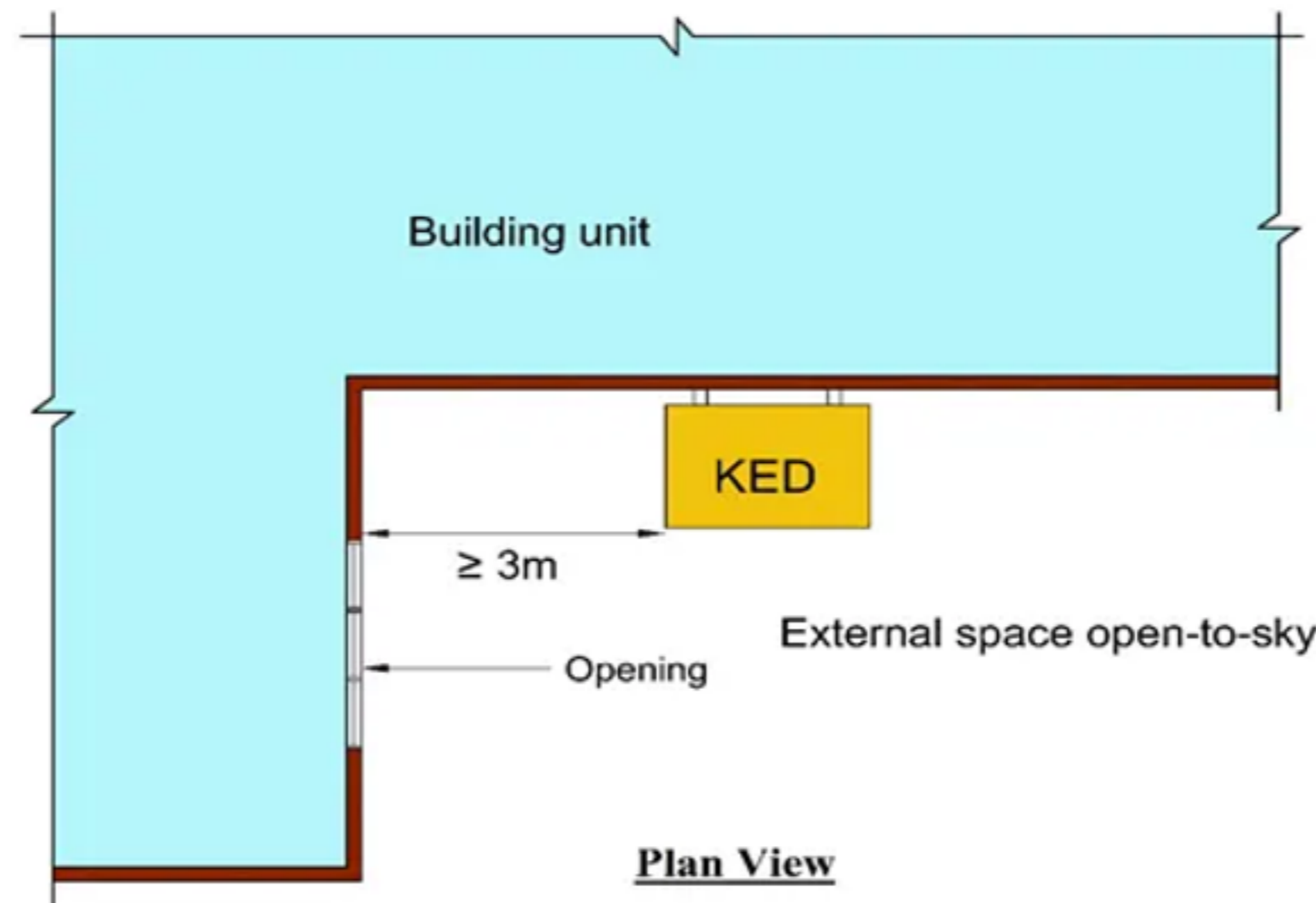

Diagram 7.1.12c(1) - 1: Unprotected opening perpendicular to the kitchen exhaust duct

Diagram 7.1.12c.(1) - 2: Unprotected opening parallel to the kitchen exhaust duct

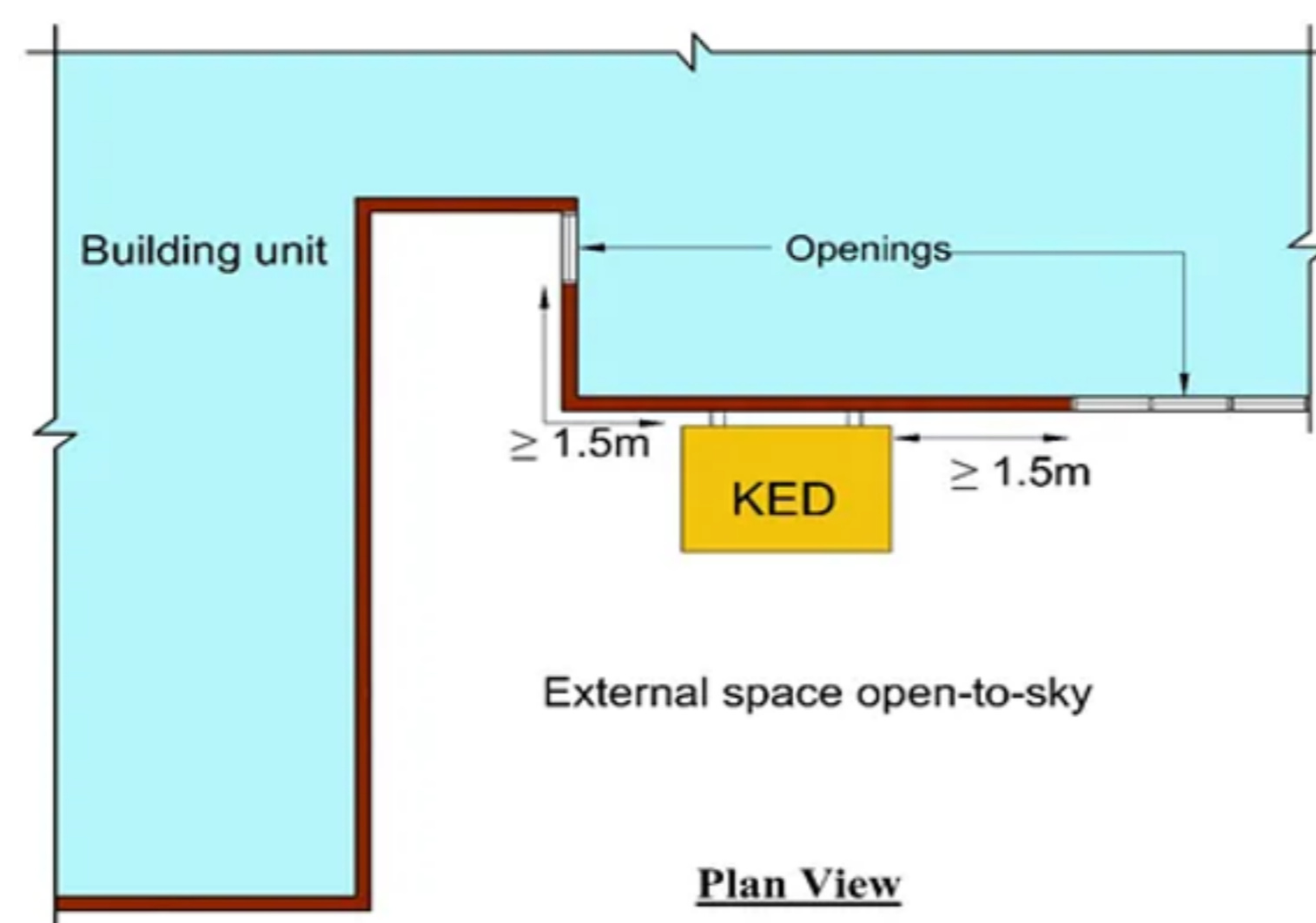

Diagram 7.1.12c(1) - 2: Unprotected opening parallel to the kitchen exhaust duct

Diagram 7.1.12c.(2): Fire resistance construction for kitchen exhaust duct

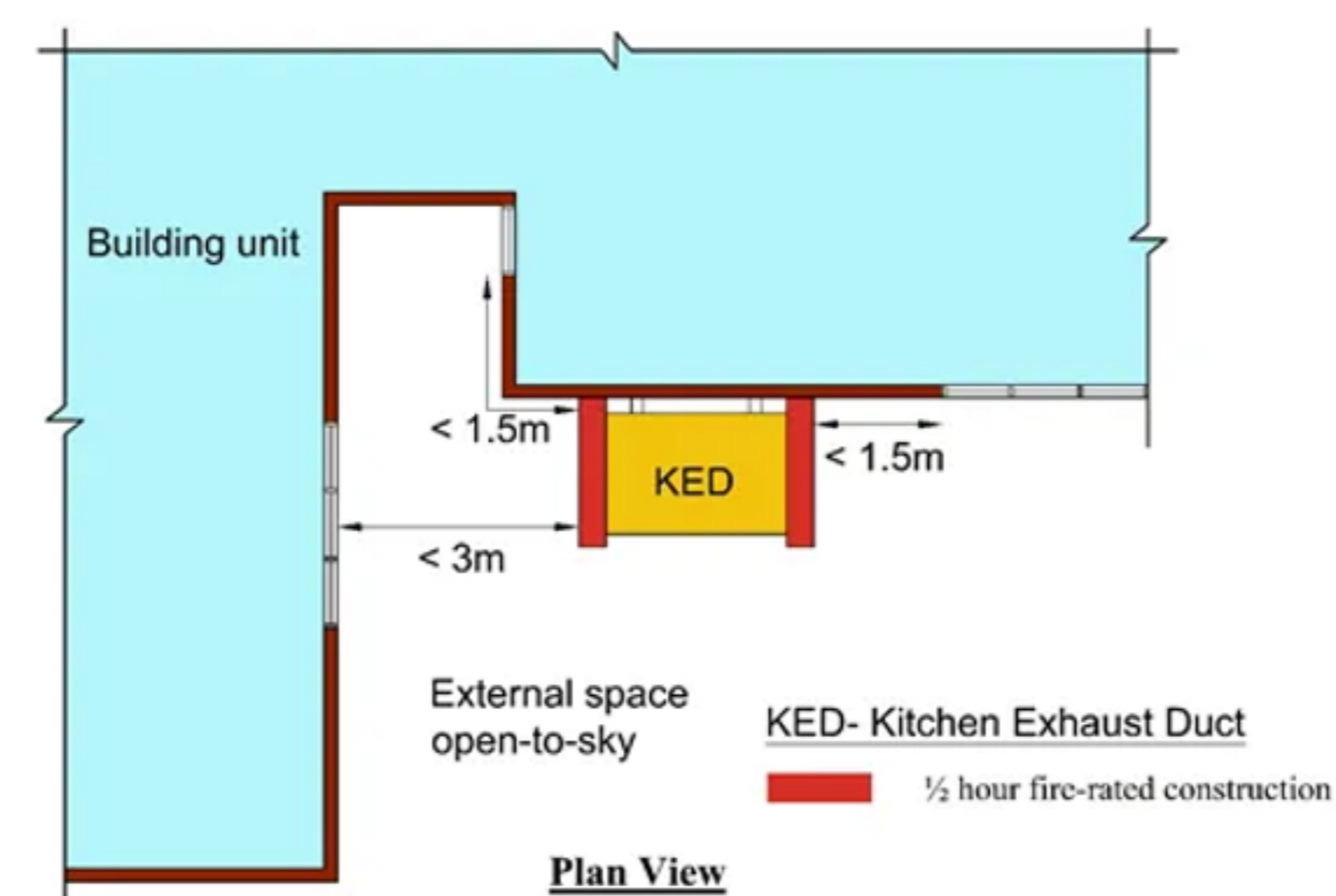

Diagram 7.1.12c(2): Fire resistance construction for kitchen exhaust duct

Diagram 7.1.12c.(3): Installation of non-fire-rated kitchen exhaust duct above LPG cylinders

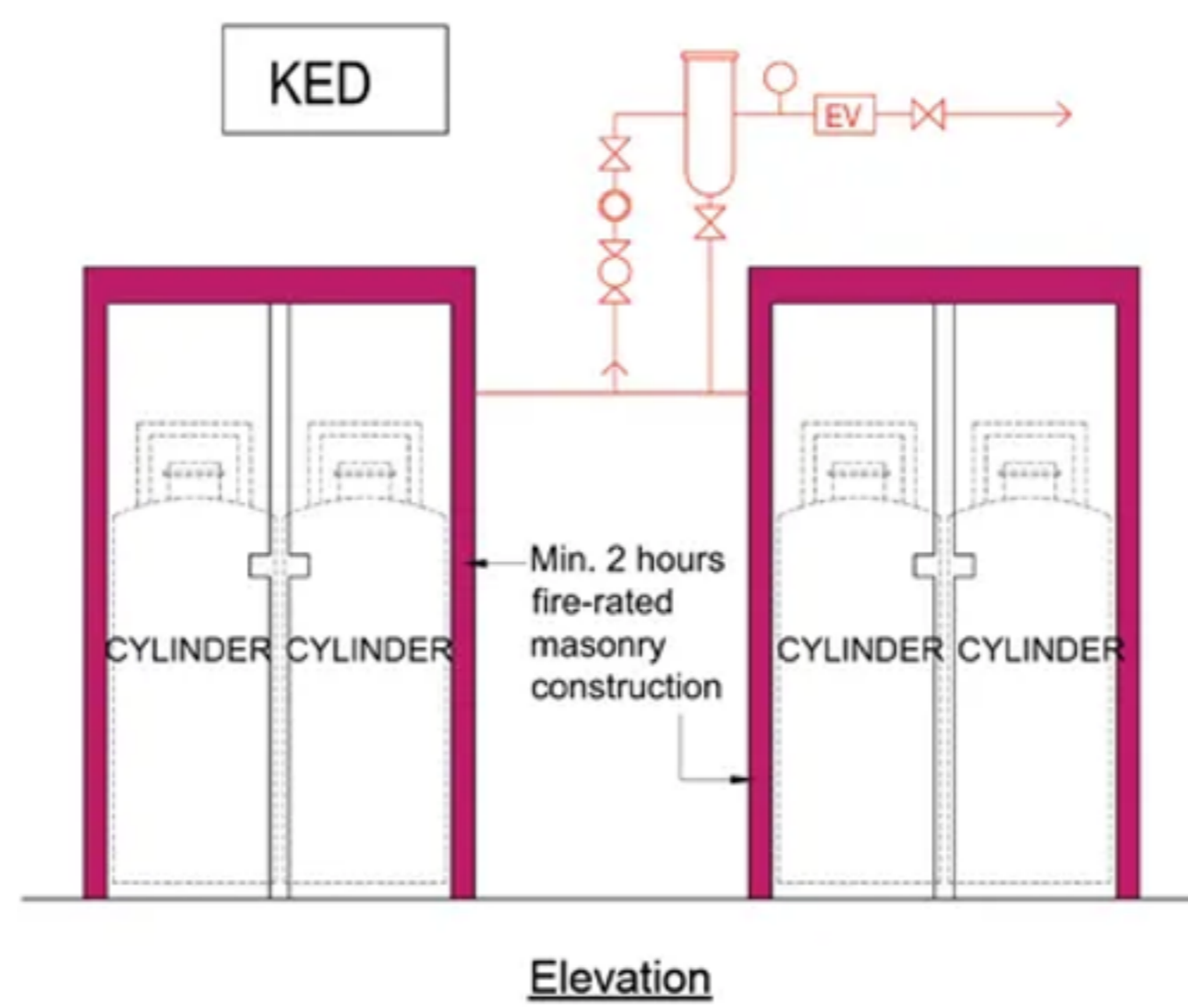

Diagram 7.1.12c(3): Installation of non-fire-rated kitchen exhaust duct above LPG cylinders

Diagram 7.1.12c.(4): Installation of non-fire-rated kitchen exhaust duct in close proximity to LPG cylinders and vapouriser

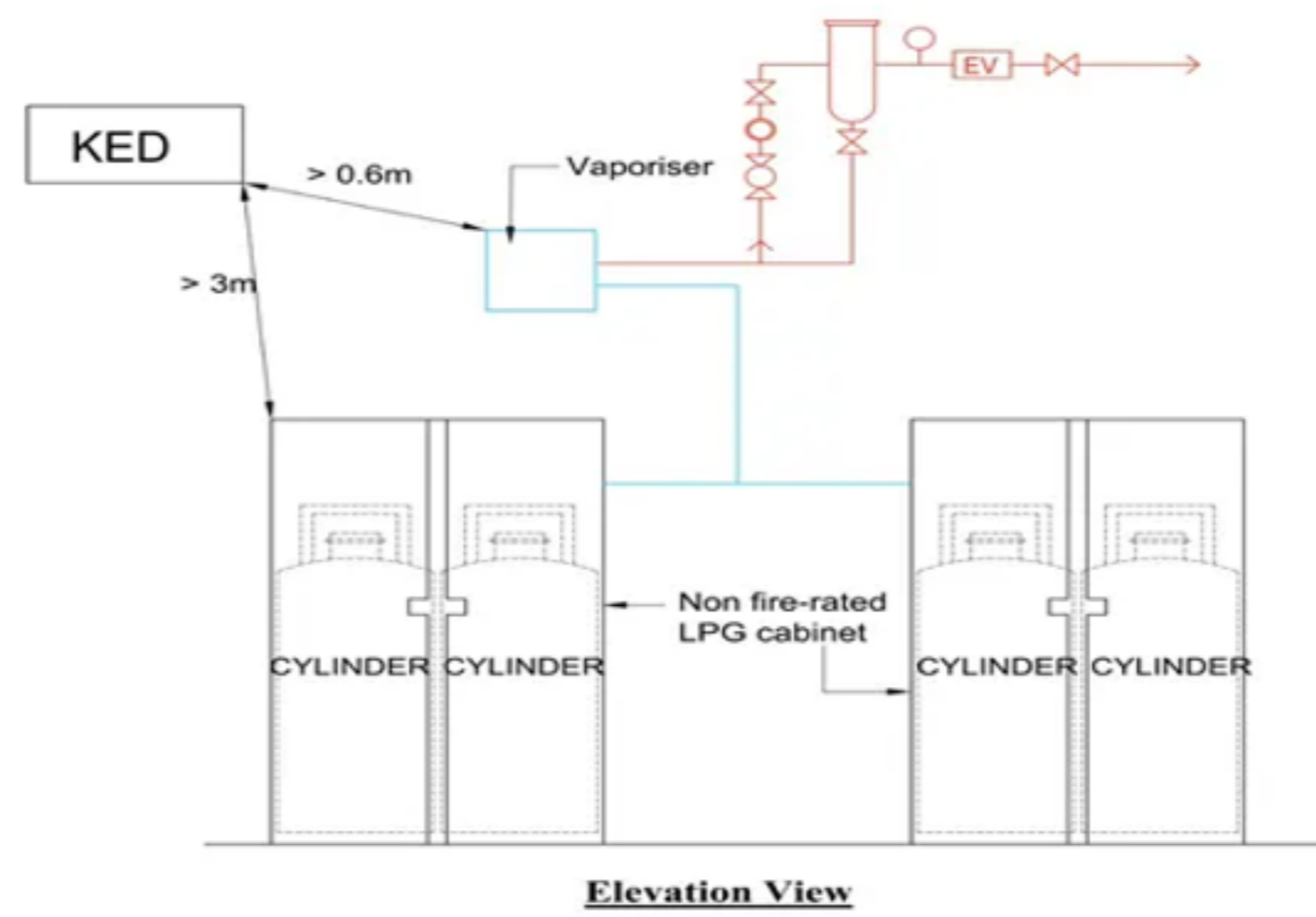

Diagram 7.1.12c(4): Installation of non-fire-rated kitchen exhaust duct in close proximity to LPG cylinders and vapouriser

Diagram 7.1.16 - 1: Air Shaft Plan Layout

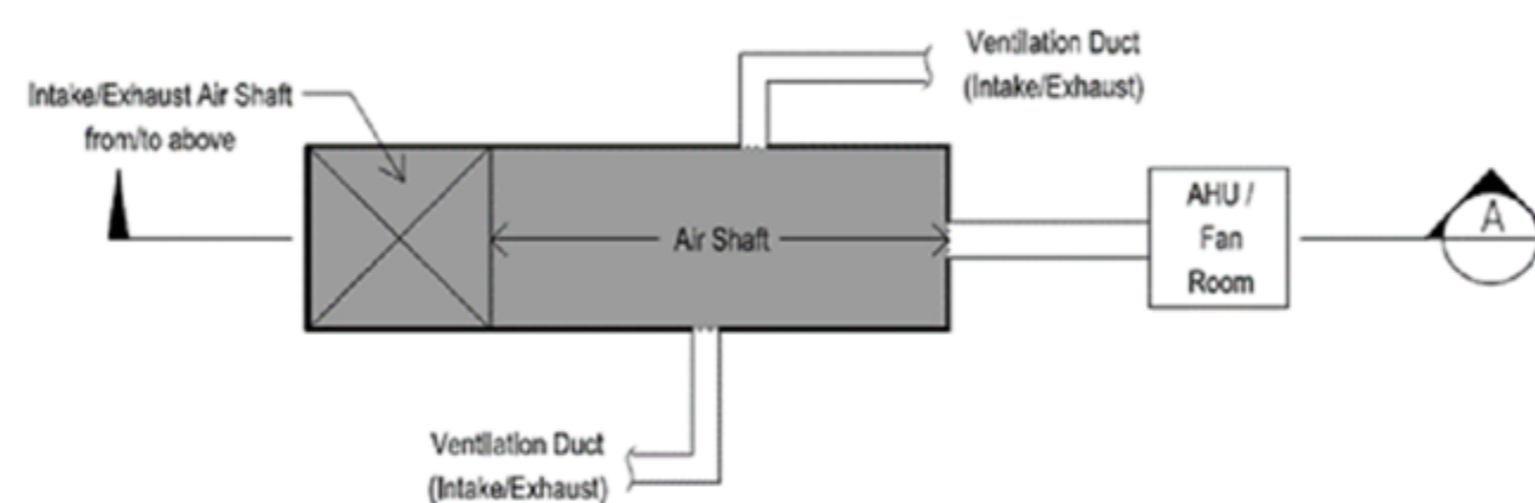

Diagram 7.1.16 - 1: Air Shaft Plan Layout

Diagram 7.1.16 - 2: Air Shaft Section A-A

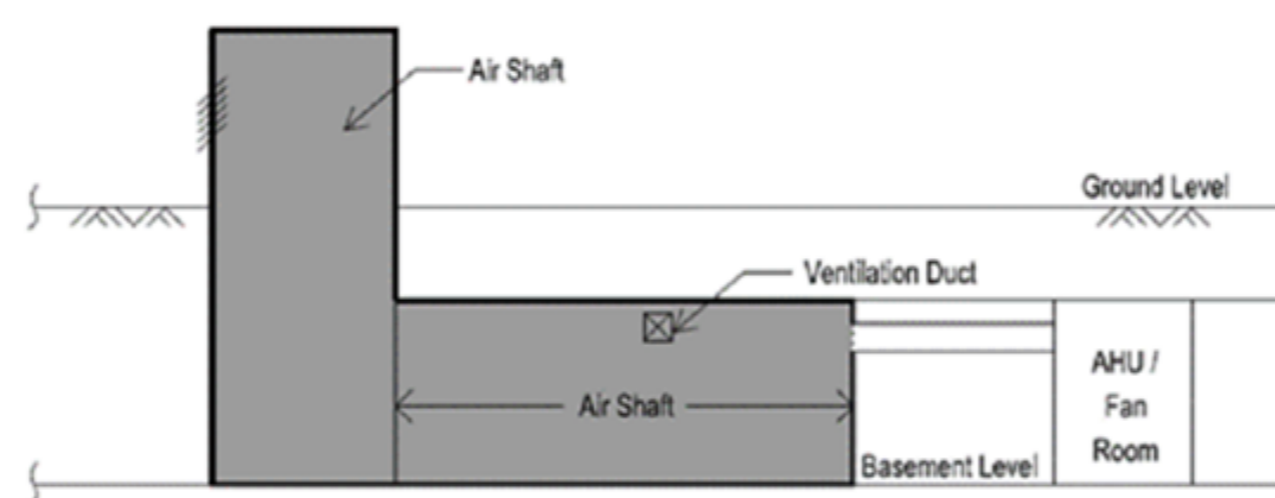

Diagram 7.1.16 - 2: Air Shaft Section A-A

TABLE 7.1.16: TYPES OF PERMITTED SERVICES ROUTED IN AIR SHAFTS

TABLE 7.1.16: TYPES OF PERMITTED SERVICES ROUTED IN AIR SHAFTS	
VENTILATION SUPPLY (VS) SHAFT	
1	Breeching inlet pipes for fire protection system.
2	Water metal pipes for domestic/ CD water supply, hydrant, and sprinkler.
3	Condenser water supply and return, condensate recovery metal pipes for aboveground cooling towers.
4	Water metal pipes for feed & expansion tank and cooling tower make up water tank.
VENTILATION EXHAUST (VE) SHAFT	
1	Sanitary waste and vent metal pipes (ejector and inspection chambers)
2	Pump drainage metal pipes
3	Fuel and vent pipes (in fire-rated enclosure) for day and bulk tank (for CD station only)
4	CD generator insulated exhaust metal pipes (for CD station only)
5	Low smoke zero halogen (LSOH) fire resistant or LSOH flame retardant earth cables for fuel inlet earth bar (for CD station only)
6	Non-flammable insulated refrigerant metal pipes and LSOH fire resistant or LSOH flame retardant cables for split air-conditioning units
7	LSOH fire resistant or LSOH flame retardant power & control cables for aboveground cooling towers
8	LSOH fire resistant or LSOH flame retardant power cables for mobile genset connection

9	Communication LSOH fire resistant cables running in metal conduits or trunkings for firefighter's intercom.
10	LSOH fire resistant or LSOH flame retardant power cables for battery room
11	Insulated chilled water supply and return metal pipes

ANNEX 7A - TENABLE ENVIRONMENT

A.1 General

The purpose of this appendix is to provide fire safety requirements for the details of the tenable environment.

A.2 Environmental Consideration

Some factors that shall be considered in maintaining a tenable environment for periods of short duration are defined as follows:

A.2.1 Heat effects

Exposure to heat can lead to life threat three basic ways:

- Hyperthermia
- Body surface burns
- Respiratory tract burns

For use in the modelling of life threat due to heat exposure in fires, it is necessary to consider only two criteria – the threshold of burning of the skin and the exposure at which hyperthermia is sufficient to cause mental deterioration and thereby threaten survival.

Note that thermal burns to the respiratory tract from inhalation of air containing less than 10% by volume of water vapor do not occur in the absence of burns to the skin or the face; thus, tenability limits with regard to skin burns normally are lower than for burns to the respiratory tract. However, thermal burns to the respiratory tract can occur upon inhalation of air above 60°C that is saturated with water vapor.

The tenability limit for exposure of skin to radiant heat is approximately 2.5 kW/m². Below this incident heat flux level, exposure can be tolerated for 30 minutes or longer without significantly affecting the time available for escape. Above this threshold value, the time to burning of skin due to radiant heat decreases rapidly according to equation (1).

$$(1) t_{\text{rad}} = 4q^{-1.35}$$

where: t_{rad} = time in minutes

q = radiant heat flux in kW/m²

As with toxic gases, an exposed occupant can be considered to accumulate a dose of radiant heat over a period of time. The fraction equivalent dose (FED) of radiant heat accumulated per minute is the reciprocal of t_{rad} .

Radiant heat tends to be directional, producing localised heating of particular areas of skin even though the air temperature in contact with other parts of the body might be relatively low. Skin temperature depends on the balance between the rate of heat applied to the skin surface and the removal of heat subcutaneously by the blood. Thus, there is a threshold radiant flux below which significant heating of the skin is prevented but above which rapid heating occurs.

Based on the preceding information, it is estimated that the uncertainty associated with the use of equation (1) is ±25%. Moreover, an irradiance of 2.5 kW/m² would correspond to a source surface temperature of approximately 200°C, which is most likely to be exceeded near the fire, where conditions are changing rapidly.

Calculation of the time to incapacitation under conditions of exposure to convected heat from air containing less than 10 percent by volume of water vapor can be made using either equation (2) or equation (3).

As with toxic gases, an exposed occupant can be considered to accumulate a dose of convected heat over a period of time. The FED of convected heat accumulated per minute is the reciprocal of t_{conv} .

Convected heat accumulated per minute depends on the extent to which an exposed occupant is clothed and the nature of the clothing. For fully clothed subjects, equation (2) is suggested:

$$(2) t_{\text{conv}} = (4.1 \times 10^8) T^{-3.61}$$

where: t_{conv} = time in minutes

T = temperature in °C

For unclothed or lightly clothed subjects, it might be more appropriate to use equation (3):

$$(3) t_{\text{conv}} = (5 \times 10^7) T^{-3.4}$$

where: t_{conv} = time in minutes

T = temperature in °C

Equations (2) and (3) are empirical fits to human data. It is estimated that the uncertainty is ±25%.

Thermal tolerance data for unprotected human skin suggest a limit of about 120°C for convected heat, above which there is, within minutes, onset of considerable pain along with the production of burns. Depending on the length of exposure, convective heat below this temperature can also cause hyperthermia.

The body of an exposed occupant can be regarded as acquiring a “dose” of heat over a period of time. A short exposure to a high radiant heat flux or temperature generally is less tolerable than a longer exposure to a lower temperature or heat flux. A methodology based on additive FEDs similar to that used with toxic gases can be applied. Providing that the temperature in the fire is stable or increasing, the total fractional effective dose of heat acquired during an exposure can be calculated using equation (4):

(4)

$$\text{FED} = \sum_{t_1}^{t_2} \left(\frac{1}{t_{\text{rad}}} + \frac{1}{t_{\text{conv}}} \right) \Delta t$$

Note 1: In areas within an occupancy where the radiant flux to the skin is under 2.5 kW/m², the first term in equation (4) is to be set at zero.

Note 2: The uncertainty associated with the use of this last equation would be dependent on the uncertainties with the use of the three earlier equations.

The time at which the FED accumulated sum exceeds an incapacitating threshold value of 0.3 represents the time available for escape for the chosen radiant and convective heat exposures.

A.2.2 Air carbon monoxide content

Maximum of 2000ppm (parts per million) for a few seconds, averaging 1500ppm or less for the first 6 mins of the exposure, averaging 800ppm or less for the first 15 mins of the exposure, averaging 50ppm or less for the remainder of the exposure.

A.2.3 Smoke obscuration levels

Smoke obscuration levels shall be continuously maintained below the point at which a sign internally illuminated at 80 lux is discernible at 30m and doors and walls are discernible at 10m. This is equivalent to a light attenuation coefficient of 0.267 per m.

A.2.4 Air velocities

Air velocities in the enclosed trainway shall be greater than or equal to 0.76m/s and less than or equal to 11.18m/s.

A.2.5 Noise levels

Maximum of 115dBA for a few secs, maximum of 92dBA for the remainder of the exposure.

A.3 Geometric Consideration

Some factors that shall be considered in establishing a tenable environment in stations are as follows:

A.3.1 Smoke layer height

The evacuation path requires a height clear of smoke of at least 2m. The current precision of modelling methods is within 25%. Therefore, in modelling methods a height of at least 2.5m shall be maintained above any point along the surface of the evacuation pathway.

A.3.2 Zone of tenability

The application of tenability criteria at the perimeter of a fire is impractical. The zone of tenability shall be defined to apply outside a boundary away from the perimeter of the fire. This distance will be dependent on the fire heat release rate and could be as much as 30m.

Clause No.	Amendment Date	Effective Date	Clause Status	Clause Before Amendment	Circular Date
------------	----------------	----------------	---------------	-------------------------	---------------

CLAUSE 8.1 EXIT LIGHTING AND EXIT SIGN

8.1.1 Exit lighting

Rationale

The exit lighting shall be positioned so that the failure of any single lighting unit will not leave any area in darkness. For essential areas such as exit staircases, internal and external passageways, there shall be no interruption of illumination exceeding 1 sec during the changeover from one energy source to another. This will ensure occupants can see their way down via exit staircase without fear of tripping.

- a. Exits of all stations shall be provided with artificial lighting facilities to satisfy the requirements.
- b. The minimum illuminance to be provided for all exits and the spacing for luminaires shall be in accordance with the requirements in SS 563.
- c. The delay between the failure of the electrical supply to normal lighting and the energization of the exit lighting shall not exceed 1 sec.

8.1.2 Emergency lighting for public areas, corridors, and lobbies

- a. Emergency lighting shall be provided in public areas, all corridors, and lobbies
- b. The minimum level of illuminance, the spacing of luminaires, and the maximum delay for emergency lighting required in this clause shall be the same as that for the exit lighting.

8.1.3 Emergency lighting for occupied area

- a. Emergency lighting shall be provided in the occupied areas following the requirements below:
 - (1) Along paths leading to corridors, lobbies and exits in all occupied areas where the direct distance from the entry point of the corridor, lobby or exit to the furthest point in the area concerned exceeds 13m; or
 - (2) Over the whole of such area if there are no explicit paths leading to corridors, lobbies, and exits.
- b. Notwithstanding the requirements in [Cl.8.1.3a.](#) above, emergency lighting shall be provided in the following locations:
 - (1) Lift cars as stipulated in this Code;
 - (2) FCC;
 - (3) Generator rooms;
 - (4) Fire pump rooms;
 - (5) Accessible services ducts and cable chambers; and
 - (6) Areas of refuge within the station.
- c. The minimum level of illuminance shall comply with the requirements in SS 563.
- d. The delay between the failure of the electrical supply to normal lighting and the energization of the emergency lighting for occupied areas shall not exceed 15 secs.

Rationale

The emergency lighting enable the occupants/ maintenance personnel in the mentioned locations to evacuate safely in times of power failure. In addition, the emergency lighting will help firefighters to gain access into any of these rooms or spaces for firefighting or operations purposes.

8.1.4 Emergency lighting for firefighting facilities

Rationale

The purpose of illuminating these locations is to facilitate the occupants and/ or fire fighters to readily locate fire protection devices and firefighting equipment when normal power supply is interrupted during a fire emergency.

- a. Main and sub alarm panels, manual call points, and firefighting equipment shall always be adequately illuminated so that they can be readily located.
- b. The minimum level of illuminance shall comply with the requirements in SS 563.
- c. The delay between the failure of the electrical supply to normal lighting and the energization of the emergency lighting for firefighting facilities shall not exceed 15 secs.

8.1.5 Secondary source of power supply

- a. The delay for energization of the exit and emergency lighting systems between normal supply and the secondary source shall be as stipulated in the relevant clauses.
- b. Duration of the secondary source of power supply shall comply with the requirements in SS 563.
- c. Location, arrangement and control, installation of electrical wiring of the secondary source of supply, be it in the form of battery, stand by generator, inverter, or other accepted equipment shall comply with the requirements in SS 563.

8.1.6 Luminaries

All exits and emergency luminaires required by the Code shall be of approved type as specified in SS 563.

8.1.7 Exit and directional signs

- a. Exit signs
 - (1) The entrance to every exit on every floor shall be clearly indicated by an exit sign placed over the exit door. Such signs shall be placed so as to be clearly visible at all times.
 - (2) Exit sign shall be provided over all exit access doors for rooms with more than one door. See [Diagram 8.1.7a\(2\)](#).
 - (3) Exemption
Exit sign is not required under the following situations:
 - (a) Room provided with emergency lighting
 - (i) When a room is provided with only one door. See [Diagram 8.1.7a\(3\)\(a\)\(i\)](#), or
 - (ii) When a room or internal space is fully open towards an external corridor or the external of a station.
 - (b) Room without emergency lighting
 - (i) When a room is provided with only one door and the direct distance from the furthest distance in the room to the exit access door is 7m or less. See [Diagram 8.1.7a\(3\)\(b\)\(i\) – 1 & 2](#), or
 - (ii) When the furthest point in the room to the exit access door is 13m or less and the wall of the room comprises not less than 50% clear glazing facing (as shown in [Diagram 8.1.7a\(3\)\(b\)\(ii\)](#)):
 - an internal corridor covered by emergency lighting, or
 - an external corridor, or
 - the external of the station.
 - (iii) When an internal space is fully open towards an external corridor or the external of a station.
- b. Directional signs
 - (1) In long corridors, in open floor areas, and in all situations where the location of the exits is not readily visible, directional signs shall be provided to serve as guides from all portions of the corridors or floors. See [Diagram 8.1.7b\(1\)](#).
 - (2) In rooms where the line of sight to the exit access door is obstructed, directional sign shall be provided.

c. Electrically powered exit and directional signs

The legends, dimensions, design, and installation of the exit signs and directional signs shall comply with SS 563 and SS 508. Either graphic or text format can be used for the design of the signage. Externally illuminated exit signs shall comply with SS 563.

Exception: Externally illuminated exit signs in normally non-occupied plant rooms need not be lighted at all times. However, during power failure, the emergency lighting in the rooms shall provide the required illumination to the signs.

d. Self-illuminating signs

Self-illuminating fire safety signs complying with BS 5499: Part 2 can be used in lieu of emergency signs powered by electricity. The use of self-illuminating exit signs and directional signs powered by radioactive material are permitted in stations provided, the signs comply with UL 924, SS 563, and SS 508 (Part 1, 2, 3, & 5). Either graphic or text format can be used for the design of the signage. In addition, SS 563 Part 1 shall be complied with for determination of the viewing distance with distance factor (Z) fixed at 50.

e. Exit signs in metal enclosures with matt finishes are permitted with openings for venting, testing, and inspection.

f. Under-platform services ducts and cable chamber can use non-illuminated exit signs and directional signs (e.g. sticker type) that are in compliance with SS 508. Non-illuminated exit signs shall also be fixed next to the cat-ladder access.

8.1.8 Photoluminescent marking/ tape

Rationale

The provision of photoluminescent marking/ tape was introduced to eliminate total darkness scenario where all essential emergency lighting failed during a fire emergency.

a. Photoluminescent marking/ tape to guide occupants along evacuation routes to appropriate exit shall be provided:

- (1) along internal walls and/ or floors of the exit staircase, smoke-free lobby, and fire lift lobby;
- (2) on the doors of smoke-free lobby, fire lift lobby, and exit staircase; and
- (3) along corridor with exit directional signs.

b. The width of photoluminescent marking or tape shall be at least 50mm and be placed at low level. The bottom of the low level sign shall not be less than 150mm or more than 400mm above the floor level.

c. Omission of photoluminescent marking/ tape is permitted on the following conditions:

- (1) the emergency power supply of the exit lightings, exit signs, and directional signs in the above locations shall be a self-contained battery pack (single point emergency lighting system) in compliance with SS 563 or central battery supply.
- (2) there shall be at least 2 emergency luminaires in the smoke-free lobby, fire lift lobby and corridor with exit directional signs such that no part of such spaces shall be left in total darkness should there be failure of any one of the emergency luminaires.
- (3) there shall be at least one emergency luminaire at every exit staircase landing.

Note: Single point (emergency lighting) system – A system of emergency lighting employing self-contained emergency luminaires.

CLAUSE 8.2 EMERGENCY VOICE COMMUNICATION SYSTEM

8.2.1 Provision

One and two-way emergency voice communication shall comply with requirements stipulated in SS 546 with the following exceptions.

- Provisions of the two-way emergency voice communications system shall only be required for underground station. Locations of remote handsets for two-way emergency voice communications system shall comply with [Cl.8.2.7](#).
- 4-hrs backup battery capacity for the emergency voice communication system shall be provided. The backup battery capacity can be halved if it is supported by a dual feeder power supply.

8.2.2 One-way emergency voice communication system

Except for lift cars, one-way emergency voice communication system shall be provided throughout the station including all habitable rooms, basement floor areas, commercial spaces, escape staircases, all lobbies forming parts of the means of escape, main entrance lobby, corridors leading to exits, ancillary areas where people are working, area of refuge and assembly areas in compliance with SS 546.

8.2.3 Overriding of one-way emergency voice communication system

The Passenger Service Centre (PSC) or in the absence of which, the Operation Control Centre (OCC) shall be able to override the one-way emergency voice communication System in the commercial spaces on commercial floor.

8.2.4 Sounding of alarm bell

The sounding of the alarm bells in the ancillary areas and the commercial spaces on commercial floor can be interrupted by messages made through the one-way voice communication system. However, the alarm bells shall resume sounding not longer than 10 secs after the broadcast of messages.

8.2.5 Interface with fire alarm system

The one-way emergency voice communication system shall interface with the fire alarm system in compliance with SS 546 and SS 645. When fire alarm system is activated:

- a fire alarm sounding shall be operated for at least 15 secs with a manual or automatic switching facility provided to silence all alarm sounders. The alarm sounders shall be silenced once an alert message is being broadcast. The alert message shall be broadcast for a minimum of two cycles and continue until manually silenced or superseded manually or automatically by the evacuation message, or by a second alert message.
- in the event of subsequent alarm activation from other alarm zones, the first emergency announcement shall be replaced by a higher priority or evacuation announcement initiated from the fire alarm system or manually from the emergency voice communication system.
- when an emergency announcement has been initiated automatically from the fire alarm system, the first emergency announcement shall be replaced by a higher priority announcement or an evacuation announcement from the emergency voice communication system after at most 8 mins of announcement and no manual acknowledgement by the transit station operators.

8.2.6 Emergency fire phones

Rationale

The emergency fire phones' location is part of the escape routes used by passengers for reporting of any fire incident expeditiously.

Emergency fire phones (a two-way voice communication system) shall be provided in lieu of manual call points in the station public areas such that a person does not need to travel more than 90m to an emergency fire phone on any level except platform to report a fire. The PSC, where provided, can be considered as a reporting station. At platform level, emergency fire phones shall be located one on each side of the platform near or next to all the escalator landings. See [Diagram 8.2.6](#).



Diagram 8.2.6: Location of Emergency Fire Phone

8.2.7 Two-way emergency voice communication

Rationale

Apart from the specific spaces stipulated in the clause, where the two-way emergency voice communication system must be located, it must also be near the equipment control panels to facilitate control of the equipment(s).

For underground station, two-way emergency voice communication shall be provided between the FCC or in the absence of which, the main alarm panel and the following:

- Every fire lift lobby including 1st storey;
- Fire pump room;
- Fire lift;
- Local manual control for smoke control equipment;
- All lift motor rooms;
- PSC;
- Air-handling control rooms if a manual on/ off switch for the station's central air-conditioning system is not provided in the PSC;

(Where AHU can be remotely monitored and controlled at the FCC, and cannot be by-passed locally, and the electrical cabling between AHU rooms and FCC are fire-rated, the two-way emergency voice communication system can be exempted.)

- Each area of refuge; and
- Smoke-free lobby serving firefighting staircase.

8.2.8 Firefighters' intercom

Rationale

The firefighters intercom shall be co-located near the access stairs at the platform leading to the track level. This is to facilitate communication between firefighters at the tunnel entry points in underground station and at ground level breaching inlet.

Firefighters' intercom shall be provided for communication between the tunnel dry mains breaching inlet at the ground level and the buffer areas. The intercom unit at the buffer areas shall be located near the access stairs at the platform leading to the track level. See [Diagram 8.2.8](#).

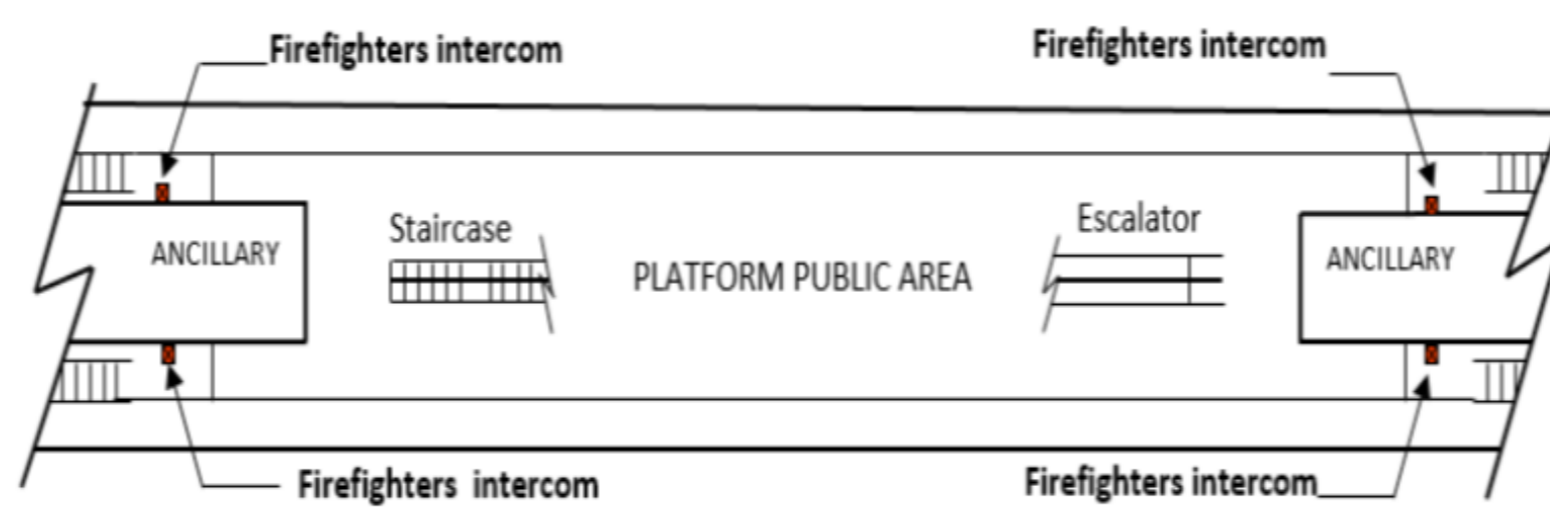

Diagram 8.2.8: Locations of Firefighters' Intercom at Platform Level

8.2.9 Radio communication

Rationale

In view that the frequency may deviate from time to time, the revised clause accords that flexibility.

Underground stations shall be provided with radio (voice and data) communication facilities capable of operating in the frequency band as allocated to SCDF and approved by authority having jurisdiction.

8.2.10 Stations with multiple transit lines

One-way emergency voice communication system for stations with multiple transit lines shall be designed in accordance with [CI.9.2.2](#).

8.2.11 Emergency fire phones and hotline telephones

a. In the PSC, emergency fire phones and hotline telephones which are required by the following clauses can be implemented as part of a central telephone console unit for voice communication:

- (1) [CI.8.2.6](#)
- (2) [CI.8.3](#)
- (3) [CI.9.2.2a](#).
- (4) [CI.9.2.3b](#).

b. Calls to the emergency fire phones and hotline telephones configured on the central telephone console shall not be blocked. The console shall not be inhibited from receiving new calls due to on-going calls.

c. Visual indication shall be provided to differentiate calls that are in-use, ringing, or on-hold.

CLAUSE 8.3 HOTLINE TELEPHONE BETWEEN STATIONS AND OCC

A hotline telephone (can be part of a central telephone console unit with button designated for hotline connection) shall be provided between each PSC, where provided, and the OCC. Hotline telephones in stations with interchange-link shall be provided in accordance with [Cl.9.2.3b](#).

CLAUSE 8.4 SIGNAGE FOR FIREFIGHTERS

Signage shall be provided on door to identify the room, space, or the area that the door leads into. Signage shall also be provided at strategic locations in underground transit station to guide firefighters entering the station from the exit/ firefighting staircase to every part of the station. The signage shall comply with SS 508.

CLAUSE 8.5 PLANS FOR FIREFIGHTERS

8.5.1 Location and plan details

Two paper sets of plans shall be kept next to the main alarm panel in a dedicated plan box marked "STATIONLAYOUT PLANS FOR FIREFIGHTERS" to help firefighters to navigate in the station. The plans shall:

- a. minimally be of A3 size;
- b. be without gridlines;
- c. have spaces clearly annotated;
- d. indicate the fire lift, firefighting staircase, exit staircase, fire lift lobbies, smoke-free lobbies, fire pump room, landing valves, Two-way Emergency Voice Communication handsets, and firefighters' intercoms in red; and
- e. be updated and in good condition at all times.

8.5.2 Plan Box

A locked glass-fronted plan box constructed of non-combustible material shall be provided and firmly mounted on wall. The key shall be kept in a glass-fronted box alongside the plan box or as part of the plan box. Signage complying with SS 508 shall be provided to read "IN CASE OF EMERGENCY, BREAK GLASS FOR KEYS". A spare key shall be kept in the PSC.

CLAUSE 8.6 FIRE COMMAND CENTRE

8.6.1 Provision

- a. An FCC shall be provided for station with fire lift
- b. Size

An FCC shall be of adequate size to house all the terminals and supervisory/ control equipment etc. of the station's fire protection/ detection systems, as well as a free working space (unobstructed by door swing) of at least 6m² and minimum clear width of 2m.

Rationale

The minimum networking space of 6m² excludes spaces for equipment and furniture. When the FCC serves a multiple transit line station, the floor area of the FCC will need to be increased accordingly to accommodate additional supervisory panels.

c. Supporting equipment

An FCC is a room within a station dedicated to the controlling and monitoring of fire protection systems during a fire emergency. As such, equipment/ services not meant for this purpose shall not be located inside the FCC with exception of the following:

- (1) Lift supervisory panel.
- (2) Background music system connected to one-way emergency voice communication system rack.
- (3) Workstation/ server rack for security card access & CCTV system for security monitoring.
- (4) Workstation/ server rack for car park access control system.
- (5) Workstation/ server rack for fire alarm's colour graphics system.
- (6) Workstation/ server rack for BMS/ BAS monitoring and controlling other ACMV system.
- (7) Walkie-talkie charging stations.
- (8) UPS system with totally sealed battery capacity not exceeding 750Amp-hr.

d. Location

The FCC shall be located at the same level as the fire engine accessway/ fire engine access road and its entrance shall be located in the following order of priority:

- (1) It shall be within 5m from entrance of the fire lift lobby at the designated storey of the station.
- (2) In the case where there is no fire lift lobby, it shall be located within vicinity of the fire engine accessway or fire engine access road and within 5m from the entrance of one of the protected stairs serving all storeys of the development.
- (3) It shall be at any other location as may be designated by the SCDF.

Rationale

As the term "adjacent" previously used is ambiguous, it is replaced with specific distance for clarity. "5m" is considered a distance reasonably close to the fire lift lobby.

e. Construction

The construction of enclosure, facilities and lighting of an FCC shall comply with the SS 546.

8.6.2 Mechanical ventilation

Mechanical ventilation where required for the FCC, shall comply with:

- a. Air-conditioning and/ or mechanical ventilation where required for the FCC shall be provided with secondary power supply and shall be independent of each other and have ductworks independent of any other ductwork serving other parts of the station.
- b. The mechanical ventilation rate shall be 6 air change/hr.

Rationale

The purpose of having independent ductwork for the ACMV serving the FCC is to prevent fire or smoke from being conveyed into the FCC via the ducts.

- c. Supply air shall be drawn directly from the external/ air shaft; its intake point shall be arranged with exhaust outlets to avoid re-circulating of air/ smoke back into the room.
- d. Where the corresponding ducts run outside the FCC, they shall either be enclosed in a structure or constructed to give at least the same fire rating as the room which they serve or that of the room through which they traverse, whichever is higher.
- e. No fire damper shall be fitted in either the supply or exhaust duct required under this clause.
- f. Duct serving areas other than the FCC shall not pass through the FCC.

Diagram 8.1.7a.(2)

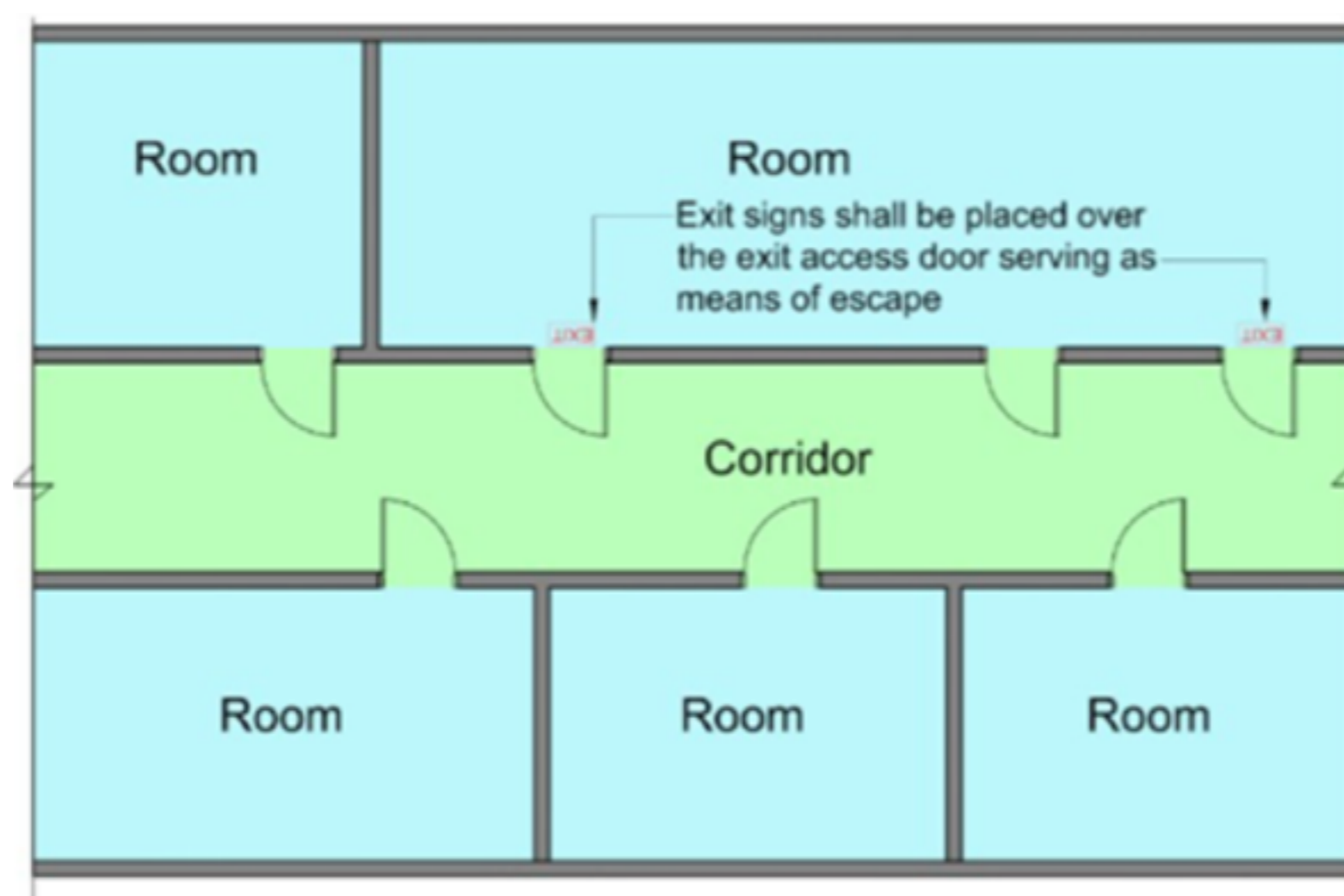

When a room is provided with more than one door, exit signs shall be provided over the exit access doors intended to be used as means of escape.

Diagram 8.1.7a.(2)

Diagram 8.1.7a.(3)(a)(i)

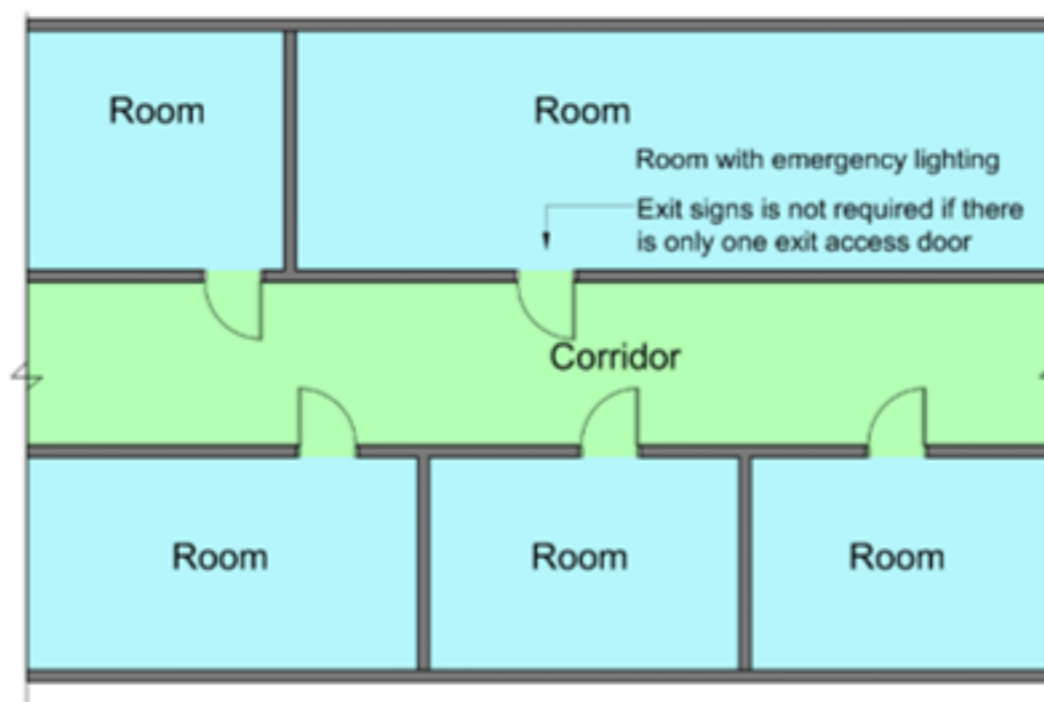

When an occupied space is provided with emergency lighting, exit sign is not required if there is only one exit access door.

Diagram 8.1.7a(3)(a)(i)

Diagram 8.1.7a(3)(b)(i) - 1

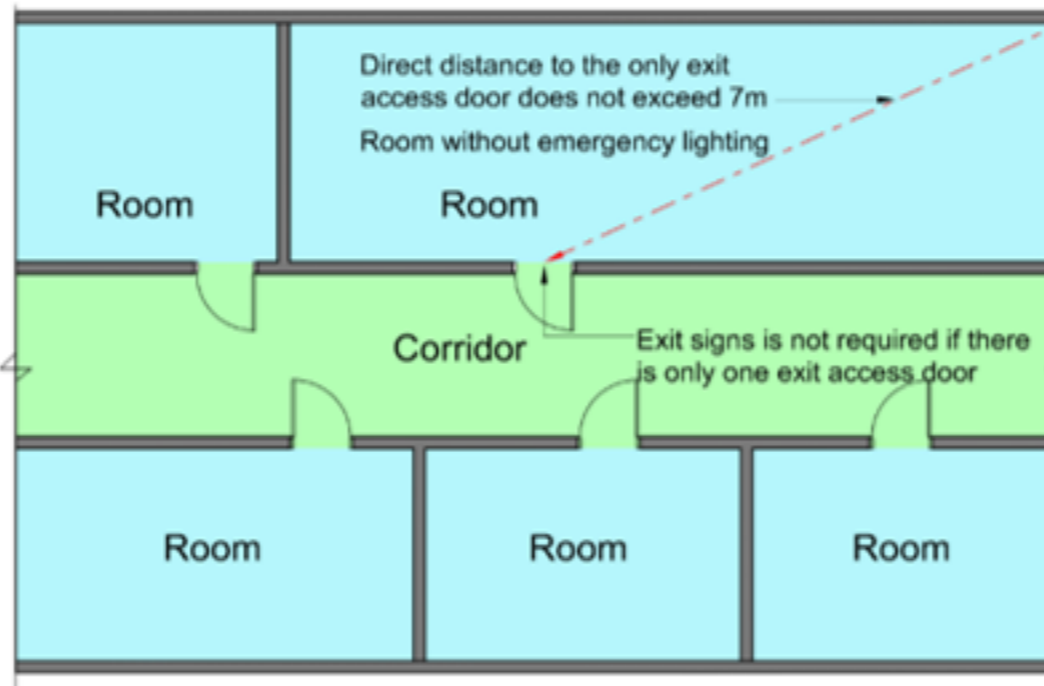

In a room without emergency lighting where the room is provided with only one door and the direct distance from the furthest distance in the room to the exit access door is 7m or less, exit sign is not required if there is only one exit access door.

Diagram 8.1.7a(3)(b)(i) - 1

Diagram 8.1.7a(3)(b)(i) - 2

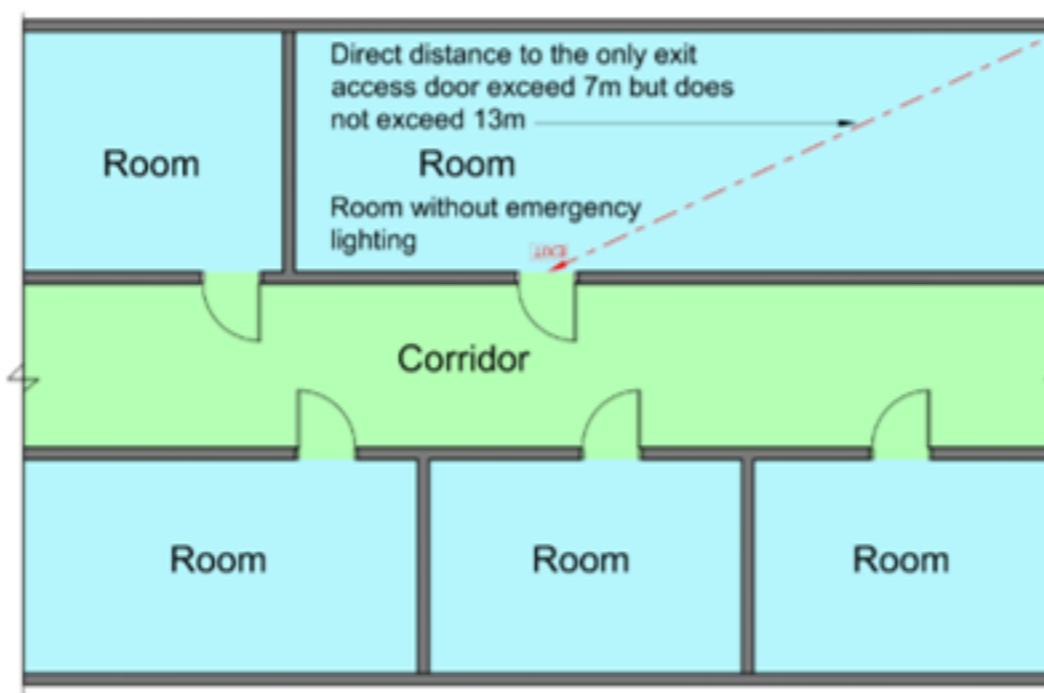

In a room without emergency lighting where the furthest point in the room to the exit access door exceeds 7m but does not exceed 13m, exit sign shall be provided over the door. Alternatively, the room can be provided with emergency lighting.

Diagram 8.1.7a(3)(b)(i) - 2

Diagram 8.1.7a(3)(b)(ii)

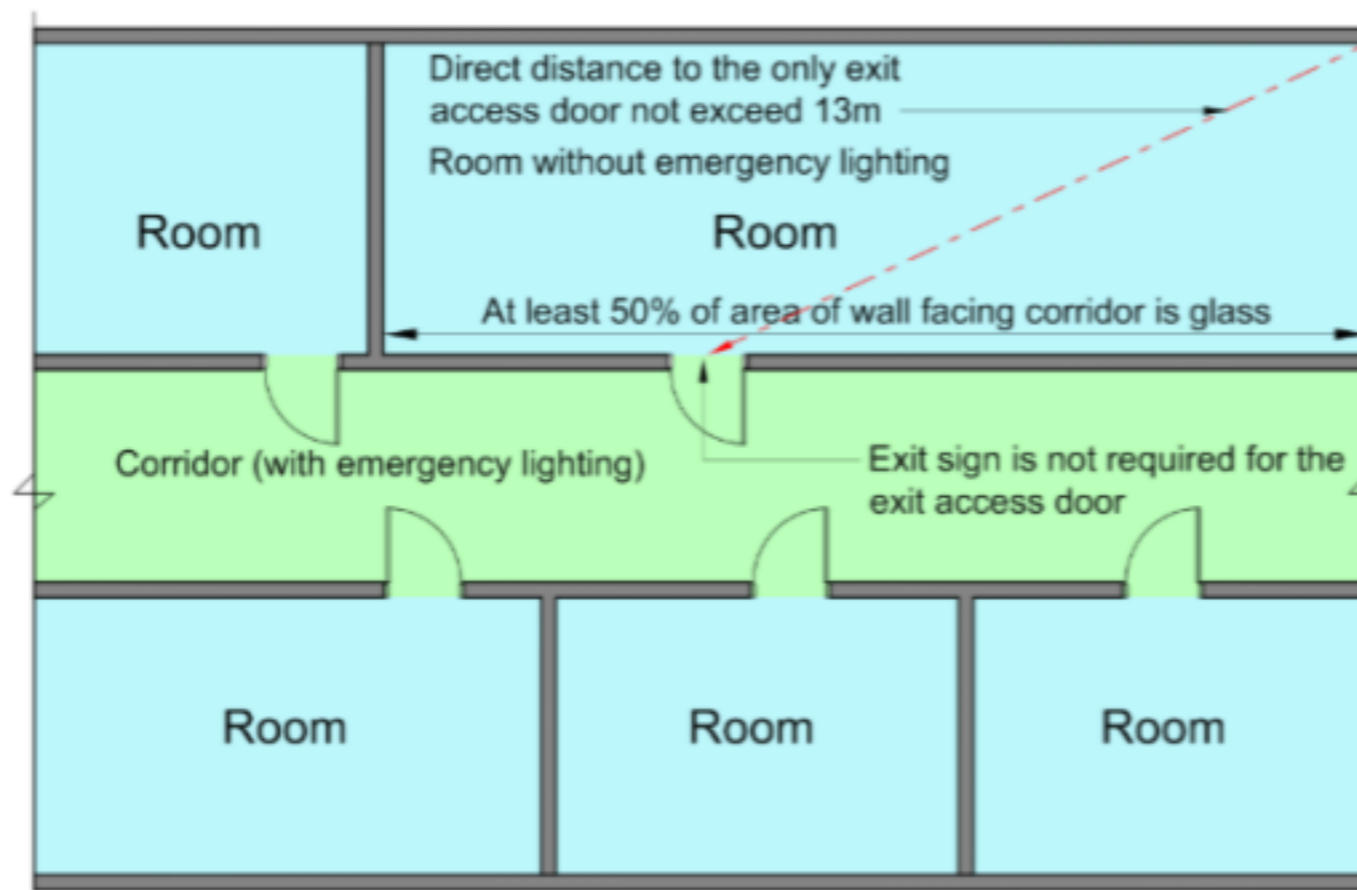

In a room without emergency lighting where the furthest point in the room to the exit access door is 13m or less and wall of the room comprises not less than 50% clear glazing facing:

- an internal corridor covered by emergency lighting
- an external corridor, or
- the external of the building.

Exit sign is not required to be provided over the exit access door.

Diagram 8.1.7a(3)(b)(ii)

Diagram 8.1.7b.(1): Location of directional signs

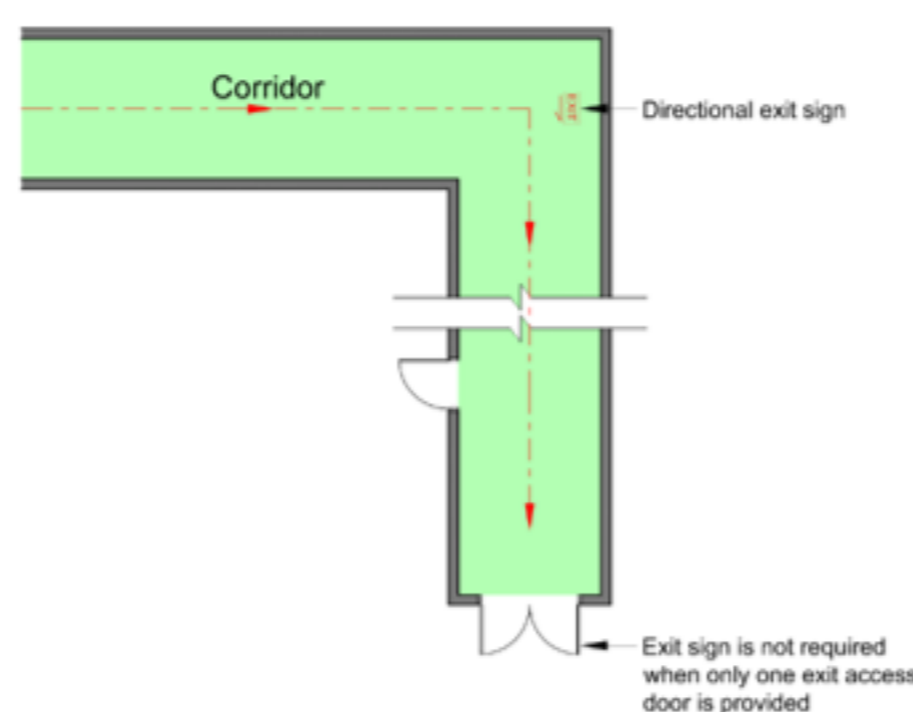

Diagram 8.1.7b.(1): Location of directional signs

Clause No.	Amendment Date	Effective Date	Clause Status	Clause Before Amendment	Circular Date
------------	----------------	----------------	---------------	-------------------------	---------------

CLAUSE 9.1 GENERAL

This Chapter specifies the additional requirements applicable to stations of respective occupancies. These additional requirements shall be read in conjunction with other requirements relevant to Chapter 1 to 8 of this Code. Where there are conflicting requirements between this chapter and the preceding chapters, the requirements stipulated in this chapter shall take precedence.

CLAUSE 9.2 INTEGRATION AND INTERFACE FOR STATIONS

9.2.1 Scope and purpose

This Section stipulates the minimum fire safety provisions required for stations that integrate and interface with other transit lines, transit stations, and non-transit occupancies.

9.2.2 Stations with multiple transit lines

a. Hot-line telephone

Hot-line telephone(s) shall be provided for two-way communication between the PSCs of these transit lines in the station or in the absence of PSCs, the OCCs. The installation shall comply with SS 546.

b. One-way emergency voice communication system

Where one-way emergency voice communication system is provided for the different transit lines within the station for their respective concourse and platform areas, this one-way emergency voice communication system shall be designed such that announcements can be made by one of the transit lines over all the one-way emergency voice communication systems in the station simultaneously during an emergency.

c. Fire alarm panel

One main fire alarm panel shall be provided in accordance with [Cl.6.3](#). Where separate fire alarm systems for the different transit lines are desirable, separate fire alarm panels may be provided. These fire alarm panels shall be located, in accordance with [Cl.6.3](#), next to each other.

9.2.3 Stations with interchange-link

a. Interchange-link shall not be included in the calculations of station exit capacity.

b. Hot-line telephone

Hot-line telephone(s) shall be provided for two-way communication between the PSCs of these stations, or in the absence of PSCs, the OCCs. The installation shall comply with SS 546.

c. Fire alarm signal

A summary fire alarm signal from each station shall be transmitted to the PSCs of the other stations connected by the interchange-link, or in the absence of PSCs, the OCCs. The transmission lines shall be electrically supervised. Upon receiving a summary fire alarm signal, an audible and visual alarm shall be activated at the PSCs or OCCs. A silencing switch can be provided to silence the audible alarm, but it shall not cancel the visual alarm.

9.2.4 Stations connected to non-transit occupancies

a. Underground station integrated with non-transit occupancy

Where an entrance of an underground station is integrated with a non-transit occupancy, the following shall be complied with:

(1) Station entrance

The entrance shall comply with the relevant fire safety requirements in other chapters of this Code.

(2) Fire separation

The entrance shall be fire separated from the non-transit occupancy with fire barriers having at least 2 hours fire resistance.

(3) Unprotected openings

There shall be no unprotected openings at the non-transit occupancy area within 3m of the ventilation openings located in the external wall of the entrance.

(4) Fire-rated shutters

Where fire-rated shutters are installed to provide the fire separation required in [Cl.9.2.4a.\(2\)](#), it shall be in accordance with [Cl.3.7.6d\(1\)](#).

b. Stations with underground link to non-transit occupancy

Where a station has an underground link connected to a non-transit occupancy, the following shall be complied with:

(1) Underground link

The link shall not be used as means of escape. The underground link shall be considered as part of the station and shall comply with the relevant fire safety requirements in other chapters of this Code.

(2) Fire-rated shutters

The station shall be separated from the non-transit occupancy by fire-rated shutters having at least 2-hrs fire resistance. The fire-rated shutters shall be in accordance with [Cl.3.7.6d\(1\)](#).

c. Station with elevated link to non-transit occupancy

Where a station has an elevated link/ overhead-bridge connected to a non-transit occupancy, the following shall be complied with:

(1) Elevated link.

The link shall not be used as means of escape. The elevated link shall be considered as part of the station and shall comply with the relevant fire safety requirements in other chapters of this Code.

(2) Where the elevated link is enclosed and provided with mechanical ventilation or air-conditioning, means shall be provided to prevent smoke generated from a fire in the non-transit occupancies to migrate into the station

CLAUSE 9.3 UNDERGROUND OR ENCLOSED TRAINWAY

9.3.1 Construction Materials

a. General

All underground or enclosed trainways including elements of structure of the trainways, cross-passageways, doors, and walk surface designated for evacuation of passengers shall be constructed of non-combustible materials.

b. Fire resistance of elements of structure

The fire resistance of the elements of structure for the underground or enclosed trainway shall be at least 4 hrs.

c. PVC pipes, conduits, and fittings

Except as permitted in [Cl.9.3.1f](#), exposed PVC pipes, PVC conduits and fittings are not allowed in the underground or enclosed trainway.

d. Vertical exit shafts and ventilation structures

The fire resistance of the elements of structure of remote vertical exit shafts and ventilation structures shall be at least 2 hrs. Test of fire resistance shall be in accordance with [Cl.3.4](#).

e. Ancillary areas

Ancillary areas shall be separated from the trainway areas within underwater line sections (such as those under the sea, reservoir, river, or canal) by at least 3-hrs fire-resistant construction. Ancillary areas shall be separated from the trainway areas within underground line sections by at least 2-hr fire-resistant construction.

f. Cover board

Cover board or any protective material used to provide safety isolation from the contact traction power rail shall have a flame spread rating of at least Class 1 as specified in [Cl.3.13.3](#) when tested in accordance with BS 476: Part 7.

9.3.2 Exits

a. Provision

Exits shall be provided from underground or enclosed trainways to a point of safety.

b. Exit staircases

Exit staircases shall be provided throughout the underground or enclosed trainways and spaced so that the distance between exit staircases is at most 760m. The staircase shall be enclosed and shall lead directly to the outdoors or to a safe refuge area. The minimum clear width of the staircase shall be 1m. Handrails shall be provided in accordance with [Cl.2.2.10f](#). The staircase shall be ventilated in accordance with [Chapter 7](#).

9.3.3 Escape via separated trainways

Where underground or enclosed trainways are divided by at least 2-hr fire-rated walls or where trainways are in twin bores, such an arrangement shall be deemed to afford adequate protection for the passengers via cross passageways between the trainways and shall be permitted to be utilised in lieu of exit staircases to the surface. The following shall apply:

a. The distance between a cross passageway and an exit staircase or the platform public area shall be at most 500m. See [Diagram 9.3.3a](#).

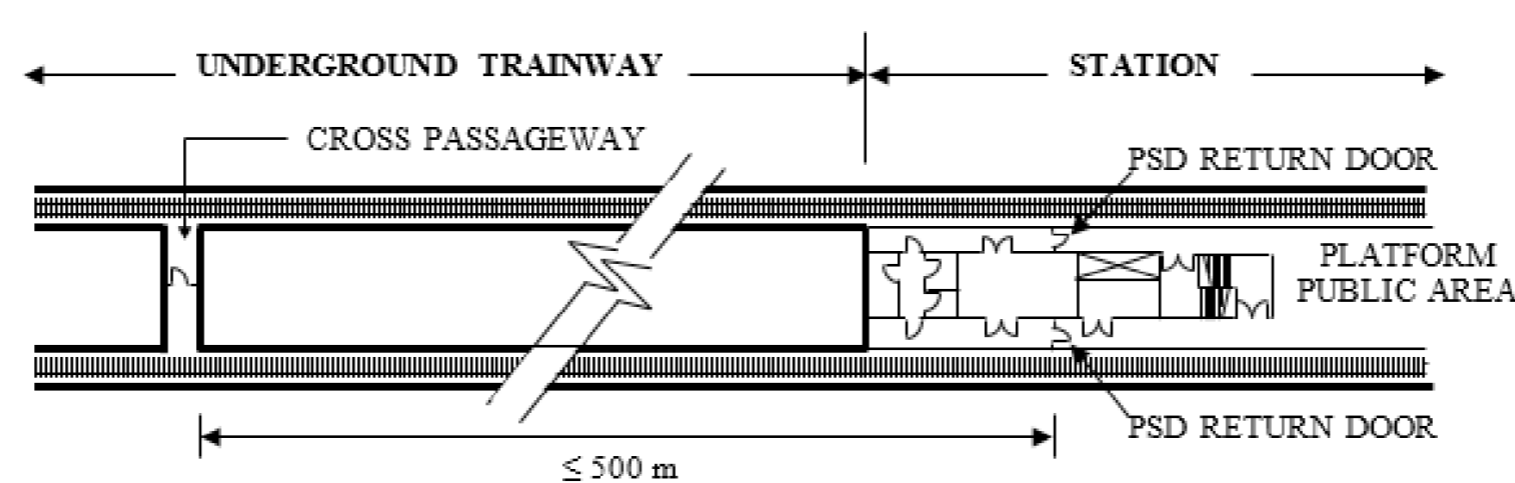

Diagram 9.3.3a: Location of First Cross-passageway in Underground Trainways

b. Cross-passageways shall be at most 250m apart.

c. Opening in cross passageway with a minimum clear width of 1m shall be protected with a fire door assembly having a fire resistance of at least 2-hrs with a self-closing device.

d. A non-contaminated environment shall be provided in that portion of the trainway that is not involved in an emergency and that is being used for evacuation.

e. A ventilation system for the contaminated trainway shall be designed to control smoke in the vicinity of passengers.

f. A suitable method shall be provided for evacuating passengers in the uncontaminated trainway, for protecting passengers from on-coming traffic, and for evacuating the passengers to a nearby station or another exit.

g. Where cross-over that breaks the fire separation between enclosed trainways is provided, the following conditions shall be complied with:

(1) The design of the emergency ventilation system shall also meet the requirements of [Cl.9.3.11e\(1\)](#) for the scenario where train fire occurs at the cross-over.

(2) Distance between the cross-passageways at upstream and downstream of the cross-over shall be at most 500m apart.

(3) Distance between the cross-over and the nearest cross passageway shall be at least 125m and at most 250m. See [Diagram 9.3.3g](#).

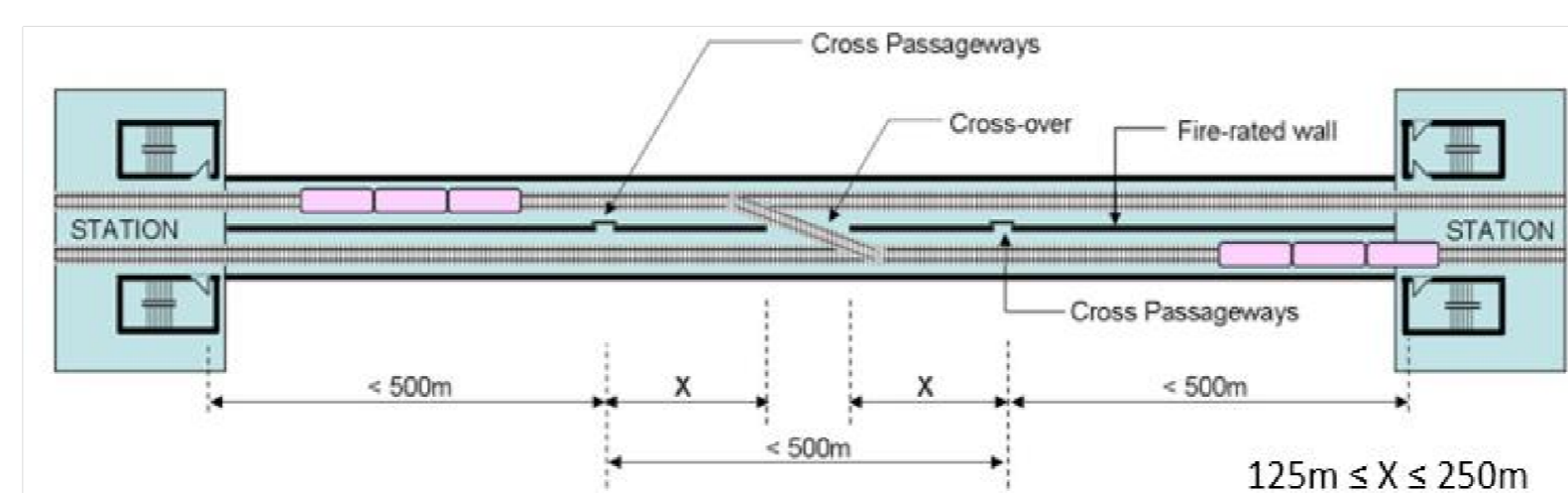

Diagram 9.3.3g: Cross-over Between Enclosed Trainways

9.3.4 Doors

Doors to an exit shall open in the direction of exit travel except in the case of cross-passageway closures. Doors to the exit access in the trainways shall be provided with a self-closing device but no locking device shall be provided. The force required to open the doors fully when applied to the latch side shall be as low as possible, not exceeding 220N. In addition, door and hardware shall be adequate to withstand the positive and negative pressures created by passing trains.

9.3.5 Emergency egress pathway

An effective emergency egress pathway of minimum 800mm width shall be provided. In areas with cross passageways, unobstructed access shall be provided to the cross passageways.

9.3.6 Surfaces of emergency egress pathway

The walking surfaces of the emergency egress pathway shall have a non-slip design.

9.3.7 Egress via trainway concreted track bed

Where the trainway concreted track bed serves as emergency egress pathway, it shall be nominally level, and free of obstructions. Where signalling equipment is located along the emergency egress pathway, ramp, and platform shall be provided. The edges of the ramp and platform shall be painted with bright yellow paint to enhance its visibility.

9.3.8 Exit signs and emergency lightings

a. General

Exit facilities shall be suitably identified and maintained to allow for their intended use.

b. Exit signs

Exit signs at exit staircases shall comply with the requirements as specified for stations in [Cl.8.1.7](#), whereas non-maintained illuminated exit signs at cross-passageways shall be designed to be remotely controlled to support the evacuation strategy.

c. Signage

Signage shall be provided to assist emergency evacuation of passengers. The signs shall be reflective or illuminated.

d. Emergency lighting

Emergency lighting shall be provided to underground or enclosed trainways exceeding 15m in length. The illumination level at walking surfaces shall be at least 2.7 lux.

e. Emergency power supply

The emergency lighting shall be connected to an emergency power supply capable of maintaining the minimum illumination level for at least 2 hrs.

f. Fire resistant cables

Fire resistant cables of at least 2-hr rating shall be used.

9.3.9 Fire protection systems

a. Dry rising mains

Underground or enclosed trainways shall be provided with dry rising mains. The dry main system and its associated water supply, control, and testing requirements shall be installed in accordance with SS 575, except as herein modified:

(1) Dry rising main system shall be provided in accordance with [Diagram 9.3.9a\(1\)](#) for the following areas:

- (a) Each underground trainway located between two stations;
- (b) Each underground or enclosed trainway between a station and the trainway portal; and
- (c) Each underground or enclosed reception or test track.

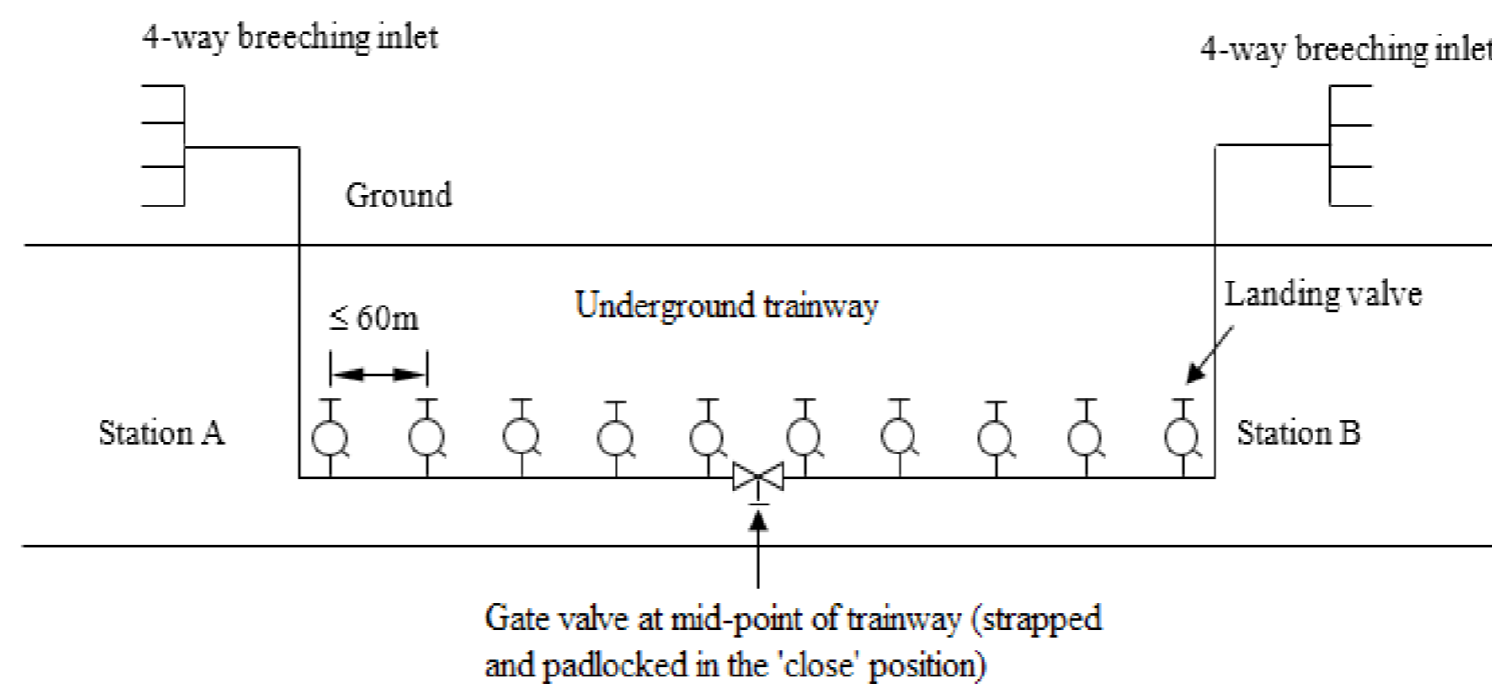

[Diagram 9.3.9a\(1\): Dry Main System in Underground or Enclosed Trainway](#)

(2) For over-run trainway, the dry rising main system can be served with only one breaching inlet at the station end.

(3) The nominal bore of the dry rising main shall be at least 150mm.

(4) The dry rising mains in the trainways need not be fire-rated.

(5) Landing valves shall be located at least 2m and at most 3m apart from exit staircases and cross passageways and shall be spaced at intervals at most 60m along the trainway.

(6) The first landing valve of the dry rising main after the breaching inlet shall be located at most 3m from the interface of the station box and the trainway. For the case of [Cl.9.3.9a\(1\)\(b\)](#), the first landing valve after the breaching inlet shall be located at most 3m from the portal.

(7) Where gaskets are used in pipe joints for dry rising mains serving different trainways but located in common TV vent shaft and TVF fan room, the gaskets shall be suitable for use in an ambient atmosphere of 250°C.

(8) Breaching inlets

The breaching inlets shall be located within 18m from the fire engine accessway and be visible from the fire engine accessway. Breaching inlets shall be appropriately numbered and labelled as shown in [Diagram 9.3.9a\(8\)](#).

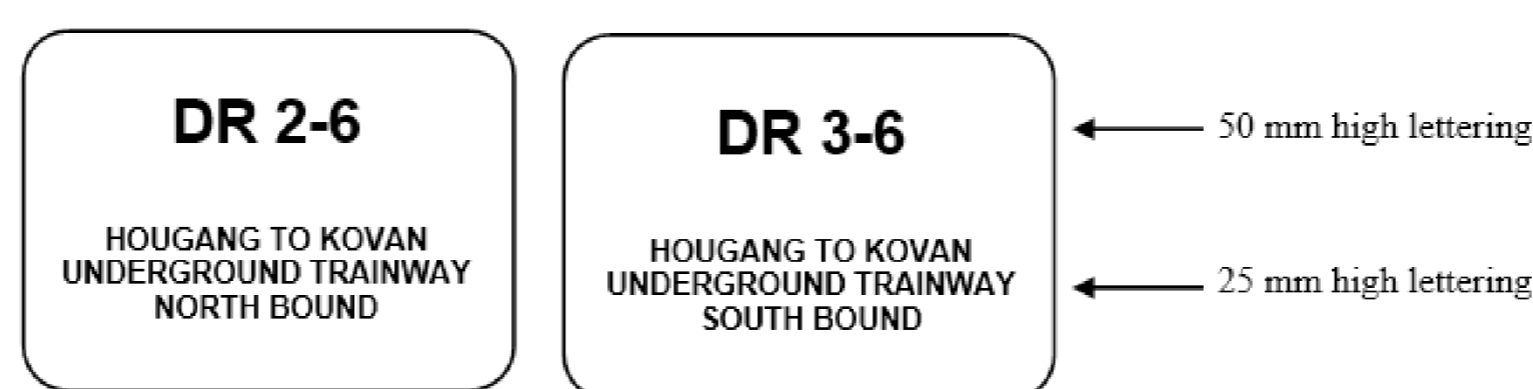

[Diagram 9.3.9a\(8\): Numbering and Labelling of Breaching Inlets for Underground or Enclosed Trainway Dry Rising Mains](#)

(9) Standby fire hoses

Two standby fire hoses shall be provided at each of the following locations:

- (a) Buffer area within 3m from the stair leading to the trainways. See [Diagram 9.3.9a\(9\)\(a\)](#);
- (b) Mid-tunnel exit staircase; and
- (c) Underground or enclosed trainway portal. See [Diagram 9.3.9a\(9\)\(c\)](#).

Standby fire hoses shall be provided in accordance with [Cl.6.2.4](#) with the exception of [Cl.6.2.4b](#).

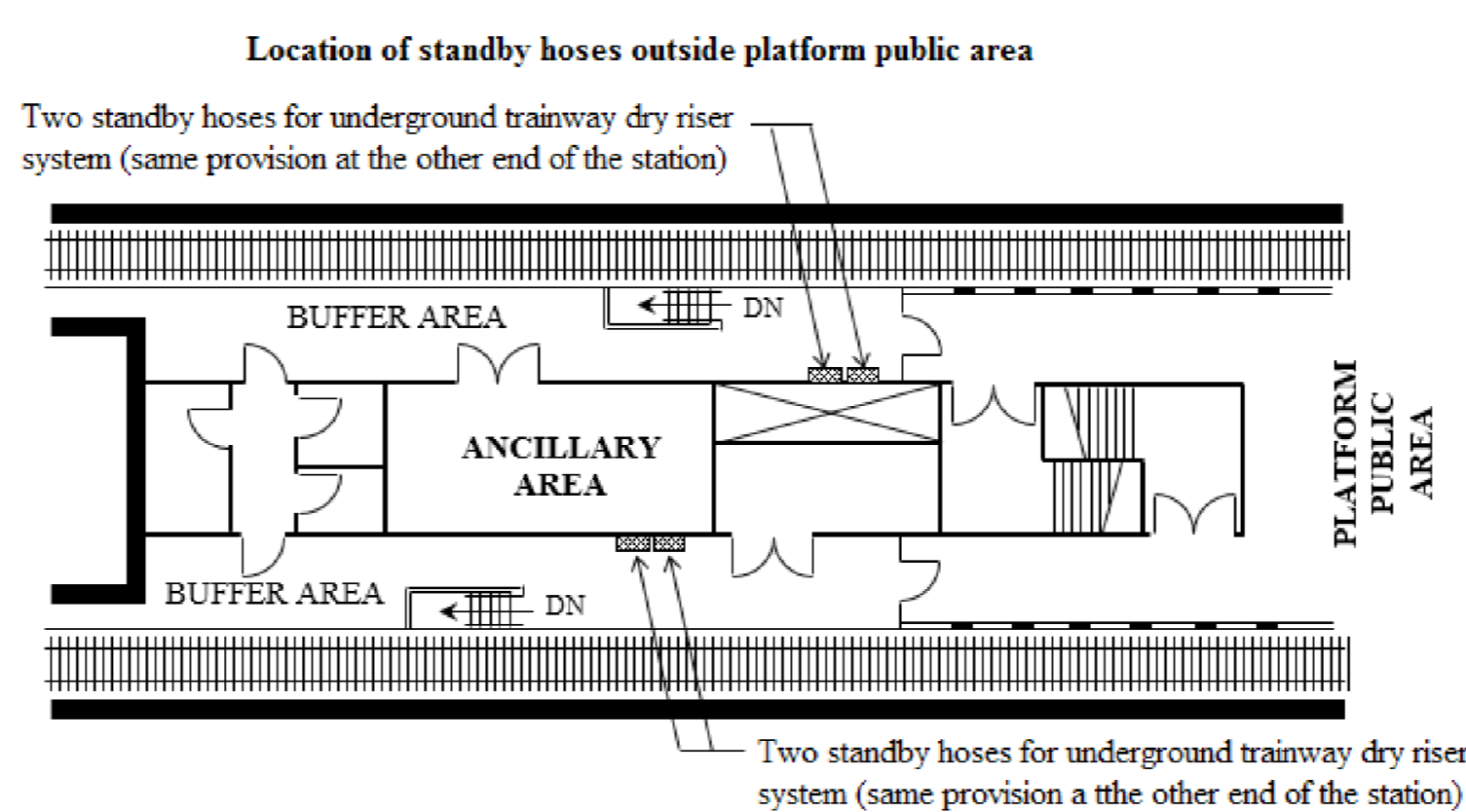

[Diagram 9.3.9a\(9\)\(a\): Location of Standby Hoses Outside Platform Public Area](#)

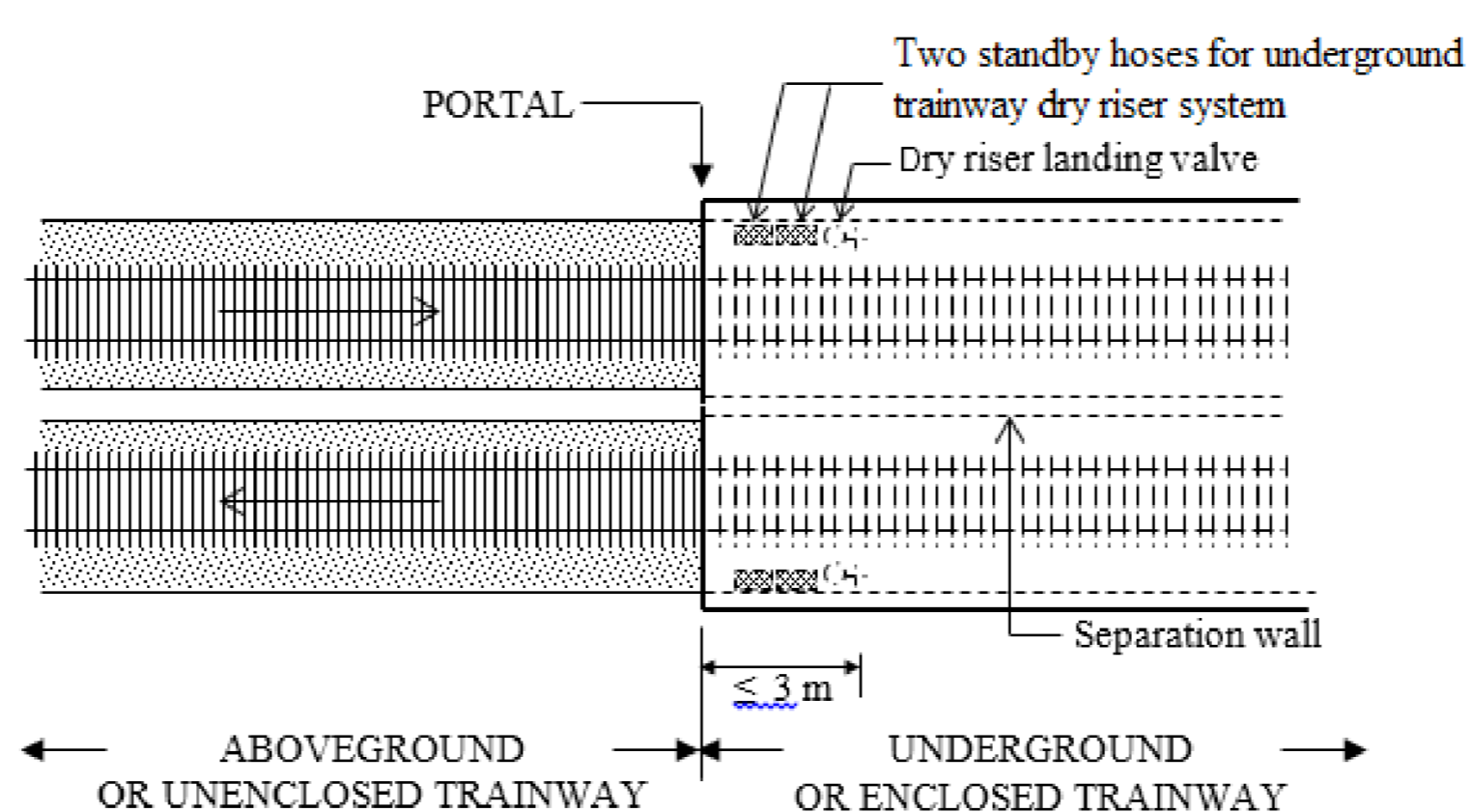

[Diagram 9.3.9a\(9\)\(c\): Location of Standby Hoses at Underground or Enclosed Trainway Portal](#)

b. Automatic fire detection systems

Automatic fire detection systems shall be provided at designated locations in underground or enclosed trainways where trains are stabled during non-revenue hours. The guidance for selection of detectors is described in SS 645. The use of line type heat detectors is permissible.

9.3.10 Communication

a. Provision

Underground or enclosed trainways shall be provided with radio communication facilities capable of operating in the frequency band as allocated and approved by the authority having jurisdiction.

b. Fire resistant cables

Fire resistant cables complying with SS 299 shall be used for communication system equipment, except for the leaky co-axial (LCX) cables which are required to be fire retardant.

9.3.11 Emergency ventilation system

a. Provision

A mechanical emergency ventilation shall be provided in underground or enclosed trainways exceeding 300m.

b. Exemption

A mechanical emergency ventilation system is not required for underground or enclosed trainways at most 60m in length.

c. Engineering analysis

An engineering analysis is required for underground or enclosed trainways more than 60m but less than 300m in length to determine if a mechanical emergency ventilation is required. The analysis shall take into consideration all the factors that affect fire safety. A report of the analysis shall be submitted. If the engineering analysis is not carried out, then a mechanical ventilation system shall be provided.

d. Operation duration

The emergency ventilation system shall make provisions for the protection of people from fire and smoke during a fire in the underground or enclosed trainways and shall be designed to maintain the required air flow rates for at least 2-hrs.

e. System requirements

The emergency ventilation system shall:

- (1) provide a tenable environment along the paths of egress in the incident and non-incident trainways;
- (2) be able to achieve the critical velocity;
- (3) be capable of reaching full operational mode within 120 secs or less; and
- (4) address the maximum number of trains that could be between ventilation shafts during an emergency.

f. Design

The design shall encompass the following:

- (1) The heat release rate from a vehicle and any other combustible materials (if permitted) in the trainways that could contribute to the fire load at the incident site, subject to the approval of the SCDF.
- (2) The rate of fire growth.
- (3) Station and trainway geometries.
- (4) Fans, shafts, and devices for directing air.
- (5) Predetermined procedures for initiating quick response from the OCC during fire.

g. Ventilation fan

The emergency ventilation system fans shall be capable of satisfying the emergency ventilation requirements in either the supply or exhaust mode. Emergency ventilation fan motors shall be designed to achieve their full operating speed in 30 secs or less from a stopped position when started across the line and in 60 secs or less for variable speed motors.

h. Fan rating and standby

Emergency ventilation fans, their motors, and all related components exposed to the exhaust airflow shall be capable of operating in an atmosphere of 250°C for a minimum of 2 hrs. The emergency ventilation fans shall be provided such that in the event one of the fans in the operating system is not operational, the other fan(s) shall be capable of maintaining the system design.

i. Siting of fan starter and control devices

Local fan motor starters and related operating control devices shall be located as far away from the direct air stream of the fans. Thermal overload protective devices shall not be used on motor control of fans used for emergency ventilation.

j. Operation of non-essential fans

Fans not designed to function during fire shall shut down automatically upon activation of an emergency ventilation system unless it can be proven that the emergency air flow is not jeopardised or conflicted with.

k. Cables

Cables used for wiring the fans and the associated controls shall comply with [CI.5.2.2](#).

l. Emergency ventilation system control/ operation

Operation of the emergency ventilation system shall be initiated from the OCC. Local controls located in the PSC of the station, shall be provided and be allowed to control the emergency ventilation system only when the authority is delegated from the OCC to the station PSC.

m. Requirements for system devices

Devices of the emergency ventilation system such as dampers, louvres, silencers, etc., shall be capable of withstanding the repetitive and additive piston effect of moving trains and emergency air velocities. Such devices shall be of non-combustible, fire-resistant materials and be protected, to the greatest extent practical, against fire near the incident area.

n. Vent shafts

Vent shafts that penetrate the surface and that are used for intake and discharge in fire emergencies shall be designed to prevent recirculation of smoke into the station and trainway through air intake openings, station entrances and other surface openings.

9.3.12 Access to underground or enclosed trainway portal

A minimum 1m wide access stair from the ground level to the underground or enclosed trainway portal shall be provided. A gate of minimum 1m width shall be placed as close as possible to the portal to permit easy access to underground or enclosed trainway.

9.3.13 Motorised trolley

a. Provision

Motorised trolley shall be provided at each of the following location:

- (1) Station platform level
- (2) Mid tunnel exit staircase more than 380m from a station
- (3) Trainway portal

b. Construction materials

Motorised trolley shall be constructed of non-combustible material and firmly hanged on wall. Accessories (i.e., batteries, battery chargers, ignition key, handle, and controller) shall be housed in a steel cabinet. Signage complying with SS 508 shall be provided to read "ACCESSORIES FOR MOTORISED TROLLEY". The front part of the cabinet must allow the status of batteries to be easily monitored. The cabinet shall be locked. The key shall be kept in a glass-fronted glazed box alongside the cabinet or as part of the cabinet. Signage complying with SS 508 shall be provided to read "IN CASE OF EMERGENCY, BREAK GLASS FOR KEYS". A spare key shall be kept in the PSC.

c. Accessibility

Motorised trolley provided at station platform level, mid-tunnel exit staircase and trainway portal shall have access to all trainways. Otherwise, separate motorised trolley shall be provided for each trainway.

d. Siting of trolley at platform level

Motorised trolley provided at station platform level shall be within a travel distance of at most 20m to the end platform steps leading to the trackway.

e. Siting of trolley in mid-tunnel exit staircase

Motorised trolley located in mid-tunnel exit staircase shall not impede the means of escape.

f. Trolley batteries

Two sets of batteries (one spare) shall be provided for each trolley. The trolley with maximum load shall be capable of travelling the distance between stations on one set of fully charged batteries.

CLAUSE 9.4 ABOVEGROUND TRAINWAY

9.4.1 Construction materials

a. General

Aboveground trainways shall be constructed of non-combustible materials.

b. Fire resistant rating

The elements of structure for aboveground trainways shall have a fire resistance of at least 2 hours. Test of fire resistance shall be in accordance with [Cl.3.4](#).

c. Cover board

Cover board or any protective material used to provide safety isolation from the contact traction power rail shall have a flame spread rating of not less than Class 1 as specified in [Cl.3.13.3](#) when tested in accordance with BS 476: Part 7.

9.4.2 Setback distance

Setback distance between trainway structure and adjacent building

a. The setback distance between the proposed trainway structure and the adjacent building shall comply with the distance stipulated in [Annex 3B](#) based on the extent of unprotected openings in the external wall of the adjacent building, using the outermost edge of the proposed trainway structure as the relevant boundary, or at least 6m clear of the outermost edge of the proposed trainway structure, whichever is greater. See [Diagram 9.4.2a.](#)

b. For proposed trainway located outside the development boundary of a private development, the distance between the adjacent building(s) and the outermost edge of the proposed trainway shall be at least 6m. See [Diagram 9.4.2b.](#)

c. Measurement of setback distance

The setback distance shall be measured from the edge of trainways to the external wall of the adjacent buildings.

d. Enclosing rectangle

The height of the enclosing rectangle used in the calculations shall be measured up to the height of the trainways.

9.4.3 Emergency access

a. General

Emergency access to the trainways shall be provided.

b. Access to trainway

Access to trainway shall be from the station or via the firefighters' mobile ladder or equipment from roadway adjacent to the trainways. If no adjacent or crossing roadway exist, access roads at a maximum 800m intervals shall be required. The design of the fire engine access road shall be similar to that of the fire engine accessway stipulated in [Chapter 4](#).

c. Security fences for trainways

Where security fences are used to secure an area along the trainways, access gates of at least 1m wide shall be provided. Information that clearly identifies the route and location of each gate shall be provided on the gates or adjacent thereto.

9.4.4 Egress for passengers

a. General

The RTS shall incorporate means for passengers to evacuate a train at any point along the trainways and reach a point of safety. System egress points shall be illuminated.

b. Emergency pathway

An emergency pathway of minimum 800mm width shall be provided along the trainways. Unobstructed access, such as steps or ramp, shall be provided at cross-over trackway

c. Trainway concreted track bed

Where the trainway concreted track bed serves as emergency egress pathway, it shall be nominally level and free of obstructions. Where signalling equipment is located along the emergency egress pathway, ramp and platform shall be provided. The edges of the ramp and platform shall be painted with bright yellow paint to enhance its visibility

CLAUSE 9.5 DEPOT

9.5.1 General

Requirements stipulated in the previous sections of this Code for transit stations and trainways are not applicable to the depot. The depot shall comply fully with the requirements of the Code of Practice for Fire Precautions in Buildings except as herein modified.

9.5.2 Hose reel and areas with traction power

Areas with traction power shall not be covered/ protected by hose reels. A 6m wide zone on plan, enveloping the unenclosed area with traction power need not be fully covered/ protected by hose reels. See [Diagram 9.5.2](#).

Rationale

The purpose is to prevent electrocution when water discharging from the hose reel comes into direct contact with electrical apparatus in the unenclosed areas with traction power that are connected to high voltage electrical power. The 6m wide zone (with 0-100% hose reel protection) is not applicable if the area with traction power is physically separated from the adjacent area by imperforated walls.

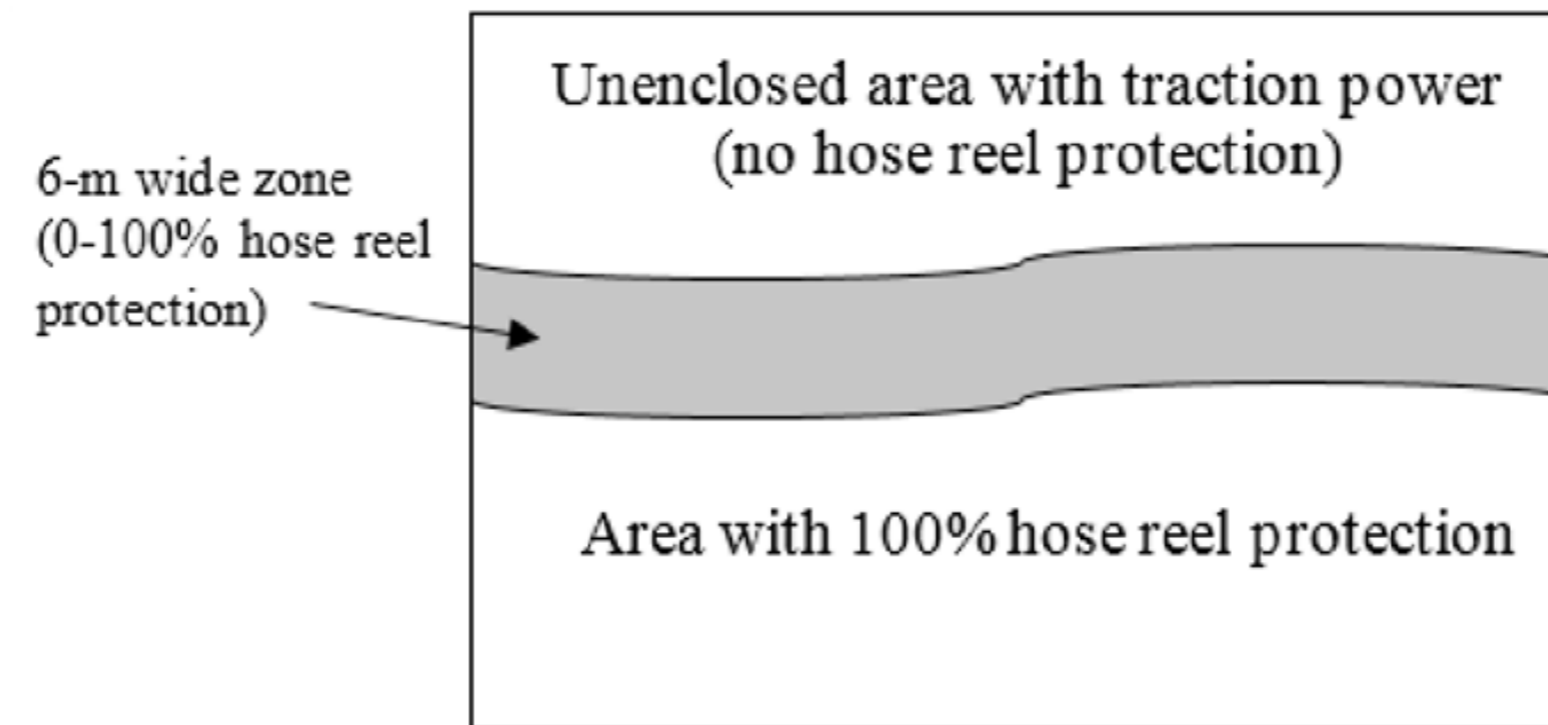

Diagram 9.5.2: Hose Reels and Areas with Traction Power

9.5.3 Stores containing materials that react explosively with water

Hose reels and sprinklers shall not be provided in stores (e.g., thermit and volatile stores) containing materials that react explosively with water.

9.5.4 Purpose group

The depot shall be considered as a factory (Purpose Group VI).

9.5.5 Fire separation from non-transit occupancies

Elements of structure forming the fire separation between track areas/ sidings of the depot and non-transit occupancies shall have at least 4 hrs fire resistance. See [Diagram 9.5.5](#).

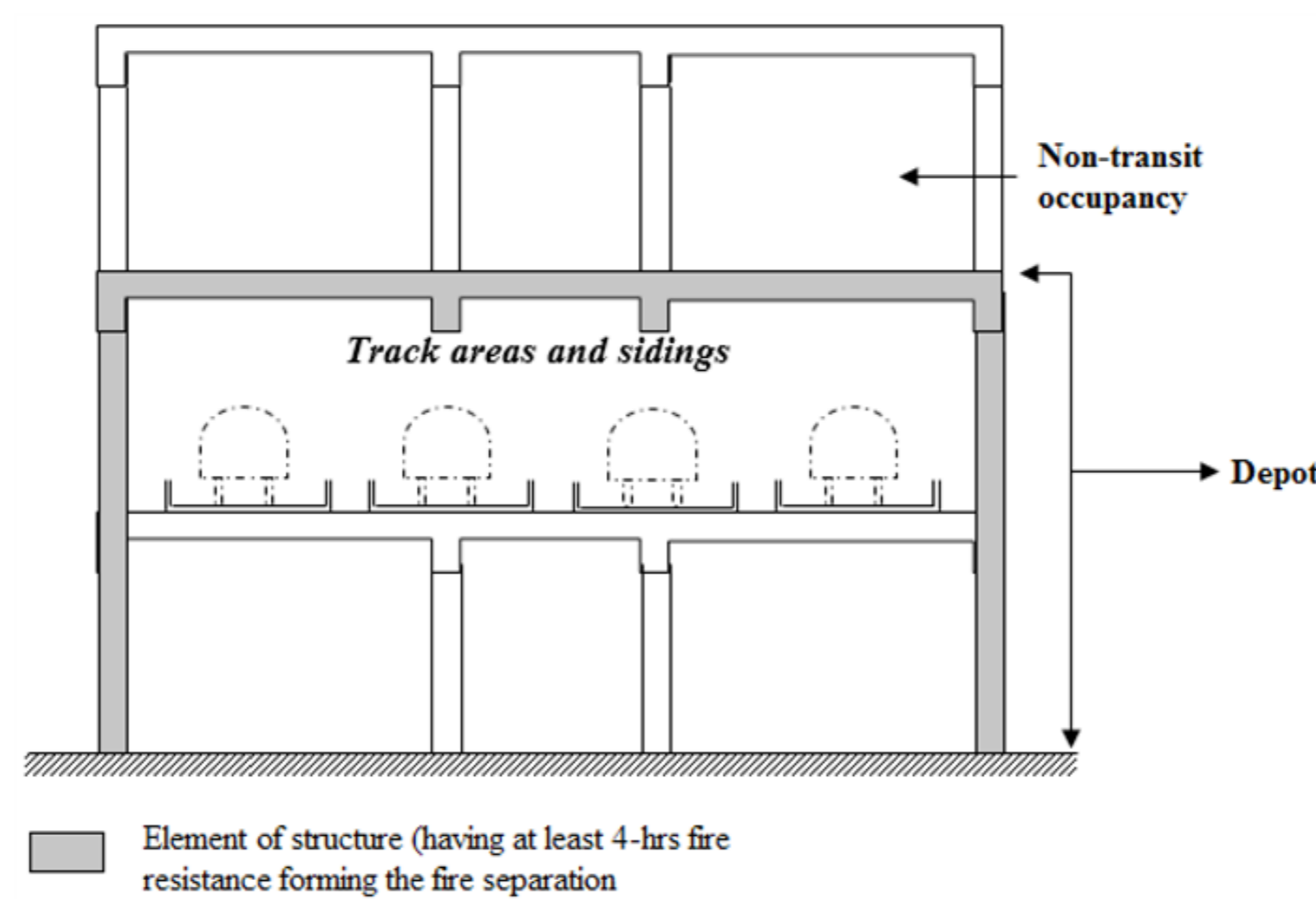

Diagram 9.5.5: Element of Structure Forming Fire Separation Between Depot and Non-Transit Occupancies Shall Have 4-hrs Fire Resistance Rating

9.5.6 Fire resistance of elements of structure

The fire resistance of elements of structure around underground track areas/ sidings shall be at least 4-hrs.

9.5.7 Occupant loads

Rationale

The occupant load is not based on the conventional OL factor because these spaces are only accessed by maintenance personnel and are established by the railway operators. Where such information is not available, QP shall consult the client on the actual number of occupants occupying the areas.

The occupant loads for the track areas and sidings shall be determined based on the expected number of people occupying the areas.

9.5.8 Travel distances

The maximum travel distance for the track areas, sidings and workshop areas for the trains shall be as shown in [Table 9.5.8](#).

TABLE 9.5.8. - MAXIMUM TRAVEL DISTANCE FOR TRACK, SIDING & WORKSHOP AREAS

Type	Sprinkler-protected	Non-sprinkler-protected
One-way	30m	15m
Two-way	120m	90m
Dead-end	15m	15m

Note:

The maximum two-way travel distance for the siding shall be at most 150m if exits are provided at both ends of the siding and that the siding is sprinkler-protected.

9.5.9 Fire safety report

Fire safety report shall be prepared in accordance with the relevant chapter of the Fire Code and submitted.

9.5.10 Detectors for engineered smoke control systems

In lieu of smoke detectors, linear heat detectors of the optic fibre type can be used to activate the engineered smoke control systems in non-public areas.

9.5.11 Automatic fire alarm system

The automatic fire alarm system shall be connected to the OCC.

Rationale

Depot development consisting of more than one building is managed by a single railway operator in term of depot control and monitoring, and emergency operation. Where there are multiple railway operators within the same depot development, the fire emergency operation will still be managed by a single lead operator.

All the alarm panels, control and monitoring devices of other fire safety systems like engineered smoke control system and lift supervisory (if any) from respective buildings will be consolidated and installed into this single FCC for SCDF's control and assessment of the fire situation & firefighting deployment in the depot development.

In view of the above arrangement, a single FCC is sufficient to support firefighting operations.

There shall be one FCC to be provided at the depot development, which can consist of more than one building subject to the following:

- a. It shall be located at the main building nearest to the front entrance of the depot development, which is part of the ingress of the fire engine accessways/ fire engine access roads;
- b. In the case of multiple railway operators within the same depot development, the fire emergency operation shall be managed by a single lead operator; and
- c. All the fire alarm panels, control, and monitoring devices of other fire safety systems e.g. engineered smoke control system, emergency voice communication system, and lift supervisory (if any) from respective buildings shall be housed inside this single FCC.

9.5.13 Two-way emergency voice communication system

a. Provision

For depot with basement storey(s), two-way emergency voice communication system complying with SS 546 shall be provided to the basement storey(s), except for requirements on locations of remote handsets as modified herein.

b. Locations of handsets

The master handset of the two-way emergency voice communication system shall be located near the main alarm panel. Remote handsets shall be provided at the following locations if present at the basement storey(s):

- (1) Fire lift lobbies
- (2) Fire pump room
- (3) Rooms housing smoke control equipment
- (4) Lift motor rooms
- (5) Fire lifts

Rationale

The remote handsets of the communication system shall be provided in the control rooms housing these electrical control equipment and located at or near the fan control panels to facilitate communication & control of the smoke control equipment.

9.5.14 Radio communication

Basement storey(s) of depot shall be provided with radio communication facilities capable of operating in the frequency band as allocated and approved by authority having jurisdiction.

9.5.15 Design fire size and perimeter

Rationale

The design train fire size is an important parameter as it is used for design of engineered smoke control system and tunnel ventilation system.

Where required to be provided with engineered smoke control system, the design train fire size and perimeter shall be substantiated, subject to the approval of the SCDF.

CLAUSE 9.6 OPERATION CONTROL CENTRE

9.6.1 Operation control centre (OCC)

a. Fire separation

The OCC shall have a fire separation of at least 2 hrs from other areas. It shall be provided with dedicated access/ exit from/ to the external via enclosures having a fire resistance of at least 2 hrs.

Note: The protected enclosure is not necessary if the access/ exit is direct from/ to the external.

b. Power supply

Equipment of OCC essential for the operation of trains and the tunnel ventilation system shall be provided with secondary power supply.

c. Ventilation

The OCC shall have the same ventilation requirements as the FCC.

d. Hotline

A hotline shall be provided between the OCC and SCDF Operations Centre.

e. Standby OCC

The above requirements of OCC shall apply to the standby OCC, where provided.

Rationale

A standby OCC serves as a back-up should the main OCC cannot be used.

CLAUSE 9.7 RAPID TRANSIT SYSTEM FACILITY BUILDINGS

9.7.1 Facility buildings

a. Requirements for facility buildings

RTS facility buildings such as on-line electric sub-station, OCC, relay building, and other electrical and mechanical installations shall comply fully with the Code of Practice for Fire Precautions in Buildings, except as herein modified.

b. Facility buildings attached to trainways:

- (1) Where facility buildings located under the above ground trainways, adjacent building within 6m of the outer edges of the aboveground trainway shall be at least 2-hrs compartmented, and.
- (2) Automatic fire alarm system shall be provided in accordance with SS 645. The fire alarm system shall be connected to the OCC.
- (3) Electrical transformer room in facility buildings can be located underground according to Cl.9.8.
- (4) Where cable chambers and service ducts/ spaces have a headroom less than 2m, its means of escape shall be designed in accordance with Cl.2.2.4e., and Cl.8.1.7f. of this Code.
- (5) Fire protection provisions shall comply with Cl.6.1.2a., Cl.6.2.2b.(2), Cl.6.2.5a., Cl.6.3.1b.(1), Cl.6.3.1b.(3), Cl.6.3.3e., Cl.6.4.1d, Cl.6.4.2c, Cl.6.4.4c. and Table 6.4A of this Code.
- (6) Fresh/ exhaust air of the facility buildings can be taken from/ discharged to the intake/ exhaust air shaft in accordance with Cl.7.1.16 of this Code.
- (7) Dual electric feeder power supply in accordance with Cl.5.2.6 of this Code is deemed to have been provided with primary and secondary source of power supplies.

Rationale

This provision allows for early intervention by firefighters in the event of fire occurring in RTS facility buildings.

CLAUSE 9.8 ELECTRICAL TRANSFORMER ROOM IN UNDERGROUND STRUCTURES

9.8.1 General

This set of fire safety requirements is applicable to electrical distribution transformer room located within underground RTS structures. (i.e., stations and facility buildings)

9.8.2 General requirements

a. Compartment size and depth limits

(1) The AFA of transformer room shall not exceed 100m².

(2) The transformer room at station and facility building shall be located not lower than lowest platform level and lowest track level respectively.

b. The transformer oil shall be tested to ASTM D92 or ISO 2592 standard and with the fire point exceeding 300°C

Explanation and Illustrations

For station with stacked platforms configuration, the platform level in this clause shall mean the lowest platform level.

c. The underground structure housing the transformer shall not be sited within 15m of an exit staircase shaft.

Rationale

The travel distance between the exit access door or transformer at exit staircase shaft is intended to prevent possible fire at transformer from affecting the exit staircase.

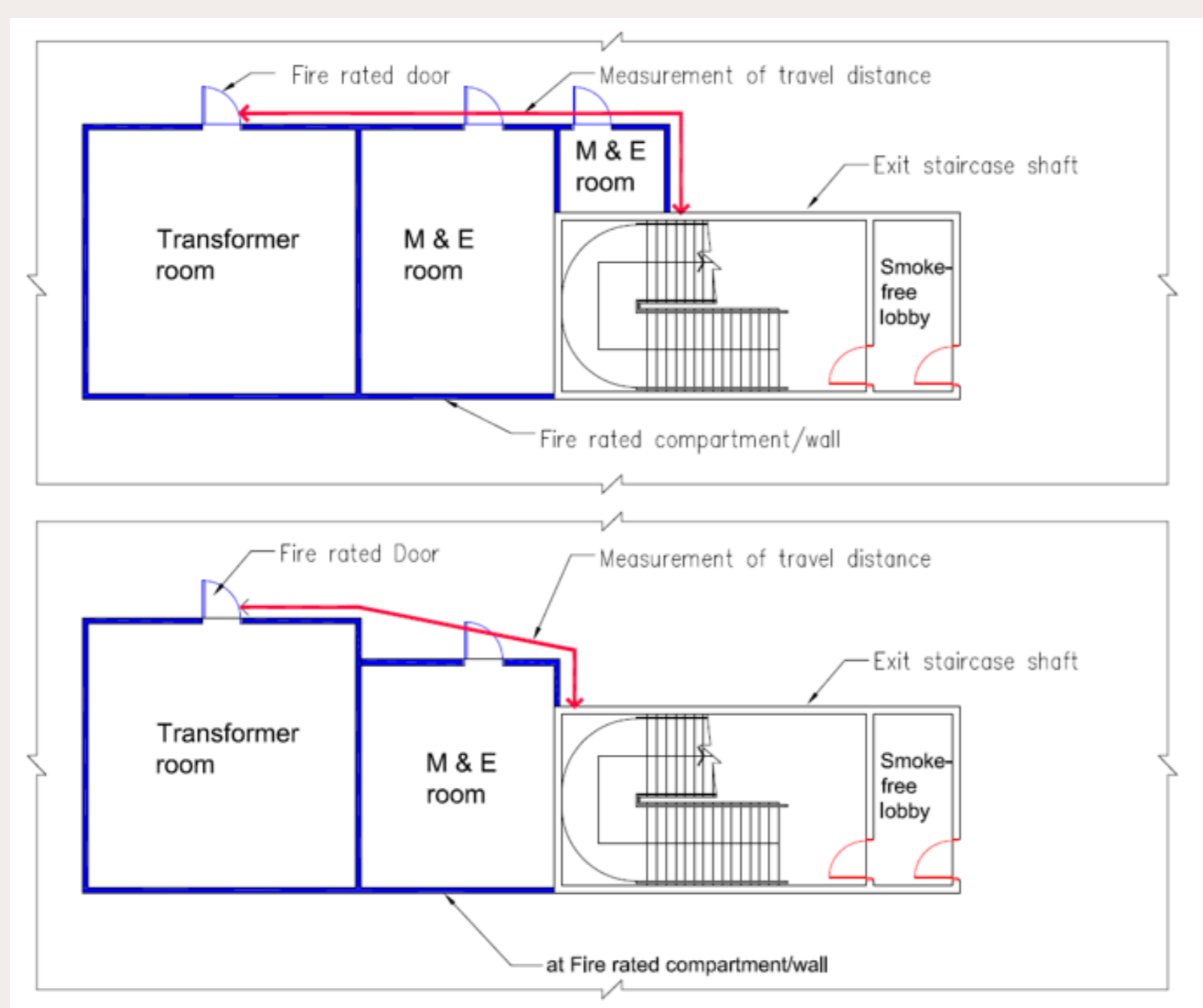

d. Provision to contain spillage of transformer insulating liquid shall be provided.

e. Firefighting systems

(1) Automatic fire alarm system

(a) An automatic fire alarm system shall be provided for the electrical transformer room.

(b) The fire alarm system for the underground transformer room shall be a dedicated zone, linked to the building fire alarm system. A summary fire alarm status (alarm/ fault) shall be provided to the main fire alarm panel in the building development.

(2) Fire suppression system

Automatic fire suppression system such as automatic sprinklers, foam-water sprinklers or water mist shall be provided for the electrical transformer room.

Diagram 9.4.2a.: Separation Distance

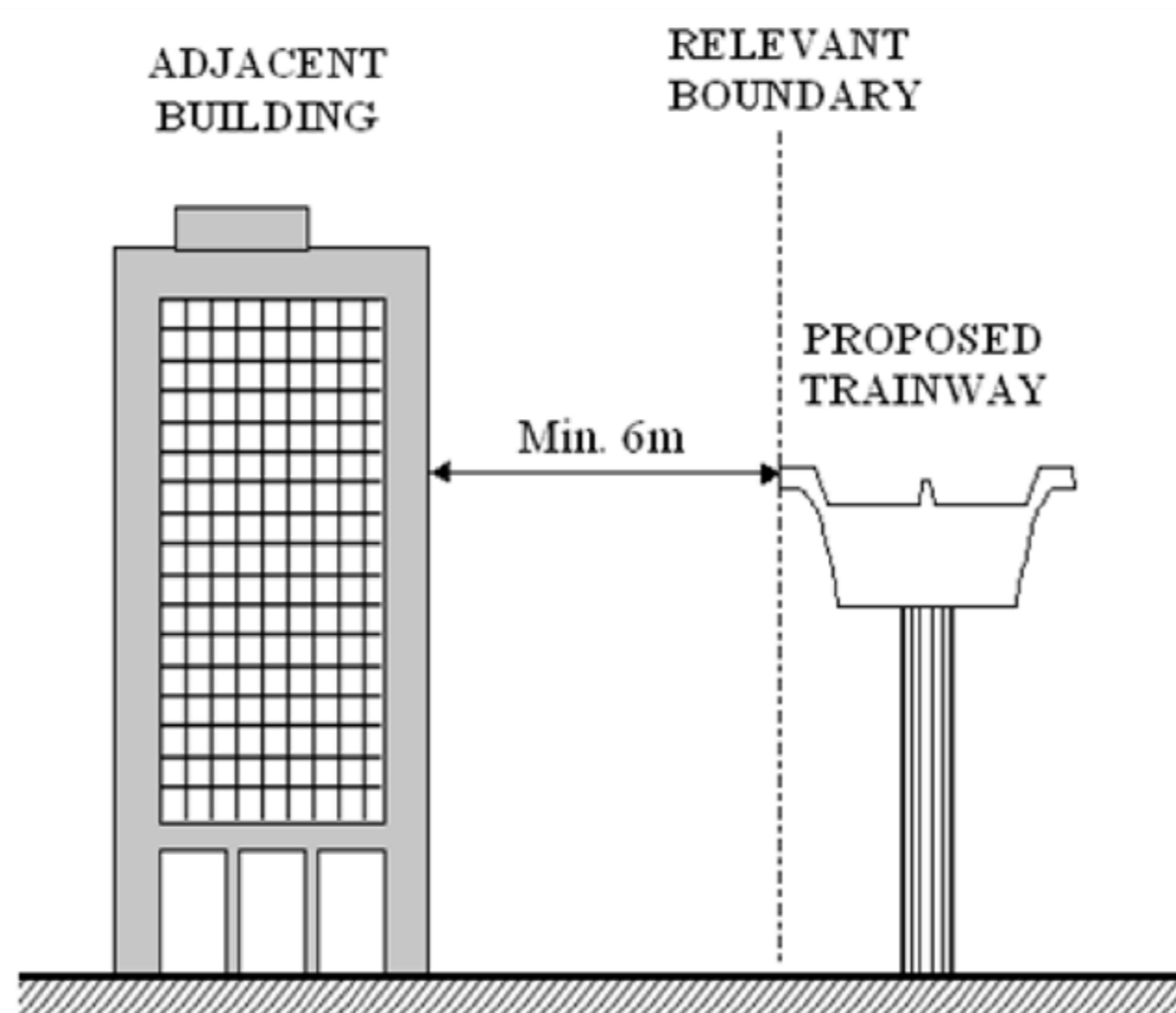

Diagram 9.4.2a.: Separation Distance

Diagram 9.4.2b.: Separation Distance – Proposed Trainway Outside Development Boundary

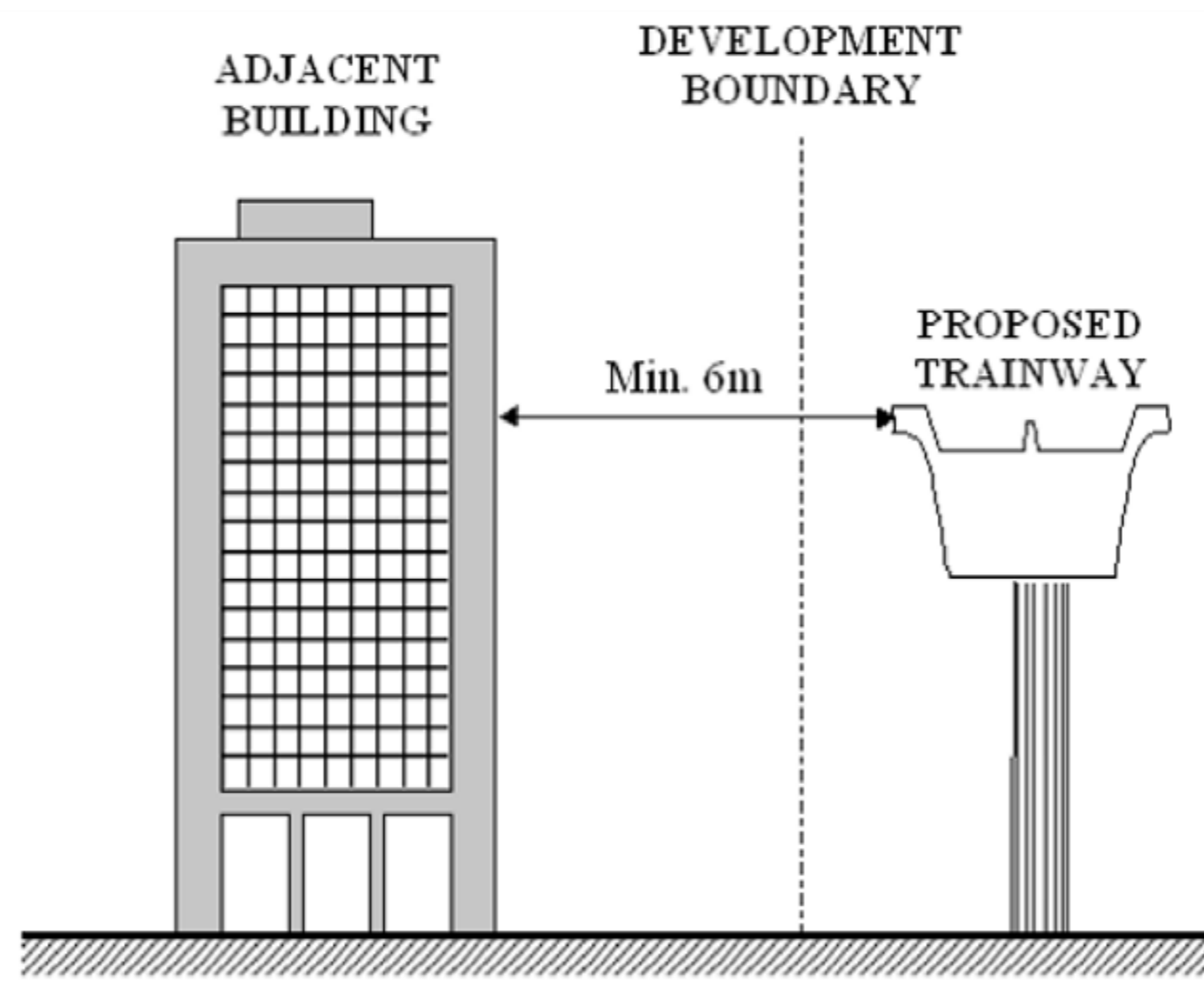

Diagram 9.4.2b: Separation Distance – Proposed Trainway Outside Development Boundary

Clause No.	Amendment Date	Effective Date	Clause Status	Clause Before Amendment	Circular Date
------------	----------------	----------------	---------------	-------------------------	---------------

CLAUSE 1.0 GENERAL

1.0 GENERAL

a. Fire Safety Report is to document the provision of fire protection, life safety features and fire safety management in the station. This report serves as a useful reference to Fire Safety Managers (FSMs), station/ transit operator, Registered Inspectors (RIs), the SCDF and Qualified Persons (QPs) who carry out any subsequent additions and alteration works. Where the nature of the additions and alteration works would require the updating of the Fire Safety Report, the QP shall be responsible to submit revised and updated report to the station/ transit operator and the SCDF.

b. The project QP shall submit the fire safety report when making building plan submission for projects such as:

- (1) Station exceeding 24m in habitable height or underground station exceeding 9m below grade level.
- (2) Station with Accessible Floor Area (AFA) greater than 5000m² or having a total occupant load exceeding 1000 persons.
- (3) Stations exceeding 24m in habitable height where fire-rated drywalls are used for the construction of protected shafts for staircases and/or lifts.
- (4) Stations exceeding one storey using fire-rated board protection or intumescent paints for structural steel.
- (5) Stations with structural steel members coated with intumescent paint (for station of habitable height below 24m, only item a., b., d., e. & q. of paragraph 2 need to be included in the fire safety report).

c. In stations, where there may be presence of corrosive atmosphere that may affect the effectiveness of intumescent paints for protection to structural steel members of stations and fire-rated dry board, such proposal shall be subjected to evaluation of the SCDF.

CLAUSE 2.0 CONTENTS OF THE REPORT

2.0 CONTENTS OF THE REPORT

The write-up of the report on fire protection and life safety features shall include the following subjects. However, qualified person could expand or modify the report to suit his presentation:

- a. project description;
- b. fire safety design concept;
- c. fire engine accessibility;
- d. means of escape;
- e. structural fire precautions;
- f. control and exhaust of smoke and toxic fumes;
- g. firefighting systems;
- h. fire alarm system;
- i. emergency power supply;
- j. emergency evacuation lighting;
- k. emergency voice communication system;
- l. two-way emergency voice communication system;
- m. emergency lift control;
- n. areas of fire risk;
- o. fire scenario;
- p. conclusion; and
- q. attachments.

CLAUSE 3.0 BRIEF EXPLANATORY NOTE FOR OUTLINE REPORT ON FIRE PROTECTION AND LIFE SAFETY FEATURES

3.0 BRIEF EXPLANATORY NOTE FOR OUTLINE REPORT ON FIRE PROTECTION AND LIFE SAFETY FEATURES

a. Project description

A description of the project with brief outline of the facilities provided.

b. Fire safety design concept

This would include the safety design concept incorporated in the project such as the application of design and provision of areas of refuge, smoke barriers, additional compartment walls/ doors in sectionalizing the large atrium floors etc. and other added fire safety features provided over and above the intent of the Code.

c. Fire engine accessibility

This would briefly outline the driveways, which are paved to withstand the load of fire engines, to be provided.

d. Means of escape

This would include the description of the escape routes that would be taken by occupants in the station in a fire scenario, besides the provision of the number, type and location of staircases, etc.

e. Structural fire precautions

This would outline the fire resistance rating and the type of structural protection to elements of structures, compartment walls/ floors, types and methods of fire-stoppings to ducts, cavity and curtain walling construction, and types and rating of all fire doors.

f. Control and exhaust of smoke and toxic fumes

This would include the description of the type of system to be provided to atrium, staircases and lobbies, air-conditioning units, etc.

g. Firefighting system

This would include the active protection system such as portable fire extinguishers, hose reels, dry rising mains, sprinkler system, gas flooding system, fixed/ portable water monitors, fixed water spray, drenchers, etc.

h. Fire alarm system

This would include the provision of passive fire protection system such as automatic fire detection systems (smoke or heat type), "break the glass" fire alarm system. Besides naming the type of automatic system, the description shall also include where the detectors would be generally located in fire risk areas/rooms such as lift motor rooms, electrical switch rooms, MDF, IDF and PABX rooms electrical ducts and enclosed elevator shafts, and how, when any of the systems is activated, the public, the people in the PSC, OCC or FCC are alerted.

i. Emergency power supply

This would include the description of how the emergency power system operates in times of loss of normal electric power supply to any part of the station and the areas or systems that will be designed to receive emergency power.

j. Emergency evacuation lighting

This would include the description of the system designed in accordance with SS 563, and the location of exit signs etc. and the types of battery system, and designed time for the switchover to emergency lighting system from the time the normal power supply is cut-off.

k. Emergency voice communication system

This would involve the description of the provision of the one-way zoned and electrically monitored emergency paging system to as stated in *Cl.8.2.2*. The emergency public address system which generally complies with SS 546 would include communication between OCC, PSC or FCC and all parts of the station except lift cars through electrical loudspeakers.

l. Two-way emergency voice communication system

This would describe the operation of the 2-way zoned and coded voice communication system, which is electrically supervised from the central control located in the FCC or in the absence of which, the main alarm panel, including the provision of slave telephones to critical areas as state in *Cl.8.2.7*.

m. Emergency lift control

This would describe the function of the Emergency Lift Control conforming to the requirements under SS 550. The description of the emergency lift control would also include the sequence of events in case of:

- (1) power failure;
- (2) fire emergency; and
- (3) both power failure and fire emergency.

n. Areas of fire risk

This would briefly describe the areas of fire risk such as AC plant room, generator room, oil tank room, etc. and the type of fire protection/ detection system proposed.

o. Fire scenario

Under this subject, the qualified person would have to assume the outbreak of a fire in one of the critical floors or areas and describe the sequence of operation of the fire protection and life safety design features.

p. Conclusion

This would include the summing up of the outline concepts and systems that have been designed for the project.

q. Attachments

- (1) Location plans of steel structural members coated with intumescent paint.
- (2) Location plans of fire risk areas.
- (3) Any other attachments required for the report.

Clause No.	Amendment Date	Effective Date	Clause Status	Clause Before Amendment	Circular Date
------------	----------------	----------------	---------------	-------------------------	---------------

CLAUSE 1.0 GENERAL

Clause 1.0 General

The Fire Safety Instruction Manual is a document prepared by the project QP to remind the station owner, transit operator, tenant, and/ or contractor on the management of fire safety provisions for the station. This includes maintenance regimes, evacuation procedures, and other relevant documents to be kept and maintained by the relevant parties. Any subsequent additions and alteration works shall be updated in the Fire Safety Instruction Manual by the QP carrying out the A/ A works.

The Fire Safety Instruction Manual, including any subsequent updates, shall be submitted by the project QP to the SCDF for record when making building plan submission. A copy of which shall be handed officially to the relevant parties for information and safe keeping before occupation of the building.

The QP can expand or modify the Fire Safety Instruction Manual to suit his presentation so as to convey the fire safety intents/ requirements to the relevant parties.

CLAUSE 2.0 SCOPE

Clause 2.0 Scope

The QP shall prepare a Fire Safety Instruction Manual if the project involves any of the following:

- a. Fire safety provisions for PWDs
- b. Stations using intumescent paint
- c. Liquefied Petroleum Gas (LPG) cylinder installation
- d. Use of lifts in stations for evacuation
- e. Hoarding & safety nets
- f. Mega underground developments
- g. Kitchen exhaust ducts
- h. Fire-rated dry construction

CLAUSE 3.0 CONTENTS OF THE MANUAL

Clause 3.0 Contents of the Manual

The Fire Safety Instruction Manual shall include the following subjects:

- a. project description;
- b. list of items under paragraph 2 present in this project; and
- c. relevant information for each applicable item.

CLAUSE 4.0 RELEVANT INFORMATION TO BE INCLUDED IN THE FIRE SAFETY INSTRUCTION MANUAL

4.1 Fire safety provision for PWDs

a. Planning of evacuation for PWDs

The transit operator shall pre-plan the evacuation procedures for PWDs. Planning includes identifying the needs of PWDs and making arrangements for assistance during emergency. Proper procedures and effective practices will ensure the safety of PWD in the event of fire emergency.

b. The evacuation procedures shall be tested at least once a year and involve both horizontal, if provided, and vertical evacuation.

c. Transit operator shall ensure that the staff designated to help PWD in the event of fire emergency are fully trained to execute the following evacuation procedure.

d. In the event of fire emergency:

(1) Trained staff on duty shall check and provide necessary assistance to evacuate PWD.

(2) SCDF takes control of the situation upon their arrival at the scene. Trained staff shall assist SCDF (if required) to evacuate PWD.

4.2 Use of intumescent paints for protection to structural steel members of stations

a. Inspection and maintenance

(1) The transit operator shall carry out annual inspection checks to ensure that the intumescent paint coatings are not damaged or tampered with. Records of inspection shall be properly kept.

(2) For stations with Fire Certification, the annual renewal of the certificate shall include the inspection of the columns and beams coated with intumescent paint. The inspection shall be carried out by a QP.

b. Addition/alteration works

For addition/alteration works in a station where structural steel members are protected by intumescent paint, the following requirements shall be complied with:

(1) The transit operator assisted by the FSM, shall engage a QP who shall submit building plans to the SCDF. The building plans shall be accompanied by the QP's declaration as to whether the existing columns, beams coated with intumescent paint are/will be affected.

(2) Inspection certificate endorsed by a RI shall be required and kept by the transit operator.

c. There shall be no highly flammable/ combustible materials stored within the vicinity of any structural steel members protected by intumescent paint.

4.3 Hoarding & safety nets

a. The station owner/ transit operator shall ensure a copy of QP-endorsed hoarding plans is kept at the FCC, PSC or information counter in the order of priority at all times. Such requirement is optional if the hoarding does not affect the following areas/ facilities:

(1) fire hydrants;

(2) fire engine accessway/fire engine access road;

(3) fire lift;

(4) exit staircase; and

(5) dry riser.

b. The station owner/ transit operator is required to notify all the tenants/ occupants of the locations of alternate means of escape 2 weeks prior to carrying out the hoarding and renovation works.

c. The station owner/ transit operator is required to inform the nearest SCDF fire station of any hoarding works that affect the above-mentioned areas/ facilities.

d. The affected firefighting facilities/ areas shall be clearly shown on the plans and submitted to the relevant fire station. The alternative or nearest firefighting facilities that can be accessed by the fire station responding personnel shall be highlighted on the plan.

4.4 Kitchen exhaust ducts

The station owner/ transit operator/ tenant/ operator shall ensure that the entire kitchen exhaust system, including those within individual restaurant/F&B outlet shall be properly maintained. The entire (interior and exterior) exhaust duct and kitchen hood shall be degreased and cleaned at least once every 12 months. The work shall be carried out by a specialist and the records of cleaning and degreasing shall be kept by the relevant parties for verification.

4.5 Fire-rated dry construction

The station owner/ transit operator shall engage a QP for any subsequent A&A works involving new or existing fire-rated dry construction.

Clause No.	Amendment Date	Effective Date	Clause Status	Clause Before Amendment	Circular Date
------------	----------------	----------------	---------------	-------------------------	---------------