



SCDF

The Life Saving Force

... for a safer Singapore



TECHNICAL REQUIREMENTS FOR STOREY SHELTERS 2021

SINGAPORE CIVIL DEFENCE FORCE



Contents

Chapter 1 - Introduction

- Clause 1.1 General
- Clause 1.2 Peacetime Use
- Clause 1.3 Abbreviations
- Clause 1.4 Definitions

Chapter 2 - Architectural Requirements

- Clause 2.1 SS or NS Form
- Clause 2.2 Size of SS
- Clause 2.3 Wall And Slab Thickness of Thickness Of SS And NS
- Clause 2.4 Location of SS
- Clause 2.5 SS Door
- Clause 2.6 Fixtures in SS
- Clause 2.7 NS in SS Tower
- Clause 2.8 Finishes in SS
- Clause 2.9 Exit Staircase
- Clause 2.10 Door Recess
- Clause 2.11 Design Requirements of SS
- Clause 2.12 Design Requirements Of S/C SS and Scissor S/C SS

Chapter 3 - Structural Requirements

- Clause 3.1 General
- Clause 3.2 Materials
- Clause 3.3 Analysis
- Clause 3.4 Member Dimensions and Reinforcement Requirements
- Clause 3.5 Detailing of SS Tower
- Clause 3.6 Penetration Of Services

Chapter 4 - Ventilation Sleeves

- Clause 4.1 General
- Clause 4.2 Position
- Clause 4.3 Accessibility Of Ventilation Sleeves
- Clause 4.4 Fragmentation Plate

Chapter 5 - SS Door

- Clause 5.1 General
- Clause 5.2 Approved SS Door
- Clause 5.3 Removable Door KERB - Applicable for S/C SS and Scissor S/C SS only
- Clause 5.4 SS Door Notice
- Clause 5.5 Specifications of SS Door Notice

Chapter 6 - Construction and Commissioning

- Clause 6.1 General
- Clause 6.2 Structural Works
- Clause 6.3 SS Door
- Clause 6.4 Peacetime Requirement of Ventilation Sleeves
- Clause 6.5 Commissioning Requirements

Chapter 7 - Permitted And Not Permitted Works in SS Tower

- Clause 7.1 General
- Clause 7.2 Permitted and Not Permitted Works

Chapter 8 - Regulated Shelter Products

- Clause 8.1 General
- Clause 8.2 Definitions
- Clause 8.3 Accreditation and Certification
- Clause 8.4 Serial Labels

CLAUSE 1.1 GENERAL

A storey shelter (SS) is designed and constructed for the protection of people against weapon effects during a war emergency. People should not stay inside there for protection during other peacetime emergency situations such as a fire in a building. The SS is located at a common property area of a storey and serves the residents of the dwelling units of that storey.

CLAUSE 1.2 PEACETIME USE

During peacetime, the SS may be used as a common facility for the residents of the storey. Where the staircase or scissor-staircase doubles up as a SS, it is used as a fire exit staircase. The other statutory requirements governing the design and use of the SS space for the specific peacetime use shall also be complied with.

CLAUSE 1.3 ABBREVIATIONS

Clause	Description	Abbreviations
1.1	Storey Shelter	SS
2.1	Non-Shelter	NS
2.1	Staircase Storey Shelter	S/C SS
2.2.1	Finished Floor Level	FFL
2.2.1	Grass Floor Area	GFA

CLAUSE 1.4 DEFINITIONS

Clause	Description	Abbreviations
2.1	The space in the SS tower that is not intended for use as a shelter.	Non-Shelter
2.1	Building exit staircase used as SS	S/C SS
2.2.2 (a)	Height of SS measured from its FFL to the soffit of the SS ceiling slab.	SS Clear Height
2.2.2 (a)	Height of NS measured from its FFL to the soffit of the NS ceiling slab.	NS Clear Height
2.3.1	Setback to be protected by slab/trellis at ceiling level and distance to be measured horizontally from external face of SS wall.	Setback Distance
2.3.2 (a)	The SS located below the top-most roof level	Top-most SS

Clause No.	Amendment Date	Effective Date	Clause Status	Clause Before Amendment	Circular Date
------------	----------------	----------------	---------------	-------------------------	---------------

CLAUSE 2.1 SS OR NS FORM

The configuration of a SS or Non-Shelter (NS) on plan shall be rectangular or square shape. In the case of a staircase storey shelter (S/C SS) and scissor S/C SS, there can be slight deviations from the rectangular or square shape.

CLAUSE 2.2 SIZE OF SS

2.2.1 Area and Volume

a. The minimum internal floor area and minimum internal volume of a SS or S/C SS shall be based on gross floor area (GFA) of dwelling unit and nominal occupancy of dwelling unit in accordance with TABLE 2.2.1.

Figures & Tables

TABLE 2.2.1: MINIMUM INTERNAL SS FLOOR AREA AND VOLUME

Gross Floor Area (GFA)* of Dwelling Unit	Nominal Occupancy of Dwelling Unit (No. of persons catered for in SS)
$GFA \leq 45m^2$	2
$45^2 < GFA \leq 75m^2$	3
$75m^2 < GFA \leq 140m^2$	4
$GFA > 140m^2$	5

Note:

The GFA of the dwelling unit excludes the area of balconies that are open on at least two sides to make the balconies conducive for sky-rise gardening in accordance with URA guidelines.

$$\text{Area of Storey Shelter} = \text{TNO} \times 0.6m^2$$

$$\text{Volume of Storey Shelter} = \text{TNO} \times 1.8m^3$$

TNO = Total Number Occupancy of units served by Storey Shelter

e. The maximum internal length of any floor and roof slab of a SS shall be 10000mm. The minimum internal width of a SS or S/C SS shall be 1200mm. Refer to FIGURE 2.2.1(a) and 2.2.1(b).

Figures & Tables

FIGURE 2.2.1(a): TYPICAL LAYOUT OF SS

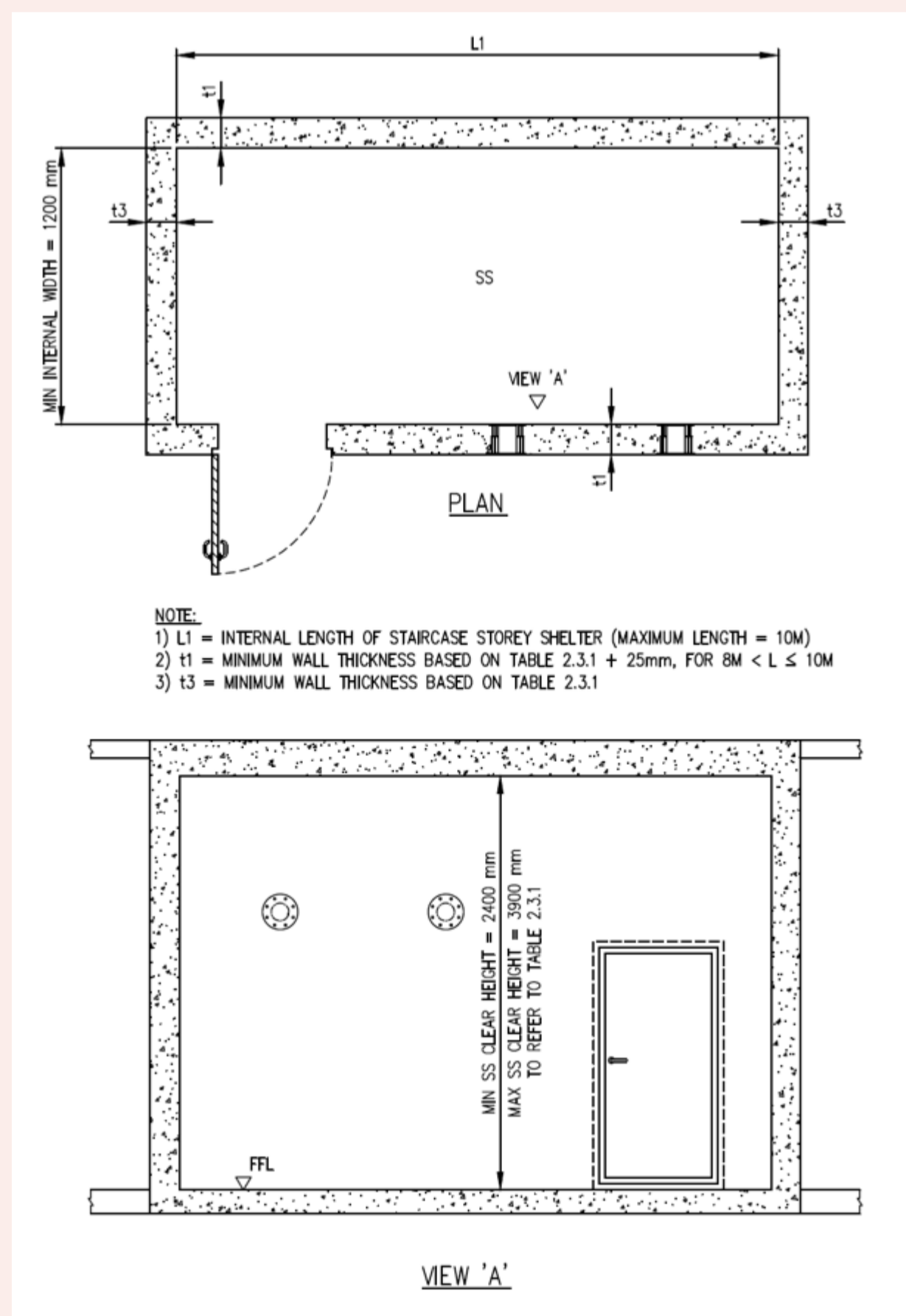
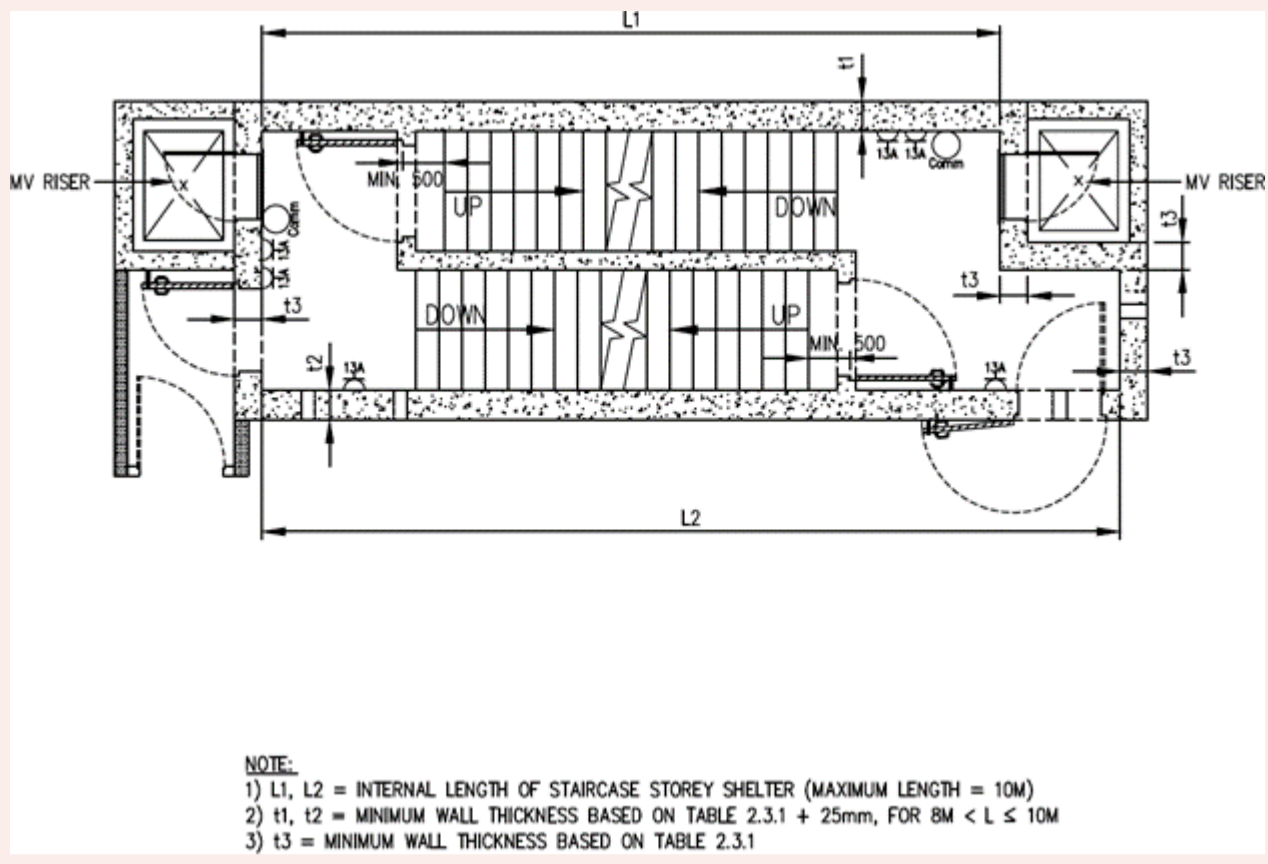

FIGURE 2.2.1(b): TYPICAL LAYOUT OF S/C SS



- f. For S/C SS, the minimum internal width of staircase flight shall be at least 1150mm. See FIGURE 2.12.1(f).
- g. The ratio of the internal length to the internal width shall not exceed 3:1.

Figures & Tables

FIGURE 2.12.1(f): TYPICAL PLAN OF S/C SS COMPARTMENT

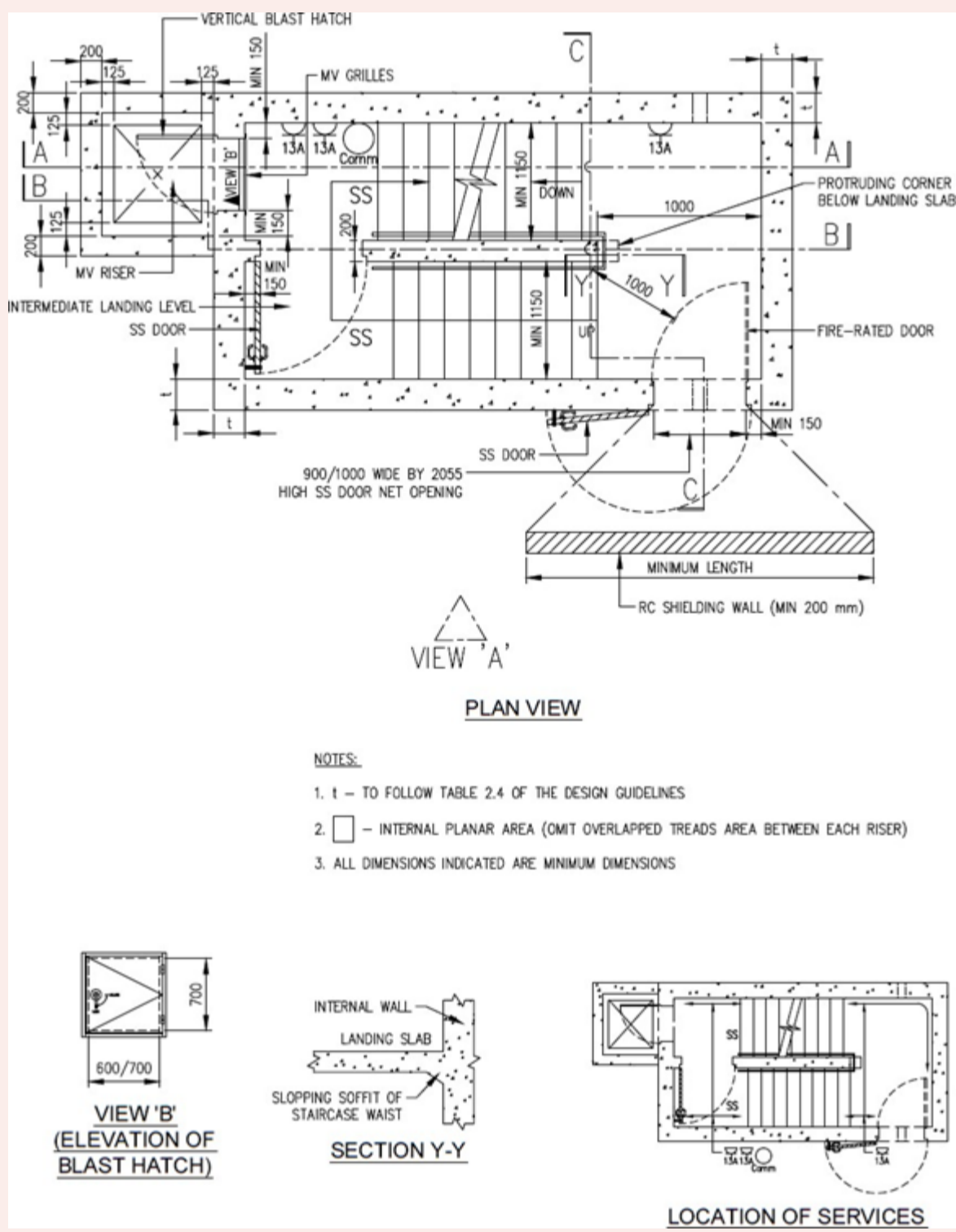

2.2.2 Heights

- a. The minimum SS clear height shall be 2400mm. Refer to FIGURE 2.2.1(a). The minimum NS clear height shall be 2400mm
- b. The minimum S/C SS or scissor S/C SS clear height shall be 2400mm. Within the S/C SS or scissor S/C SS tower, where the storey height deviated from the typical storey height, the minimum clear height of NS in S/C SS or scissor S/C tower shall be 2000mm. Refer to FIGURE 2.2.2(a).

Figures & Tables

FIGURE 2.2.2(a): SECTION OF S/C SS TOWER SHOWING S/C SS AND NS CLEAR HEIGHT

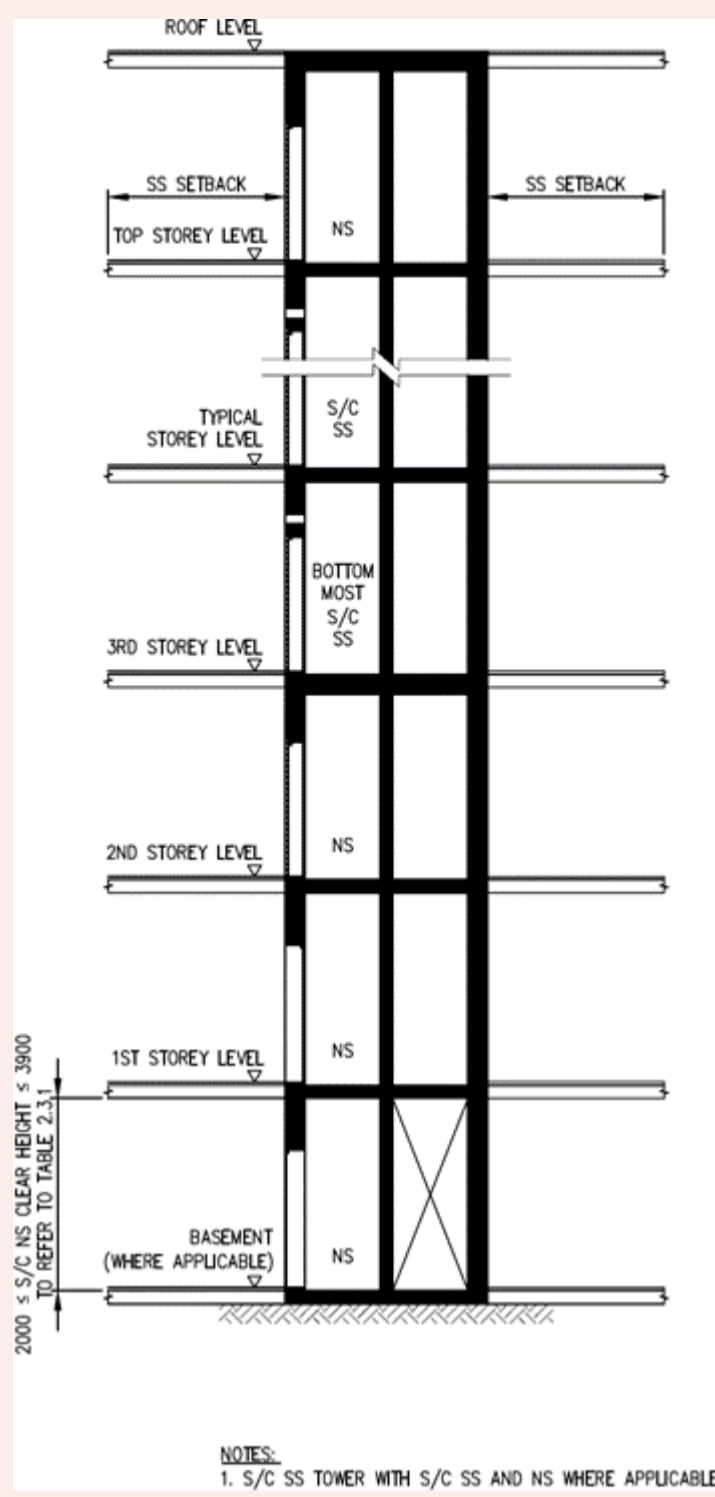

c. The maximum clear height of a SS, S/C SS, scissor S/C SS and NS shall be 3900mm. Refer to FIGURE 2.2.1(a), 2.2.2(a) and TABLE 2.3.1.

Figures & Tables

FIGURE 2.2.1(a): TYPICAL LAYOUT OF SS

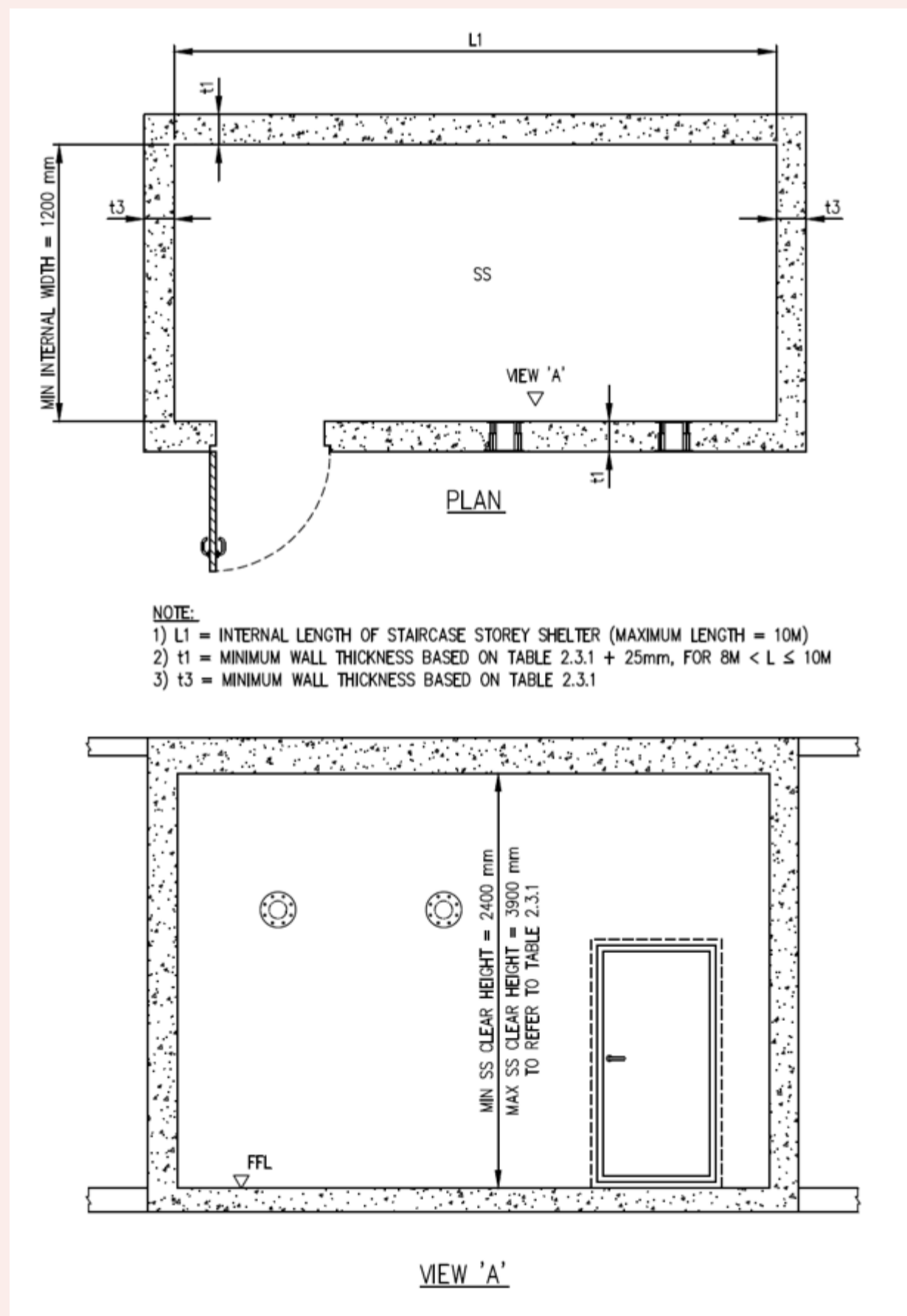
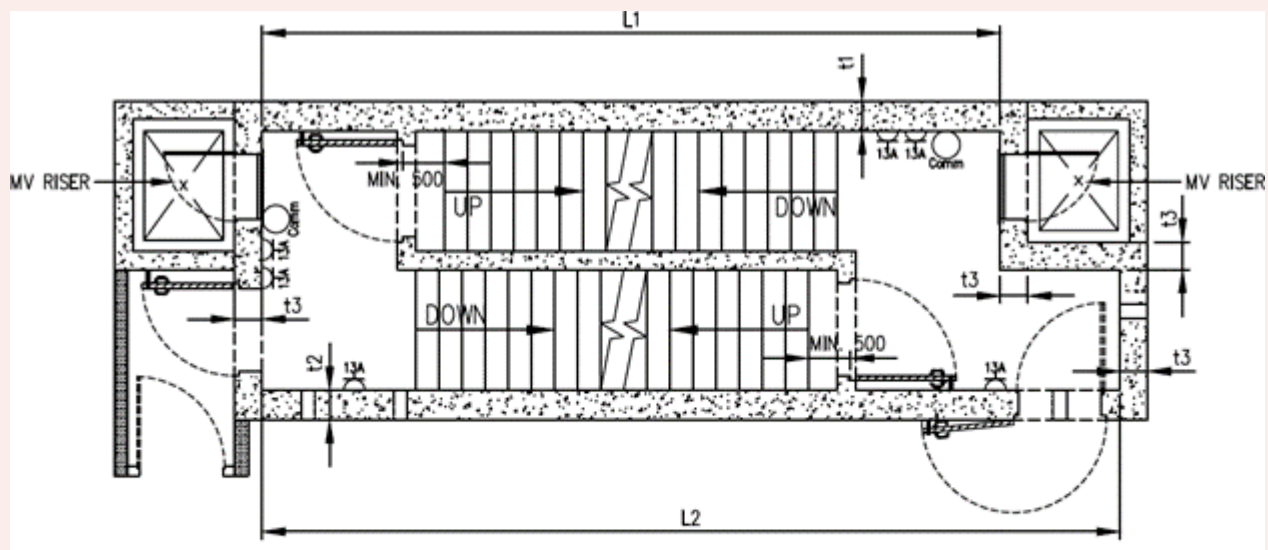

FIGURE 2.2.1(b): TYPICAL LAYOUT OF S/C SS



NOTE:

- 1) L1, L2 = INTERNAL LENGTH OF STAIRCASE STOREY SHELTER (MAXIMUM LENGTH = 10M)
- 2) t1, t2 = MINIMUM WALL THICKNESS BASED ON TABLE 2.3.1 + 25mm, FOR 8M < L ≤ 10M
- 3) t3 = MINIMUM WALL THICKNESS BASED ON TABLE 2.3.1

TABLE 2.3.1 : REQUIRED MINIMUM SS AND NS WALL THICKNESS

Storey Height (SH) (mm)	SS/NS Clear Height (Ht) (mm)	Setback Distance of SS Wall (mm)	Wall Thickness (mm)
SH ≤ 4000	2400 ≤ Ht ≤ 3400	≤ 6000	300
		> 6000	250
	3400 < Ht ≤ 3900	≤ 6000	325
		> 6000	275
4000 < SH ≤ 6000	2400 ≤ Ht ≤ 3400	≤ 7000	300
		> 7000	250
	3400 < Ht ≤ 3900	≤ 7000	325
		> 7000	275
6000 < SH ≤ 8000	2400 ≤ Ht ≤ 3400	≤ 8000	300
		> 8000	250
	3400 < Ht ≤ 3900	≤ 8000	325
		> 8000	275
8000 < SH ≤ 10000	2400 ≤ Ht ≤ 3400	≤ 9000	300
		> 9000	250
	3400 < Ht ≤ 3900	≤ 9000	325
		> 9000	275

CLAUSE 2.3 WALL AND SLAB THICKNESS OF THICKNESS OF SS AND NS

2.3.1 SS Wall Thickness

The thickness of SS wall varies accordingly to SS clear height and the setback distance. The thickness shall comply with the following requirements:

- a. The minimum SS wall thickness shall be in accordance with TABLE 2.3.1.
- b. Wall thickness of any SS or NS within the SS tower shall not be less than the wall thickness of the SS or NS above it.

Figures & Tables

TABLE 2.3.1 : REQUIRED MINIMUM SS AND NS WALL THICKNESS

Storey Height (SH) (mm)	SS/NS Clear Height (Ht) (mm)	Setback Distance of SS Wall (mm)	Wall Thickness (mm)
SH ≤ 4000	2400 ≤ Ht ≤ 3400	≤ 6000	300
		> 6000	250
	3400 < Ht ≤ 3900	≤ 6000	325
		> 6000	275
4000 < SH ≤ 6000	2400 ≤ Ht ≤ 3400	≤ 7000	300
		> 7000	250
	3400 < Ht ≤ 3900	≤ 7000	325
		> 7000	275
6000 < SH ≤ 8000	2400 ≤ Ht ≤ 3400	≤ 8000	300
		> 8000	250
	3400 < Ht ≤ 3900	≤ 8000	325
		> 8000	275
8000 < SH ≤ 10000	2400 ≤ Ht ≤ 3400	≤ 9000	300
		> 9000	250
	3400 < Ht ≤ 3900	≤ 9000	325
		> 9000	275

- c. Internal common wall between 2 adjacent SS shall be at least 200mm thick. Refer to FIGURE 2.3.1.

Figures & Tables

FIGURE 2.3.1: INTERNAL COMMON WALL BETWEEN TWO SS

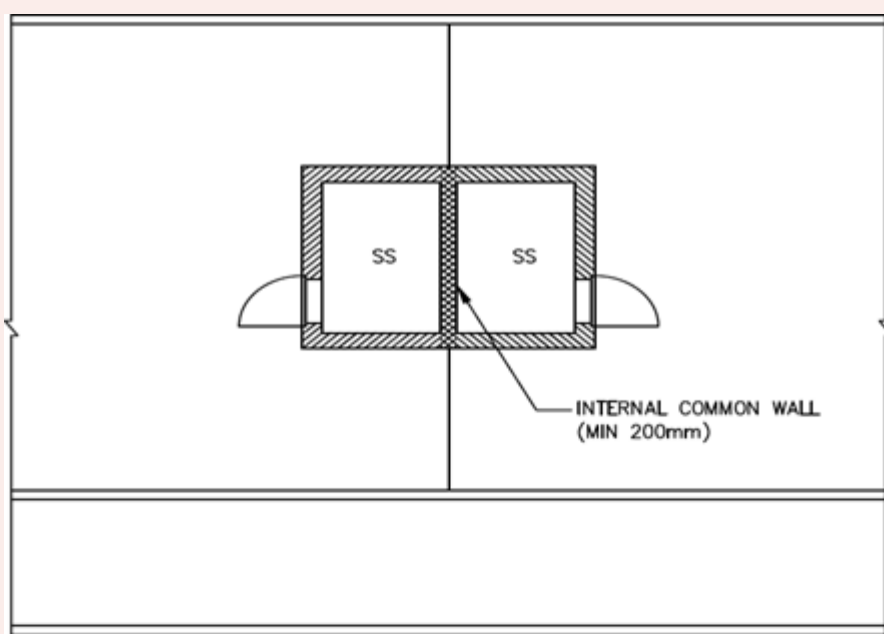

ALTERNATIVE 1

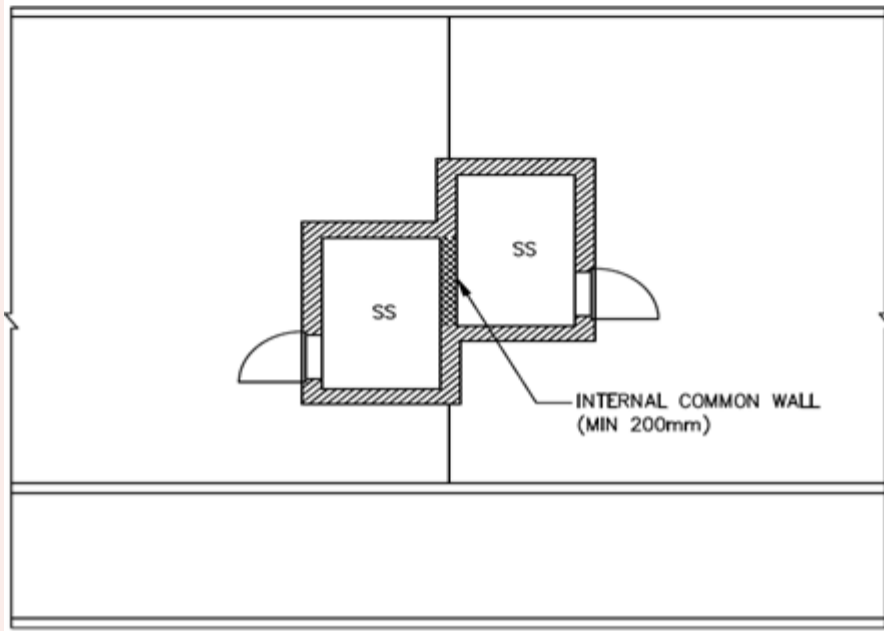

ALTERNATIVE 2

d. The minimum internal common wall thickness between SS and enclosed NS shall be 200mm. The minimum internal common wall thickness between SS and non-enclosed NS shall be 300mm. Refer to FIGURE 2.12.2(i).

Figures & Tables

FIGURE 2.12.2(i): SS WITH NS COMPARTMENT WITH LAST BOTTOM-MOST SS DOOR ON 300MM THICK INTERNAL WALL

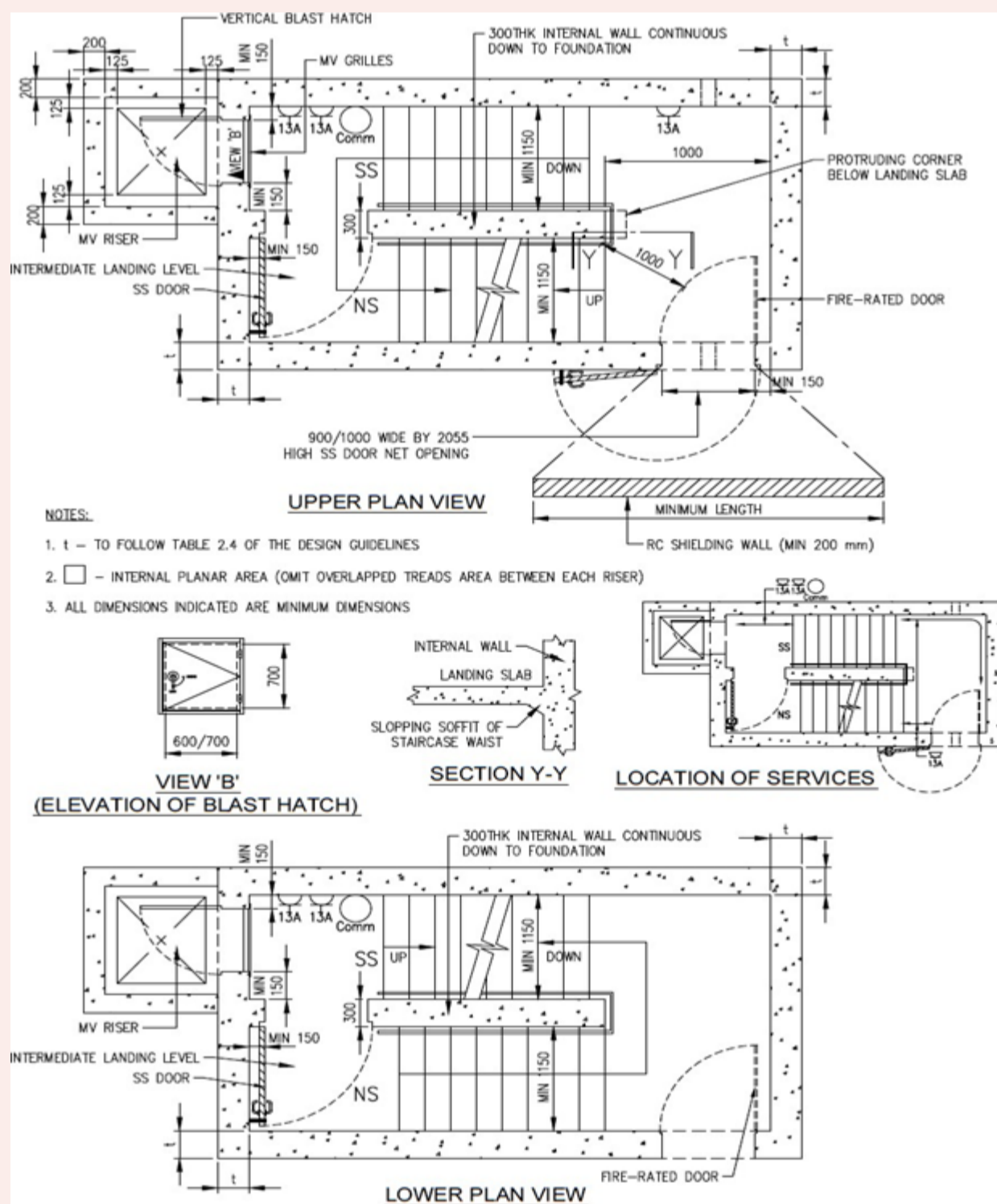

e. For internal SS and S/C SS length more than 8000mm, an additional 25mm thickness shall be provided to the affected SS wall. Refer to FIGURE 2.2.1(a) and 2.2.1(b).

Figures & Tables

FIGURE 2.2.1(a): TYPICAL LAYOUT OF SS

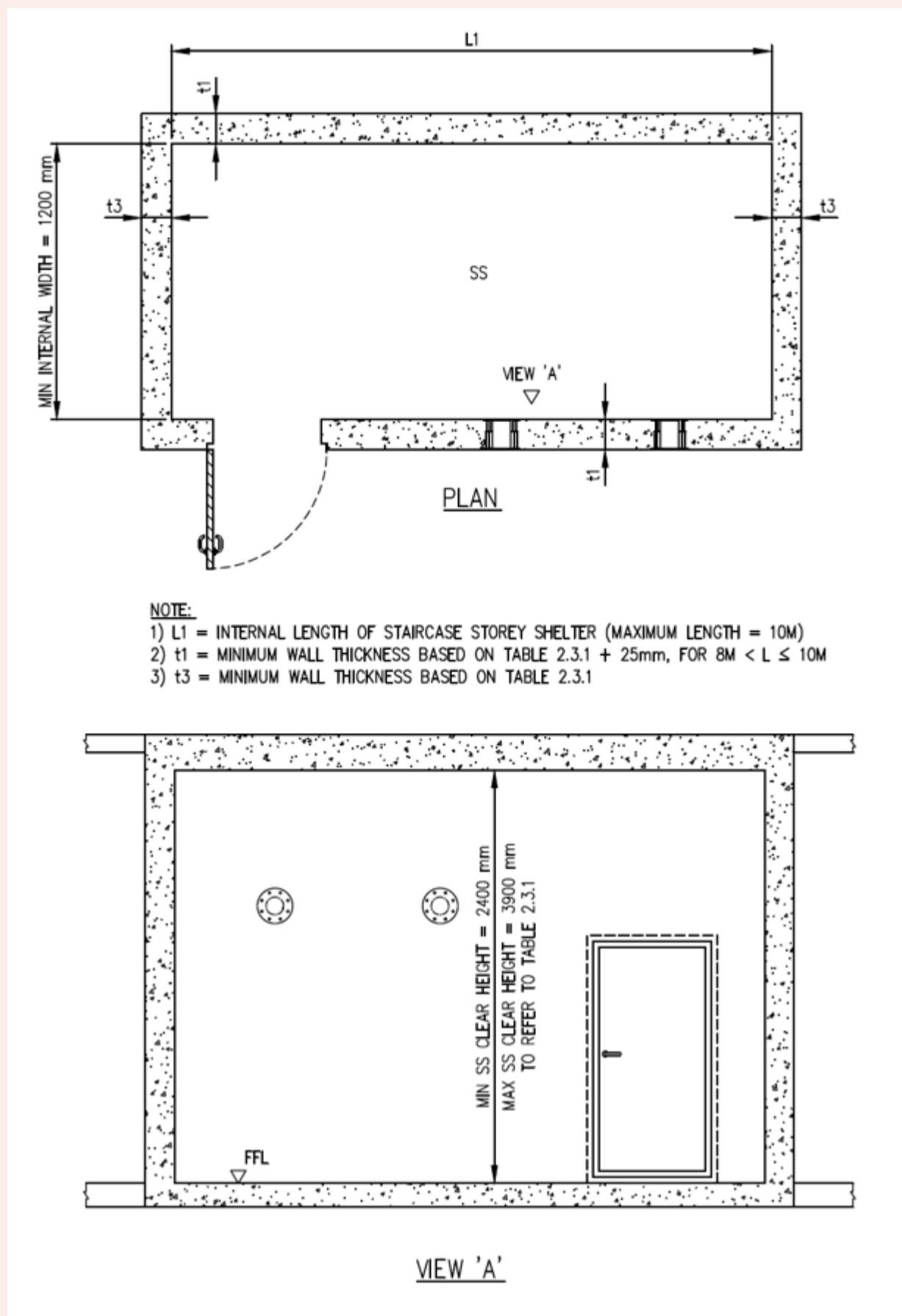
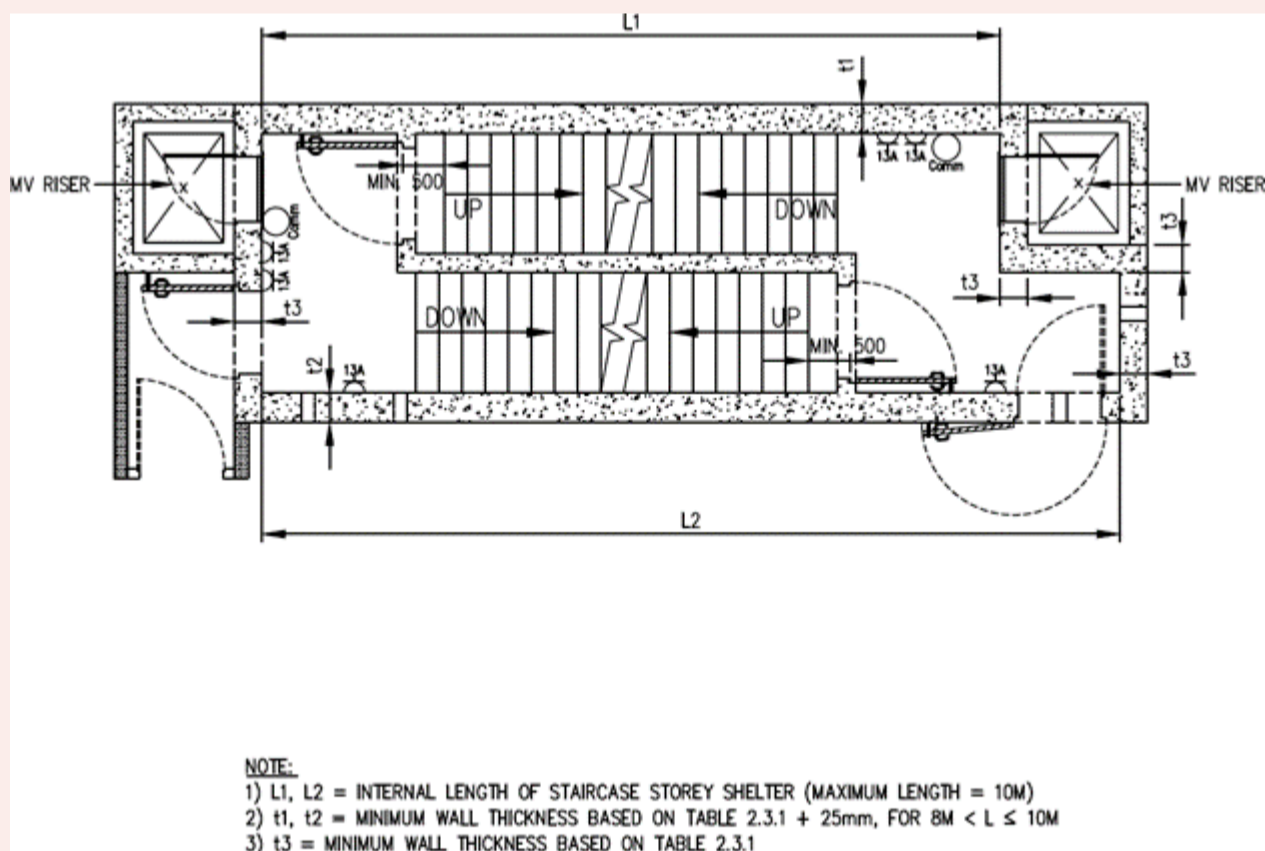

FIGURE 2.2.1(b): TYPICAL LAYOUT OF S/C SS



2.3.2 Slab Thickness of SS and Enclosed NS

The minimum dimensions of members forming part of the SS tower shall be as follows:

- a. Ceiling slab of top-most SS or S/C SS or scissor S/C SS – 300mm. Refer to FIGURE 2.3.2.

Figures & Tables

FIGURE 2.3.2: SS TOWER SHOWING SS AND NS (WITH ENCLOSED AND NON-ENCLOSED NS WALL) SLAB THICKNESS

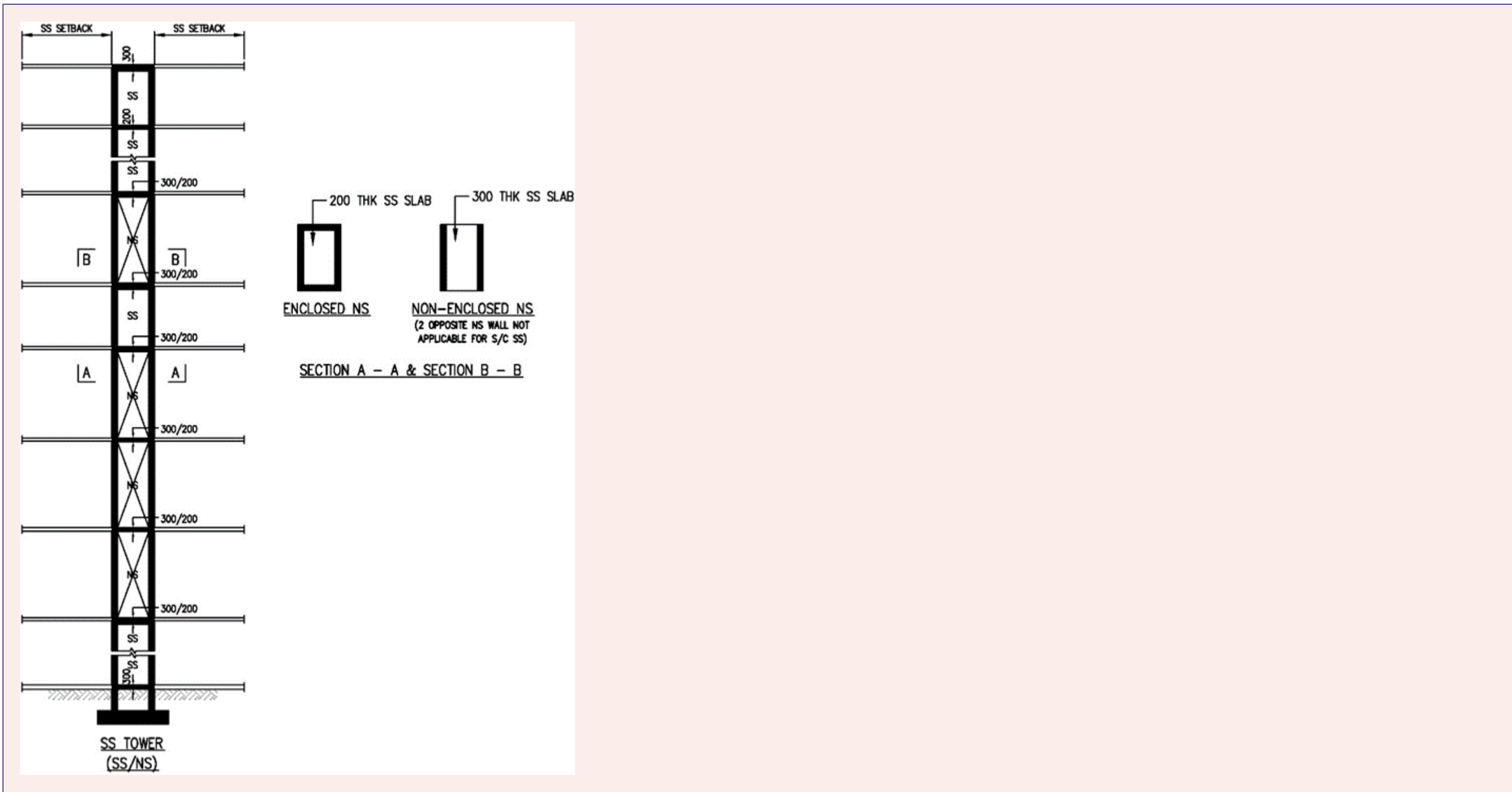

d. Slab between SS or S/C SS and enclosed NS - 200mm - Refer to FIGURE 2.3.2.

Figures & Tables

FIGURE 2.3.2: SS TOWER SHOWING SS AND NS (WITH ENCLOSED AND NON-ENCLOSED NS WALL) SLAB THICKNESS

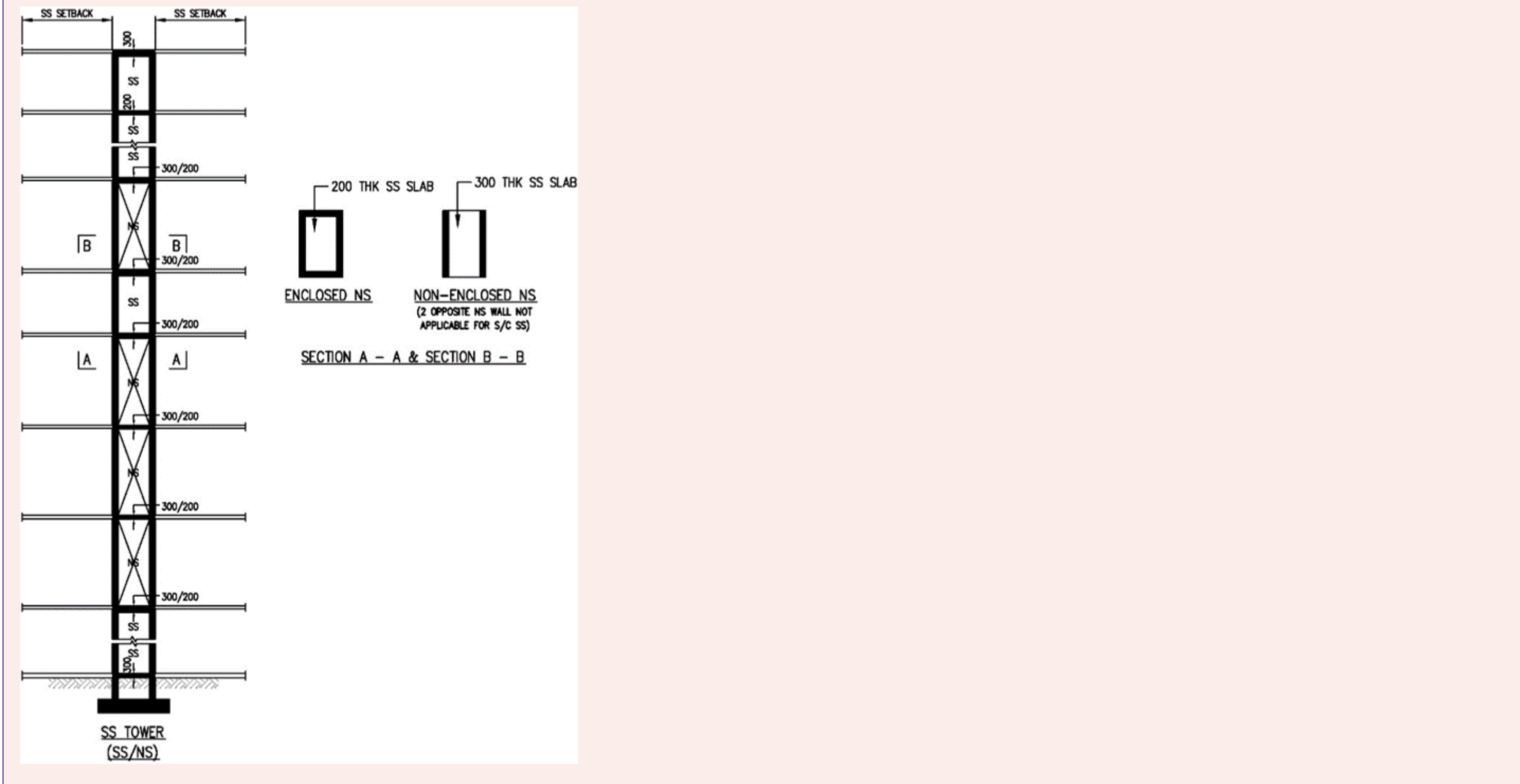

2.3.3 Slab Thickness of SS and Non-Enclosed NS

a. Floor slab of bottom-most SS that is directly supported by non-enclosed NS or NS wall - 300mm. Refer to FIGURE 2.3.2.

Figures & Tables

FIGURE 2.3.2: SS TOWER SHOWING SS AND NS (WITH ENCLOSED AND NON-ENCLOSED NS WALL) SLAB THICKNESS

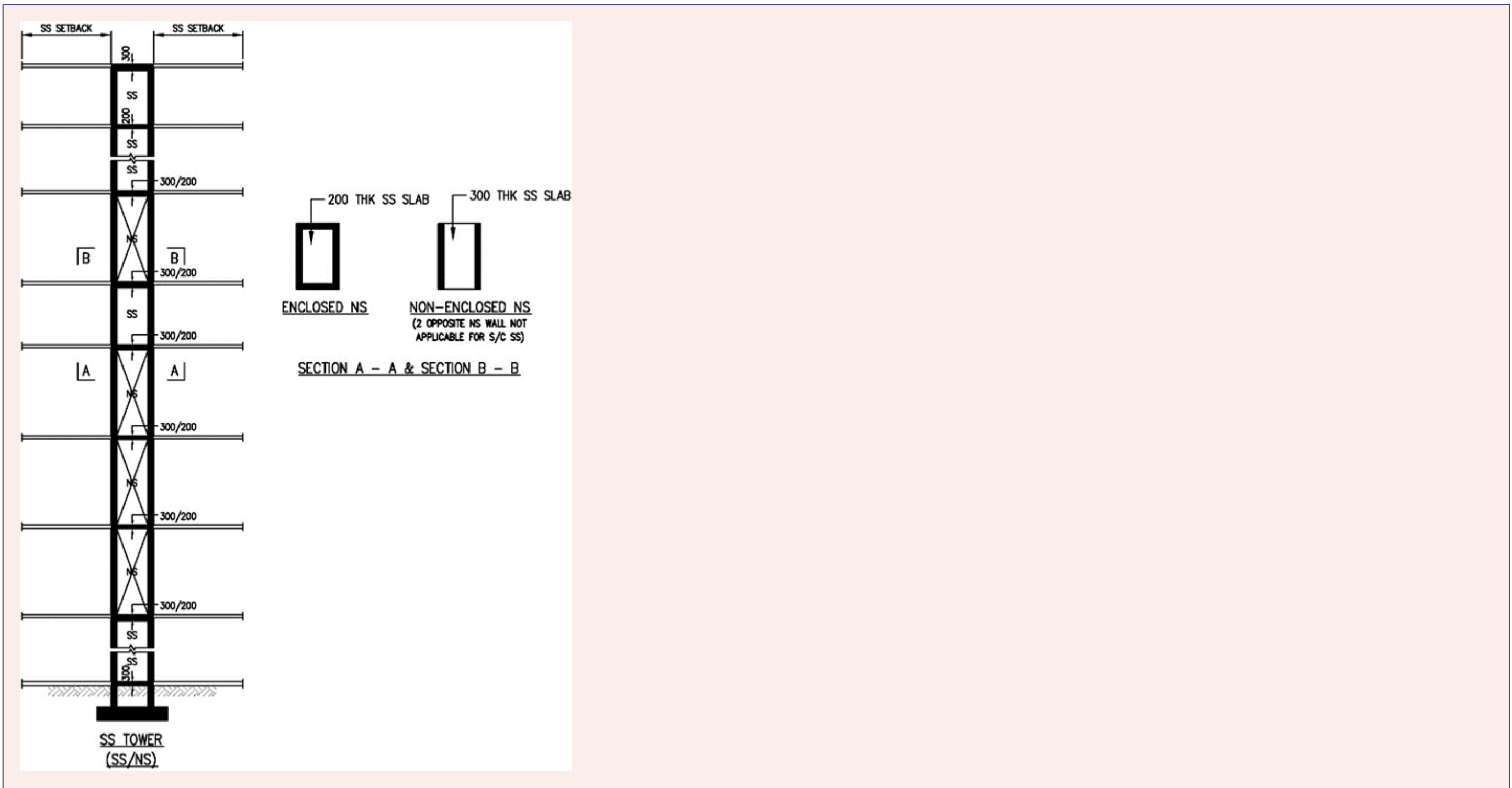

- b. Ceiling slab of SS which is below non-enclosed NS or NS wall - 300mm.
- c. Slab between two non-enclosed NS - 300mm.

CLAUSE 2.4 LOCATION OF SS

2.4.1 SS Position

- A SS has to be positioned such that the setback distance of each SS wall shall be as large as practicable and shall not be less than the minimum specified setback distance. Setback distance is provided by horizontal RC slab/ trellis at the SS ceiling level or above.
- Each of the dwelling units served by the SS shall have at least one exit door at the same storey as the SS. The travel distance between the SS door and the exit door (at the same storey as the SS) of any dwelling unit served by the SS shall not exceed 40 metres. Refer to FIGURE. 2.4.1

Figures & Tables

FIGURE 2.4.1: SS LOCATED NEXT TO LIFT SHAFT

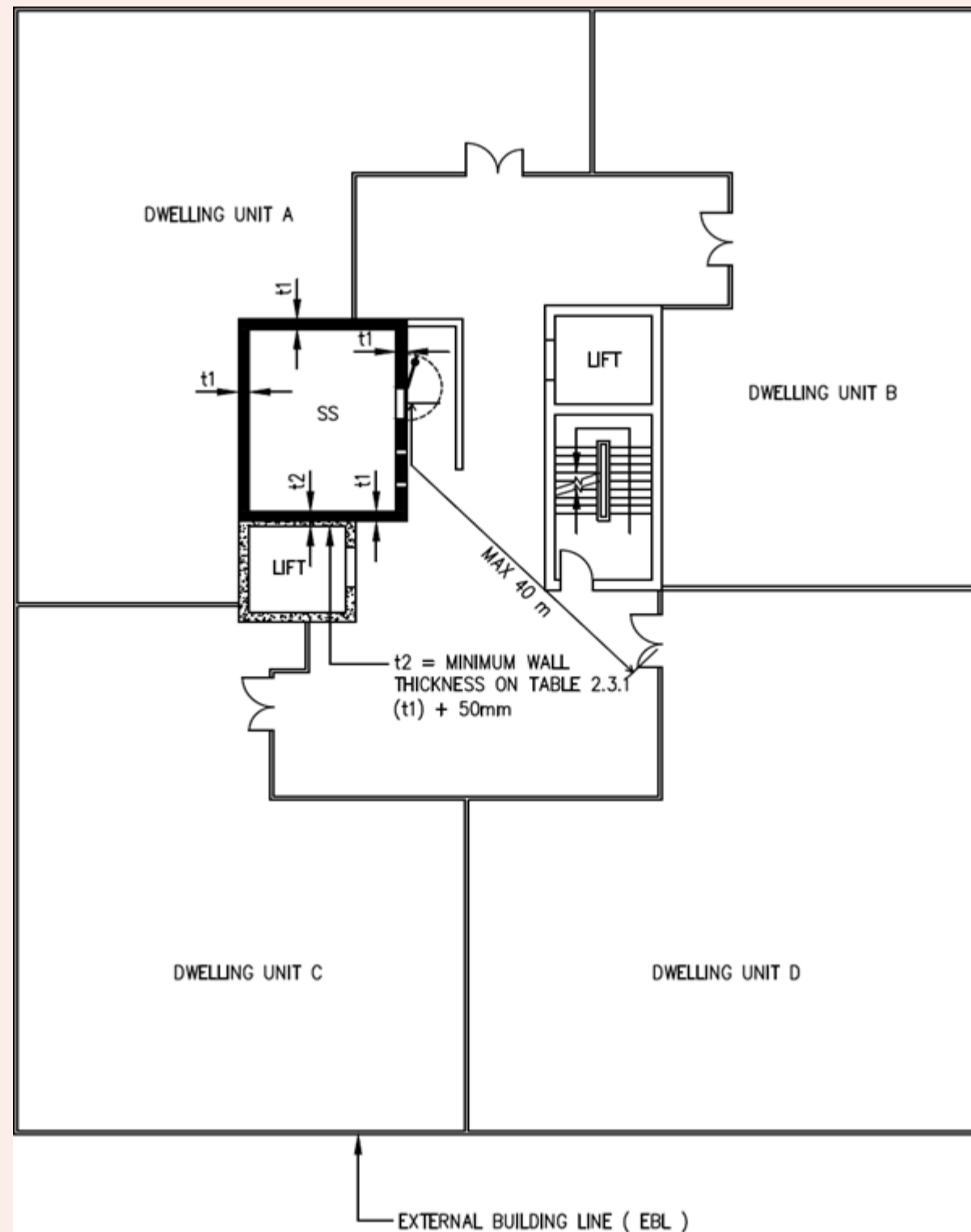

2.4.2 SS Tower

- In a building of more than one-storey, the SS (or NS, where applicable) on every storey shall be located one on top of the other to form a vertical tower with its walls founded directly to the foundation. Refer to FIGURE 2.4.2.

Figures & Tables

FIGURE 2.4.2: SCHEMATIC SECTION OF SS TOWER

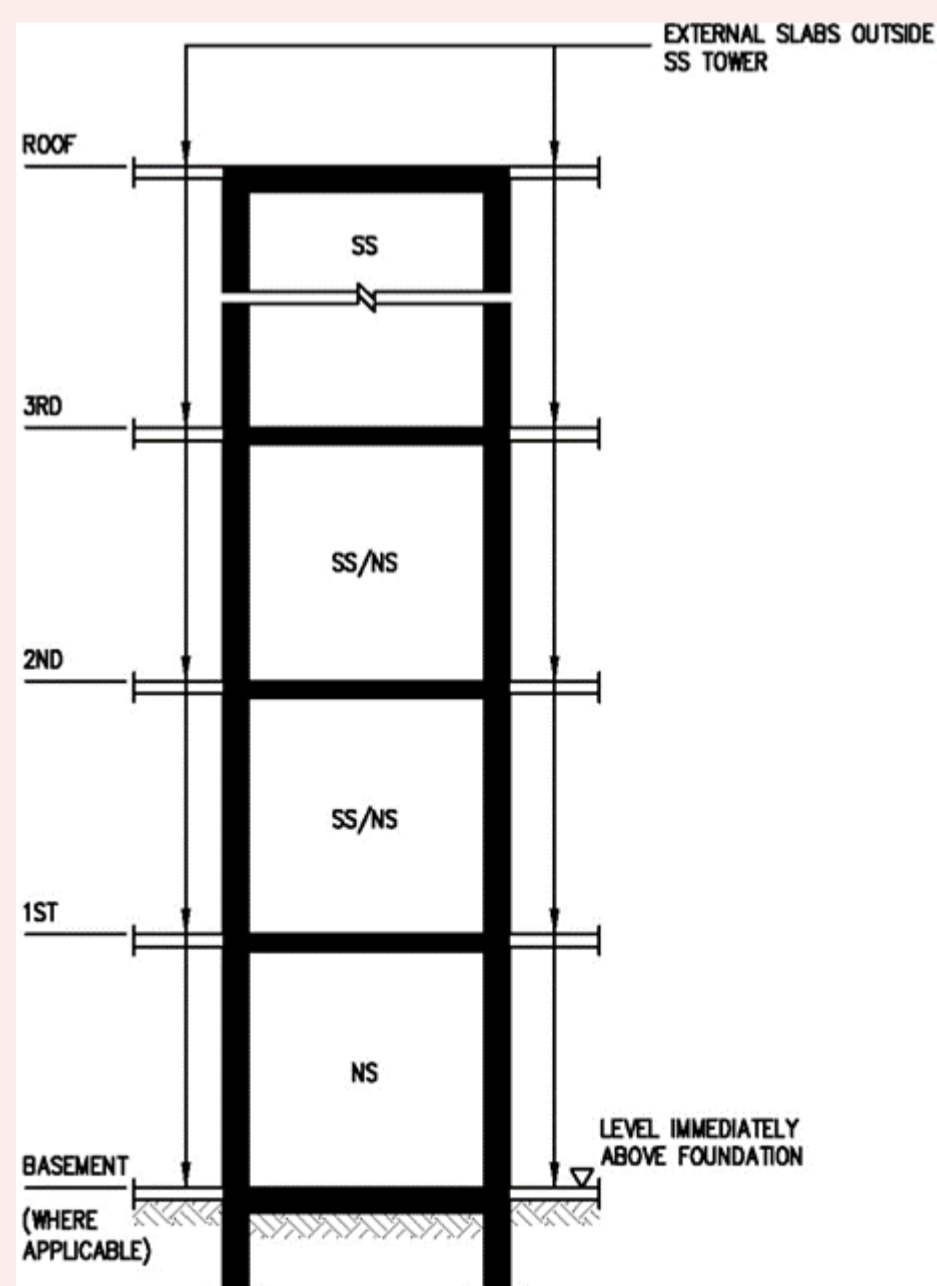

NOTES
1. SS TOWER WITH SS AND NS WHERE APPLICABLE

- The space within the NS of the SS tower is not intended for protection of occupants during war emergency.
- In the case of S/C SS or scissor S/C SS, the SS and NS wall shall be continuous to foundation, except where there are fire discharge openings at fire discharge levels. The fire discharge openings shall be located such that all corners of the S/C SS walls are continuous to foundation

2.4.3 Setback Distances of SS Walls (without Reinforced Concrete Down-hang Beams)

a. The SS walls shall be located at minimum setback distances as shown in FIGURE 2.4.3(a) to 2.4.3(c) and shall comply with TABLE 2.4.3.

Figures & Tables

FIGURE 2.4.3(a) to 2.4.3(c) and TABLE 2.4.3.

FIGURE 2.4.3(a): REQUIREMENT ON SETBACK DISTANCE OF SS WALLS (WITHOUT DOWN-HANG BEAM) (FOR 2500MM < STOREY HEIGHT | 2800MM)

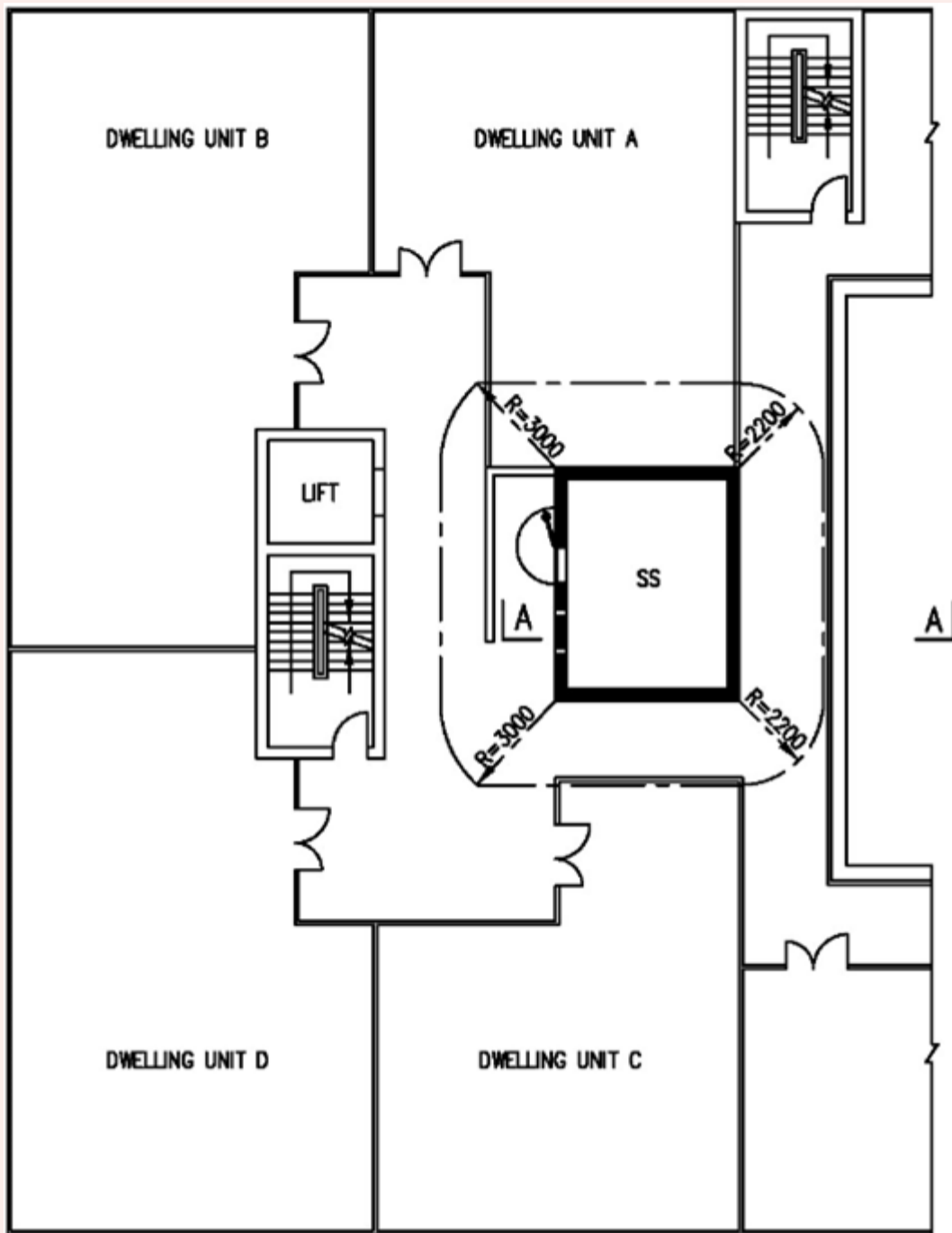

FIGURE 2.4.3(b): REQUIREMENT ON SETBACK DISTANCE OF SS WALLS (WITHOUT DOWN-HANG BEAM) (FOR 3500MM < STOREY HEIGHT | 4000MM)

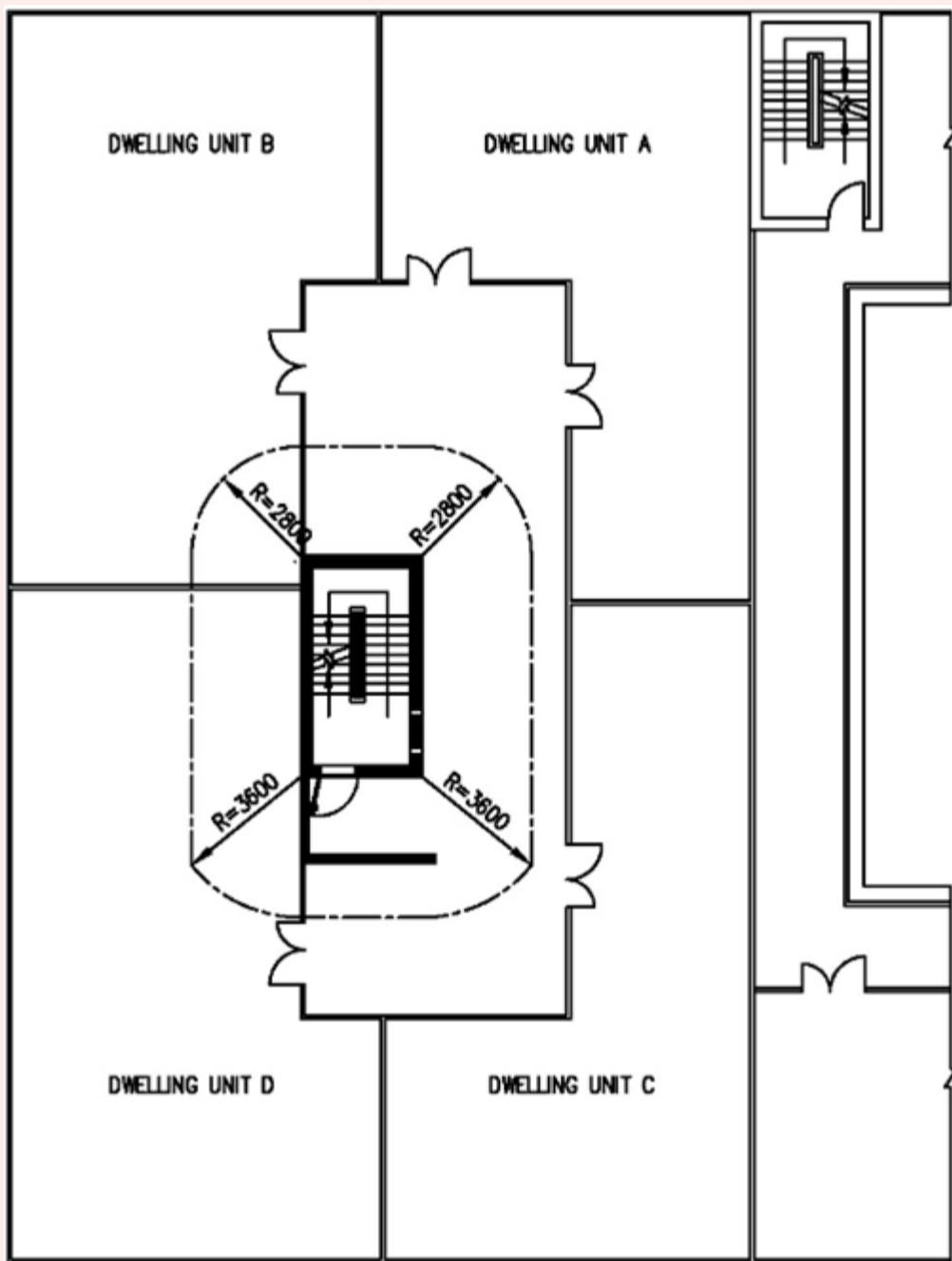

FIGURE 2.4.3(c): SETBACK DISTANCE OF SS WALLS (WITHOUT DOWN-HANG BEAM)

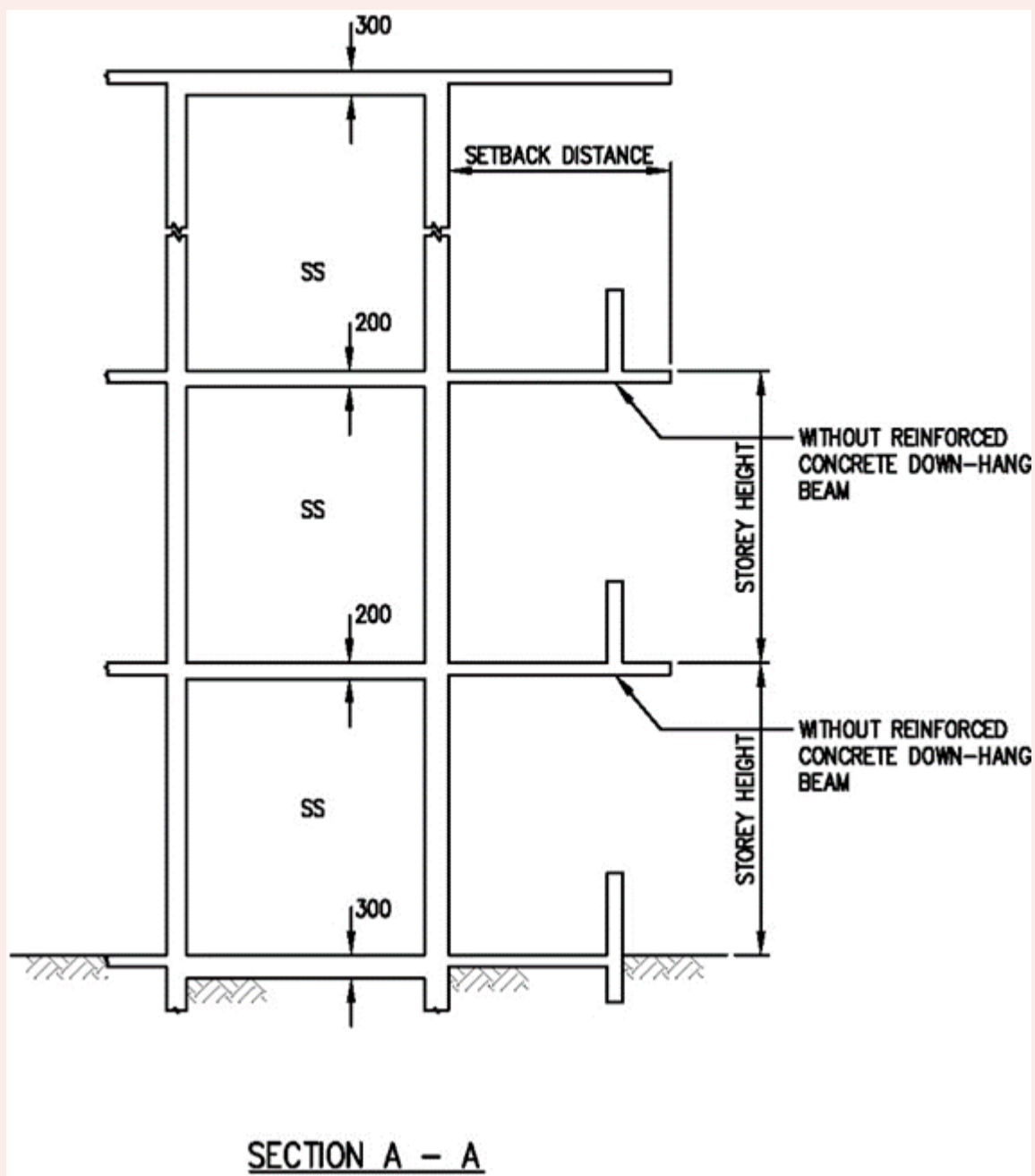

TABLE 2.4.3 : MINIMUM SETBACK DISTANCES OF SS WALLS WITHOUT REINFORCED CONCRETE DOWN-HANG BEAM

Storey Height (SH) (mm) Column(1)	Setback Distance of SS Wall with SS Door (mm) Column(2)	Setback Distance of SS walls without SS Door (mm) Column(3)
2200 < SH ≤ 2500	3000	2100
2500 < SH ≤ 2800	3000	2200
2800 < SH ≤ 3100	3200	2400
3100 < SH ≤ 3200	3250	2450
3200 < SH ≤ 3400	3300	2500
3400 < SH ≤ 3500	3400	2600
3500 < SH ≤ 4000	3600	2800
4000 < SH ≤ 4500	3850	3050
4500 < SH ≤ 5000	4100	3300
5000 < SH ≤ 5500	4300	3500
5500 < SH ≤ 6000	4550	3750
6000 < SH ≤ 6500	4800	4000
6500 < SH ≤ 7000	5000	4200
7000 < SH ≤ 7500	5250	4450
7500 < SH ≤ 8000	5500	4700
8000 < SH ≤ 8500	5750	4950
8500 < SH ≤ 9000	6000	5200
9000 < SH ≤ 9500	6250	5450
9500 < SH ≤ 10000	6500	5700

b. For SS wall (with door), the setback distance requirement shall be read in conjunction with [Clause 2.5.4](#).

c. Where the storey height of a SS on the first storey is up to 3.6m and is greater than the storey heights of other SS above it, the minimum setback distances of the SS on the first storey may be the same as the setback distances of the SS above it.

d. For SS walls (where the SS door is not located), trellis constructed of RC or steel hollow section may be used to make up for the shortfall in setback distance. However, a minimum 1200mm RC ceiling slab from the SS wall shall be provided. Refer to FIGURE 2.4.3(d).

Figures & Tables

FIGURE 2.4.3(d): USAGE OF TRELLIS (RC/STEEL HOLLOW SECTION) TO MAKE UP FOR SHORTFALL IN SETBACK DISTANCE (SS)

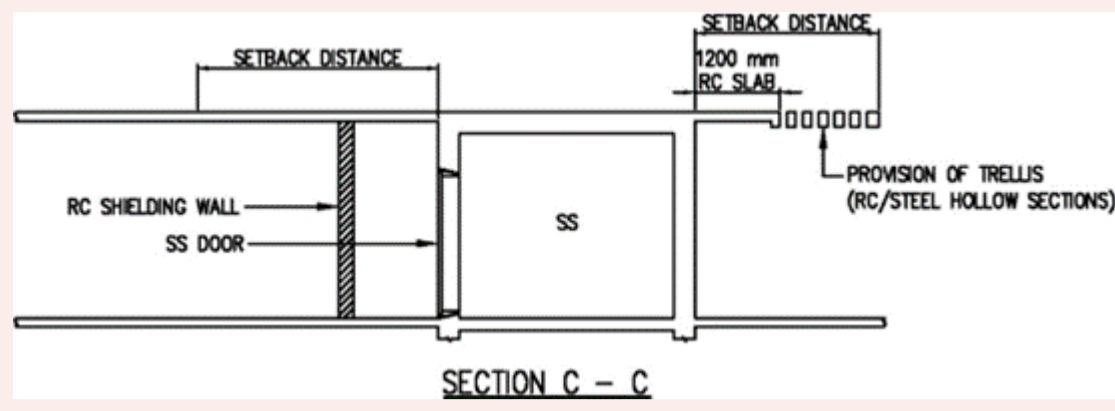

e. A perpendicular or parallel trellis arrangement, or a combination of both, with respect to the SS wall concerned, shall comply with the geometrical configuration as shown in FIGURE 2.4.3(e) and 2.4.3(f).

Figures & Tables

FIGURE 2.4.3(e): USAGE OF TRELLIS (RC/STEEL HOLLOW SECTION) TO MAKE UP FOR SHORTFALL IN SETBACK DISTANCE (SS)

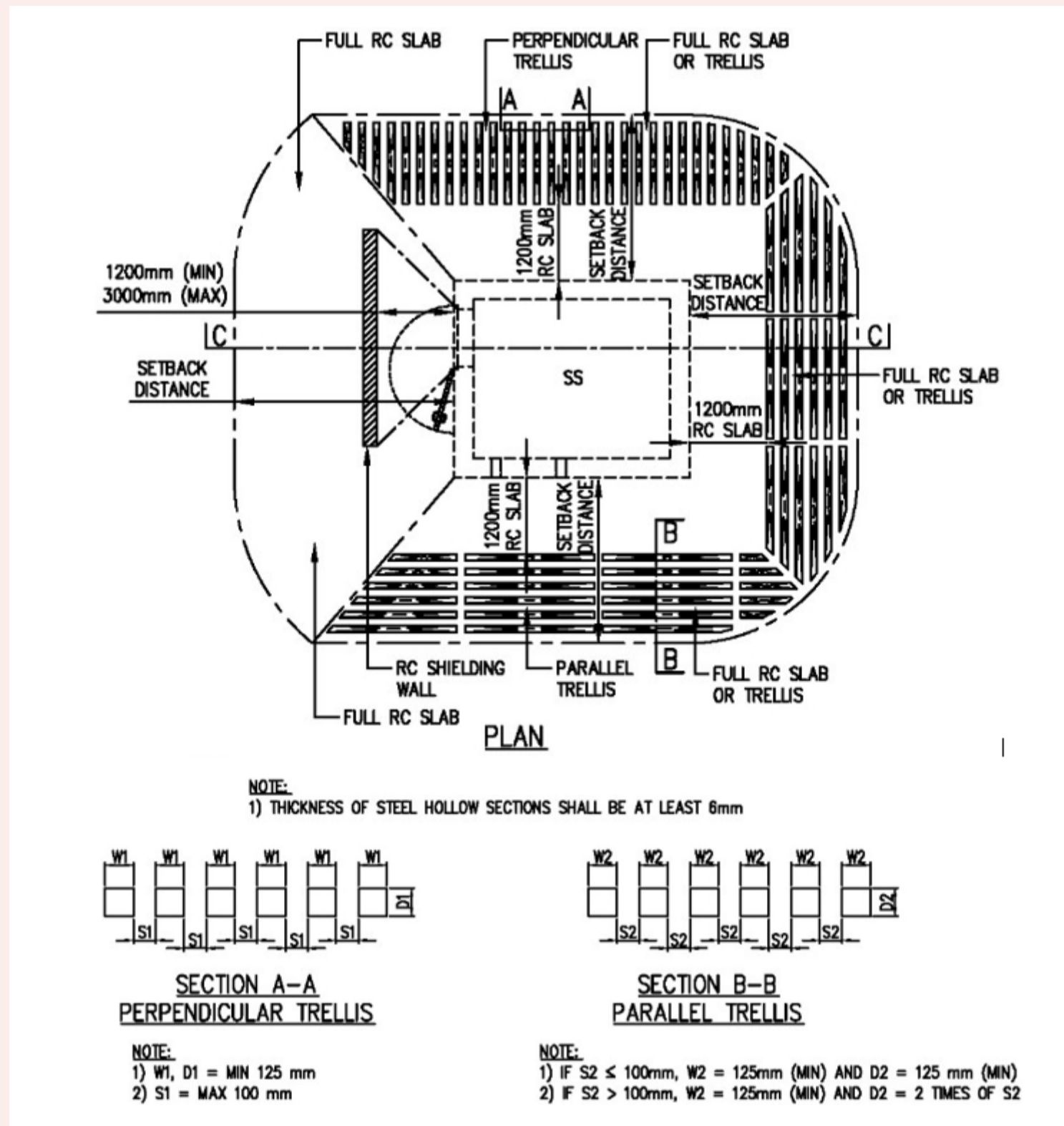
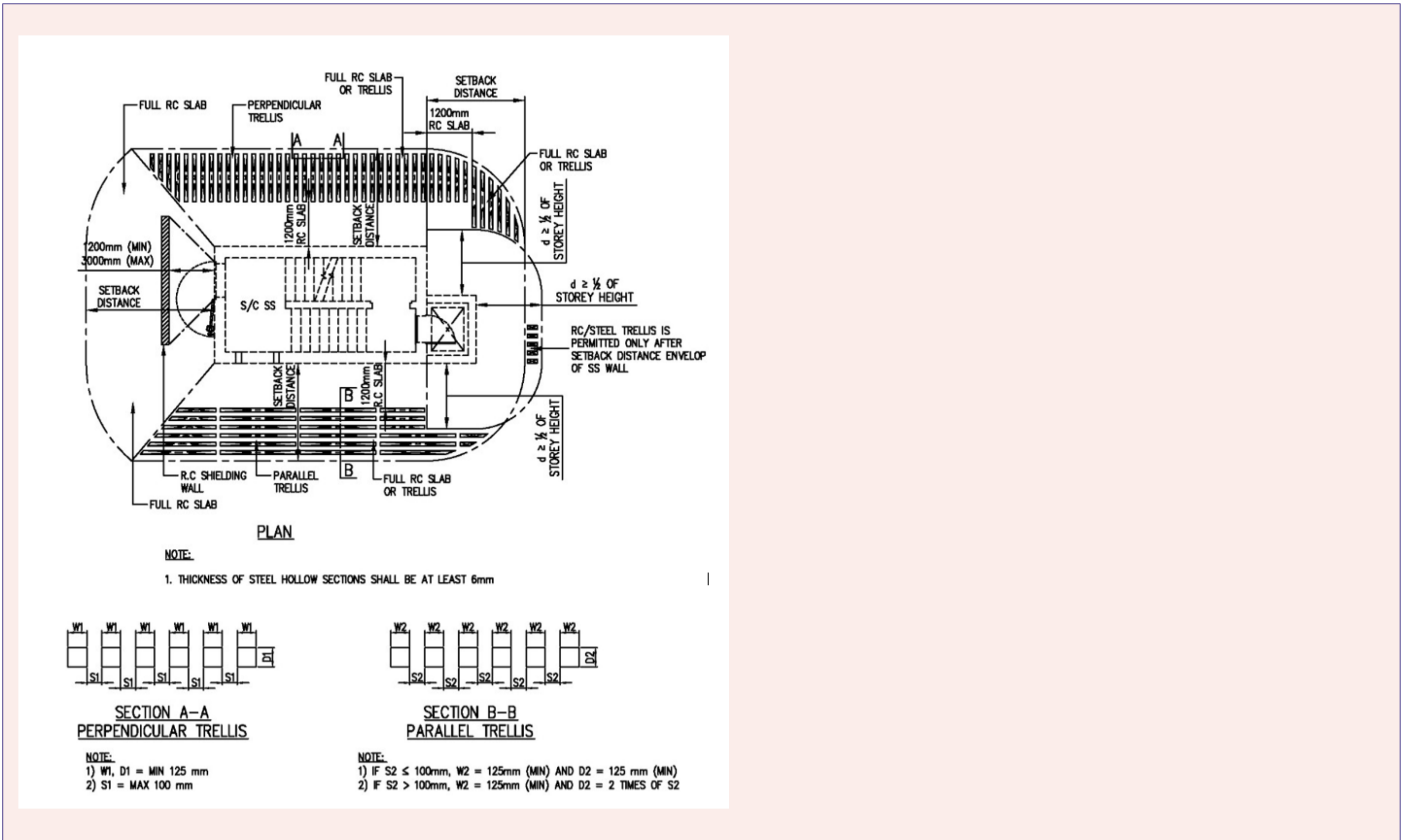

FIGURE 2.4.3(f): USAGE OF TRELLIS (RC/STEEL HOLLOW SECTION) TO MAKE UP FOR SHORTFALL IN SETBACK DISTANCE (S/C SS)



2.4.4 Setback Distances of SS Walls (with Reinforced Concrete Down-hang Beams)

a. Where RC down-hang beams are provided within setback and more than 1200mm away from the SS wall, the minimum setback distance of these SS walls can be reduced based on the effective storey height and in accordance with TABLE 2.4.4. The effective storey height is determined by the storey height less the dimension 'd' of the RC down-hang beam. Refer to FIGURE 2.4.4(a) and 2.4.4(b).

Figures & Tables

TABLE 2.4.4 : MINIMUM SETBACK DISTANCES OF SS WALLS WITH REINFORCED CONCRETE DOWN-HANG BEAM

Effective Storey Height (SH) (mm) Column(1)	Setback Distance of SS Wall with SS Door (mm) Column(2)	Setback Distance of SS walls without SS Door (mm) Column(3)
2200 < SH ≤ 2500	3000	2100
2500 < SH ≤ 2800	3000	2200
2800 < SH ≤ 3100	3200	2400
3100 < SH ≤ 3200	3250	2450
3200 < SH ≤ 3400	3300	2500
3400 < SH ≤ 3500	3400	2600
3500 < SH ≤ 4000	3600	2800
4000 < SH ≤ 4500	3850	3050
4500 < SH ≤ 5000	4100	3300
5000 < SH ≤ 5500	4300	3500
5500 < SH ≤ 6000	4550	3750
6000 < SH ≤ 6500	4800	4000
6500 < SH ≤ 7000	5000	4200
7000 < SH ≤ 7500	5250	4450
7500 < SH ≤ 8000	5500	4700
8000 < SH ≤ 8500	5750	4950
8500 < SH ≤ 9000	6000	5200
9000 < SH ≤ 9500	6250	5450

FIGURE 2.4.4(a): REQUIREMENT ON SETBACK DISTANCE OF SS WALLS (WITH DOWN-HANG BEAM) (EFFECTIVE STOREY HEIGHT = STOREY HEIGHT - DIMENSION 'd' OF DOWN-HANG BEAM)

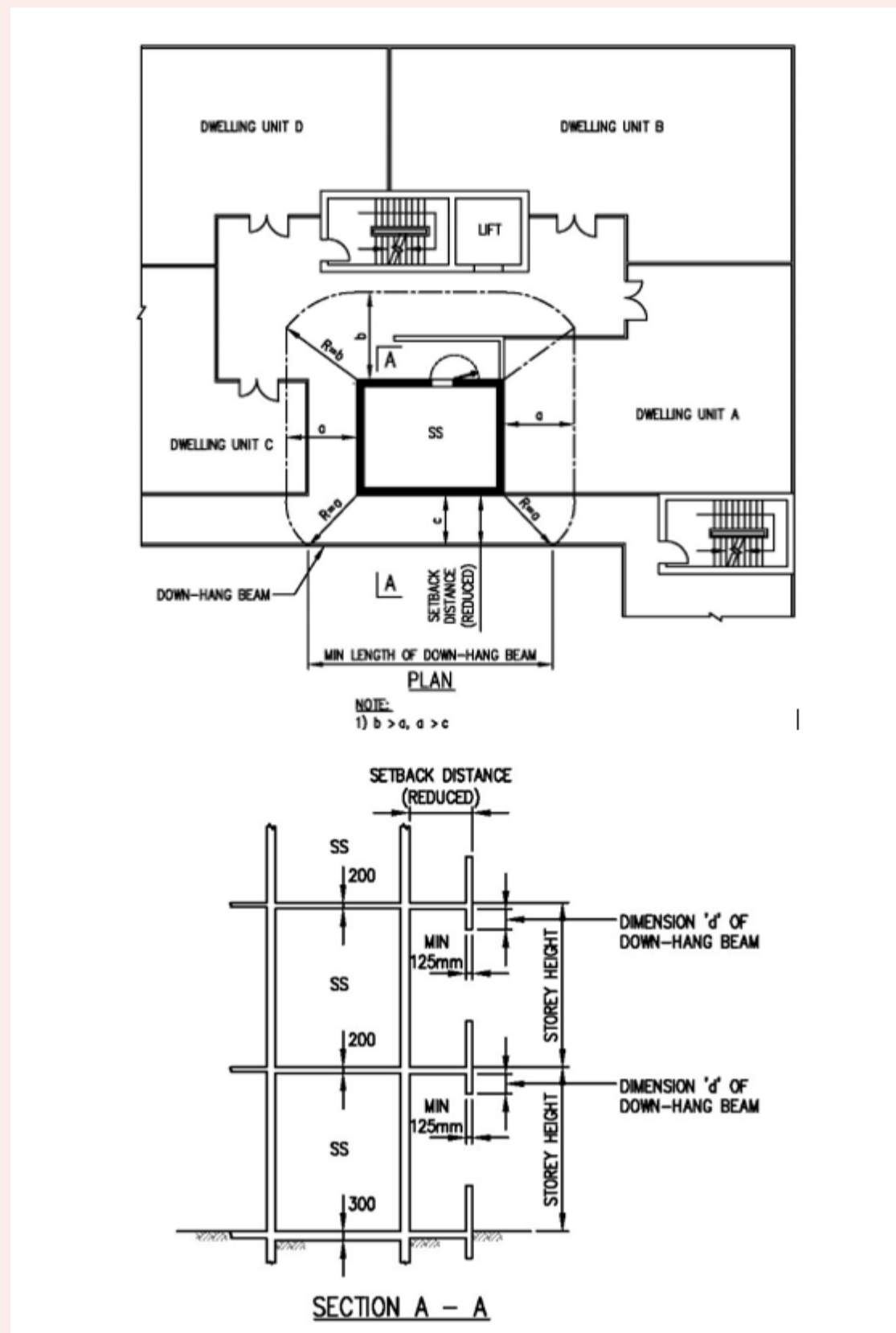
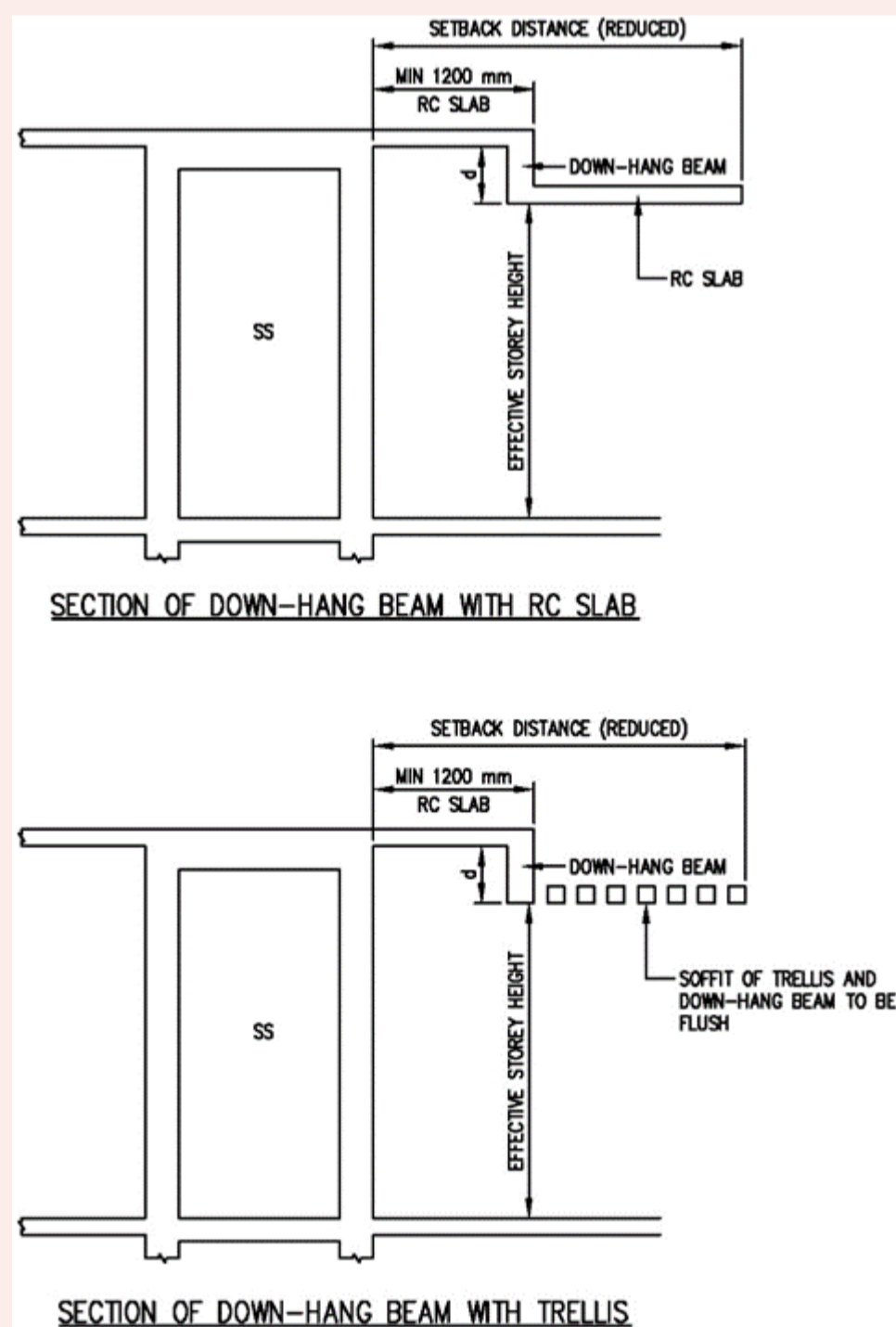

FIGURE 2.4.4(b): DOWN-HANG BEAM LOCATED ALONG THE SETBACK DISTANCE



b. For SS wall (with door), the setback distance requirement shall be read in conjunction with [Clause 2.5.4](#).

c. [Clause 2.4.4](#) shall apply only if the width of the reinforced concrete down-hang beam is at least 125mm.

d. Where the storey height of a SS on the first storey is up to 3.6m and is greater than the storey height of the SS directly above it, the minimum setback distances of the SS on the 1st storey shall be at least the same as the setback distances of the SS above it. Where a RC down-hang beam is provided at the 2nd storey ceiling slab, the same down-hang beam shall be provided at the 1st storey ceiling slab.

e. For SS walls (where the SS door is not located), RC ledge or trellis constructed of RC or steel hollow section may be used to make up for the shortfall in setback distance. However, a minimum 1200mm RC ceiling slab from the SS wall shall be provided as shown in [FIGURE 2.4.4\(b\)](#).

Figures & Tables

FIGURE 2.4.4(b): DOWN-HANG BEAM LOCATED ALONG THE SETBACK DISTANCE

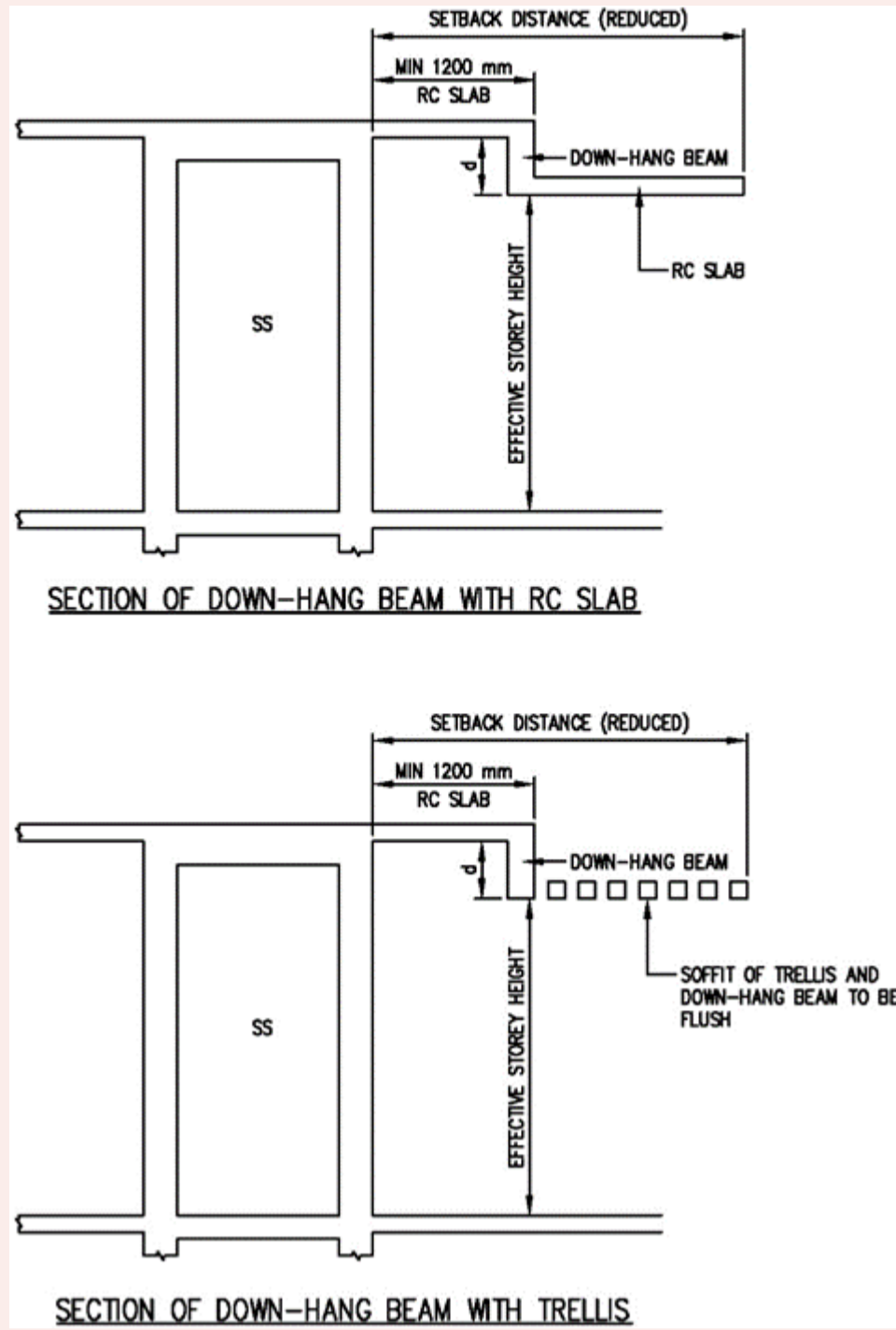

f. A perpendicular or parallel trellis arrangement, or a combination of both, with respect to the SS wall concerned, shall comply with the geometrical configuration as shown in FIGURE 2.4.3(e) and 2.4.3(f).

Figures & Tables

FIGURE 2.4.3(e): USAGE OF TRELLIS (RC/STEEL HOLLOW SECTION) TO MAKE UP FOR SHORTFALL IN SETBACK DISTANCE (SS)

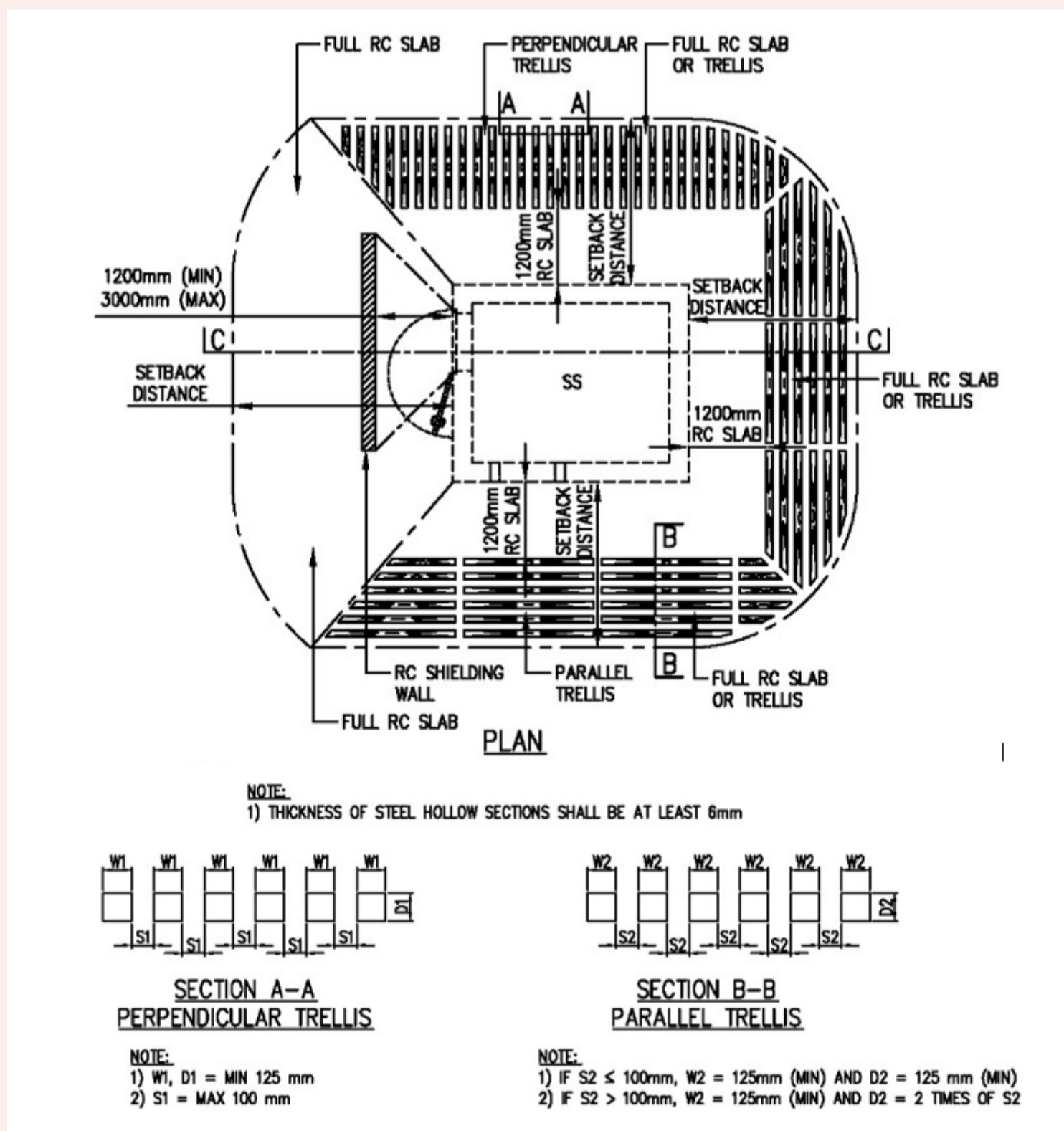
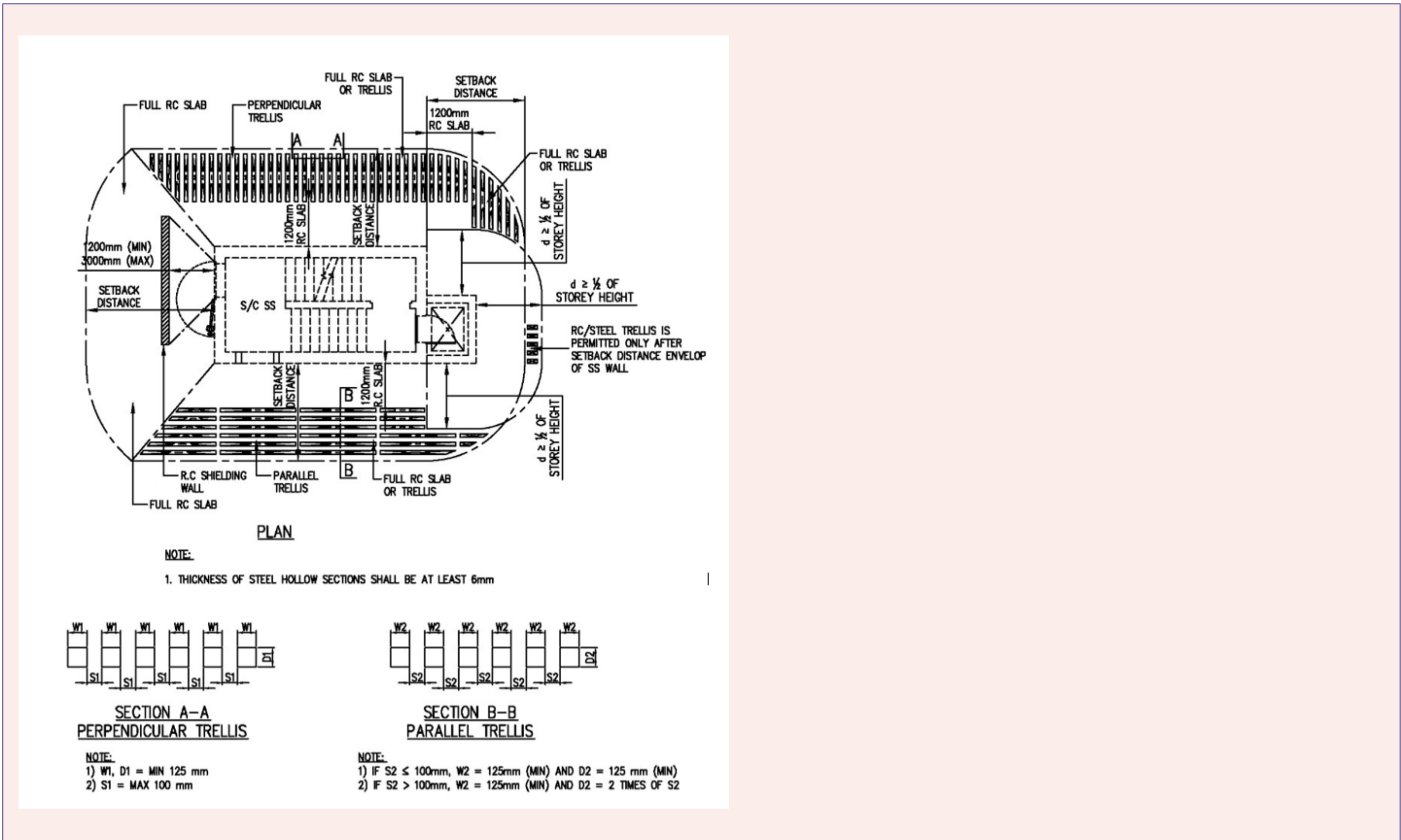

FIGURE 2.4.3(f): USAGE OF TRELLIS (RC/STEEL HOLLOW SECTION) TO MAKE UP FOR SHORTFALL IN SETBACK DISTANCE (S/C SS)



2.4.5 RC Lift Core or/ and RC Refuse Chute or/ and Service Risers, within Setback Distances of SS Walls

a. RC lift core can be located within the setback distance of SS, S/C SS or scissor S/C SS walls. An additional 50mm thickness shall be provided to the SS, S/C SS or scissor S/C SS wall abutting the RC lift core as shown in FIGURE 2.4.1.

Figures & Tables

FIGURE 2.4.1: SS LOCATED NEXT TO LIFT SHAFT

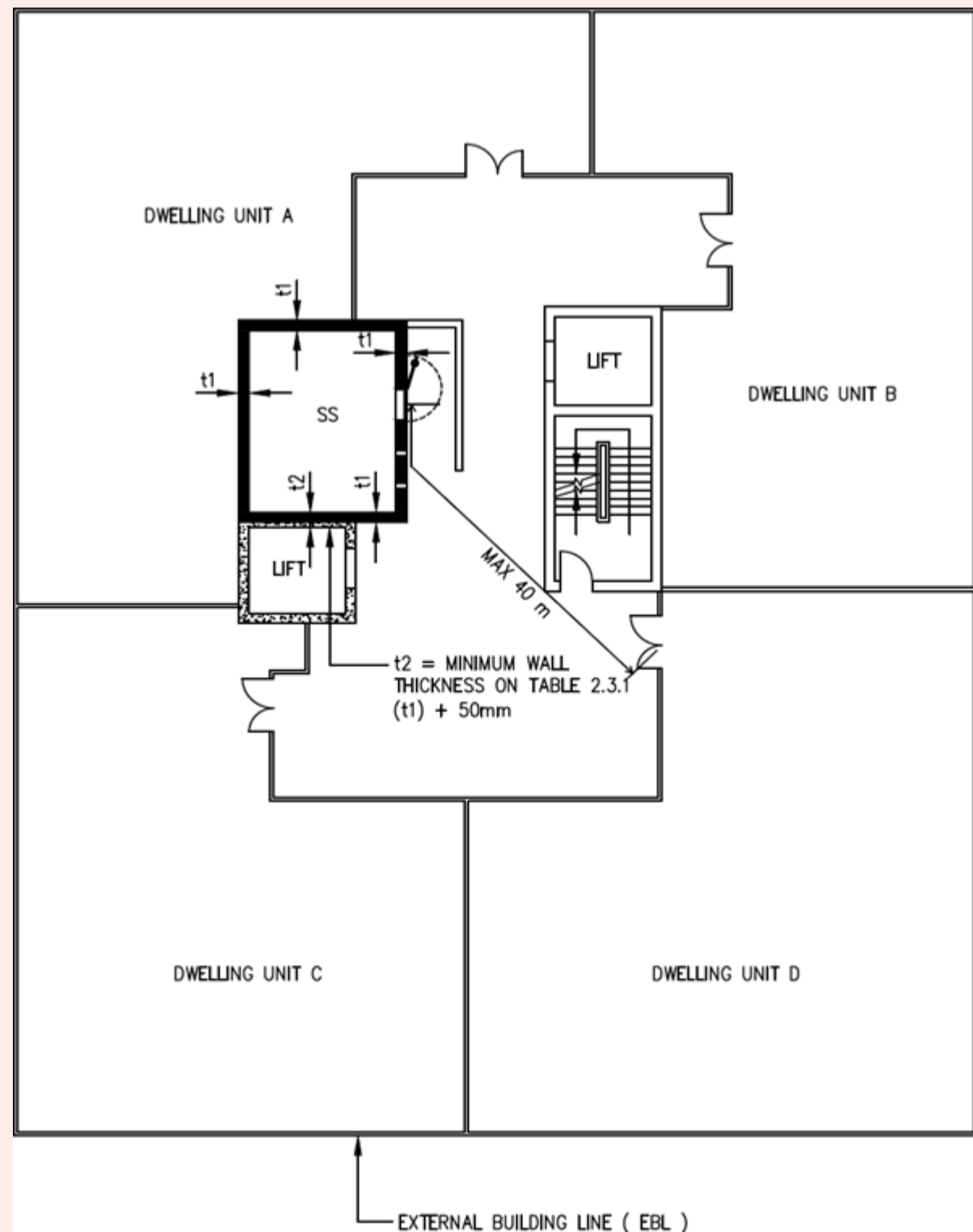

b. RC refuse chute are allowed within the setback distance envelope of the SS wall provided that the design of the RC refuse chute walls and ventilated openings at the roof level comply with the details as shown in FIGURE 2.4.5(a) and 2.4.5(b).

Figures & Tables

FIGURE 2.4.5(a): PROTECTION REQUIREMENT AT ROOF LEVEL FOR PROVISION OF RC REFUSE CHUTE LOCATED WITHIN SETBACK DISTANCE ENVELOP

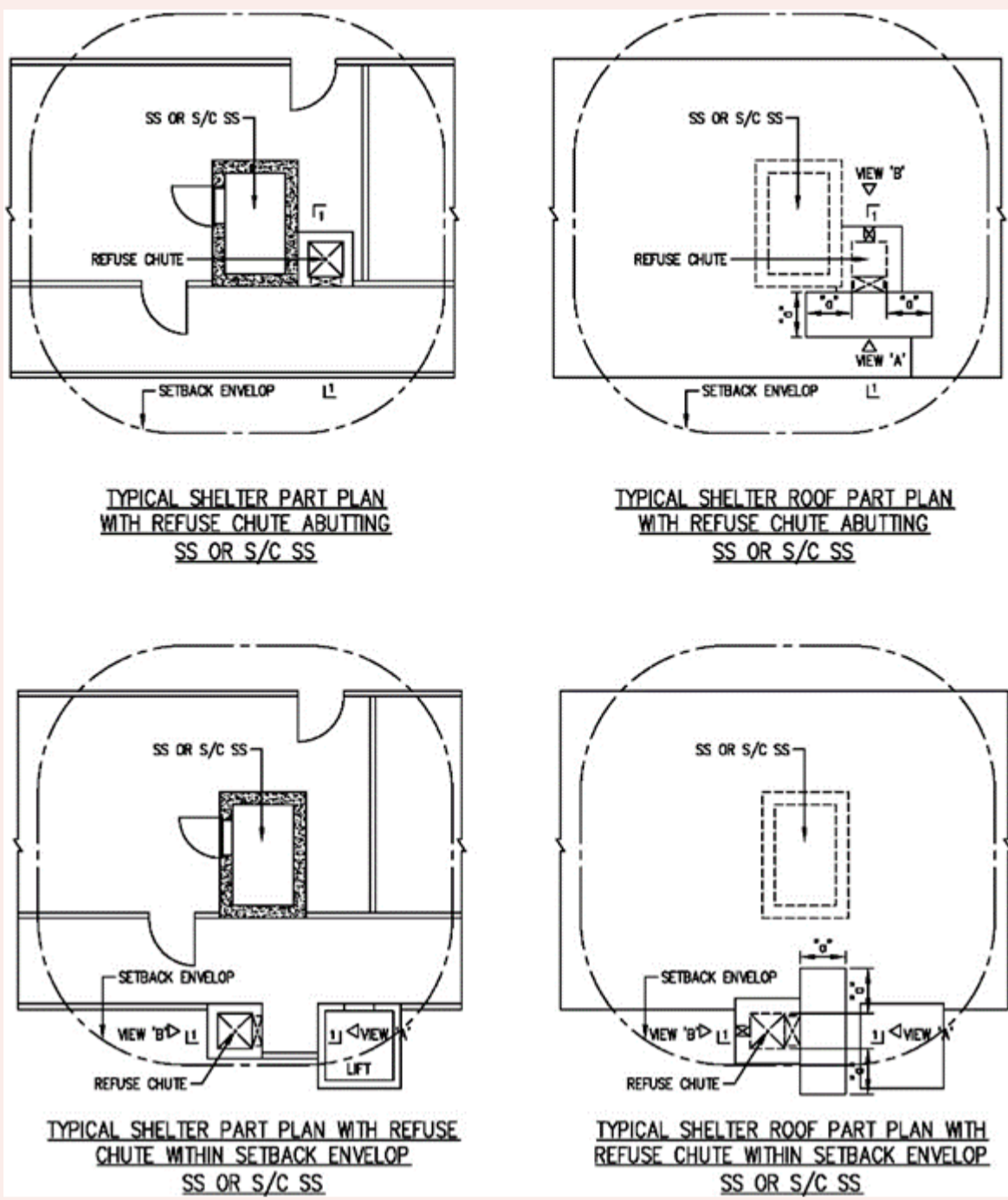
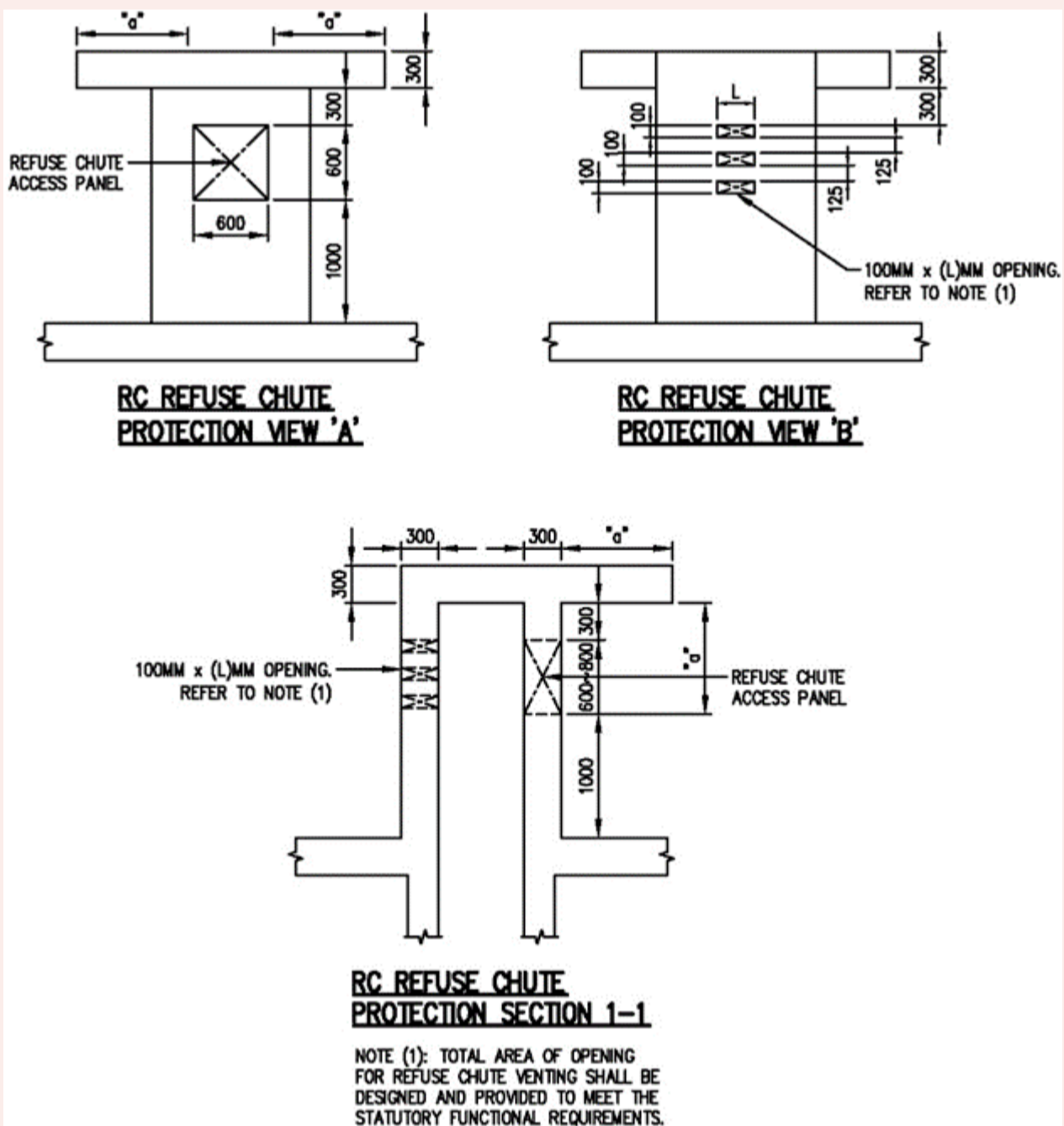

FIGURE 2.4.5(b): PROTECTION REQUIREMENT AT ROOF LEVEL FOR PROVISION OF RC REFUSE CHUTE LOCATED WITHIN SETBACK DISTANCE ENVELOPE



c. Service risers are allowed within the setback distance envelope of the SS wall (with or without door). The design shall comply with the details as shown in FIGURE 2.4.5(c) and 2.4.5(d), provided that the ceiling slab at the roof level is of reinforced concrete, and the relevant fire safety requirements for compartmentalisation of the service risers.

Figures & Tables

FIGURE 2.4.5(c): SERVICE RISERS ABUTTING S/C SS WALLS

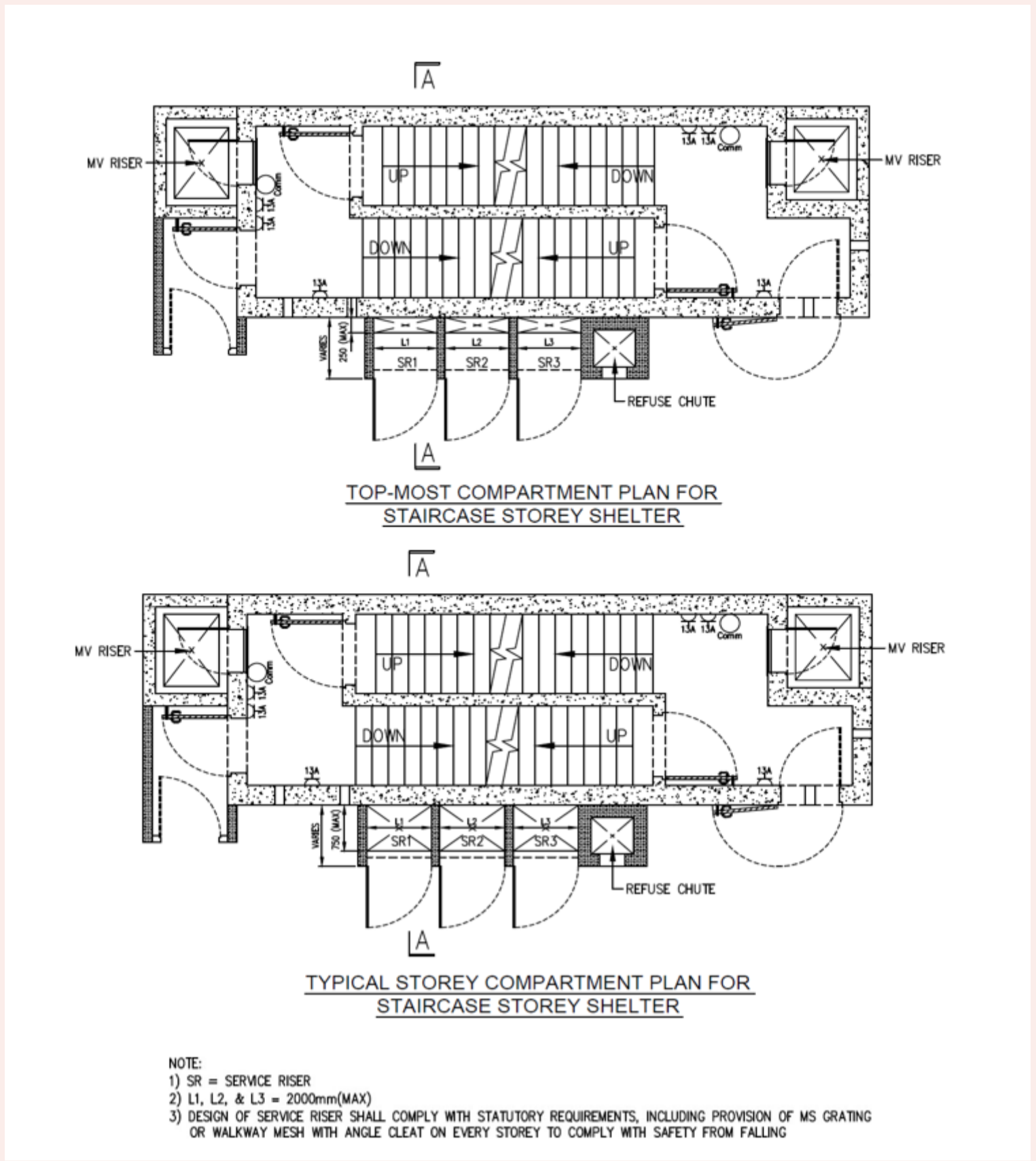
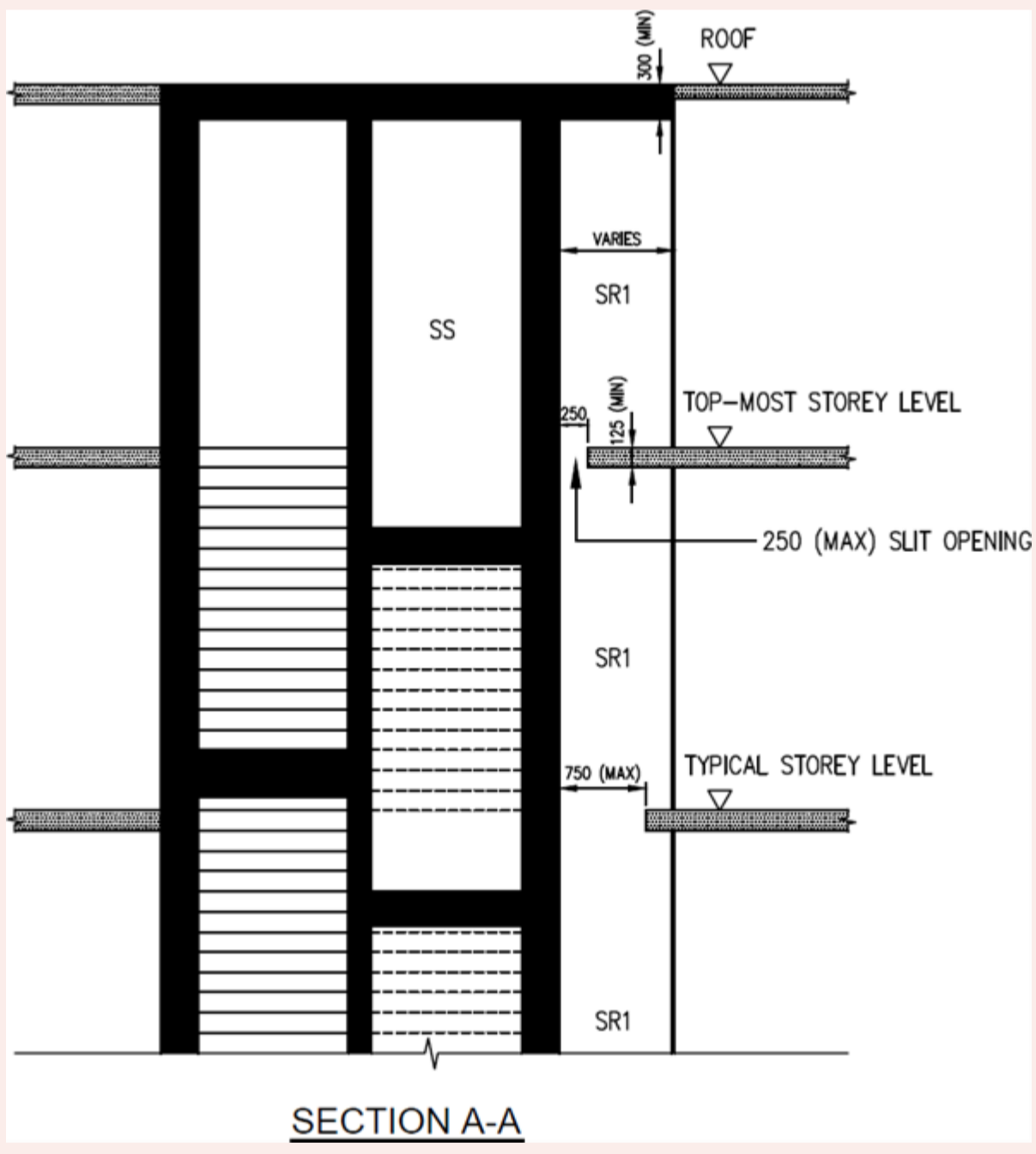

FIGURE 2.4.5(d): SERVICE RISERS ABUTTING S/C SS WALLS



d. For gas riser and any service risers within the setback distance and protrude above the main roof, the design shall comply with the requirements as shown in FIGURE 2.4.5(e) to 2.4.5(g)

Figures & Tables

FIGURE 2.4.5(e): PROTECTION REQUIREMENT AT ROOF LEVEL FOR PROVISION OF GAS AND WATER RISER LOCATED WITHIN SETBACK DISTANCE ENVELOP (TYPE A)

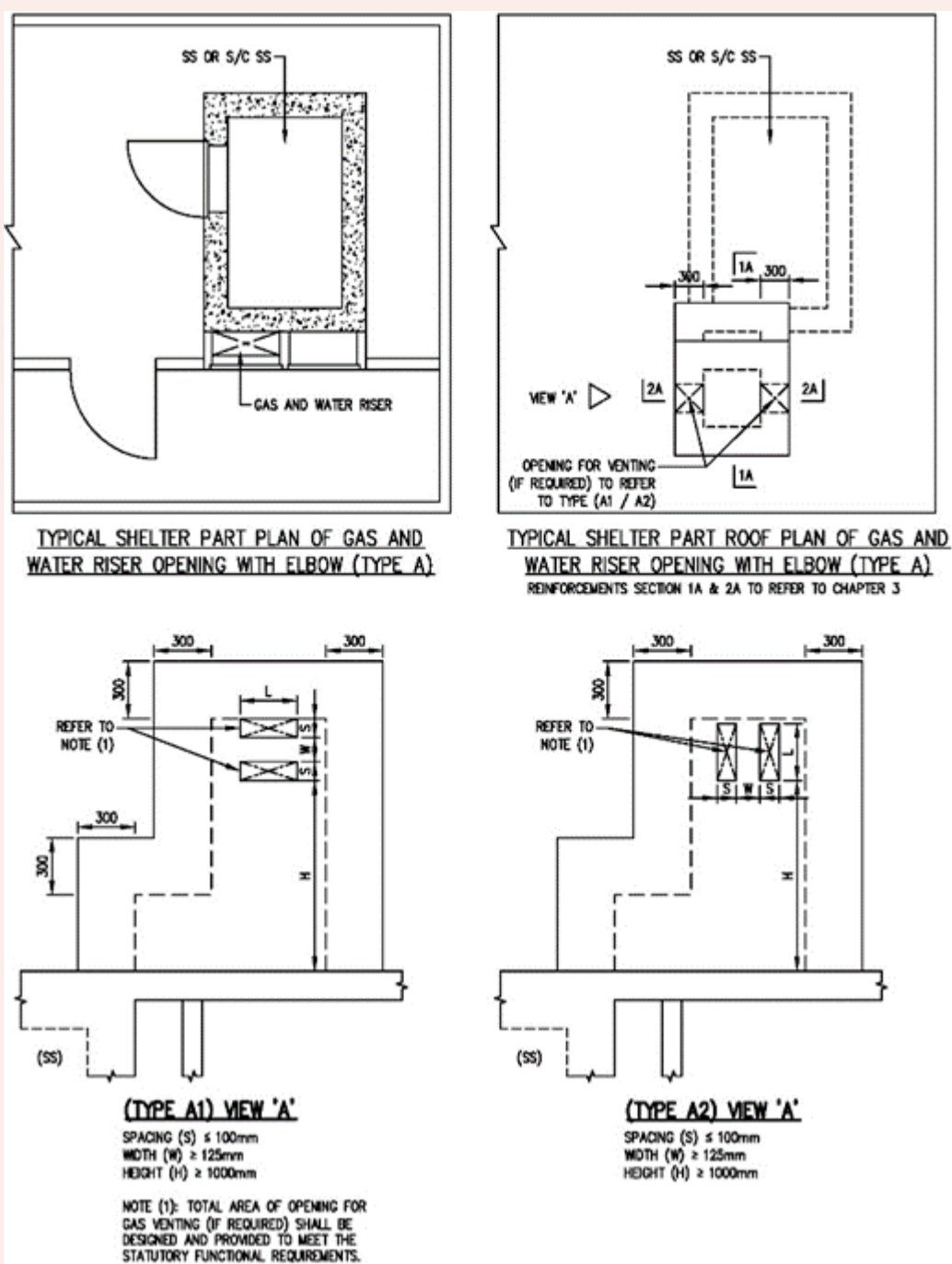

FIGURE 2.4.5(f): PROTECTION REQUIREMENT AT ROOF LEVEL FOR PROVISION OF GAS AND WATER RISER LOCATED WITHIN SETBACK DISTANCE ENVELOP (TYPE B)

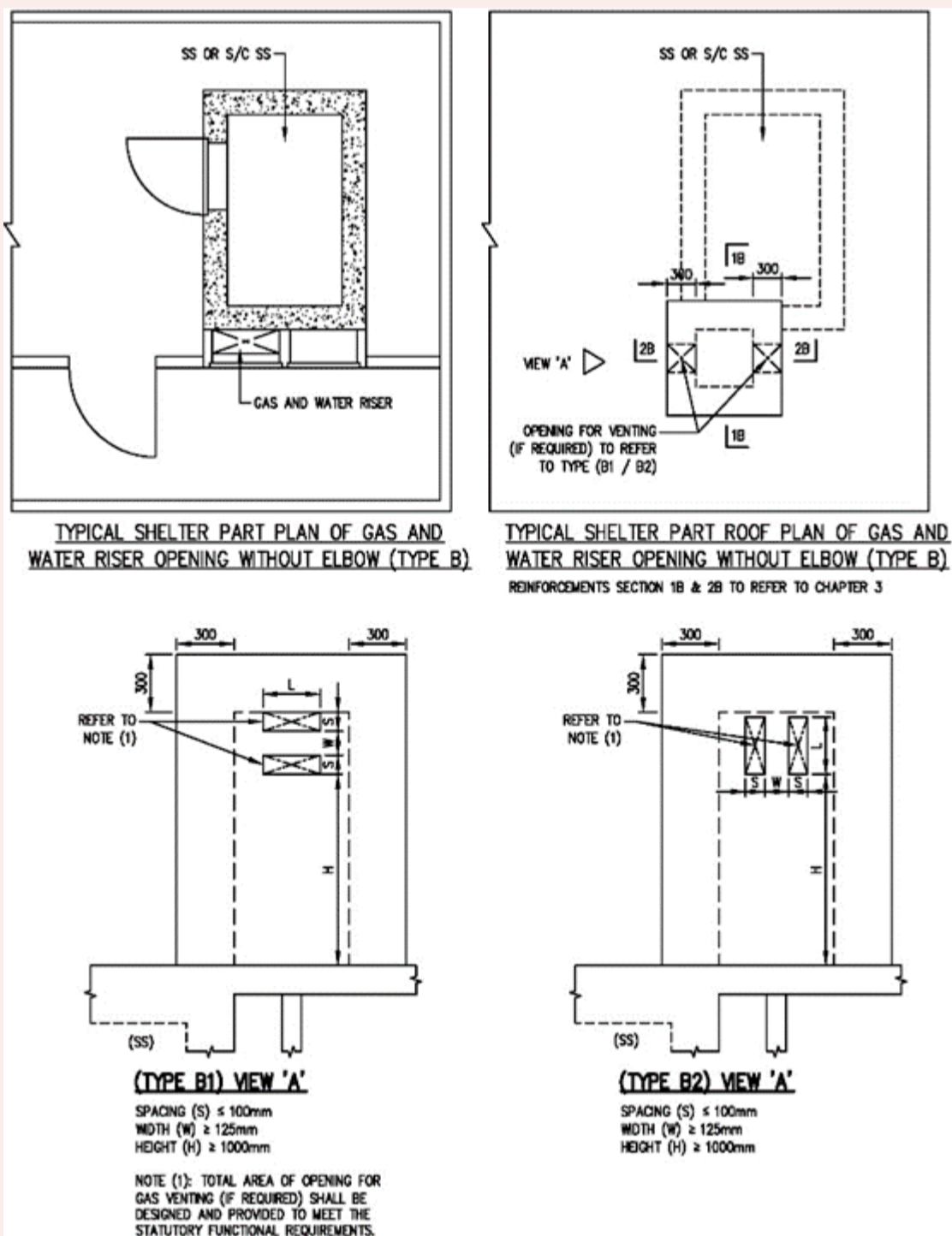
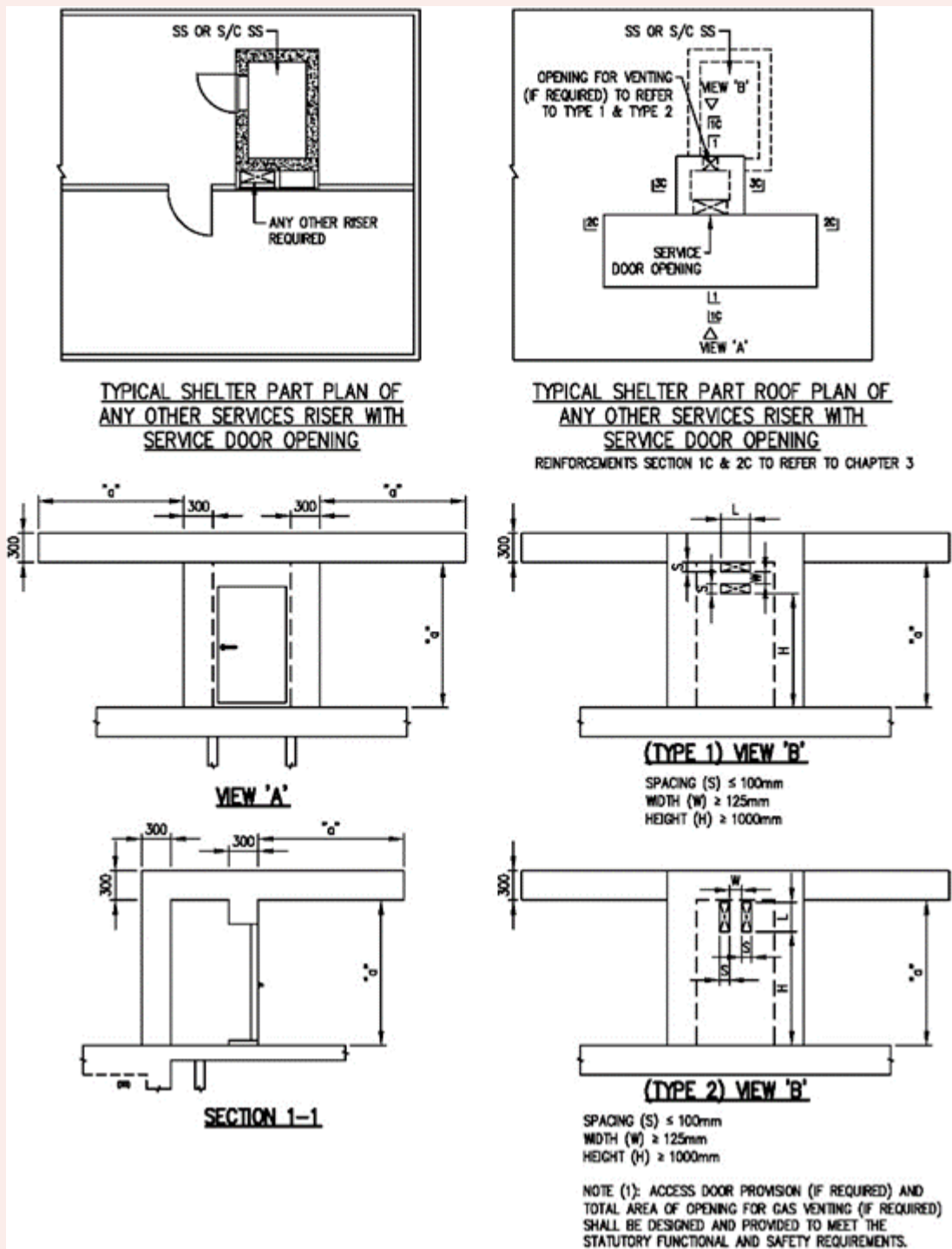

FIGURE 2.4.5(g): PROTECTION REQUIREMENT AT ROOF LEVEL FOR PROVISION OF ANY OTHER SERVICE RISERS WITH SERVICE DOOR OPENING, LOCATED WITHIN SETBACK DISTANCE ENVELOP



e. The gas riser and/or RC refuse chute and any service risers that protrude above the main roof, designed within the setback distance envelope of the SS wall (with door) shall be located away from 45° influence zone from SS door. Refer to FIGURE 2.5.4(e).

Figures & Tables

FIGURE 2.5.4(e): SHIELDING FOR SS DOOR

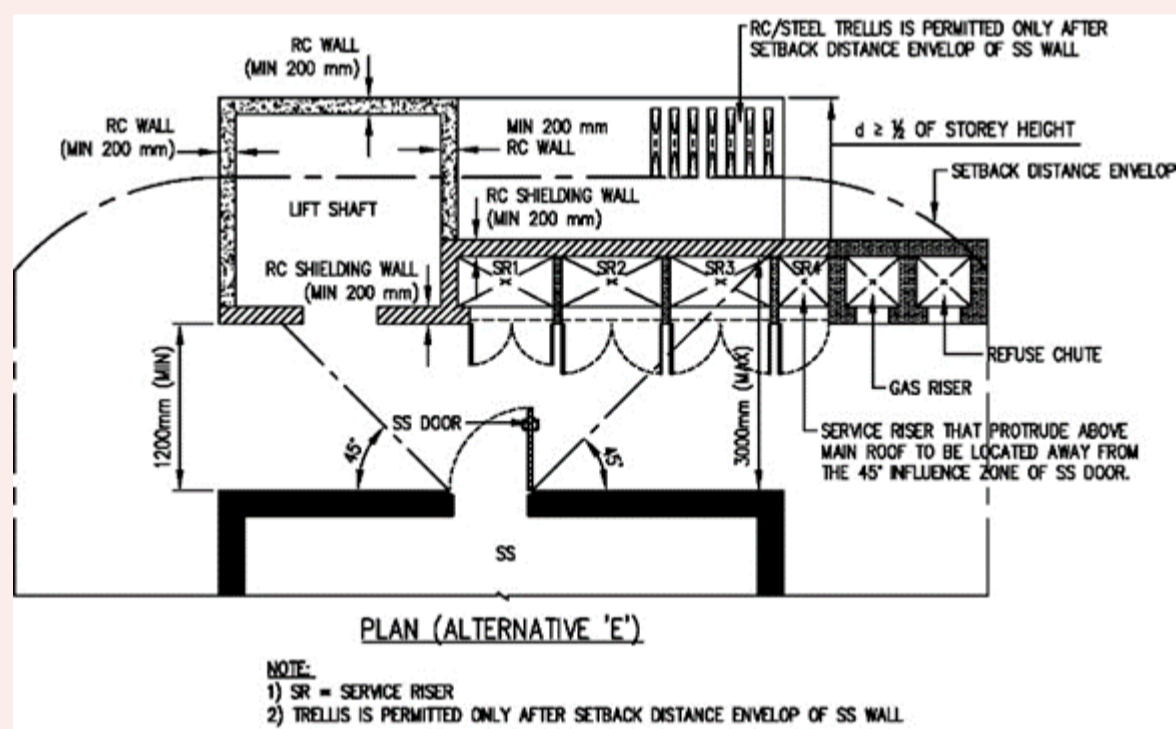

2.4.6 Voids within SS Setback Distances

Voids can be located within the SS setback distance and shall comply with the following requirements. Refer to FIGURE 2.4.6.

Figures & Tables

FIGURE 2.4.6: CONTROL REQUIREMENTS FOR VOIDS

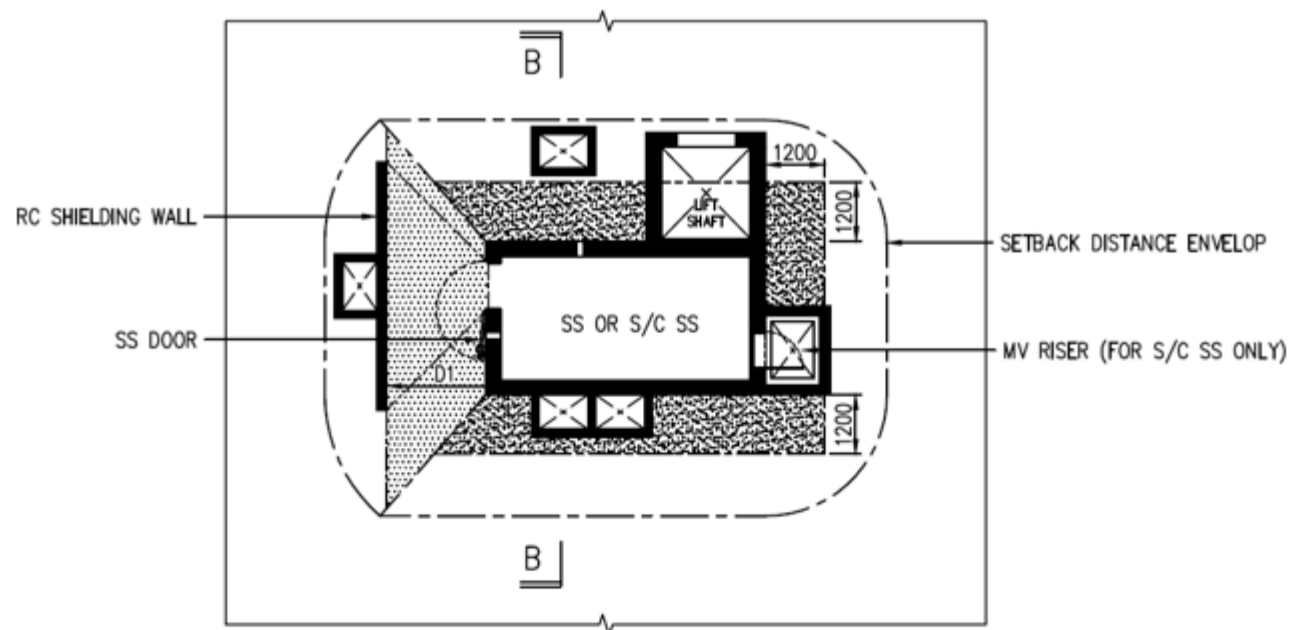

TYPICAL STOREY PLAN

NOTE:

- 1) [Pattern] - 1200mm ZONE
- 2) [Pattern] - NO VOIDS ARE ALLOWED WITHIN THIS SHADED ZONE
- 3) D1 = 1200mm (MIN) AND 3000mm (MAX)
- 4) EBL = EXTERNAL BUILDING LINE
- 5) THE MAXIMUM LENGTH AND AREA OF EACH VOID SHALL BE 1000mm (MAX) AND 0.7m² (MAX)
- 6) VOID LOCATED WITHIN SETBACK DISTANCE FROM SS WALLS (OUTSIDE 45DEG INFLUENCE ZONE OF SS DOOR):
 - i) THERE SHALL BE RC WALL OF AT LEAST 150mm, OR 200mm BLOCK/BRICK WALL.
 - ii) THERE SHALL BE RC WALL OF AT LEAST 150mm, OR 200mm BLOCK/BRICK WALL BETWEEN ADJOINING VOIDS.

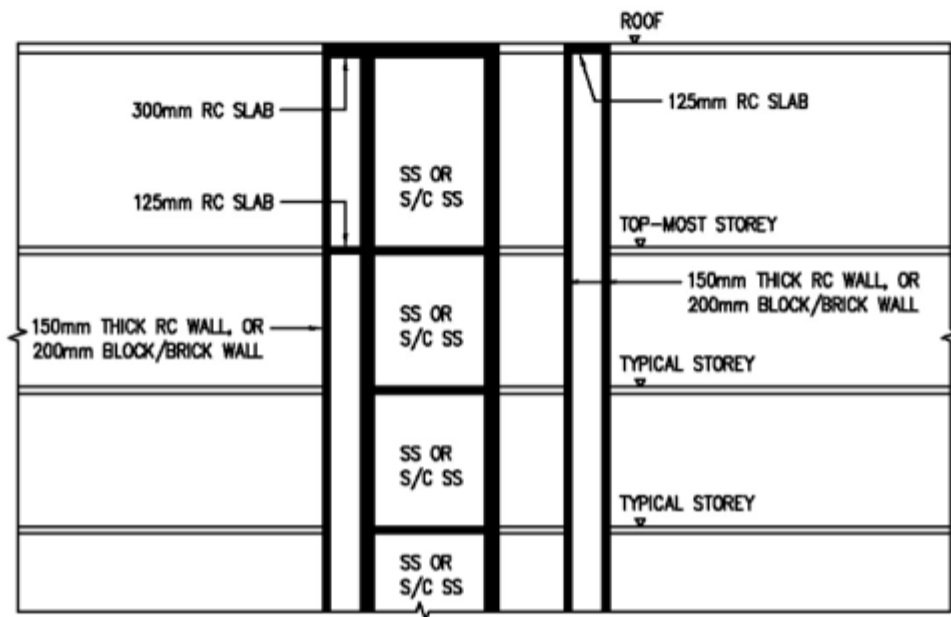

SECTION B-B

- a. Void located within 1200mm boundary from SS walls:
 - i. The void shall be enclosed by minimum thickness of 150mm RC walls or 200mm block/ brick walls.
 - ii. The maximum length and area of each void shall be 1000mm and 0.7m² respectively.
 - iii. There shall be at least a 150mm RC wall or 200mm block/ brick wall between adjoining voids.
 - iv. RC slab of at least 300mm thick shall be provided at the roof of the void.
 - v. RC slab of at least 125mm thick shall be provided to cover the void at the top- most storey level immediately below the roof slab.
- b. Void located beyond 1200mm boundary from SS walls:
 - i. The voids shall be enclosed by minimum thickness of 150mm RC walls or 200mm block/ brick walls.
 - ii. The maximum length and area of each void shall be 1000mm and 0.7m² respectively.
 - iii. There shall be at least a 150mm RC wall or 200mm block/ brick wall between adjoining voids.
 - iv. RC slab of at least 125mm thick shall be provided at the roof of the void.

CLAUSE 2.5 SS DOOR

2.5.1 Opening Dimensions

The opening dimensions of SS door shall be:

- a. For SS – 900(W) mm x 1900(H) mm
- b. For S/C SS and scissor S/C SS
 - i. For entrance SS door, the dimension shall be 900(W) mm or 1000(W) mm x 2055(H) mm.
 - ii. For internal SS door at mid-landing or main landing in the staircase, the dimension shall be 1000(W) mm x 2055(H) mm.
- c. SS door frame that is cast together with the SS wall shall have single or double door rebate. Refer to FIGURE 2.5.1(a) and 2.5.1(b).

Figures & Tables

FIGURE 2.5.1(a): SS DOOR FRAME WITH SINGLE DOOR REBATE

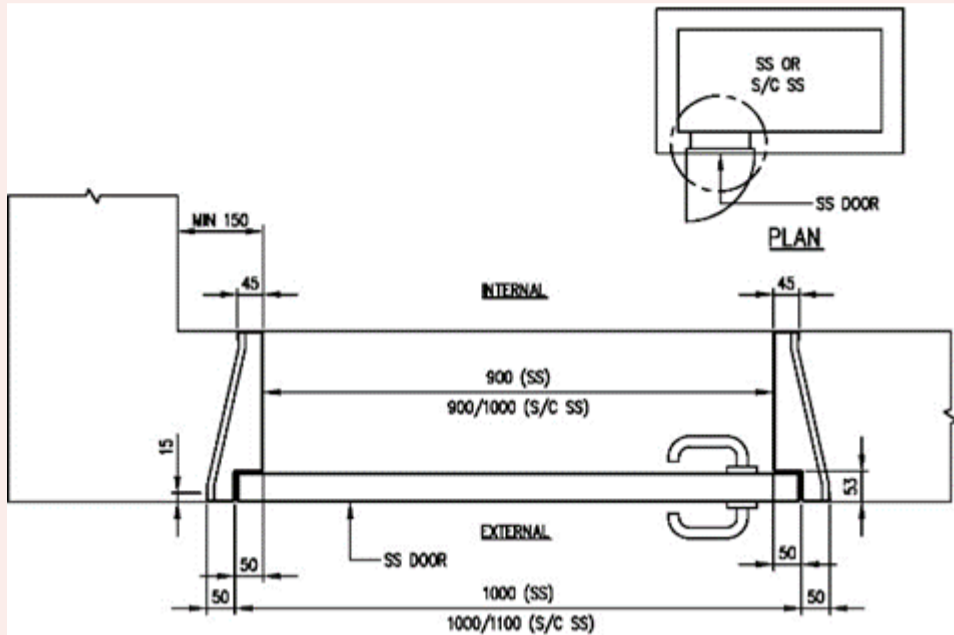
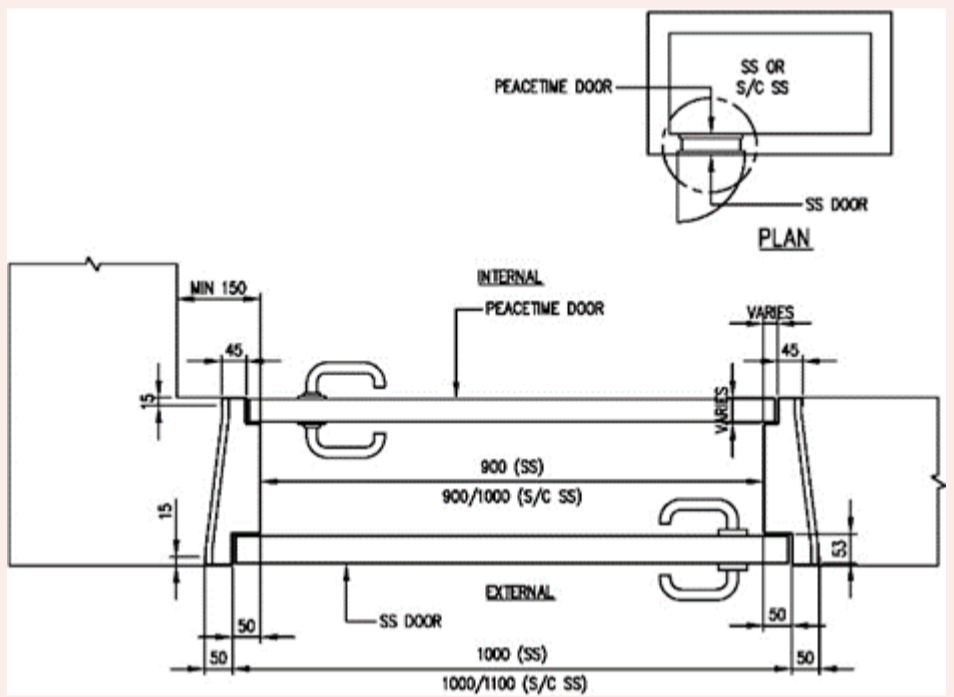

FIGURE 2.5.1(b): SS DOOR FRAME WITH DOUBLE DOOR REBATES



2.5.2 Location

The SS door shall be located in a SS wall with a minimum setback distance of 3000mm and shall not swing in a direction that will clash with the swing path of another peacetime door. Refer to FIGURE 2.5.2.

Figures & Tables

FIGURE 2.5.2: STAIRCASE SS COMPARTMENT WITH CLEAR DOOR SWING ZONE OF FIRE DOOR AND INTERNAL OR EXTERNAL SS DOOR OPENING IN SAME LOCATION

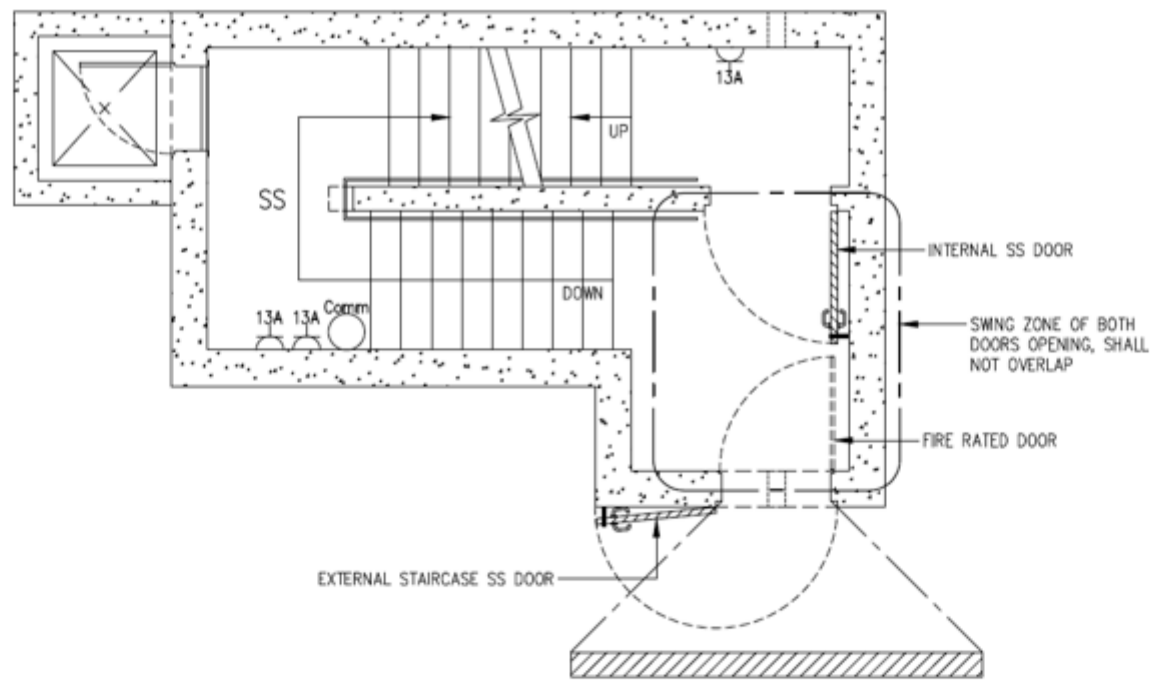

PLAN OF STAIRCASE SS COMPARTMENT AT TYPICAL FLOOR

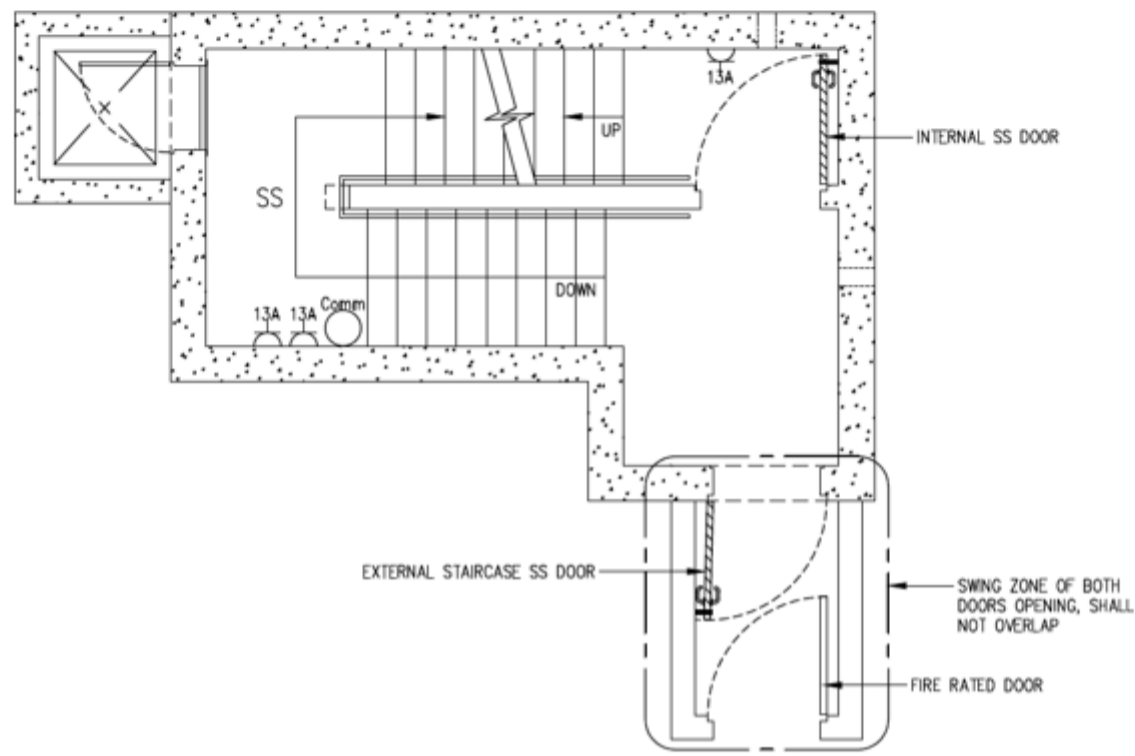

2.5.3 Door Frame

- a. There shall be a minimum 150mm reinforced concrete wall segment next to vertical edge of SS or S/C SS door frame. Refer to FIGURE 2.5.3(a) and 2.5.3(c).

Figures & Tables

FIGURE 2.5.3(a): CONCRETE WALL SEGMENT AT SS DOOR

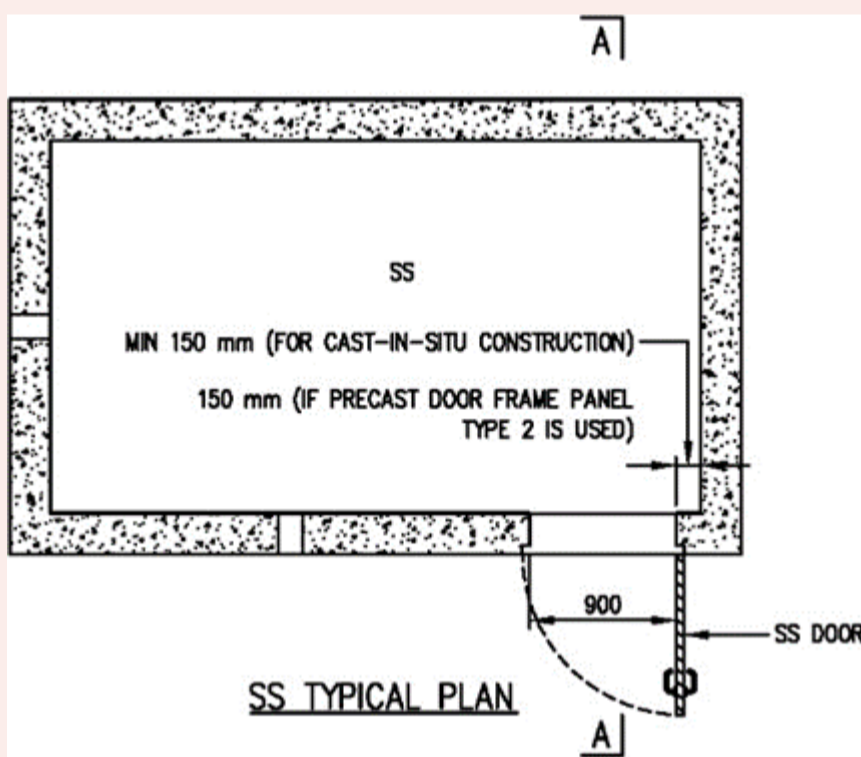
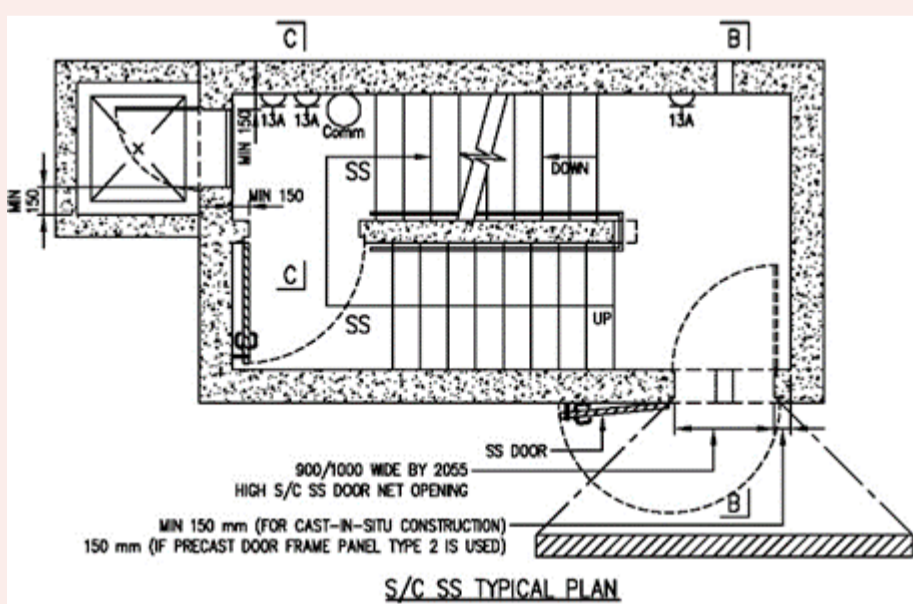

FIGURE 2.5.3(c): CONCRETE WALL SEGMENT AT S/C SS DOORS AND BLAST HATCH



- b. For pre-cast door frame panel of Type 1, the reinforced concrete next to two vertical edges of the SS door frame shall be 300mm each. Refer to FIGURE 3.5.5(a).

Figures & Tables

FIGURE 3.5.5(a): PLAN OF SS WALLS WITH PRECAST SS DOOR FRAME PANEL (TYPE 1)

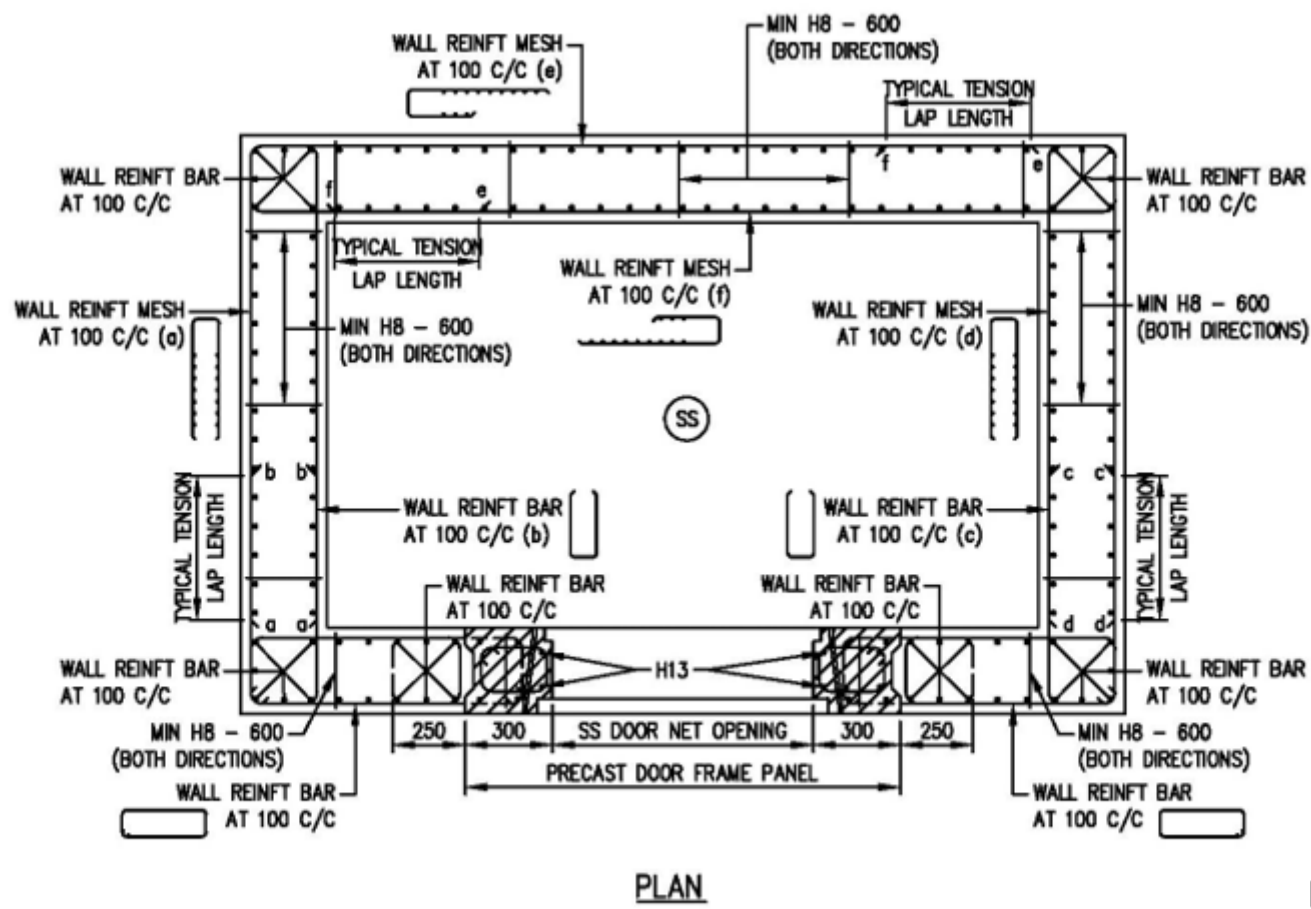

c. For pre-cast door frame panel of Type 2, the reinforced concrete next to vertical edges of the SS door frame shall be 300mm on one side, and 150mm plus the SS wall thickness on the other side. Refer to FIGURE 3.5.5(f).

Figures & Tables

FIGURE 3.5.5(f): PLAN OF SS WALLS WITH PRECAST SS DOOR FRAME PANEL (TYPE 2)

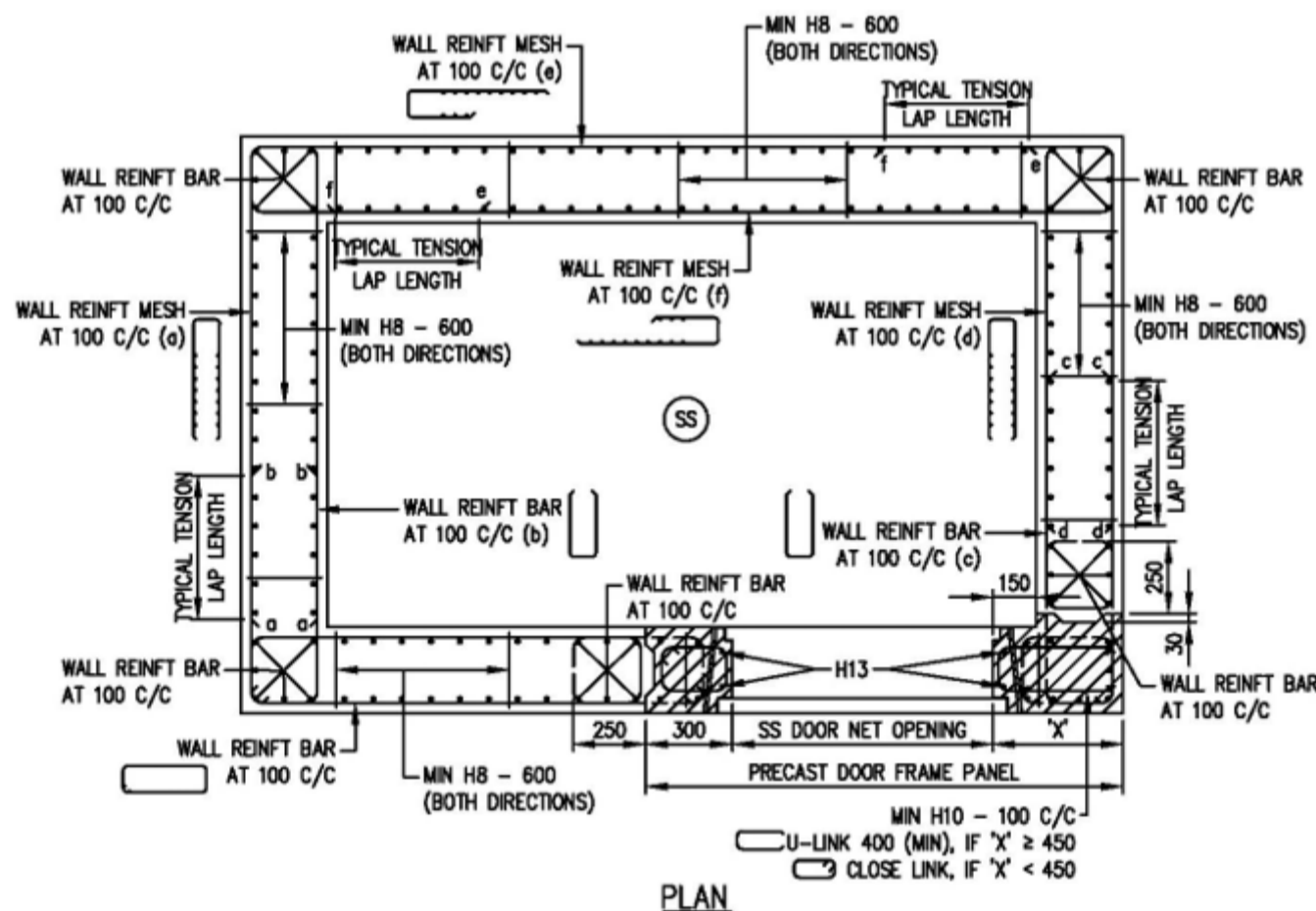

d. For pre-cast door frame panel of Type 3, the reinforced concrete panel with full length or width of SS wall must be properly connected to the in-situ SS walls and slabs. Refer to FIGURE 3.5.5(k).

Figures & Tables

FIGURE 3.5.5(k) PLAN OF SS WALLS WITH PRECAST SS DOOR FRAME PANEL (TYPE 3)

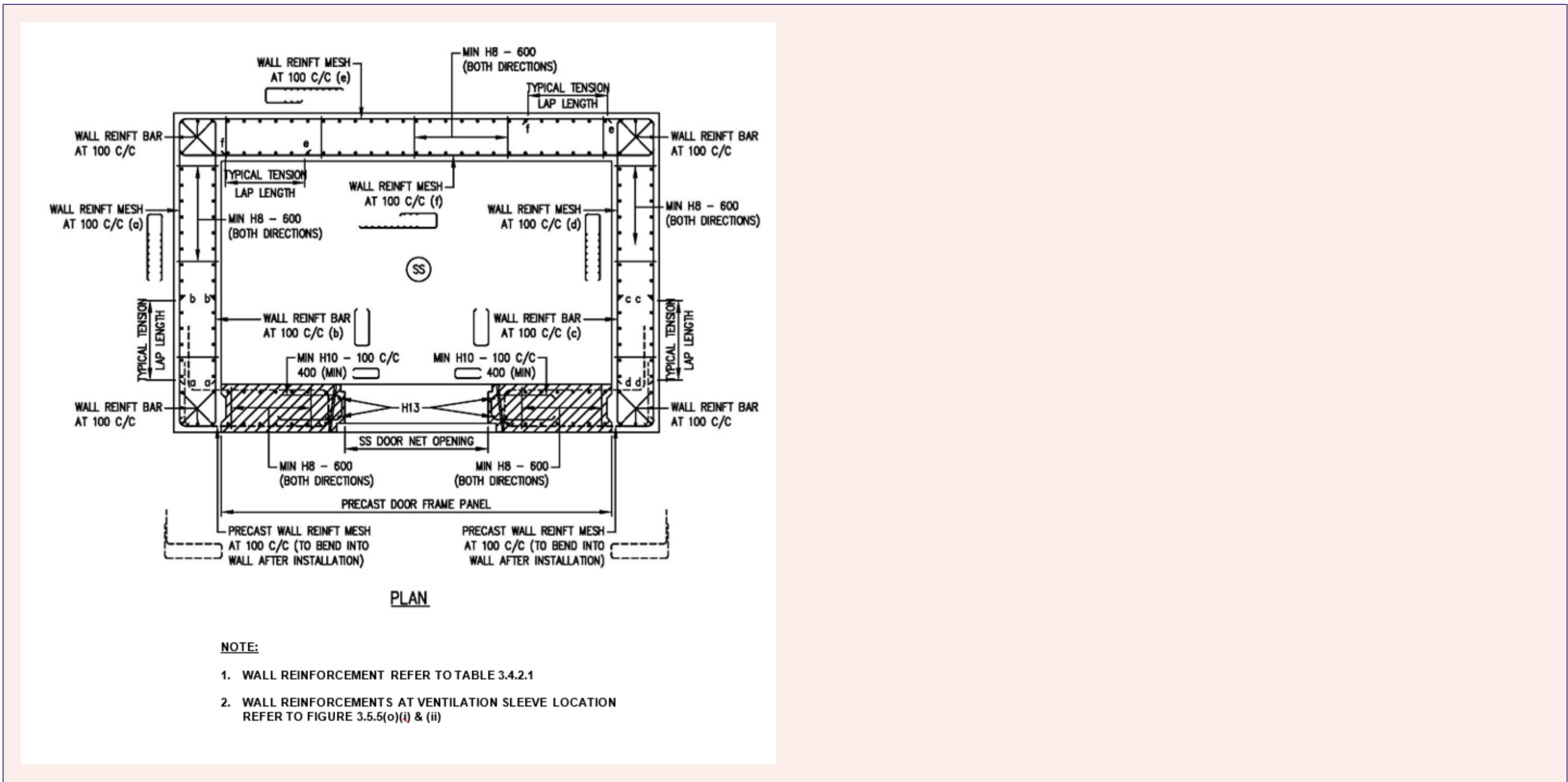

e. The SS or S/C SS door frame must be positioned such that its door is above FFL and can be opened at least 90°. Refer to FIGURE 2.5.3(b) and 2.5.3(d).

Figures & Tables

FIGURE 2.5.3(b): SS DOOR KERB

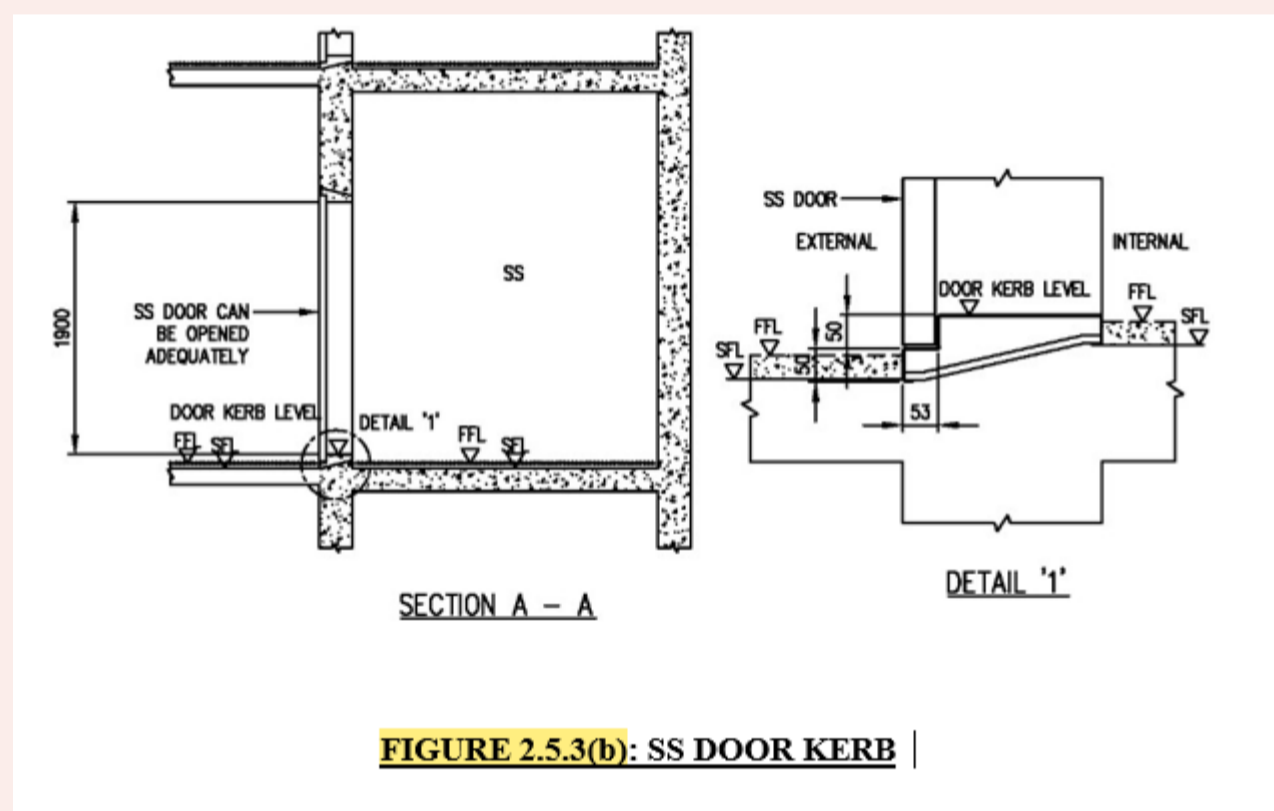
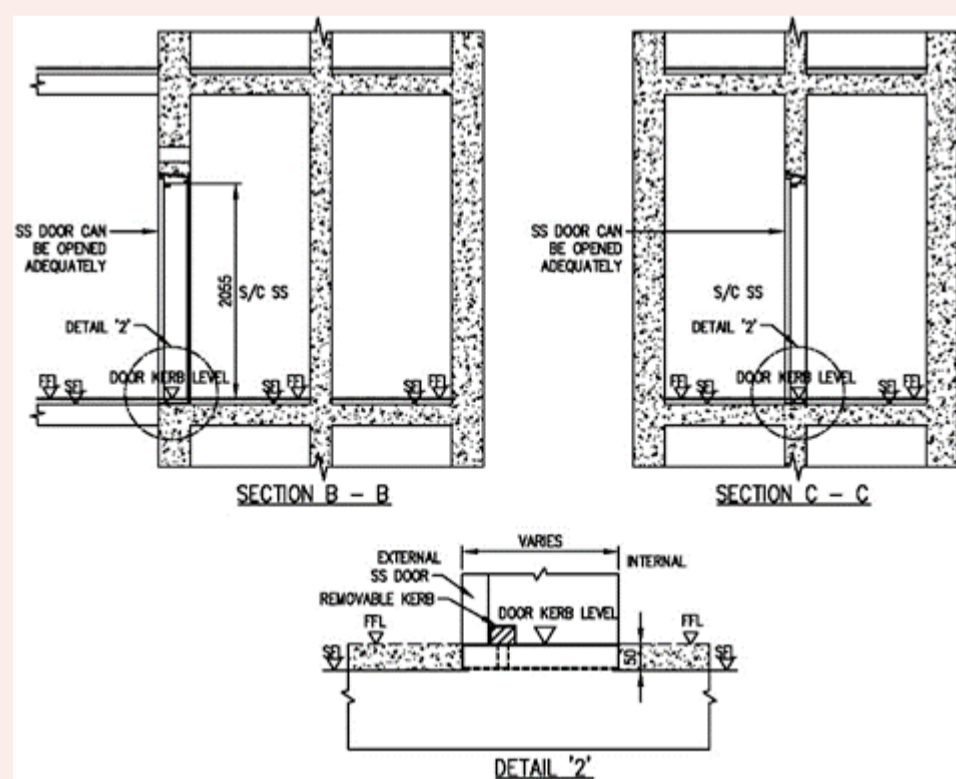

FIGURE 2.5.3(d): S/C SS DOOR KERB



2.5.4 Shielding Wall

- A full-height reinforced concrete shielding wall, with a minimum thickness of 200mm (with protective slab extended by at least 1/2 of storey height from the shielding wall) or 300mm (if the protective slab is extended by less than 1/2 of storey height), has to be provided in front of the entrance SS door.
- The shielding wall to the SS door can be positioned and arranged in the following manner:
 - A shielding wall has to be positioned such that it is at least 1200mm but not more than 3000mm from the SS door and is within influence zone of 45-degree from the SS door. Refer to FIGURE 2.5.4(a) to 2.5.4(f). The shielding wall forming part of the dwelling unit's wall shall be clearly indicated on plans.

Figures & Tables

FIGURE 2.5.4(a) to 2.5.4(f)

FIGURE 2.5.4(a): SHIELDING FOR SS DOOR

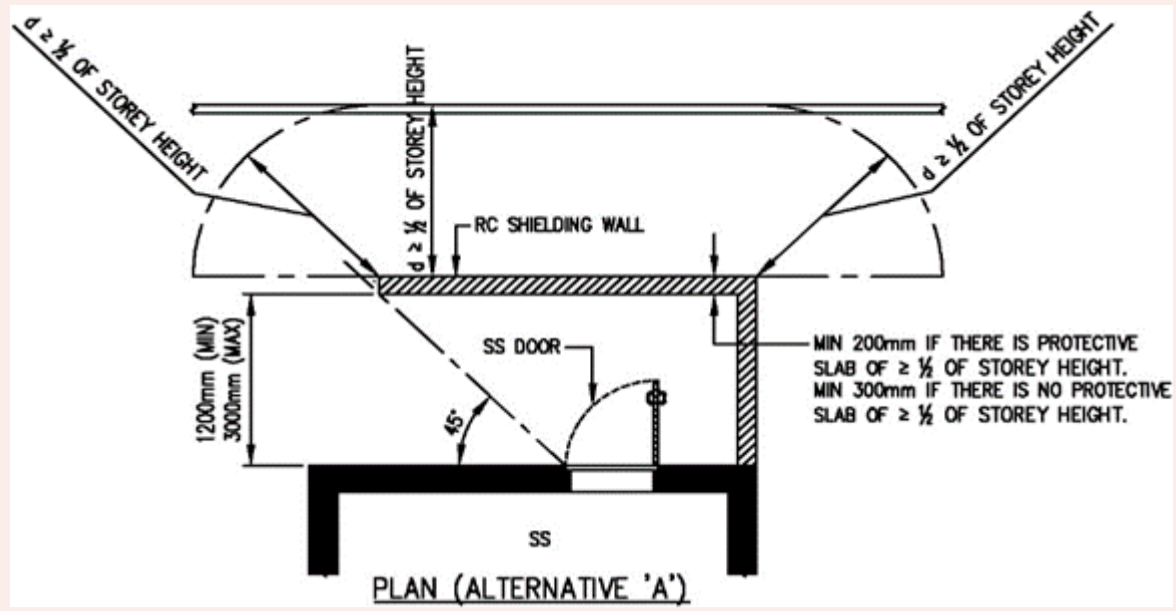

FIGURE 2.5.4(b): SHIELDING FOR SS DOOR

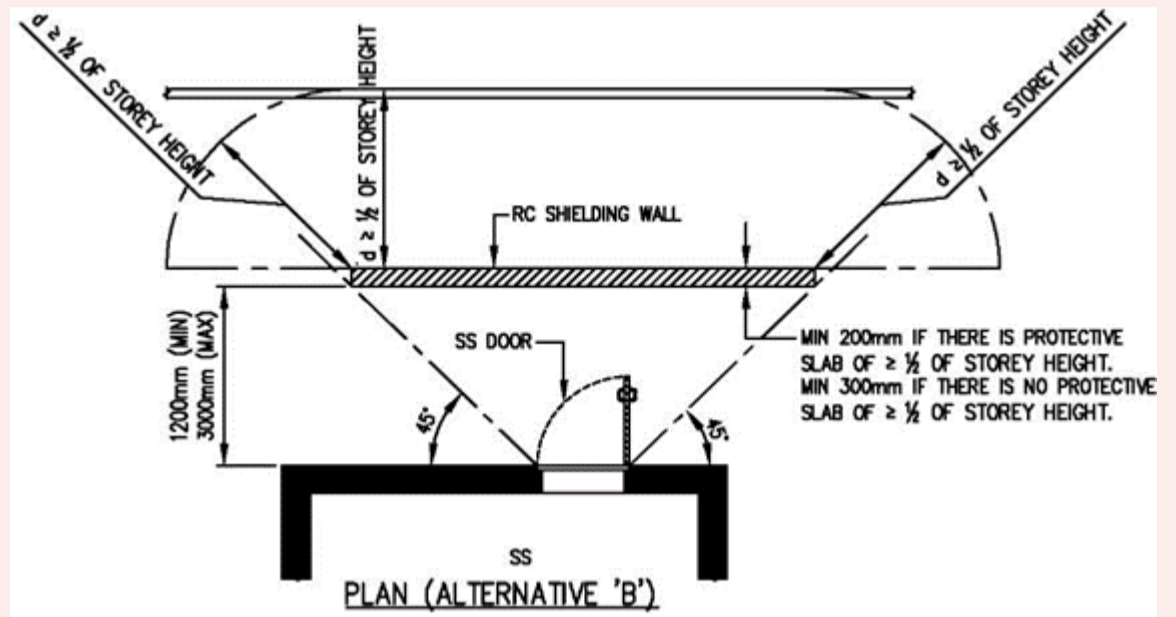

FIGURE 2.5.4(c): SHIELDING FOR SS DOOR

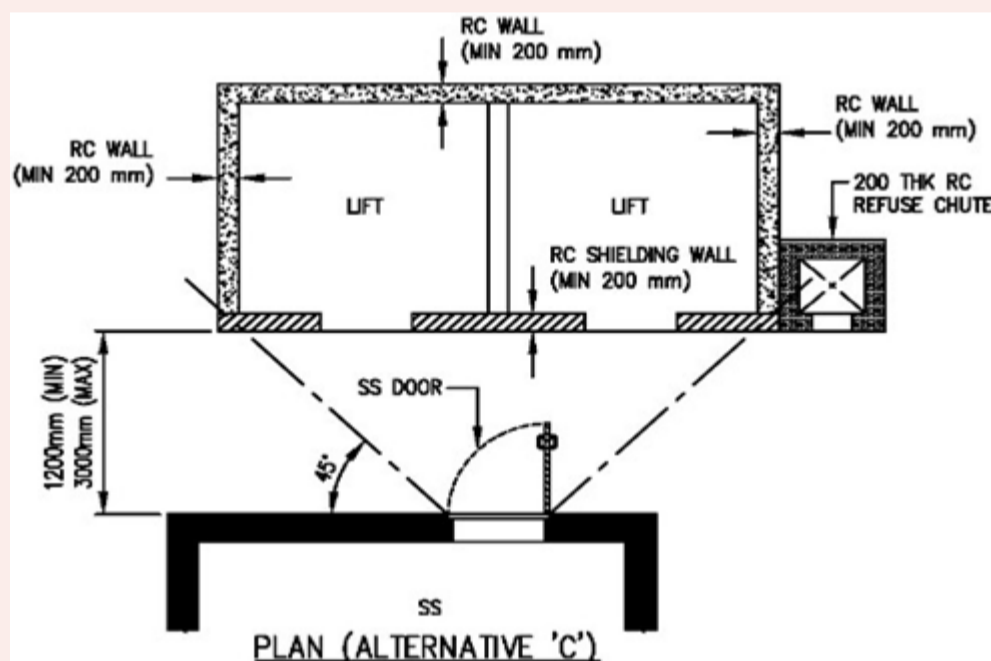

FIGURE 2.5.4(d): SHIELDING FOR SS DOOR

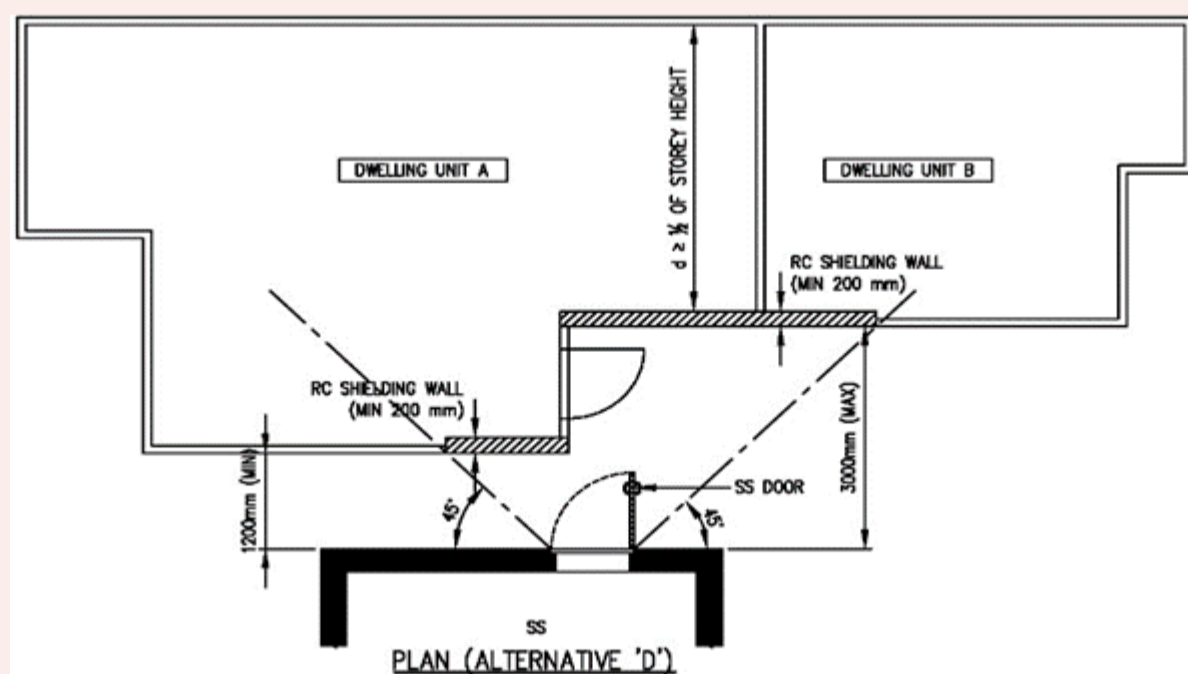

FIGURE 2.5.4(e): SHIELDING FOR SS DOOR

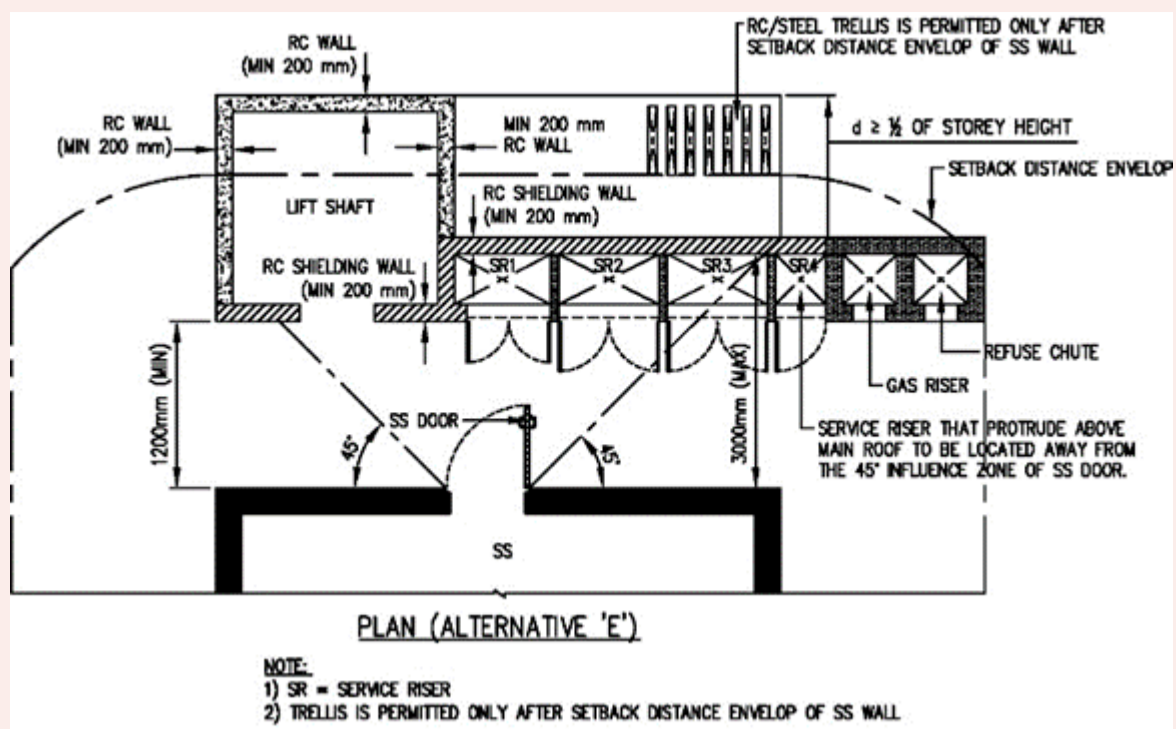
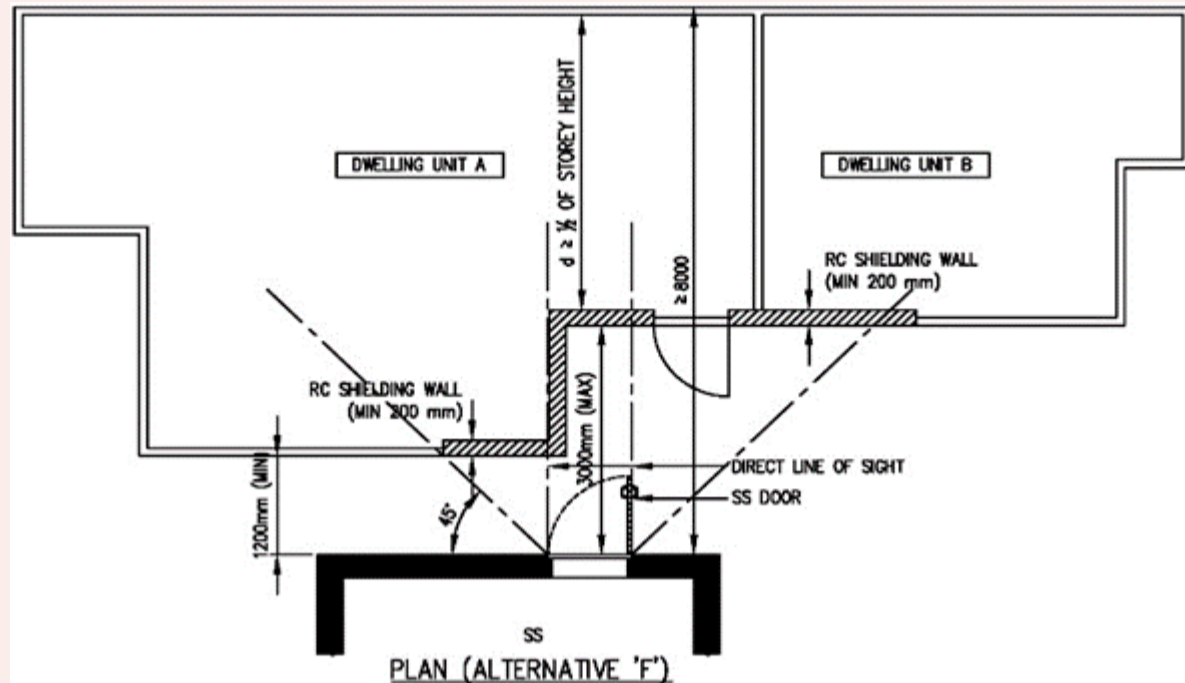

FIGURE 2.5.4(f): SHIELDING FOR SS DOOR



ii. The shielding wall shall be protected by floor slab or trellis of at least half the storey height measured from the shielding wall. Refer to FIGURE 2.5.4(a), 2.5.4(b), 2.5.4(d) to 2.5.4(f).

Figures & Tables

FIGURE 2.5.4(a) to 2.5.4(f)

FIGURE 2.5.4(a): SHIELDING FOR SS DOOR

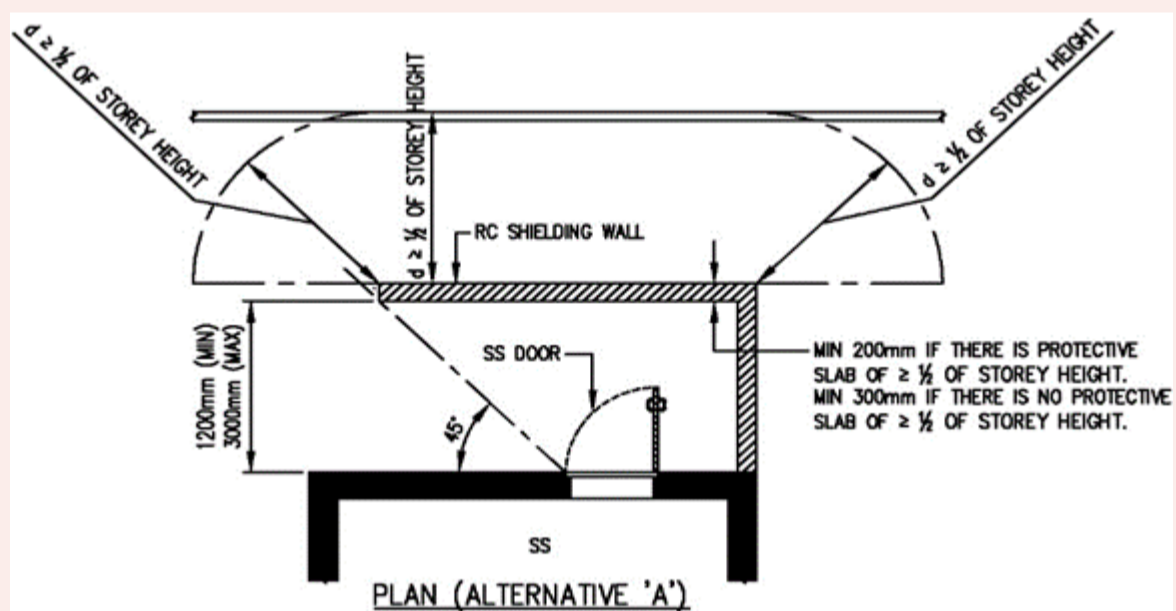

FIGURE 2.5.4(b): SHIELDING FOR SS DOOR

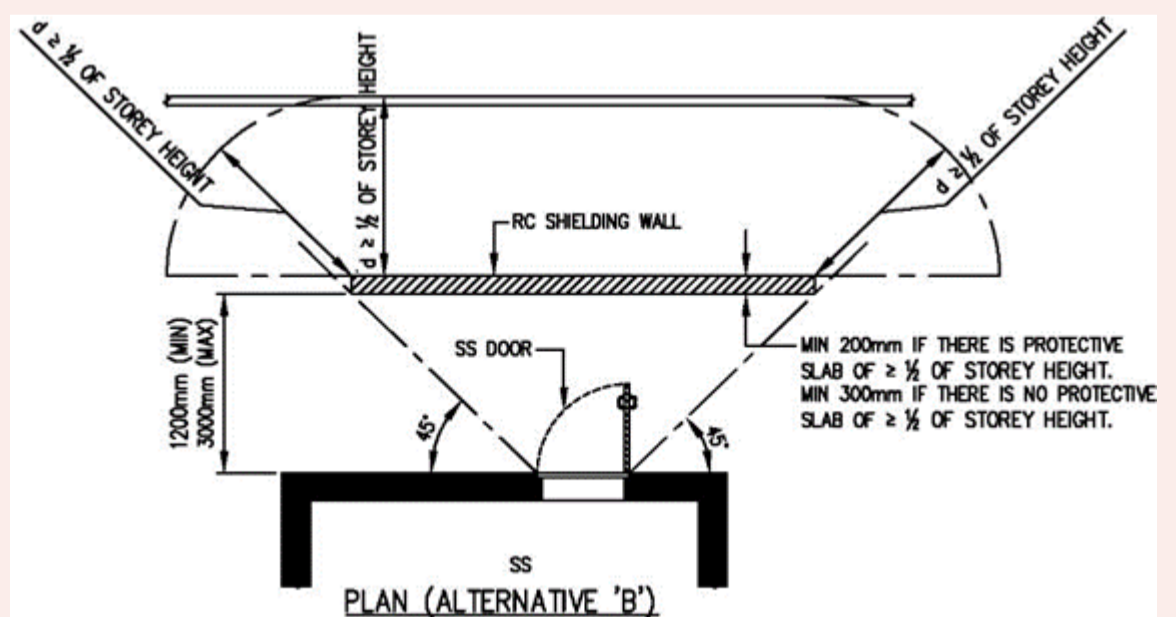

FIGURE 2.5.4(c): SHIELDING FOR SS DOOR

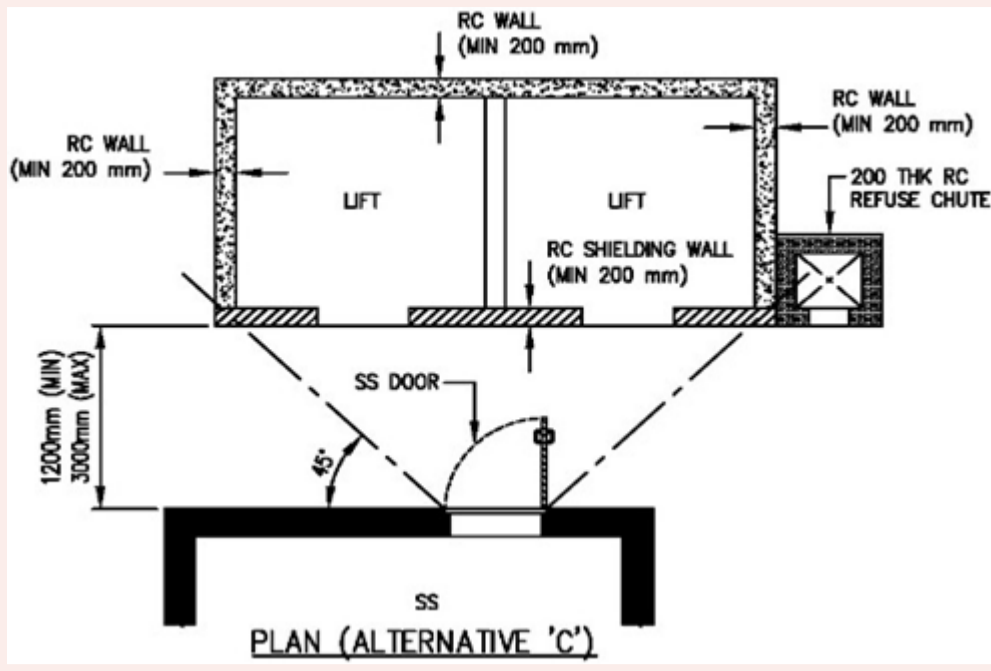

FIGURE 2.5.4(d): SHIELDING FOR SS DOOR

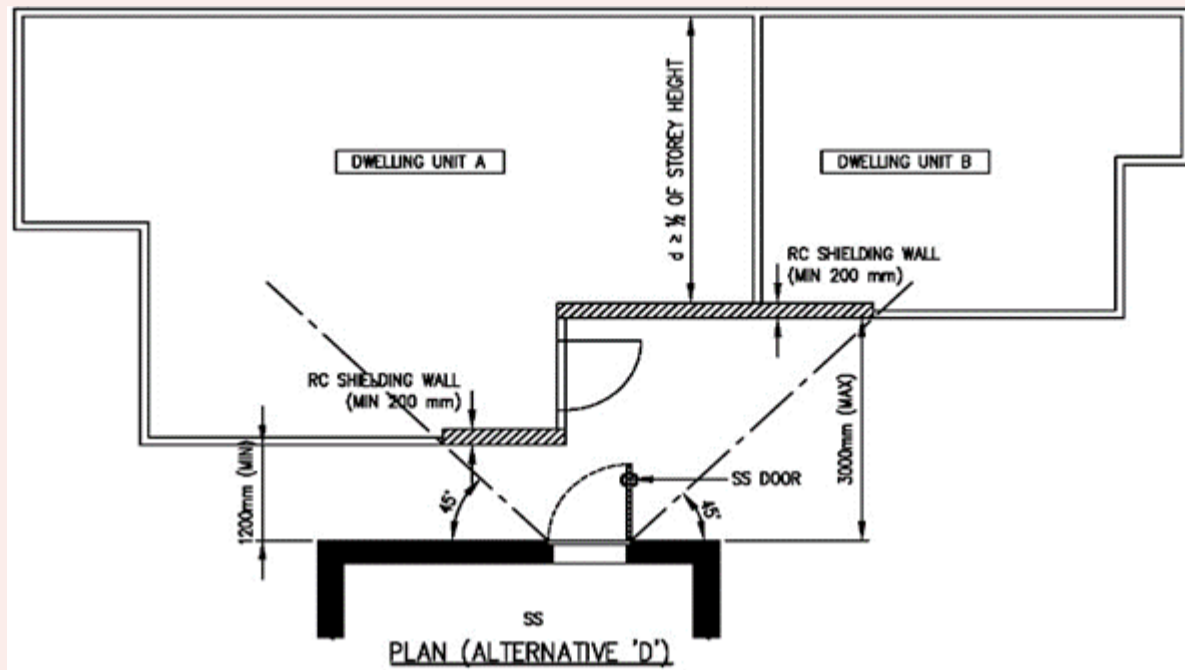

FIGURE 2.5.4(e): SHIELDING FOR SS DOOR

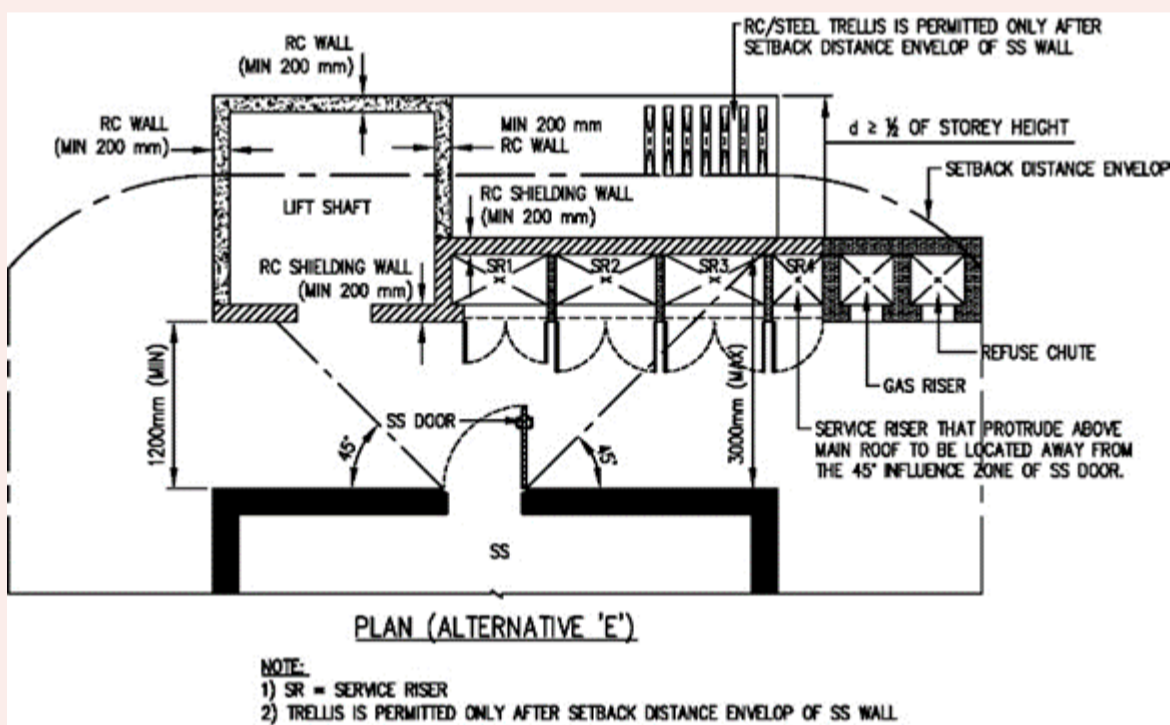
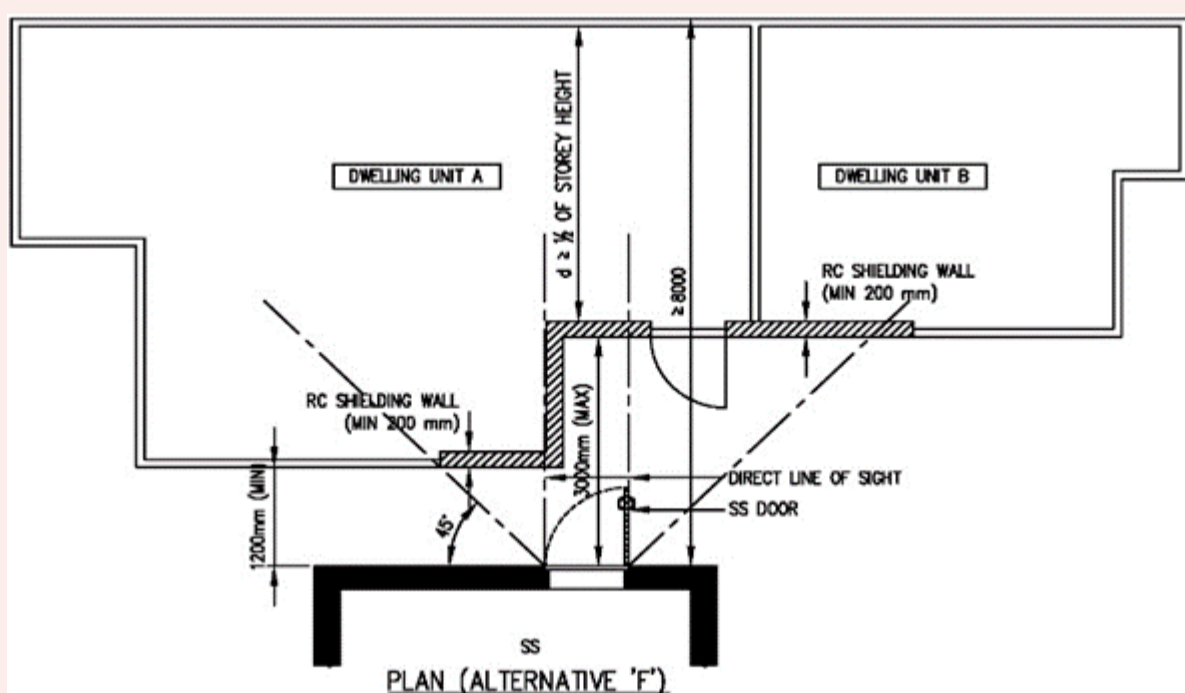

FIGURE 2.5.4(f): SHIELDING FOR SS DOOR



iii. Where the lift shaft is facing the SS door, the RC wall of the shaft can be used as a shielding wall provided its thickness is at least 200mm. Refer to FIGURE 2.5.4(c). For such case, the surrounding lift shaft wall and roof slab of lift motor room shall be reinforced concrete.

Figures & Tables

FIGURE 2.5.4(c): SHIELDING FOR SS DOOR

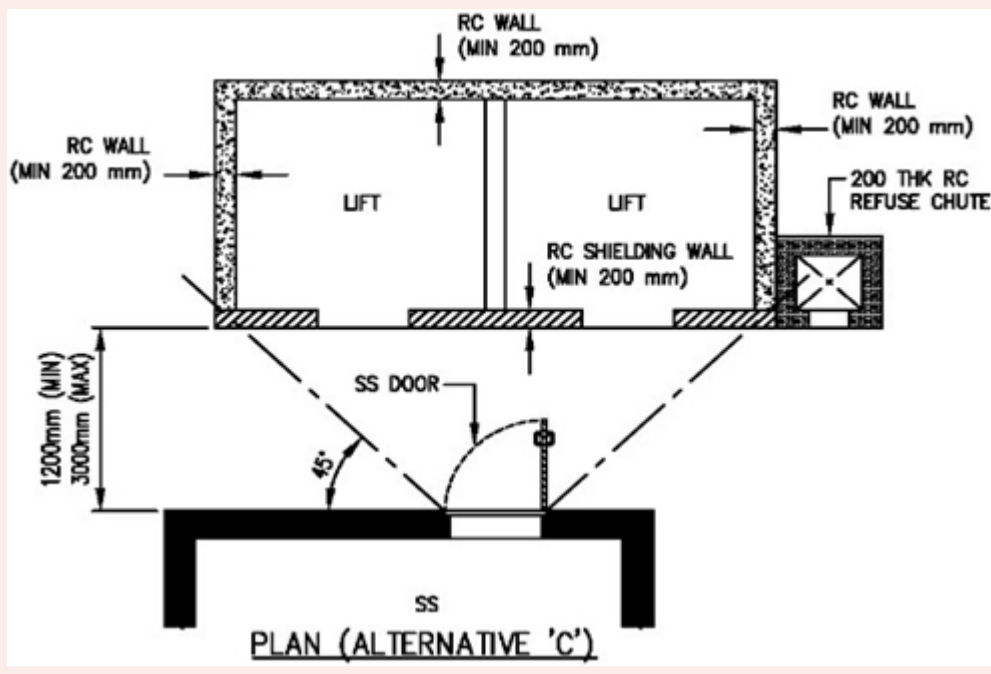

iv. For service risers located within influence zone, the RC walls of the risers can be used as shielding wall provided its thickness is at least 200mm. Refer to FIGURE 2.5.4(e).

Figures & Tables

FIGURE 2.5.4(e): SHIELDING FOR SS DOOR

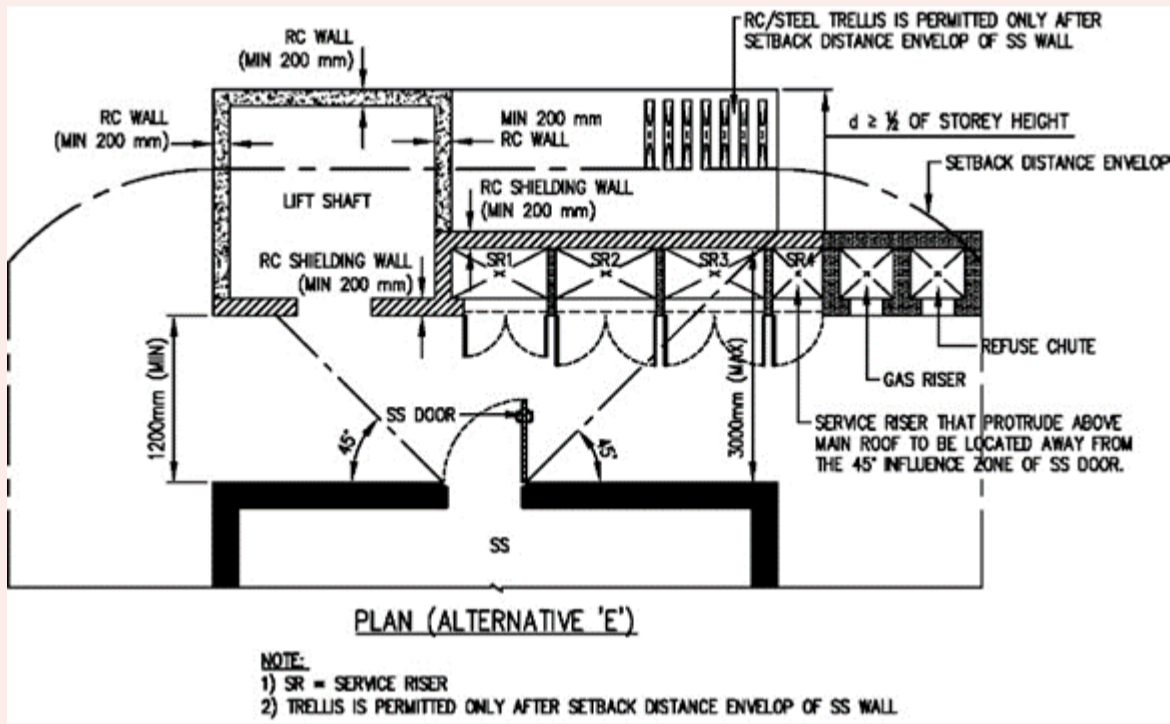

v. Where the shielding wall located within influence zone is discontinuous, the opening in this wall shall not be in the line of sight of SS door. In the case of the opening not in the line of sight of SS door but facing the SS wall, there shall be RC slabs with a minimum distance of 8000mm provided from the SS wall. Refer to FIGURE 2.5.4(d) and 2.5.4(f).

Figures & Tables

FIGURE 2.5.4(d): SHIELDING FOR SS DOOR

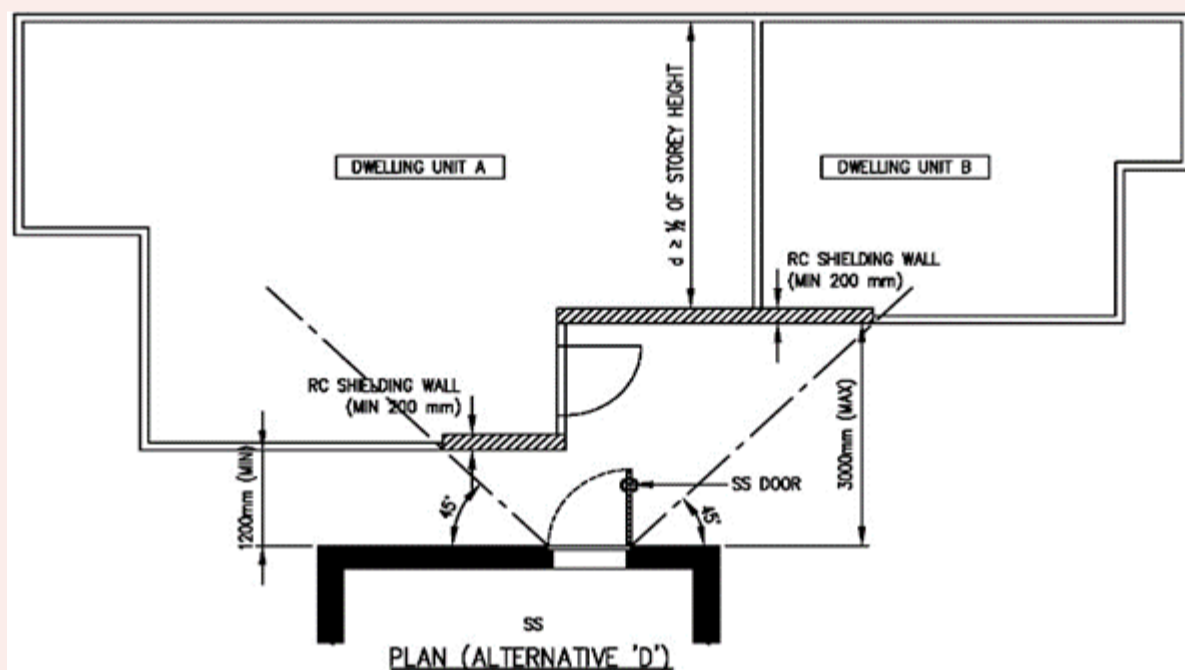
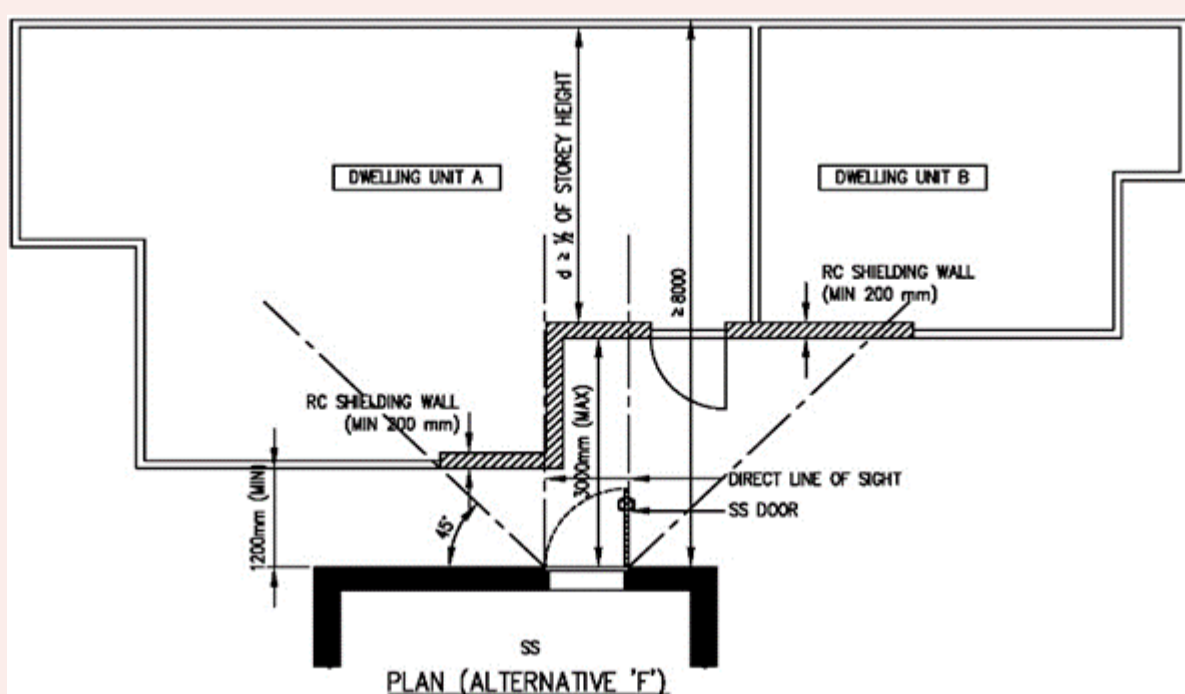

FIGURE 2.5.4(f): SHIELDING FOR SS DOOR



2.5.5 Strengthened Ceiling Slab outside SS Door

The minimum thickness of the reinforced concrete ceiling slab immediately outside the SS door shall be 150mm and structurally connected to SS tower. The dimensions of this strengthened portion shall be as shown in FIGURE 2.5.5.

Figures & Tables

FIGURE 2.5.5: REQUIREMENTS FOR STRENGTHENING CEILING SLAB IN FRONT OF SS DOOR

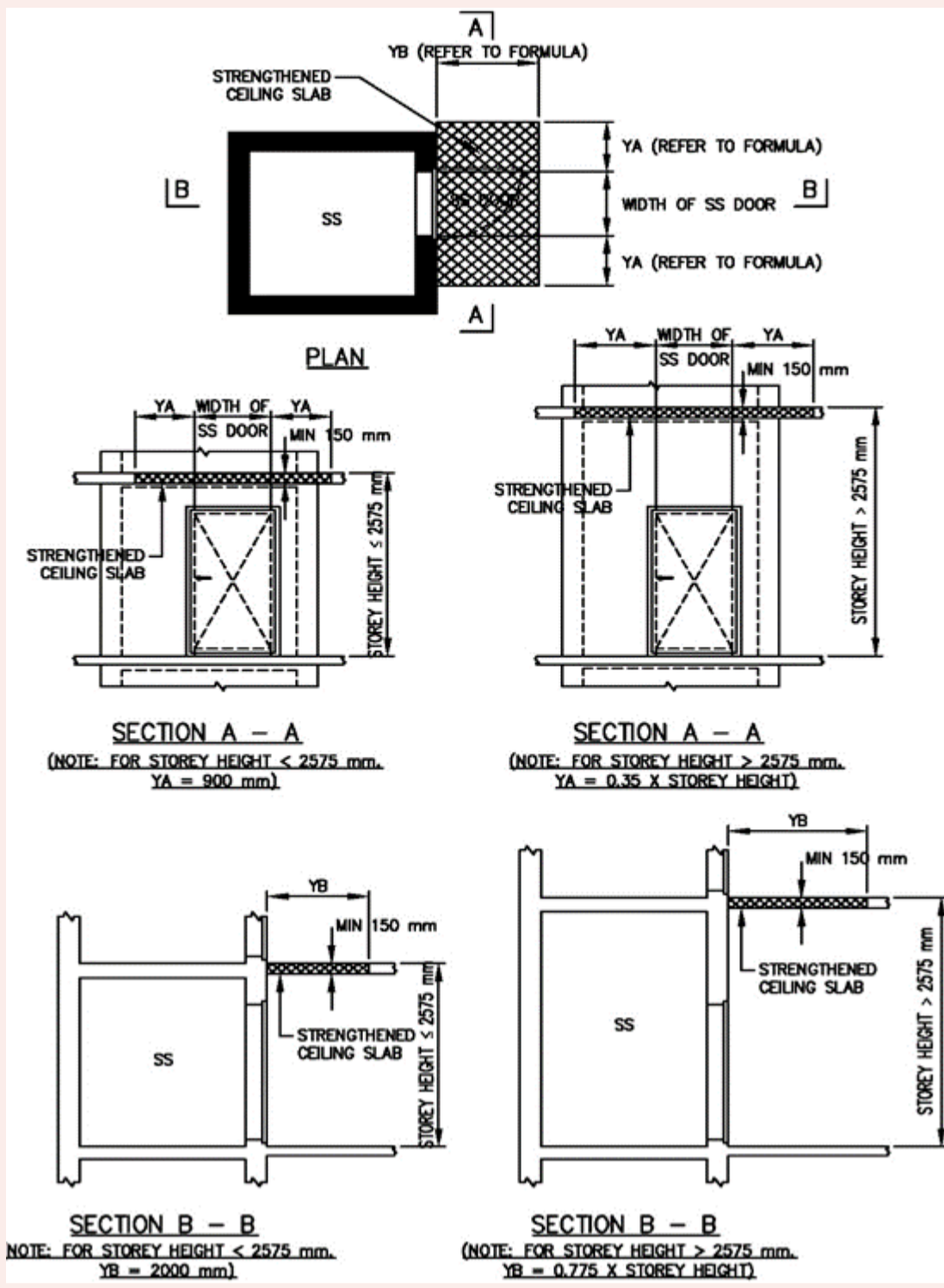

CLAUSE 2.6 FIXTURES IN SS

2.6.1 General

a. The following electrical and communication fixtures (Refer to FIGURE 2.6.1(a), 2.6.1(b), 2.12.1(f) and 2.12.2(j)) in steel or PVC conduit system shall be provided inside each SS or S/C SS compartment to provide adequate stay-in and/or communication facilities:

- i. 13A switch socket outlets;
- ii. Switch and lighting points;
- iii. Communication line for telephony outlet.

Figures & Tables

FIGURE 2.6.1(a): SPECIFIC SS FIXTURE AND OPENINGS

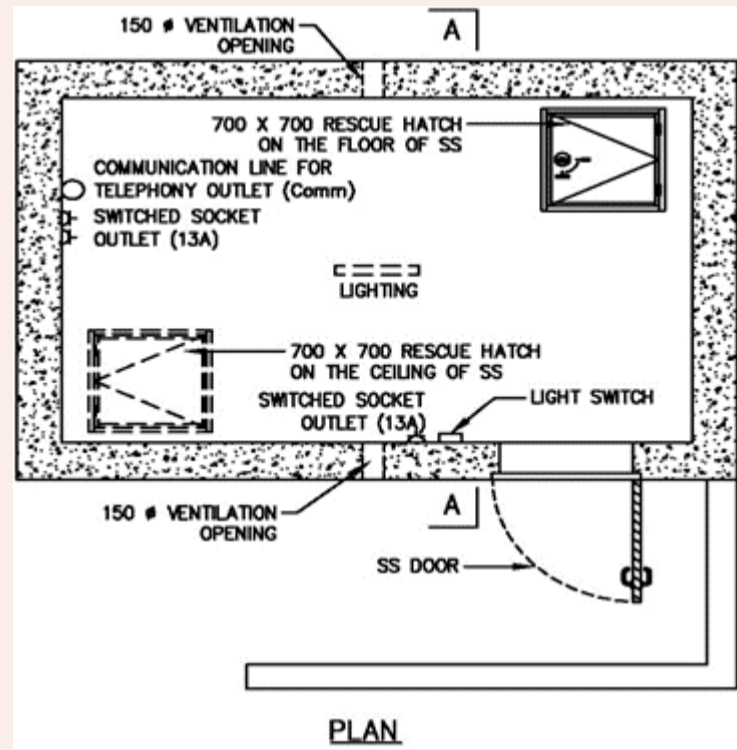

FIGURE 2.6.1(b): FIXTURE IN SS

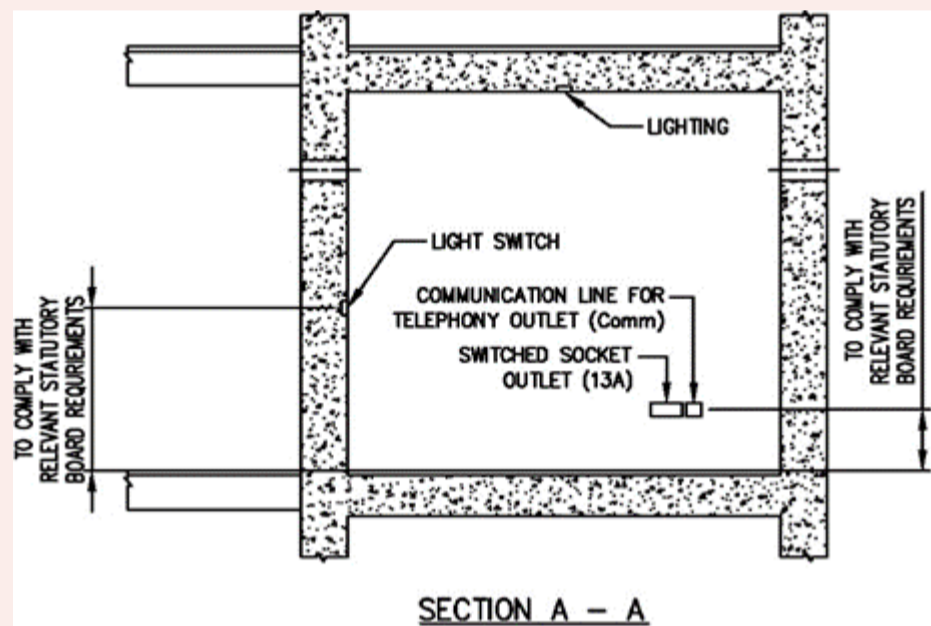

FIGURE 2.12.1(f): TYPICAL PLAN OF S/C SS COMPARTMENT

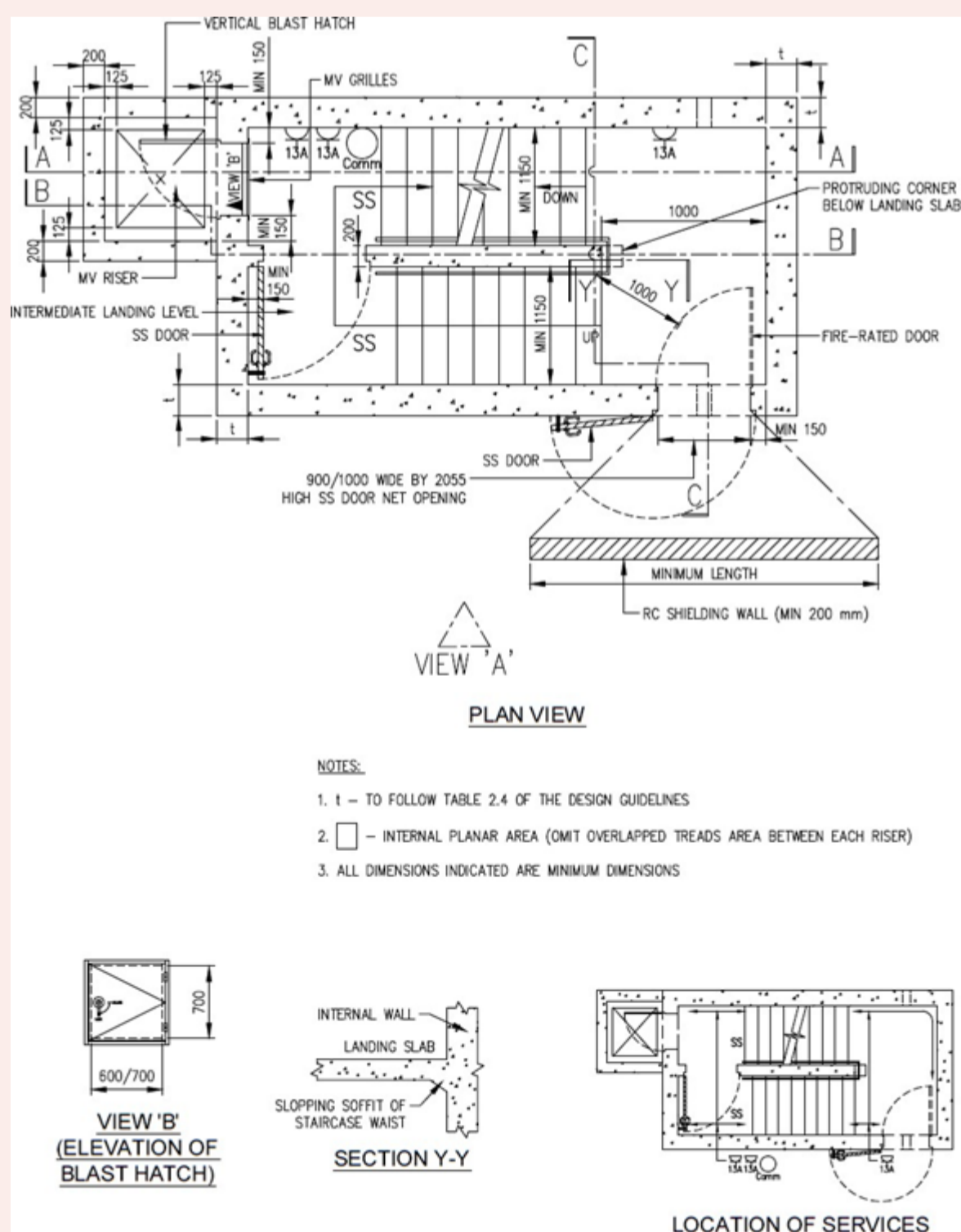
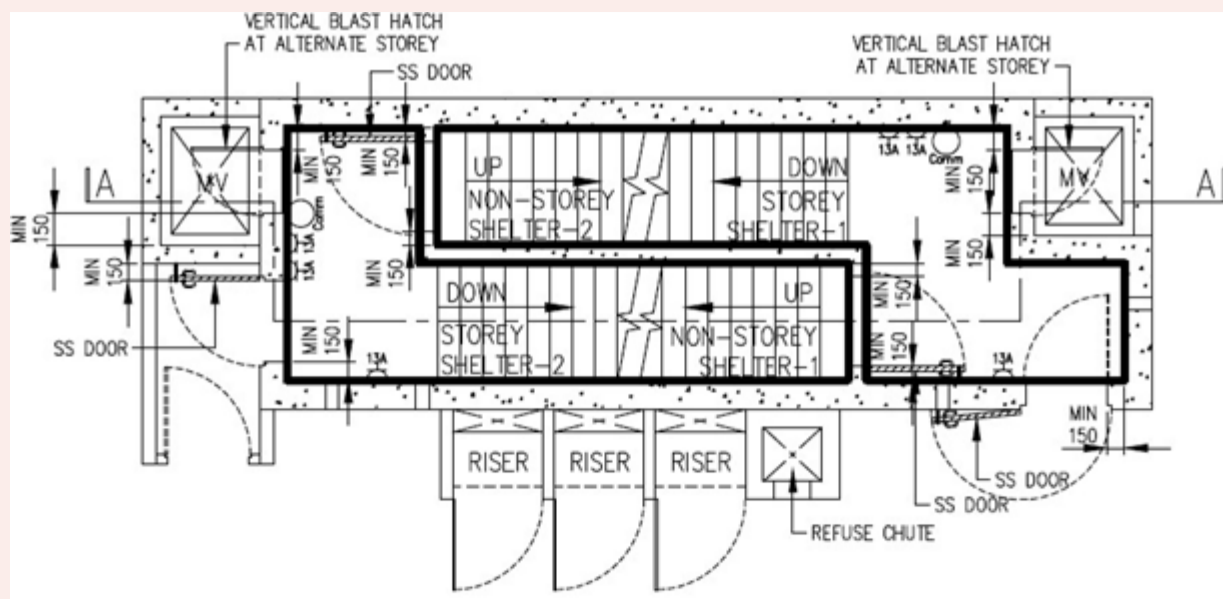
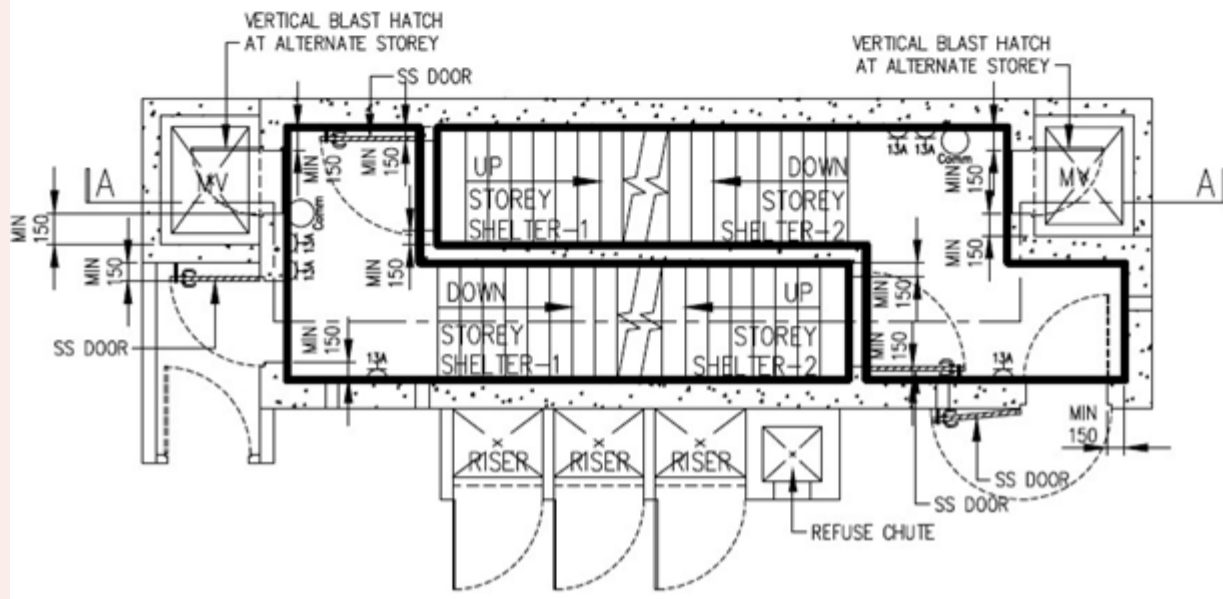

FIGURE 2.12.2(j): SCISSOR S/C SS COMPARTMENT PLAN



TOP-MOST COMPARTMENT PLAN FOR SCISSOR STAIRCASE STOREY SHELTER



TYPICAL STOREY COMPARTMENT PLAN FOR SCISSOR STAIRCASE STOREY SHELTER

- b. The electrical and communication fixtures shall be designed and installed in accordance with the relevant local Codes of Practice and statutory requirements for peacetime usage.
- c. The communication line for telephony outlet in each SS or S/C SS compartment shall have its own independent line where it is connected from the fibre termination point in the compartment to the fibre interface point in the relevant riser of the development.
- d. A maximum of ten numbers of 25mm diameter service conduits for electrical and communication cables serving the SS are allowed. Refer to [Clause 3.6.1](#) for embedment details.
- e. The electrical and communication fixtures shall be located away from the rescue hatch openings in the SS. Refer to [FIGURE 2.6.1\(a\)](#).

Figures & Tables

FIGURE 2.6.1(a): SPECIFIC SS FIXTURE AND OPENINGS

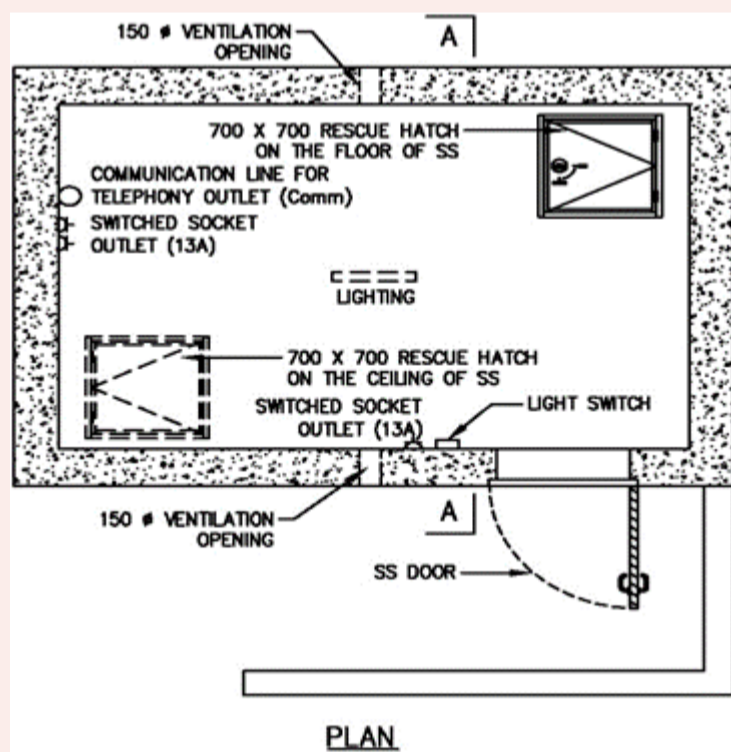

- f. The mounting height of the lighting switch and other electrical and communication fixture shall comply with the relevant statutory board requirements for peacetime use. Refer to [FIGURE 2.6.1\(b\)](#).
- g. Other fixtures, such as cabinets and shelves, which are required for peacetime use in SS, are allowed provided they are easily dismantled and removed.

Figures & Tables

FIGURE 2.6.1(b): FIXTURE IN SS

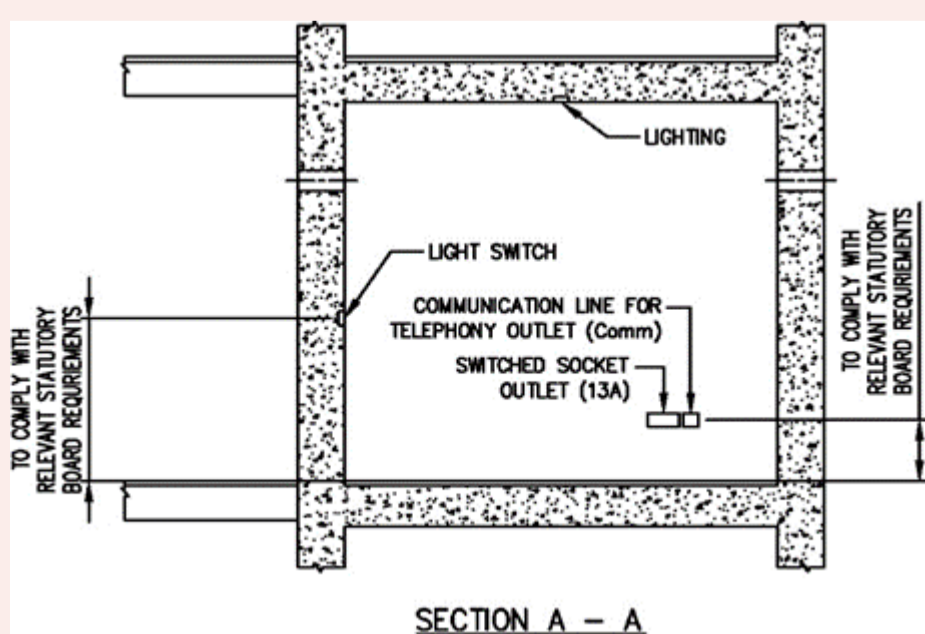

2.6.2 Switch Socket Outlets

- a. For SS:

Three (3) 13A switch socket outlets shall be provided inside each SS. Two switch socket outlets shall be in the vicinity of the communication for telephony outlet located away from the SS door. The third switch socket

outlet shall be located near the ventilation sleeve opening. Refer to FIGURE 2.6.1(a).

Figures & Tables

FIGURE 2.6.1(a): SPECIFIC SS FIXTURE AND OPENINGS

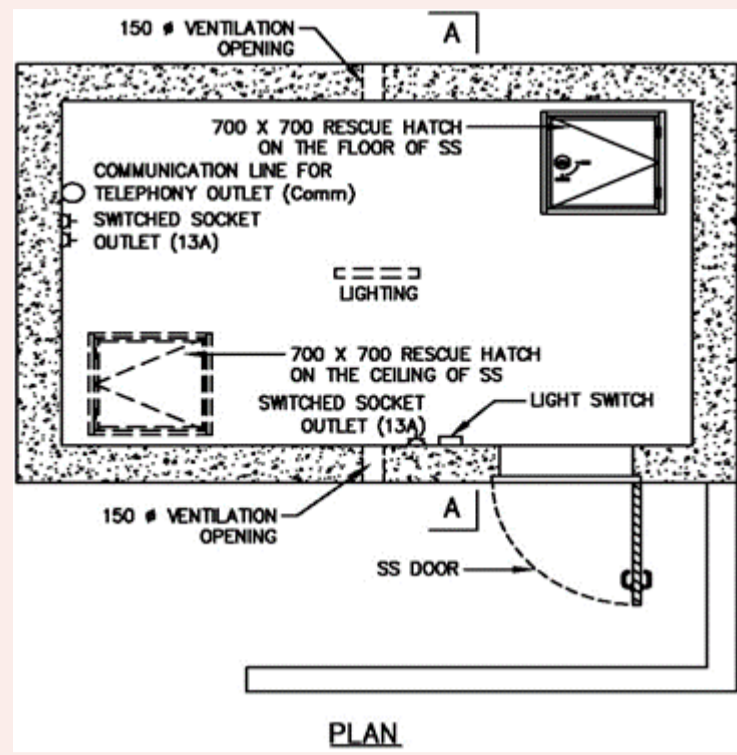

b. For S/C SS

Three (3) 13A switch socket outlets shall be provided inside each S/C SS compartment. At least one switch socket outlet shall be provided at the main landing. The other two switch socket outlets shall be provided at the intermediate landing together with the communication for telephony outlet. Refer to FIGURE 2.12.1(f) for details.

Figures & Tables

FIGURE 2.12.1(f): TYPICAL PLAN OF S/C SS COMPARTMENT

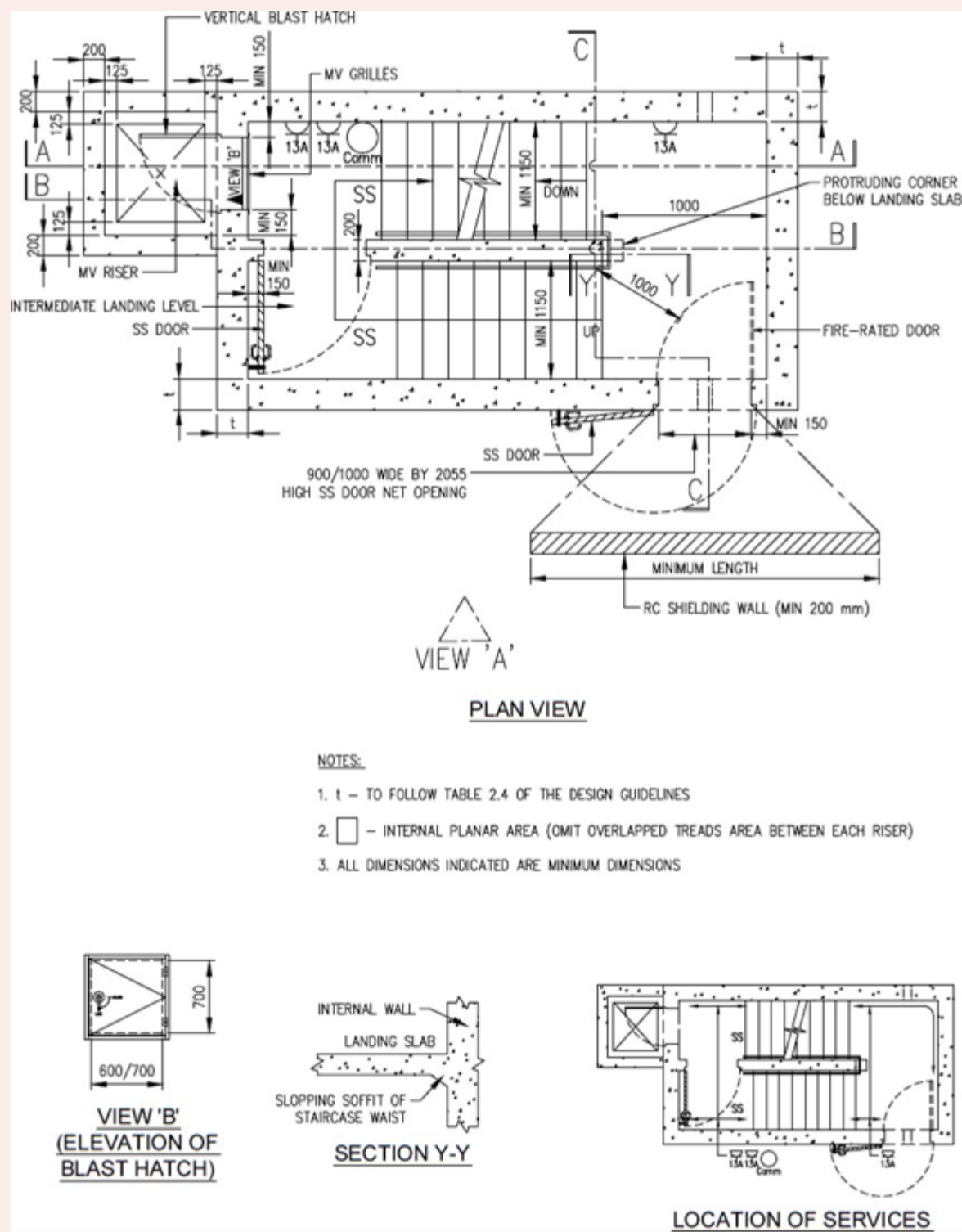

c. For Scissor S/C SS

Three (3) 13A switch socket outlets shall be provided inside each scissor S/C SS compartment. At least one switch socket outlet shall be provided at the main landing at the upper floor of the SS compartment. The other two switch socket outlets shall be provided at the main landing, together with the communication for telephony outlet at the lower floor of the SS compartment. Refer to FIGURE 2.12.2(j) for details.

Figures & Tables

FIGURE 2.12.2(j): SCISSOR S/C SS COMPARTMENT PLAN

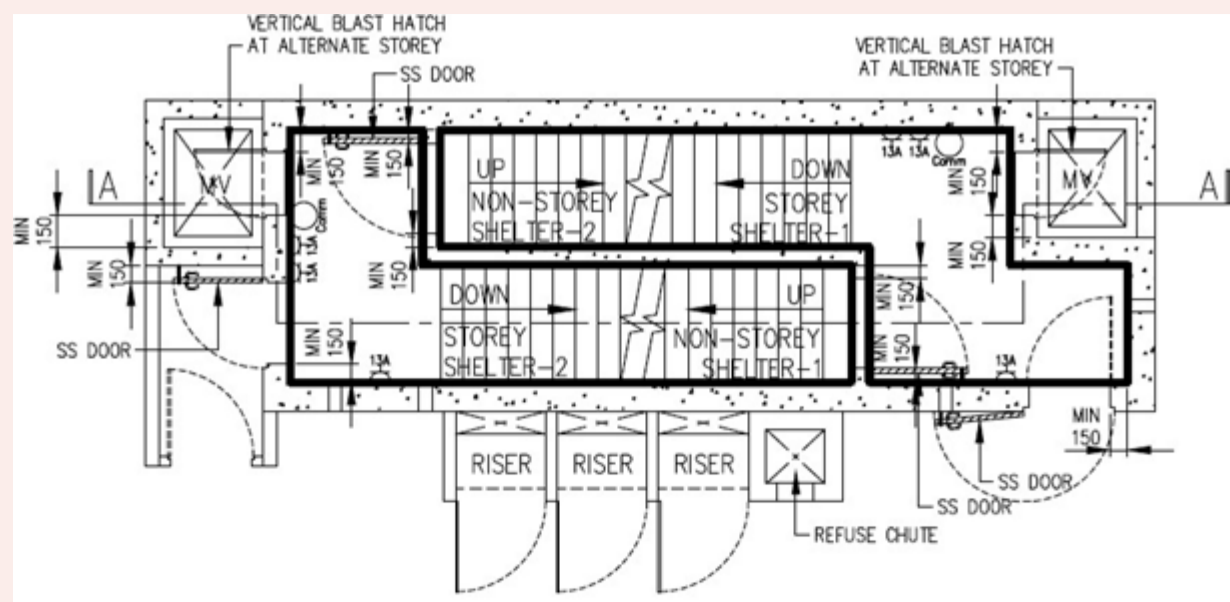

TOP-MOST COMPARTMENT PLAN FOR
SCISSOR STAIRCASE STOREY SHELTER

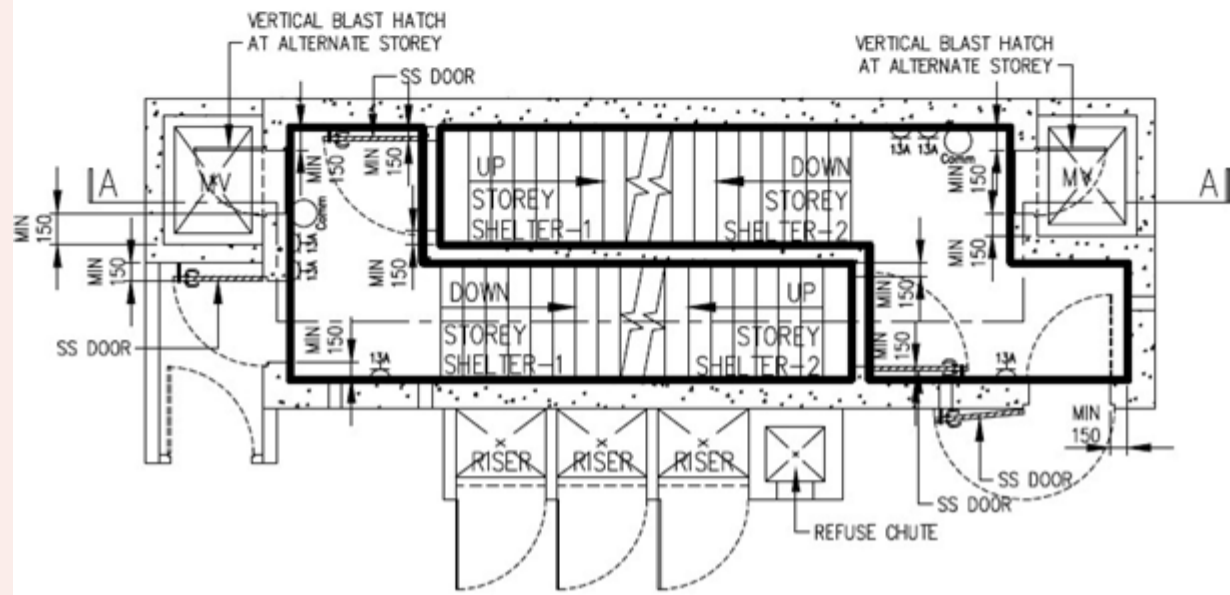

TYPICAL STOREY COMPARTMENT PLAN FOR
SCISSOR STAIRCASE STOREY SHELTER

2.6.3 Light Fitting

Light fittings shall be mounted only on the soffit of SS ceiling with screws, using non-metallic inserts. Wall mounted luminaries are not permitted.

2.6.4 Cable Entries and Openings

All cable entries shall be fully and properly sealed for air-tightness as stipulated in [Clause 3.6.1](#).

CLAUSE 2.7 NS IN SS TOWER

2.7.1 Aggregate Wall Height of NS

- a. Several NS can be stacked one on top of the other within an SS tower, without the need for NS floor slab to be connected to external floor slab, provided that the aggregate wall height of the NS does not exceed 12m. Refer to FIGURE 2.7.1.

Figures & Tables

FIGURE 2.7.1: NS IN SS TOWER

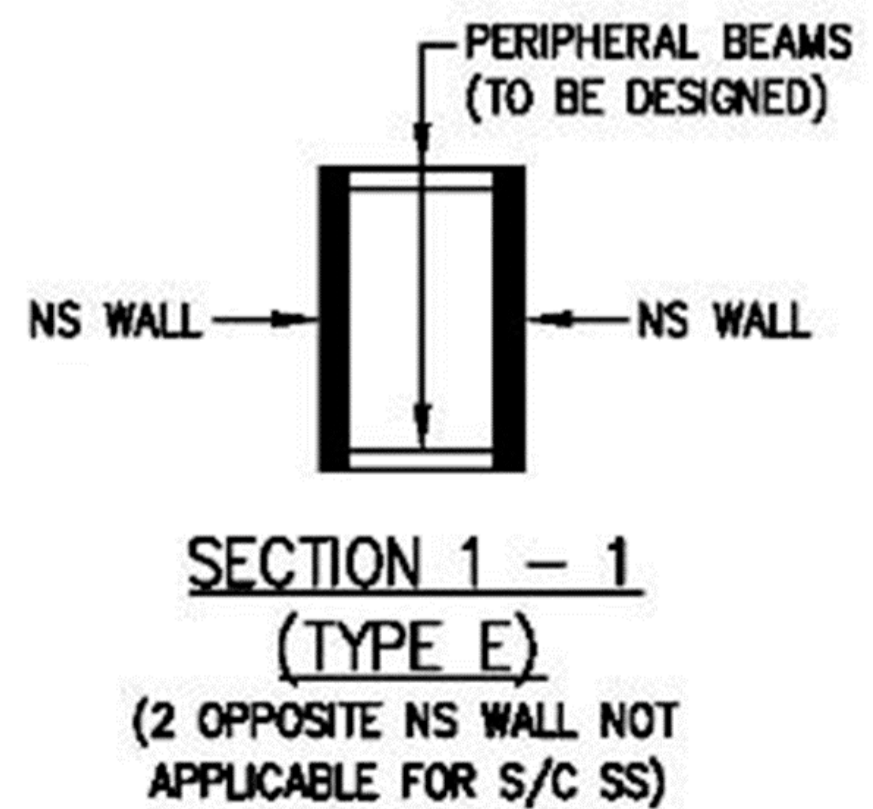
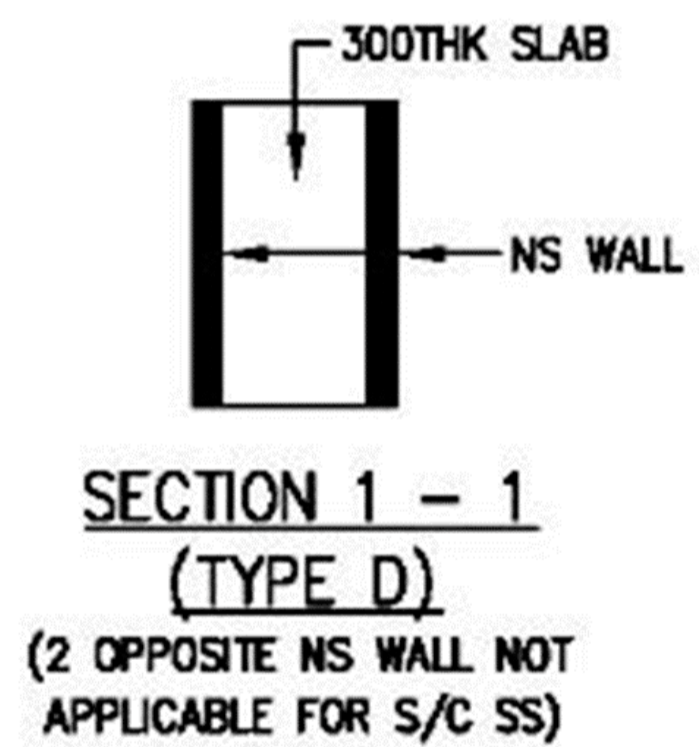
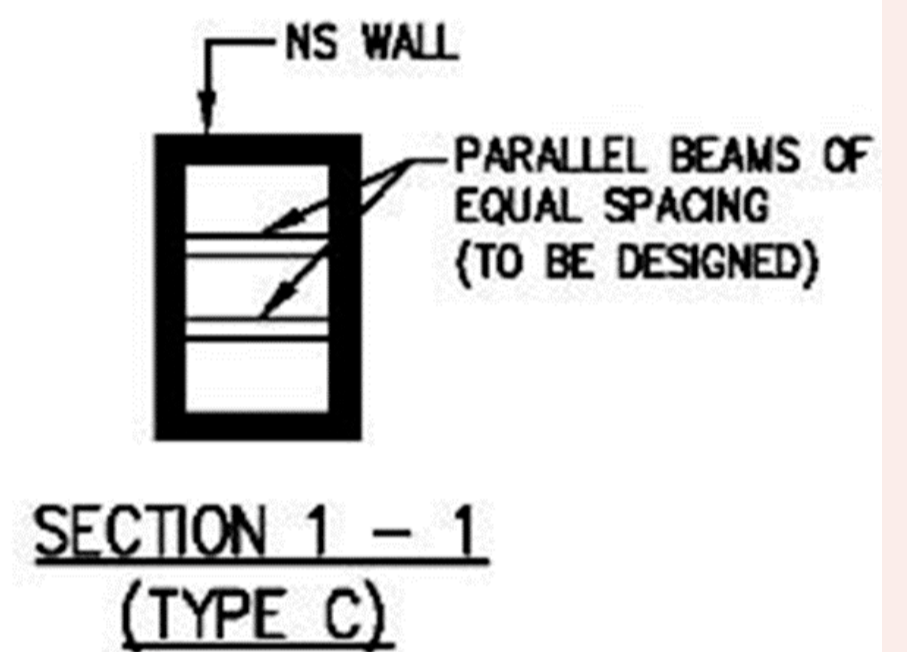
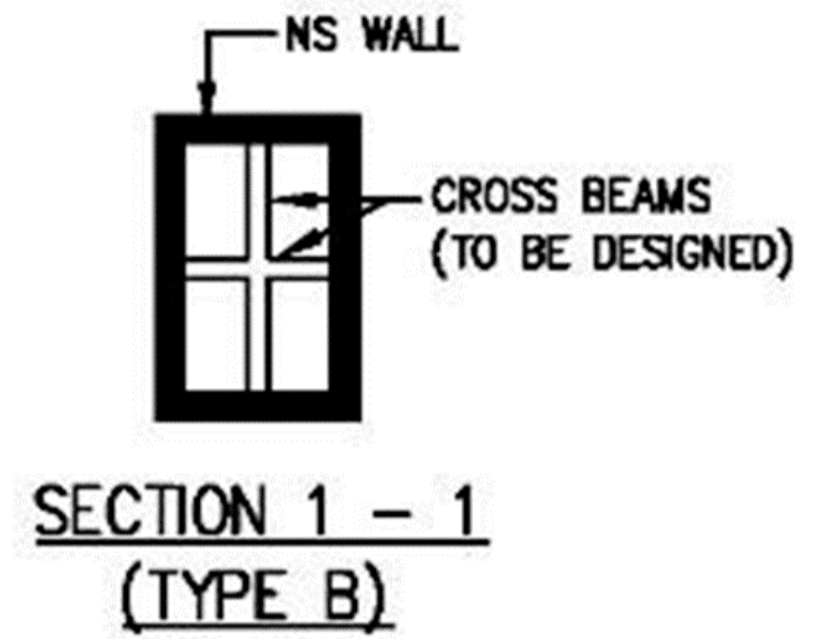
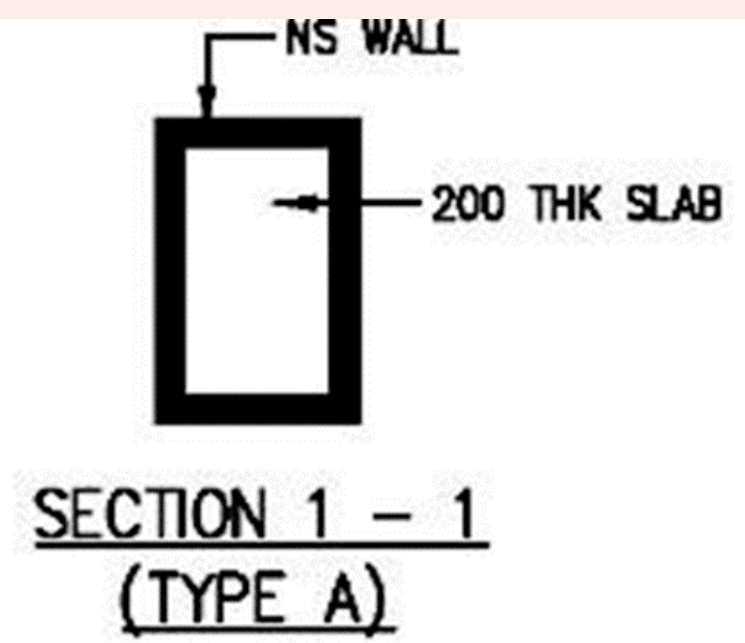
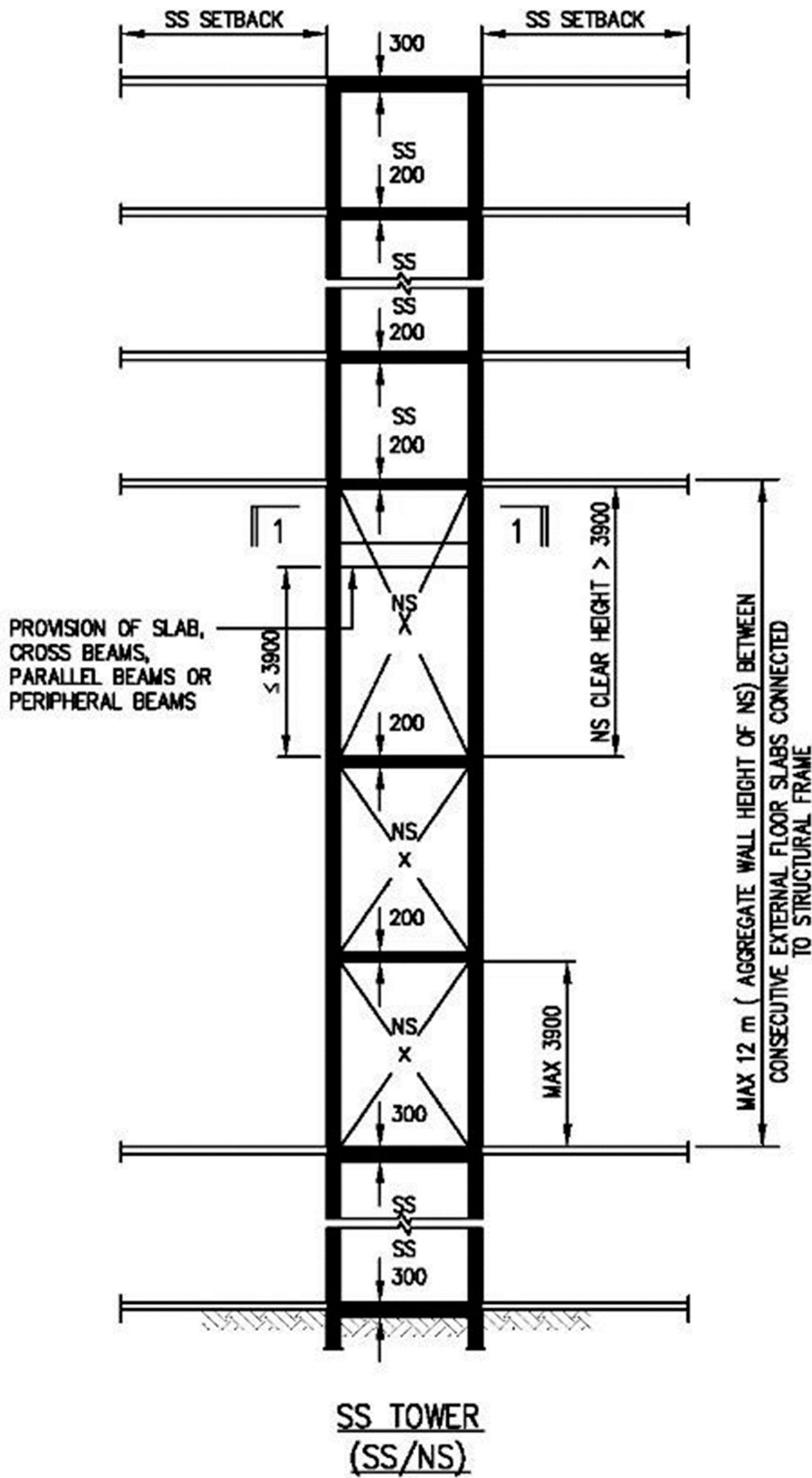

b. Aggregate wall height of NS refers to the sum of the height(s) of NS between two levels of the SS tower where the full external perimeter of the SS tower at those levels are structurally connected by floor slabs or tie beams to the structural frame of the building. Where tie beams are used, they shall be designed with at least equivalent stiffness to the floor slabs.

2.7.2 Shielded and Unshielded NS Walls

The relevant architectural technical requirements of the shielded or unshielded NS Walls as stipulated in [Clause 3.3.3](#) & [3.3.4](#) shall be complied with.

CLAUSE 2.8 FINISHES IN SS

Finishes within a SS shall comply with the following:

- a. The walls and the ceiling slab shall be cast with a smooth concrete finish.
- b. The walls and ceiling slab may be finished with a skim coat of not thicker than 2mm.
- c. No plastering or tiling shall be permitted on the walls and ceiling slab.
- d. Floor tiles or floor finishes, which are laid on wet cement mortar, are permitted.
- e. Skirting tiles laid on wet cement mortar are permitted up to a maximum 100mm high above the FFL.

CLAUSE 2.9 EXIT STAIRCASE

- a. Where there is only one exit staircase or scissors-staircase serving the dwelling units, the minimum waist of exit staircase and the thickness of the intermediate landing slab shall be 150mm. The staircase shall be constructed of reinforced concrete.
- b. If the exit staircase or scissors-staircase are designed as the S/C SS, the waist of the staircase shall be minimum 200mm.

CLAUSE 2.10 DOOR RECESS

A door recess on SS or S/C SS external wall, to accommodate the protrusion of the door handle when the SS door is fully open, shall be provided. Refer to FIGURE 2.10.

- a. The dimensions shall not be larger than 160mm (length) x 80mm (height) x 40mm (depth) for SS or S/C SS wall of minimum 300mm thickness and shall accommodate the door handle adequately.
- b. The clear spacing between the SS door handle recess and the external socket outlet/ other fixtures or internal fixtures shall be at least 300mm apart.

Figures & Tables

FIGURE 2.10: DETAILS OF WALL RECESS FOR SS DOOR HANDLE

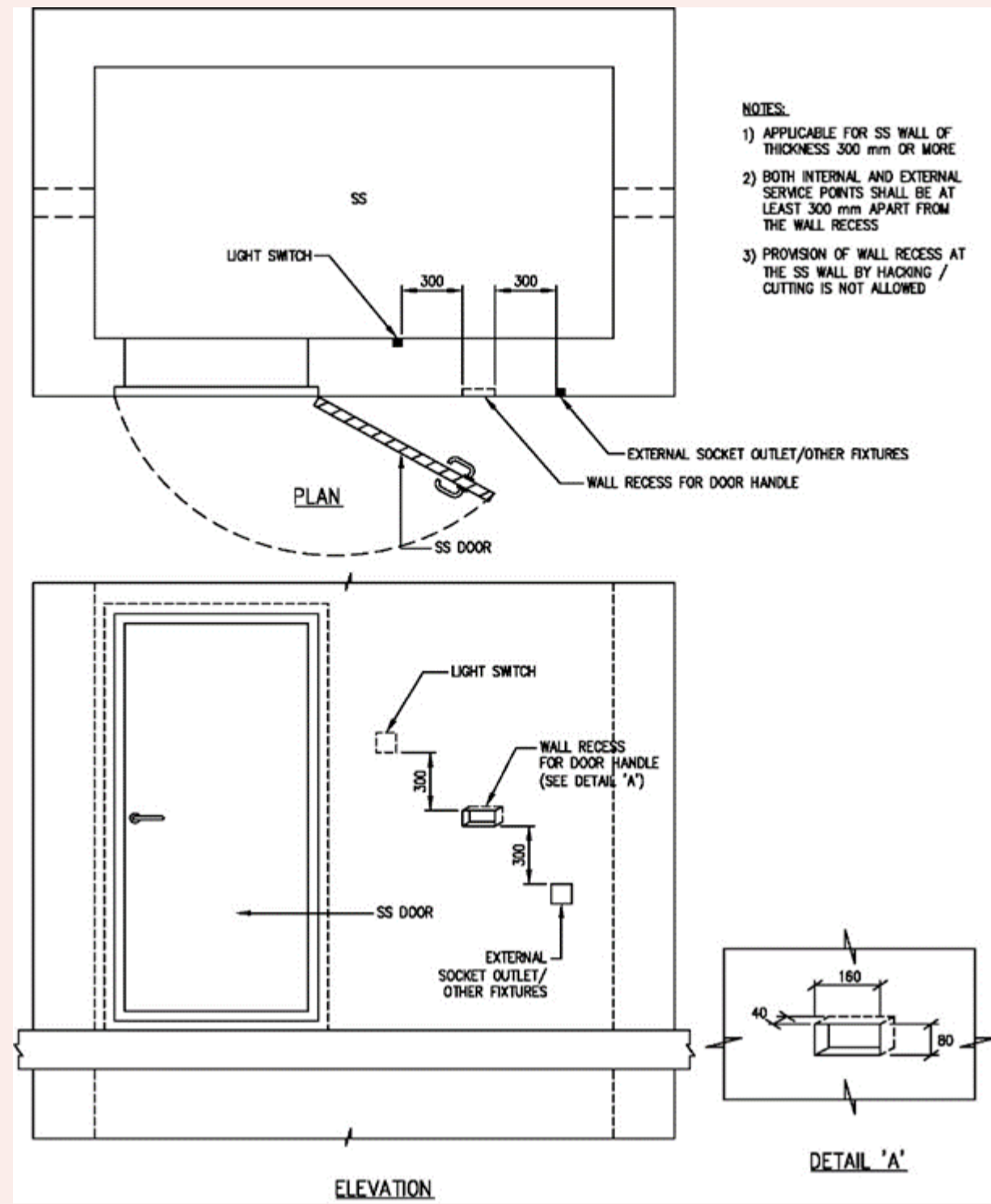

CLAUSE 2.11 DESIGN REQUIREMENTS OF SS

2.11.1 Rescue Hatch

- a. A rescue hatch shall be provided on the floor and ceiling on every SS in a SS tower, except that the bottom-most SS shall not have a rescue hatch in its floor and the top-most SS shall not have a rescue hatch in its ceiling. The hatch shall be made of airtight sealed galvanised steel and shall comply with relevant fire safety requirements for compartmentalisation of the SS*. (* QP is advised to look into the fire safety requirements of their designs for compartmentalisation of the SS).
- b. The rescue hatch opening in an SS shall be positioned adjacent to the SS walls with minimum dimensions as shown in FIGURE 2.11.1(a). The vertical centreline of the rescue hatch opening in the ceiling shall be offset from the centreline of the rescue hatch in the floor of the same SS by at least 1400mm. Refer to FIGURE 2.11.1(b).

Figures & Tables

FIGURE 2.11.1(a): MINIMUM DISTANCE OF RESCUE HATCH FROM SS WALL

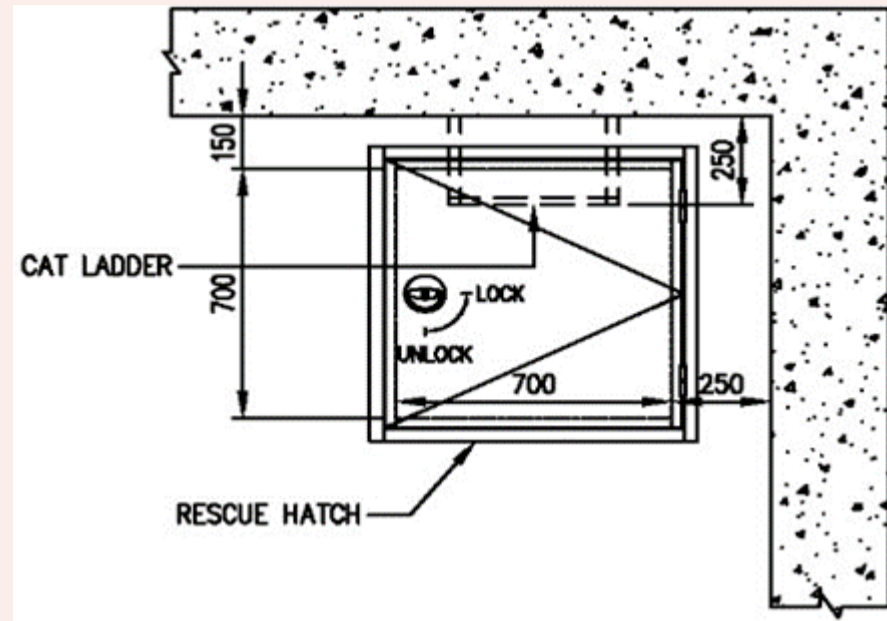
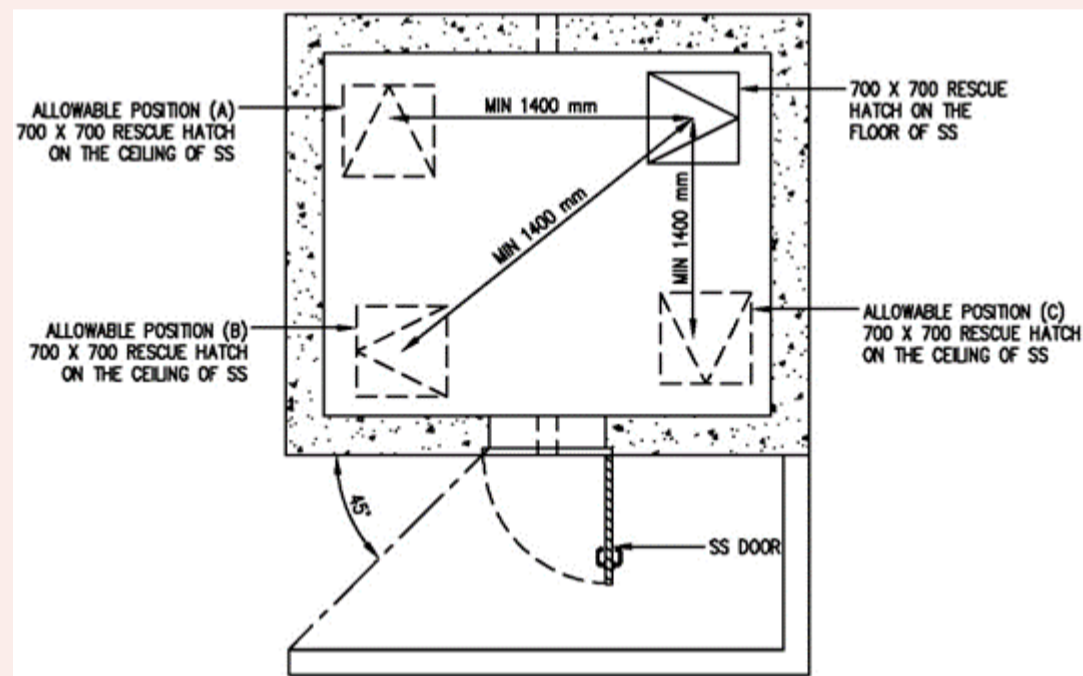

FIGURE 2.11.1(b): MINIMUM DISTANCE BETWEEN CENTRE LINES OF RESCUE HATCH



- c. The clear opening of the rescue hatch shall be 700mm x 700mm. The dimensions of the rescue hatch are as shown in FIGURE 2.11.1(c).

Figures & Tables

FIGURE 2.11.1(c): MINIMUM DIMENSIONS OF RESCUE HATCH

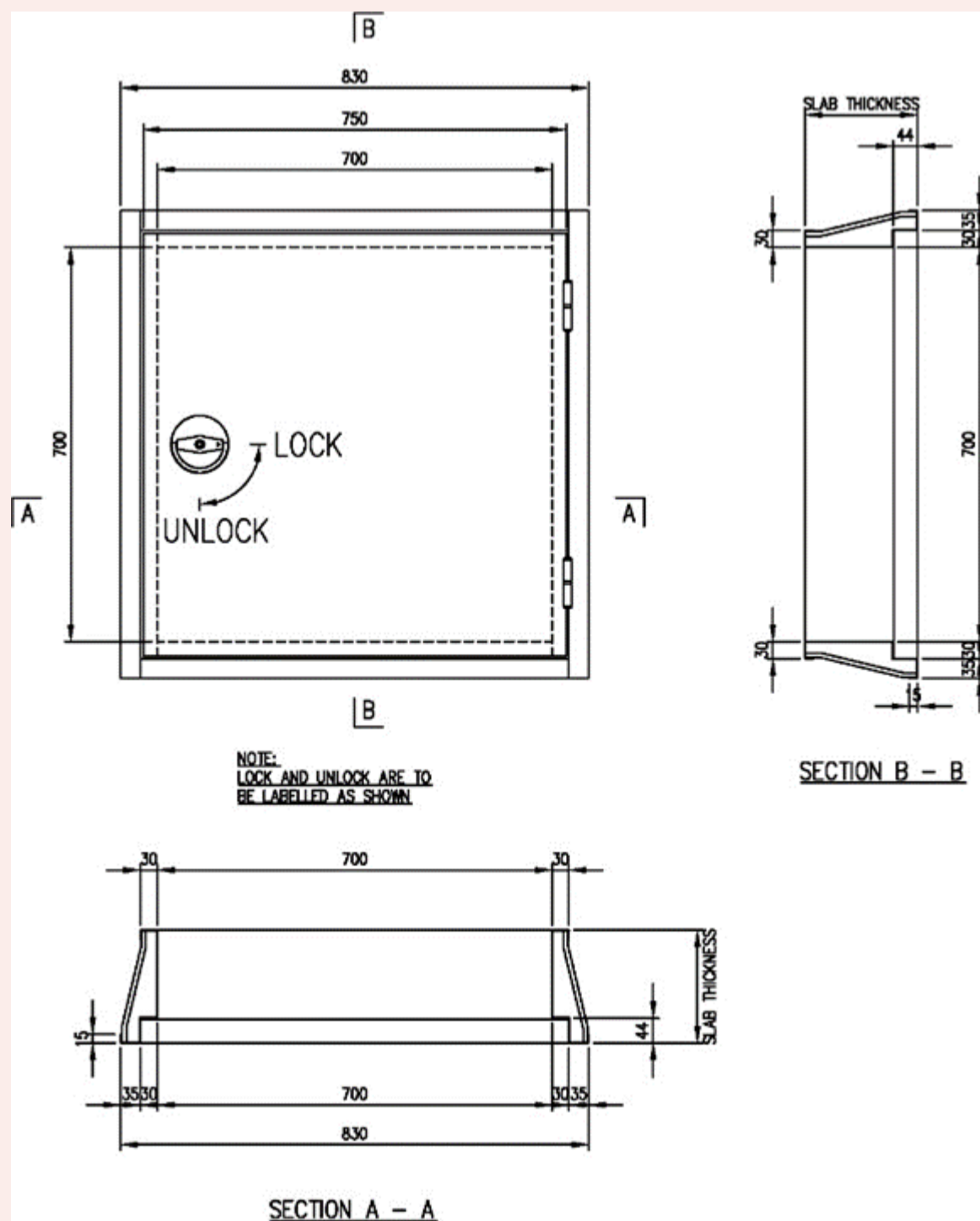

2.11.2 Cat-Ladder

Cat-ladder shall be provided for access through rescue hatch opening. The cat-ladder shall be made of either stainless steel or aluminium or equivalent. The mounting connections of cat-ladder to the SS wall shall be designed to withstand shock loads of at least 12.5g in all directions, where g is the gravitational acceleration, details and dimensions as shown in FIGURE 2.11.2.

Figures & Tables

FIGURE 2.11.2: DETAILS OF CAT LADDER TO SS WALL

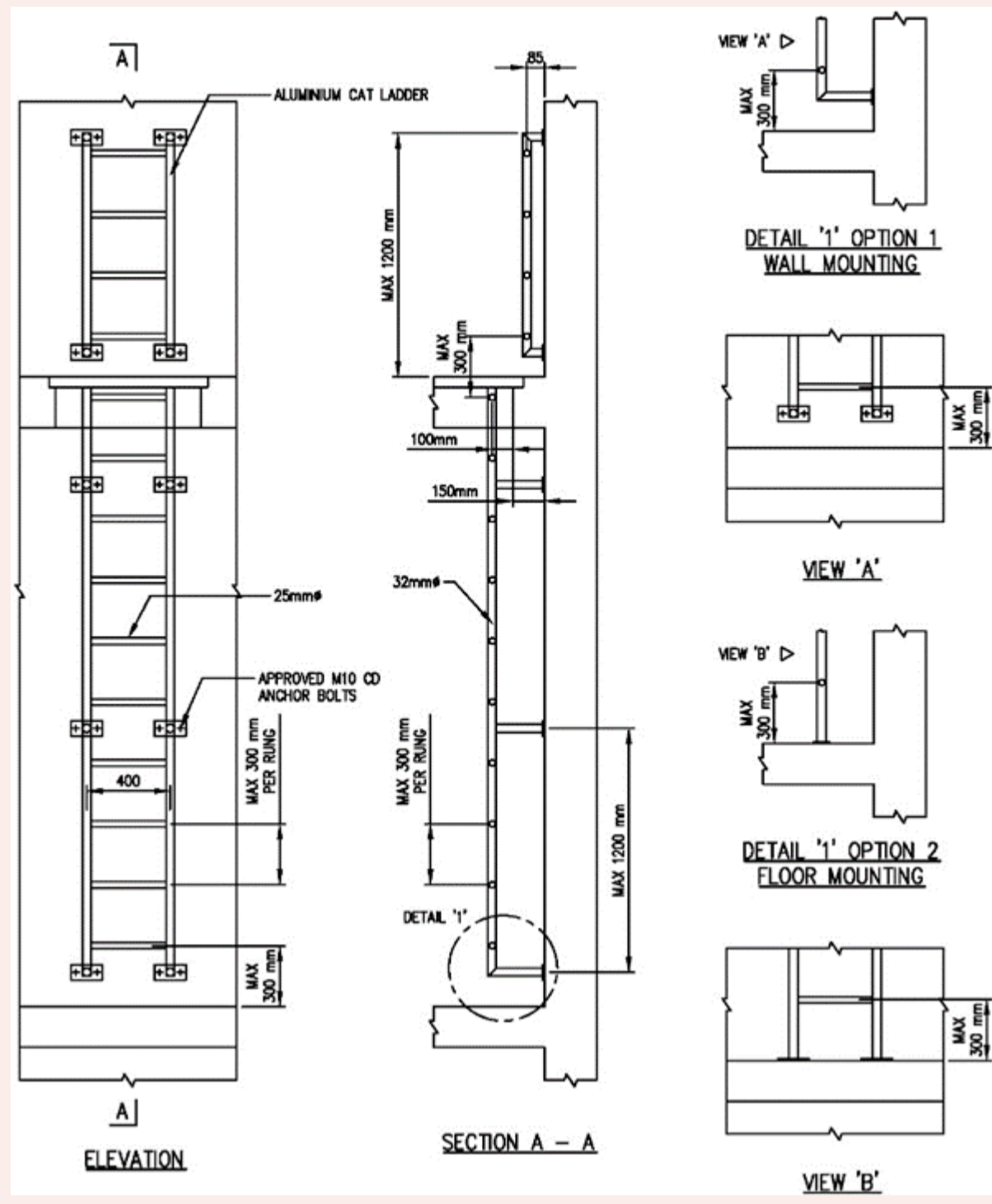

CLAUSE 2.12 DESIGN REQUIREMENTS OF S/C SS AND SCISSOR S/C SS

2.12.1 General

a. The protection carcass shall be formed by external SS wall, floor slab of the bottom-most shelter compartment and the ceiling slab of the top-most shelter compartment. FIGURE 2.12.1(a) to 2.12.1(c).

Figures & Tables

FIGURE 2.12.1(a) to 2.12.1(c)

FIGURE 2.12.1(a): SECTION X-X OF S/C SS WITH SS/NS

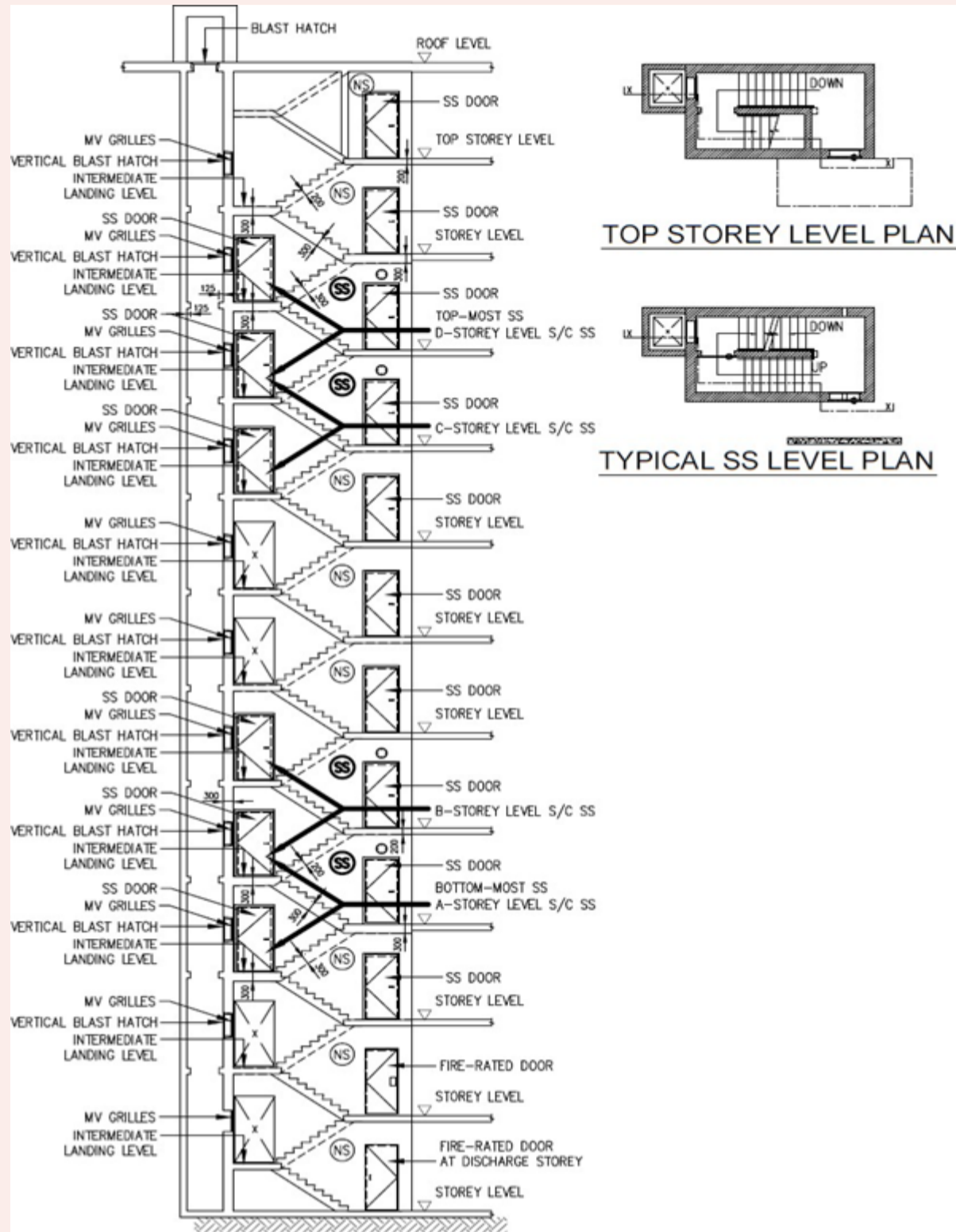

FIGURE 2.12.1(b): PROTECTION CARCASS OF S/C SS TOWER

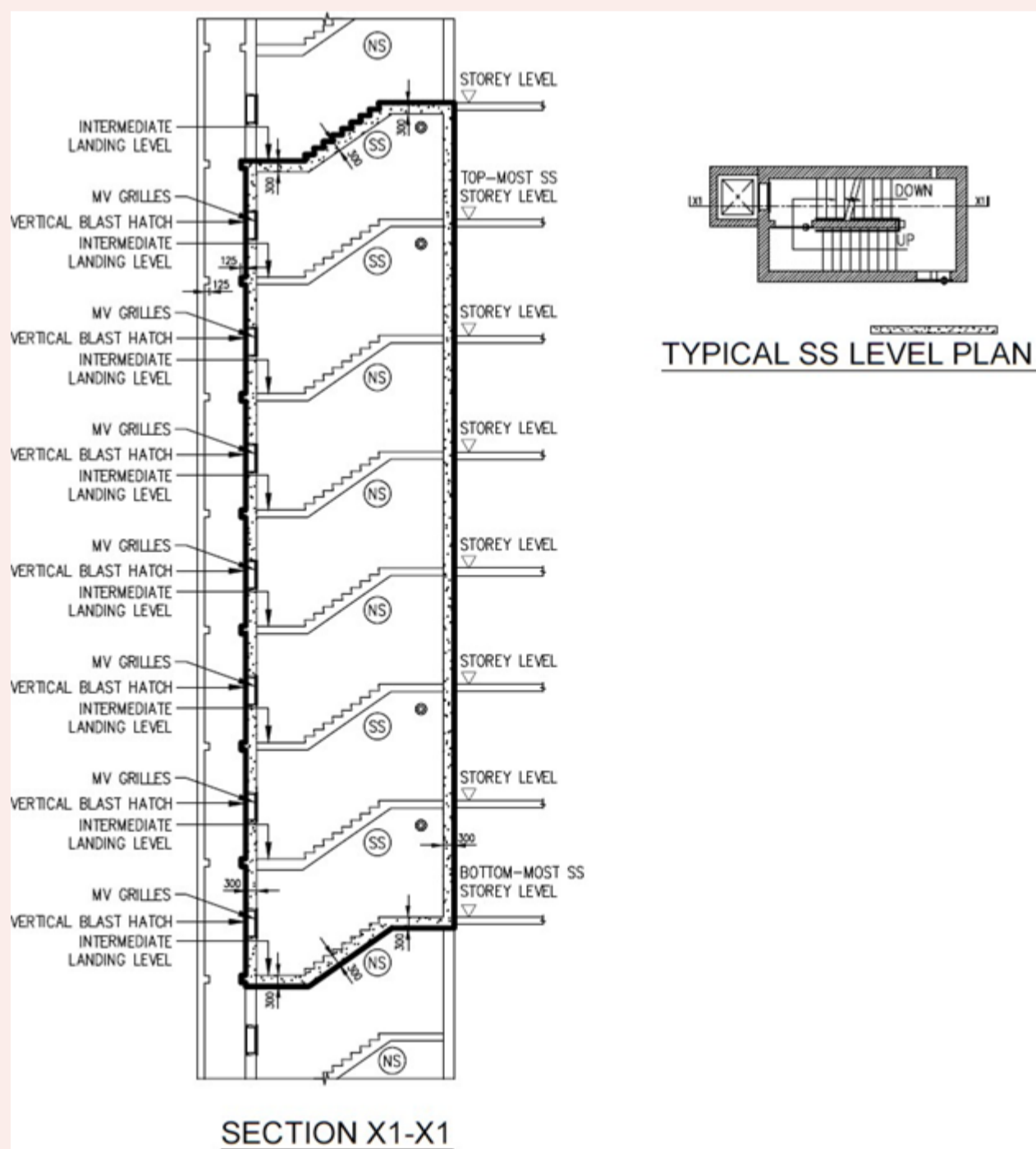
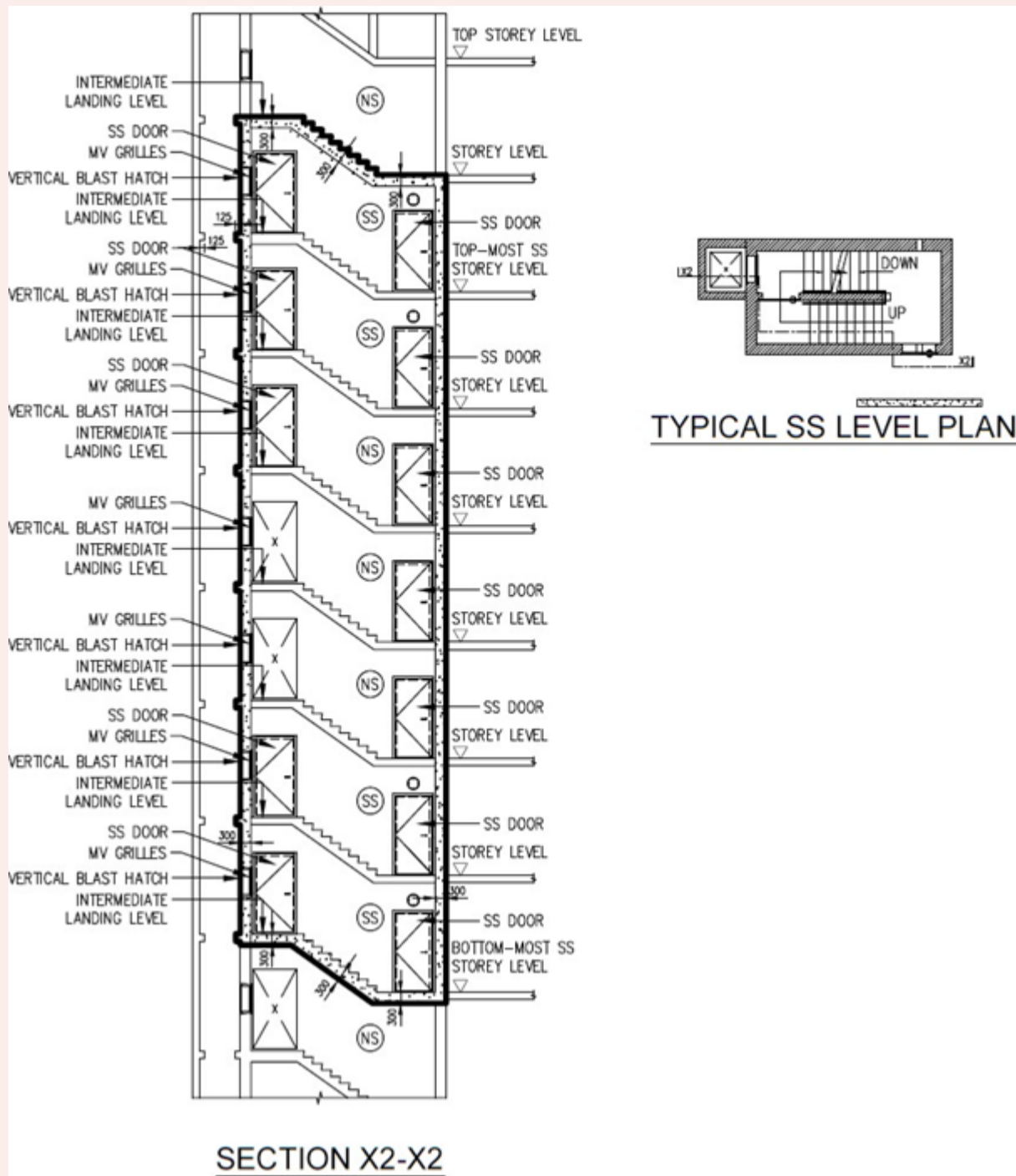

FIGURE 2.12.1(c): PROTECTION CARCASS OF S/C SS TOWER



- b. In the case of NS interspersed within the S/C SS or scissor S/C SS tower, SS doors and vertical blast hatches shall be provided to the opening leadings to the following NS. Refer to Figure 2.12.1(d) to 2.12.1(h).
- i. One NS immediately below the bottom-most SS.
 - ii. Two NS immediately above the top-most SS.
 - iii. NS between SS compartments.

Figures & Tables

Figure 2.12.1(d) to 2.12.1(h)

FIGURE 2.12.1(d): PLAN OF NON-SHELTER (NS) ABOVE TOP-MOST S/C SS COMPARTMENT

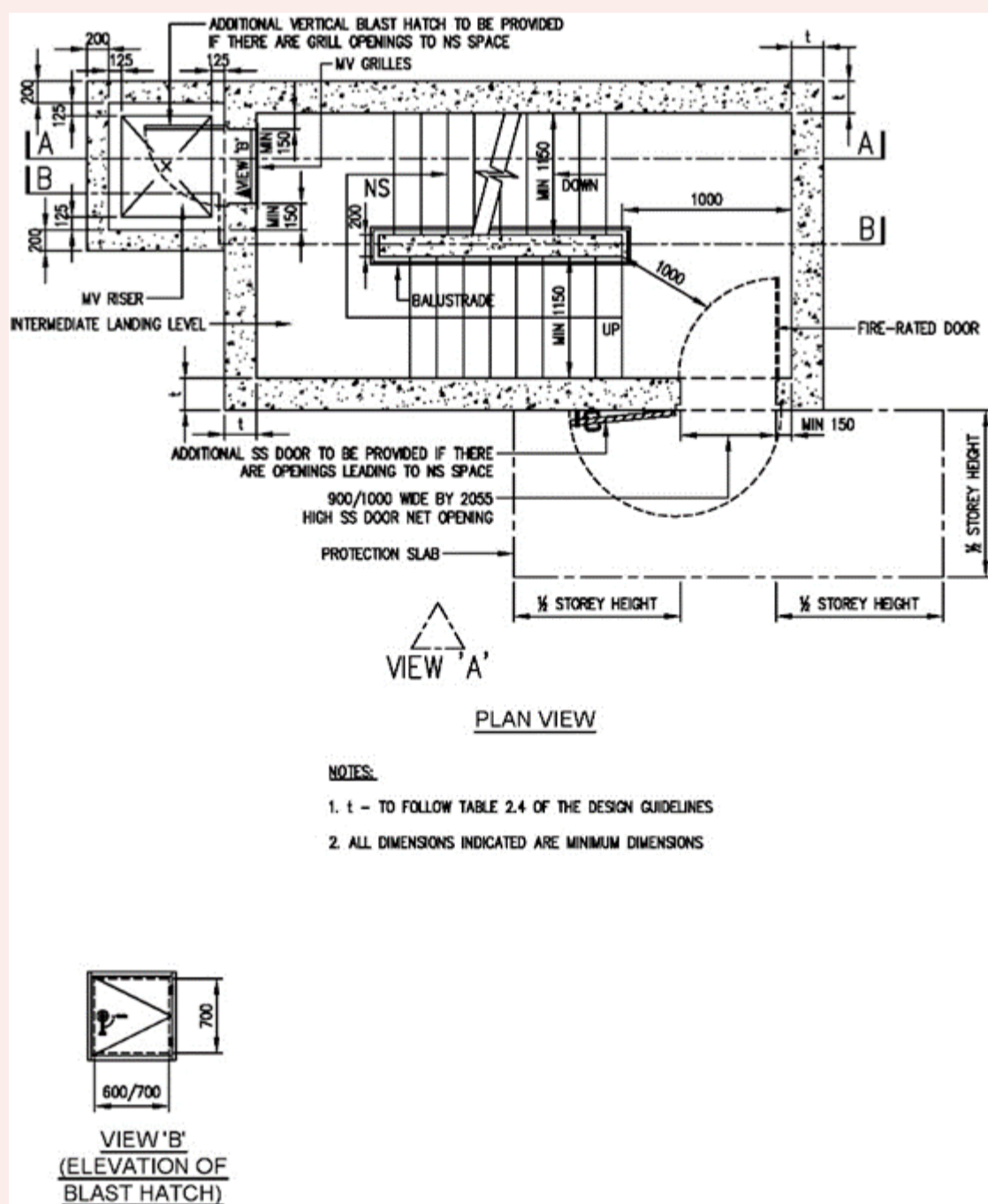

FIGURE 2.12.1(e): PLAN OF TOP-MOST S/C SS COMPARTMENT

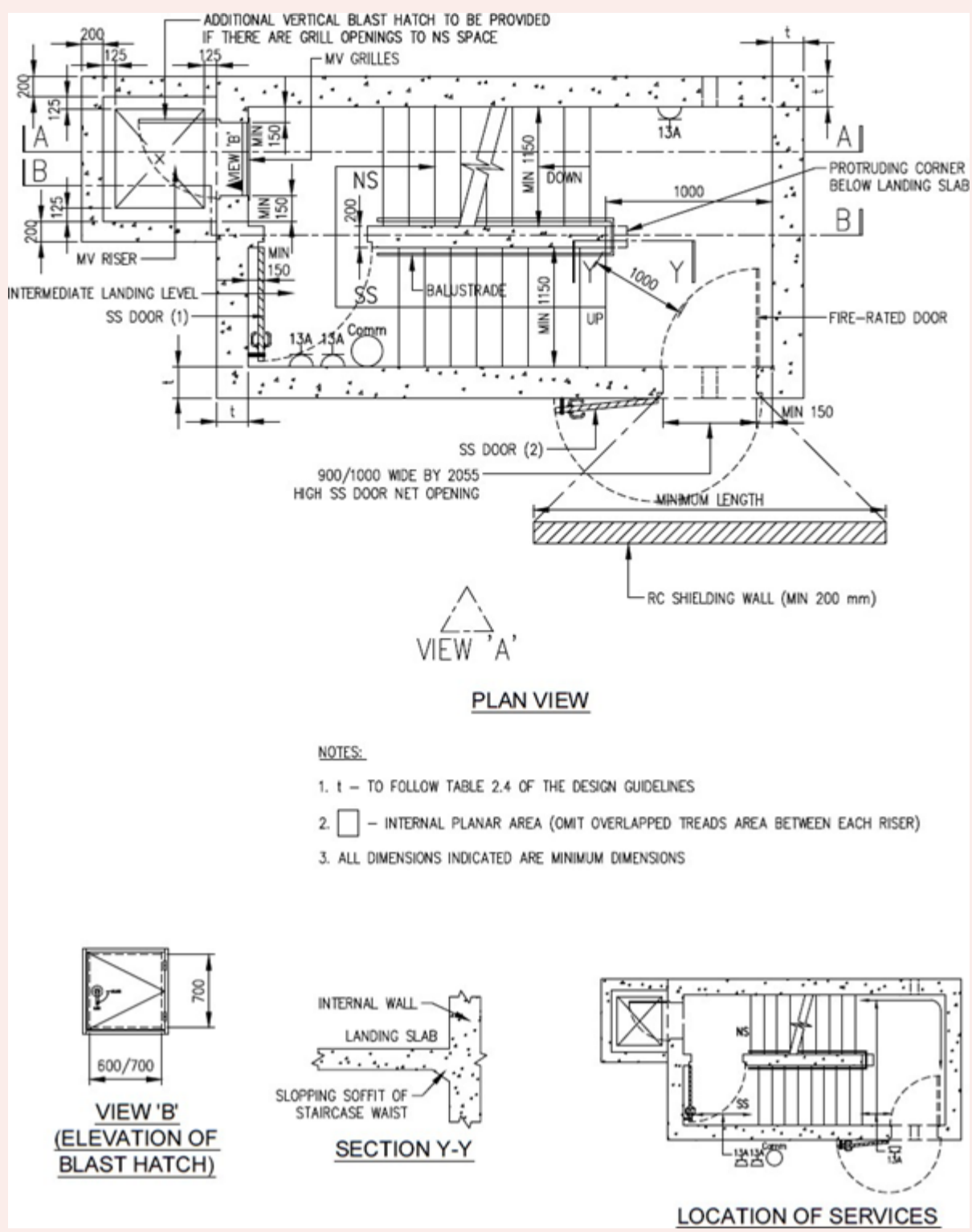

FIGURE 2.12.1(f): TYPICAL PLAN OF S/C SS COMPARTMENT

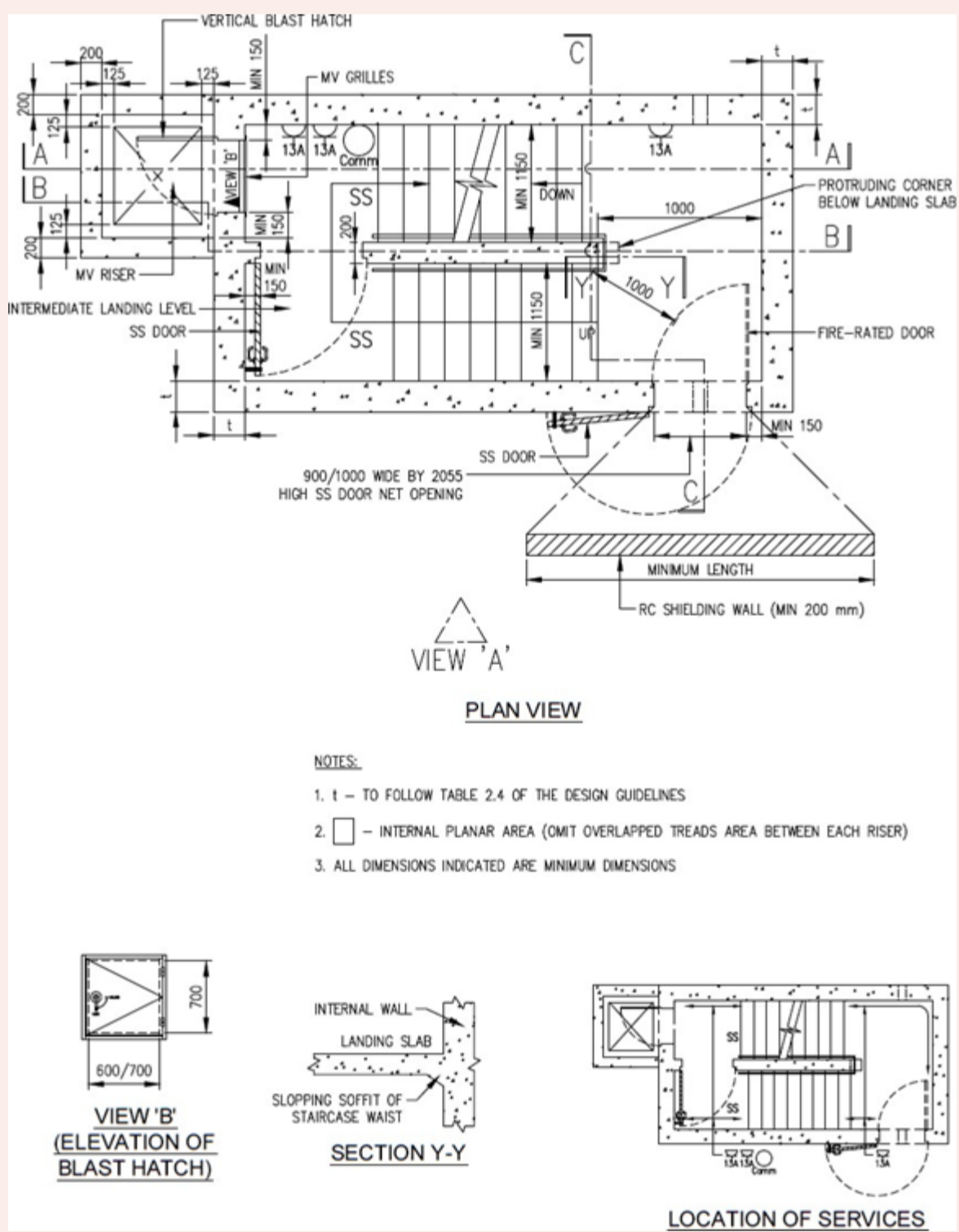

FIGURE 2.12.1(g): PLAN OF BOTTOM-MOST S/C SS COMPARTMENT

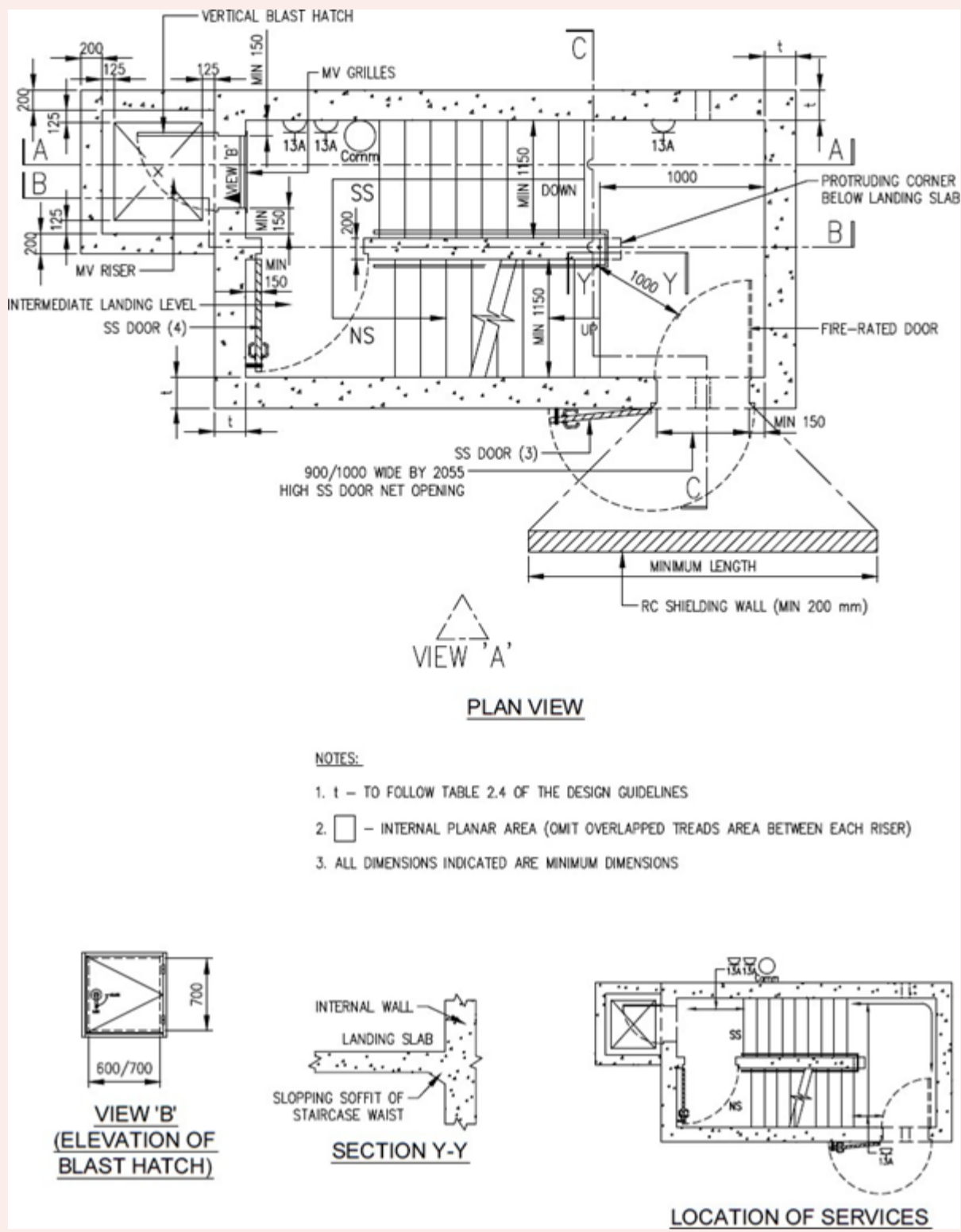
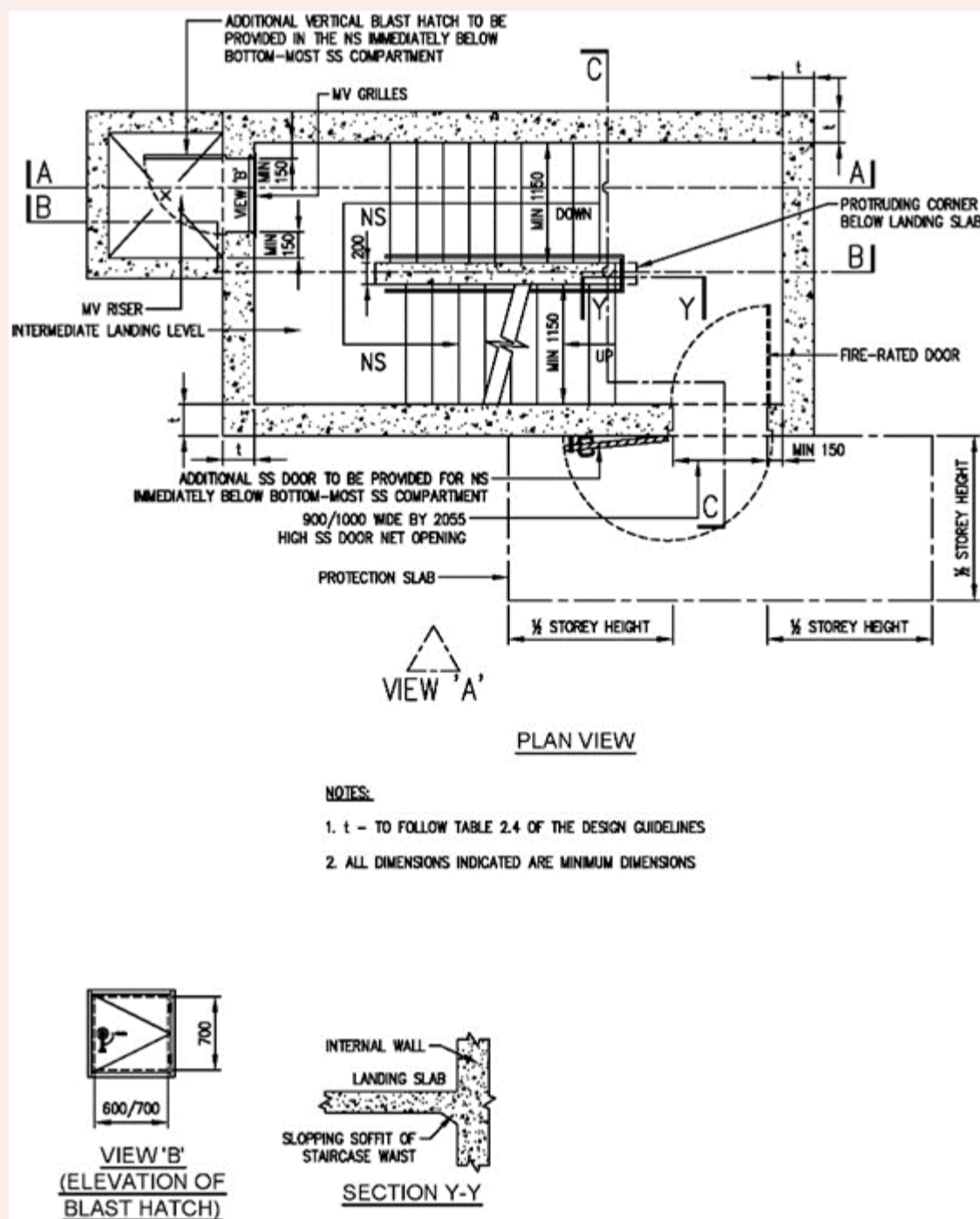

FIGURE 2.12.1(h): PLAN OF NS IMMEDIATELY BELOW BOTTOM-MOST S/C SS COMPARTMENT



c. All SS doors are to be kept opened permanently during peacetime. As such, a door holder shall be provided to hold the door in open position. Refer to FIGURE 2.12.2(i).

Figures & Tables

FIGURE 2.12.2(i): DETAIL OF SS DOOR HOLDER

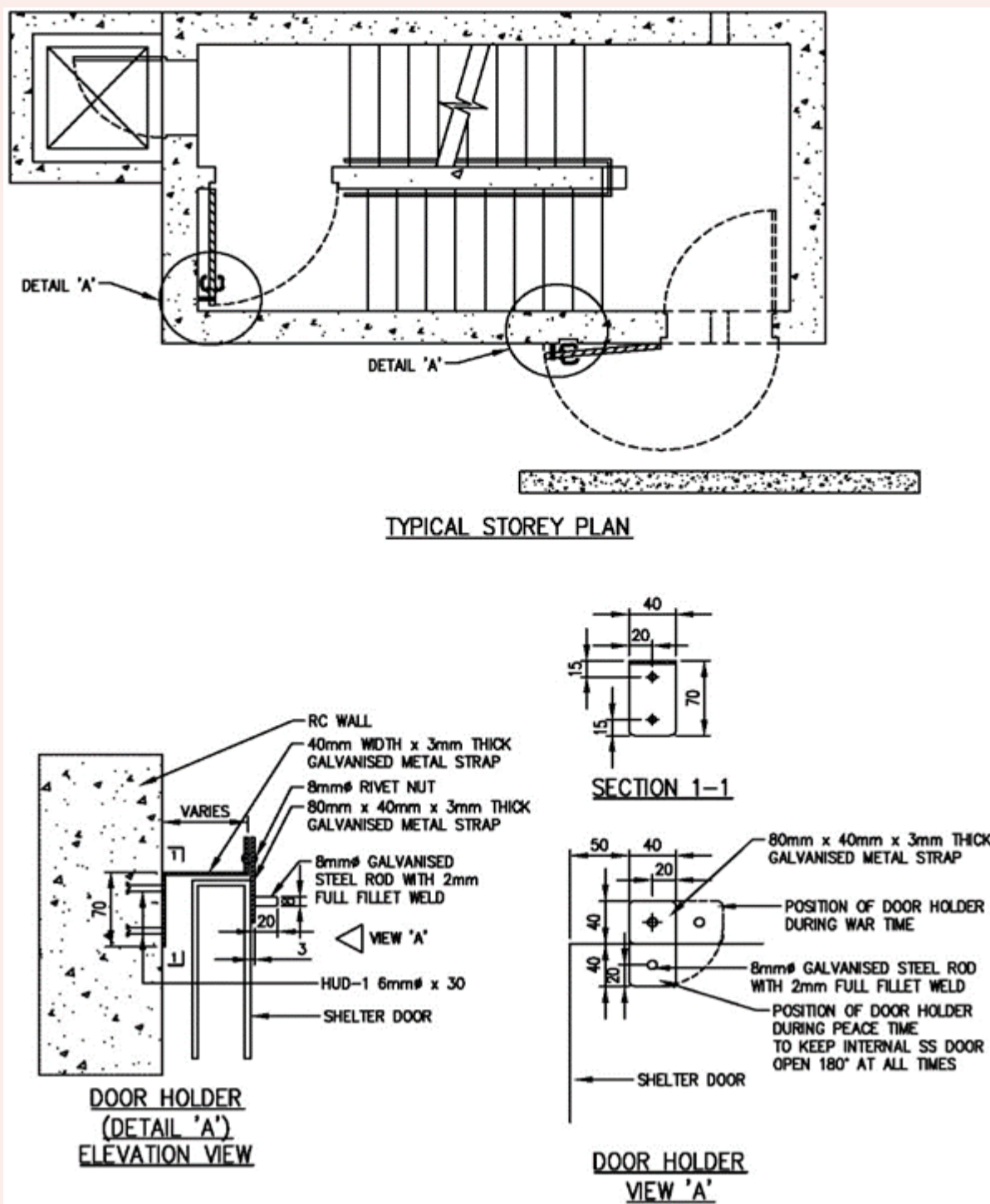

d. S/C SS and scissor S/C SS have to be mechanically ventilated for peacetime purpose. The number of mechanical ventilation (MV) openings is based on the peacetime MV design. Where there are MV openings, grille openings for entry of ventilating air via mechanical ventilation (MV) riser are permitted. Refer to Figure 2.12.2(c). Typically, for a scissor S/C SS, the MV openings are at alternate floors of each SS tower as shown in FIGURE 2.12.2(j) and 2.12.2(k).

Figures & Tables

Figure 2.12.2(c), FIGURE 2.12.2(j) and 2.12.2(k)

FIGURE 2.12.2(c): SS WITH NS ABOVE TOP-MOST SS COMPARTMENT, INTERMEDIATE SS COMPARTMENT AND SS WITH NS BELOW BOTTOM-MOST SS COMPARTMENT

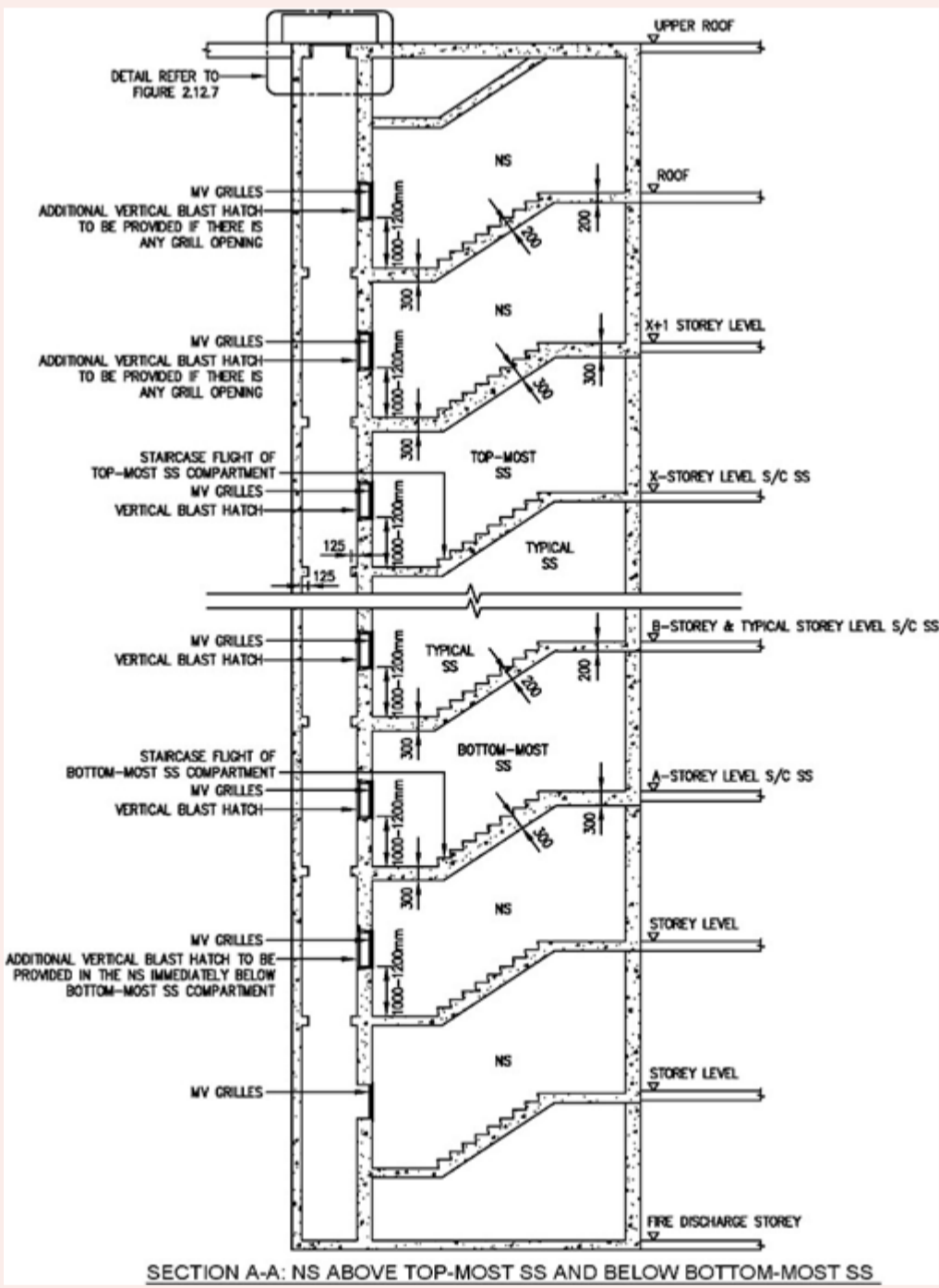
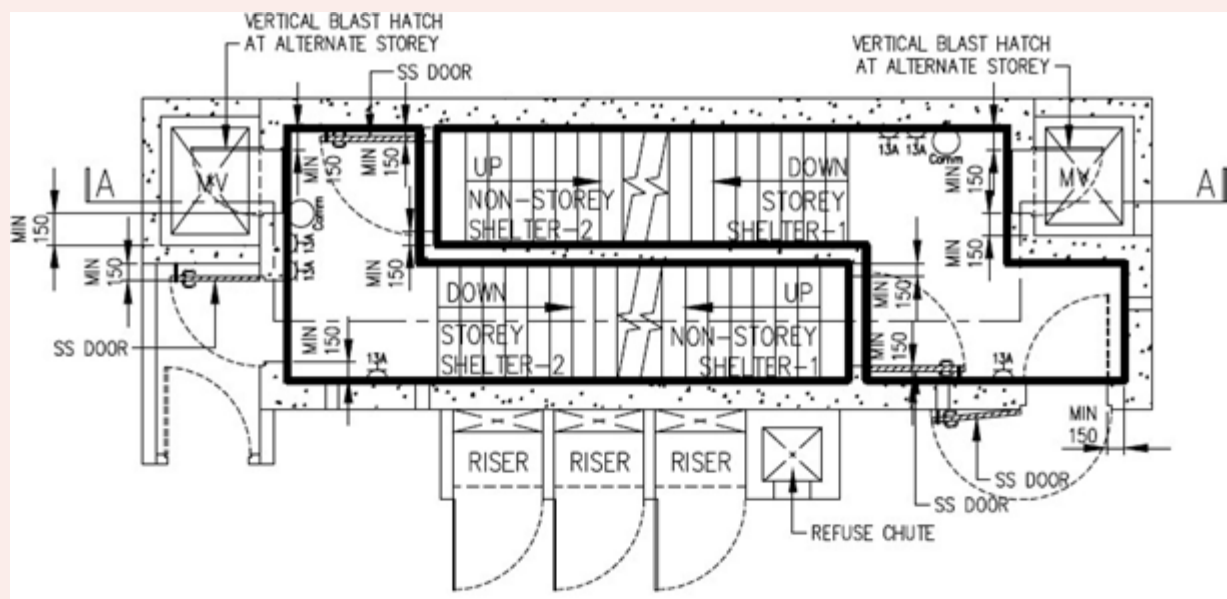
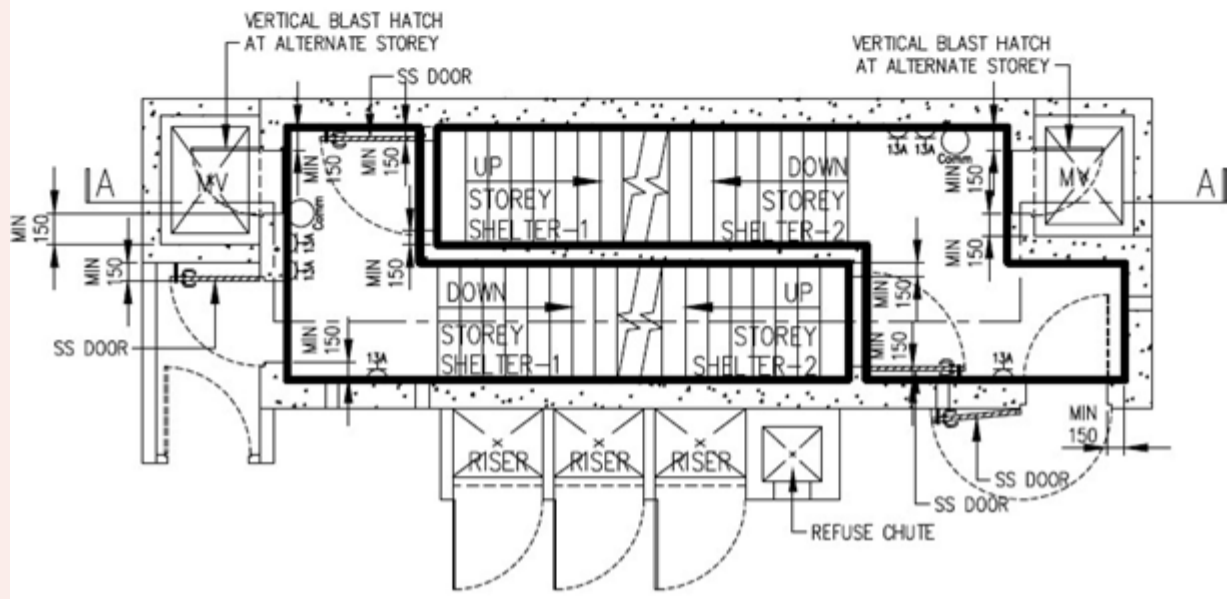

FIGURE 2.12.2(j): SCISSOR S/C SS COMPARTMENT PLAN



TOP-MOST COMPARTMENT PLAN FOR SCISSOR STAIRCASE STOREY SHELTER



TYPICAL STOREY COMPARTMENT PLAN FOR SCISSOR STAIRCASE STOREY SHELTER

FIGURE 2.12.2(k): SECTION OF SCISSOR S/C SS COMPARTMENT

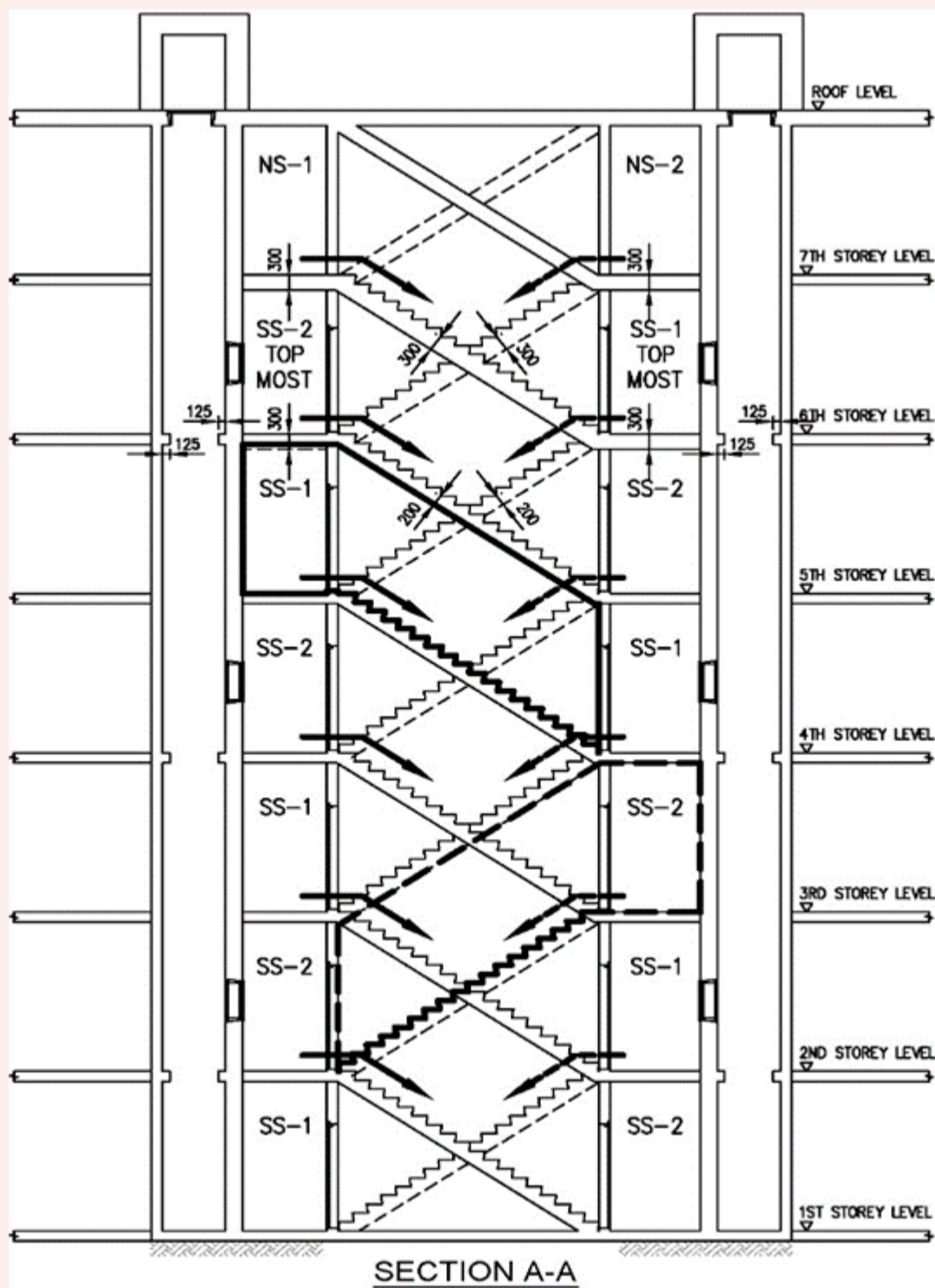

SECTION A-A

e. No other openings shall be permitted in each S/C SS compartment except for the two ventilation sleeves, which are placed in closed position, and the required MV opening.

2.12.2 S/C SS Doors at Shelter Entrance

a. At every storey, one SS door with removable door kerb, is to be provided at the shelter entrance and shall be kept in the open position during peacetime. Refer to FIGURE 2.12.2(b), 2.12.2(d) to 2.12.2(k). A door holder shall be provided to hold the internal SS door in open position. Refer to FIGURE 2.12.2(l). As this SS door swing against the direction of exit travel, it shall be not doubled up as the peacetime fire-rated door.

Figures & Tables

FIGURE 2.12.2(b): SS WITH NS ABOVE TOP-MOST SS COMPARTMENT, INTERMEDIATE SS COMPARTMENT AND SS WITH NS BELOW BOTTOM-MOST SS COMPARTMENT

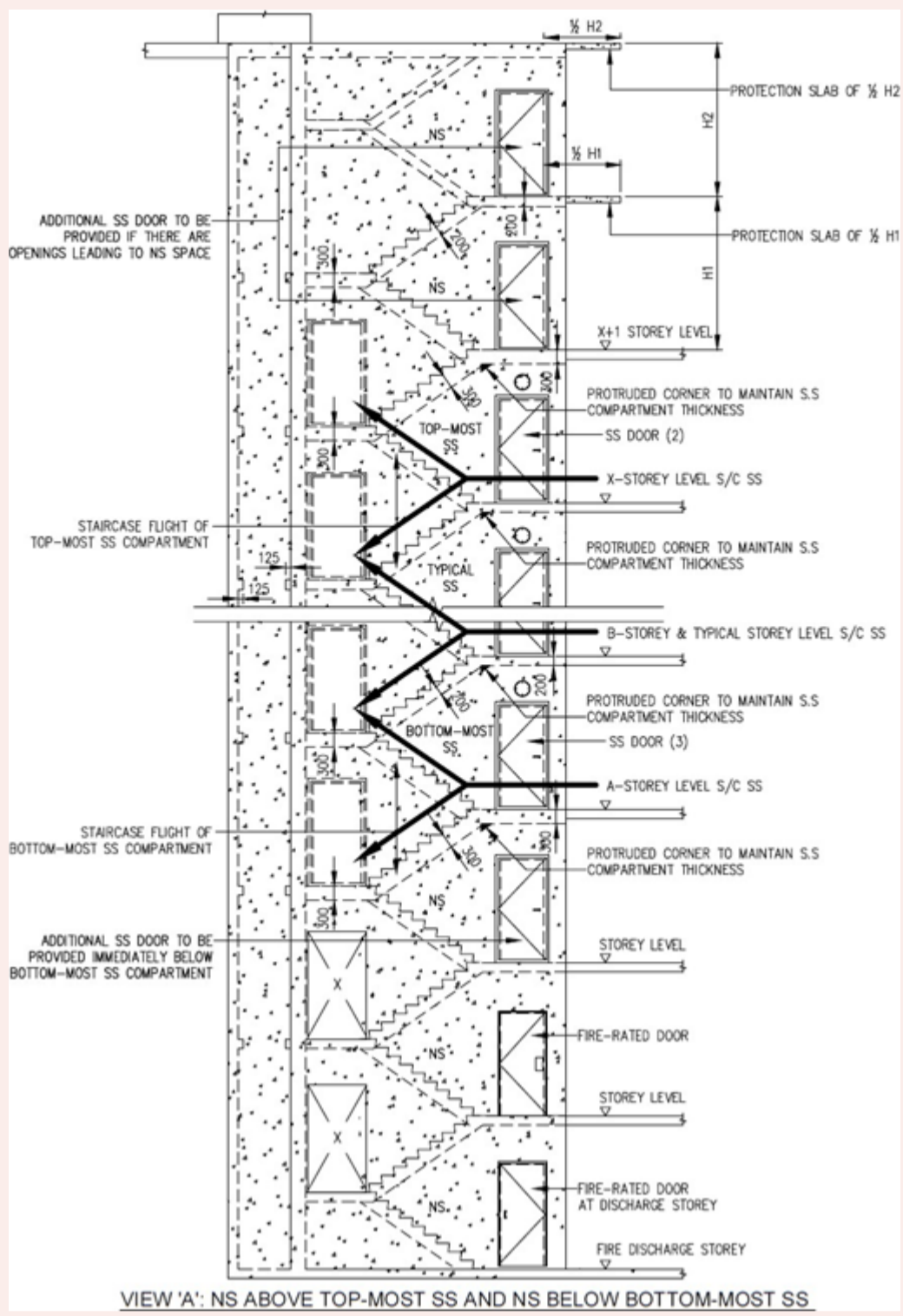

VIEW 'A': NS ABOVE TOP-MOST SS AND NS BELOW BOTTOM-MOST SS.

FIGURE 2.12.2(d): SS WITH NS ABOVE TOP-MOST SS COMPARTMENT, INTERMEDIATE SS COMPARTMENT AND SS WITH NS BELOW BOTTOM-MOST SS COMPARTMENT

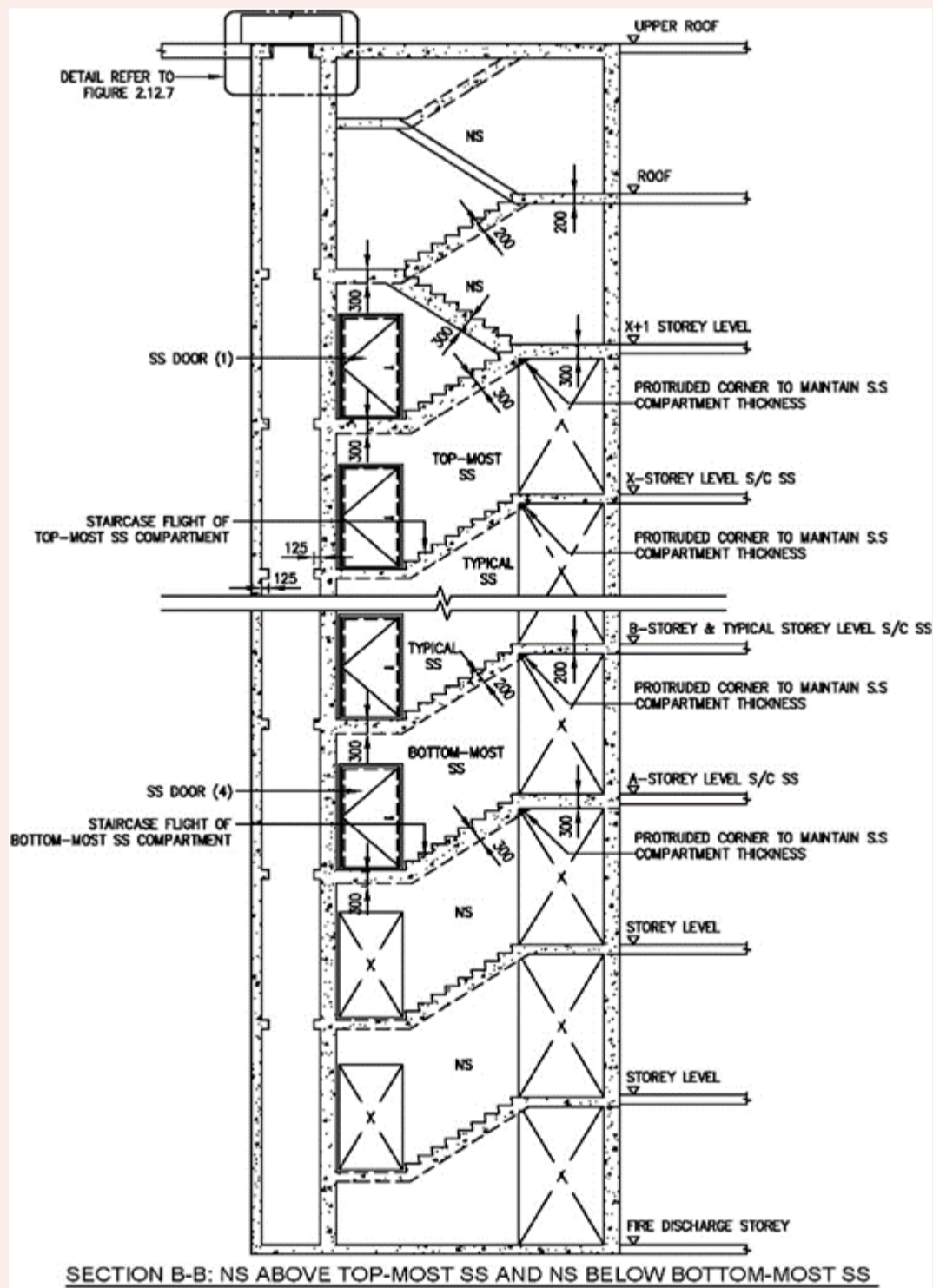

SECTION B-B: NS ABOVE TOP-MOST SS AND NS BELOW BOTTOM-MOST SS.

FIGURE 2.12.2(e): SS WITH NS ABOVE TOP-MOST SS COMPARTMENT, INTERMEDIATE SS COMPARTMENT AND SS WITH NS BELOW BOTTOM-MOST SS COMPARTMENT

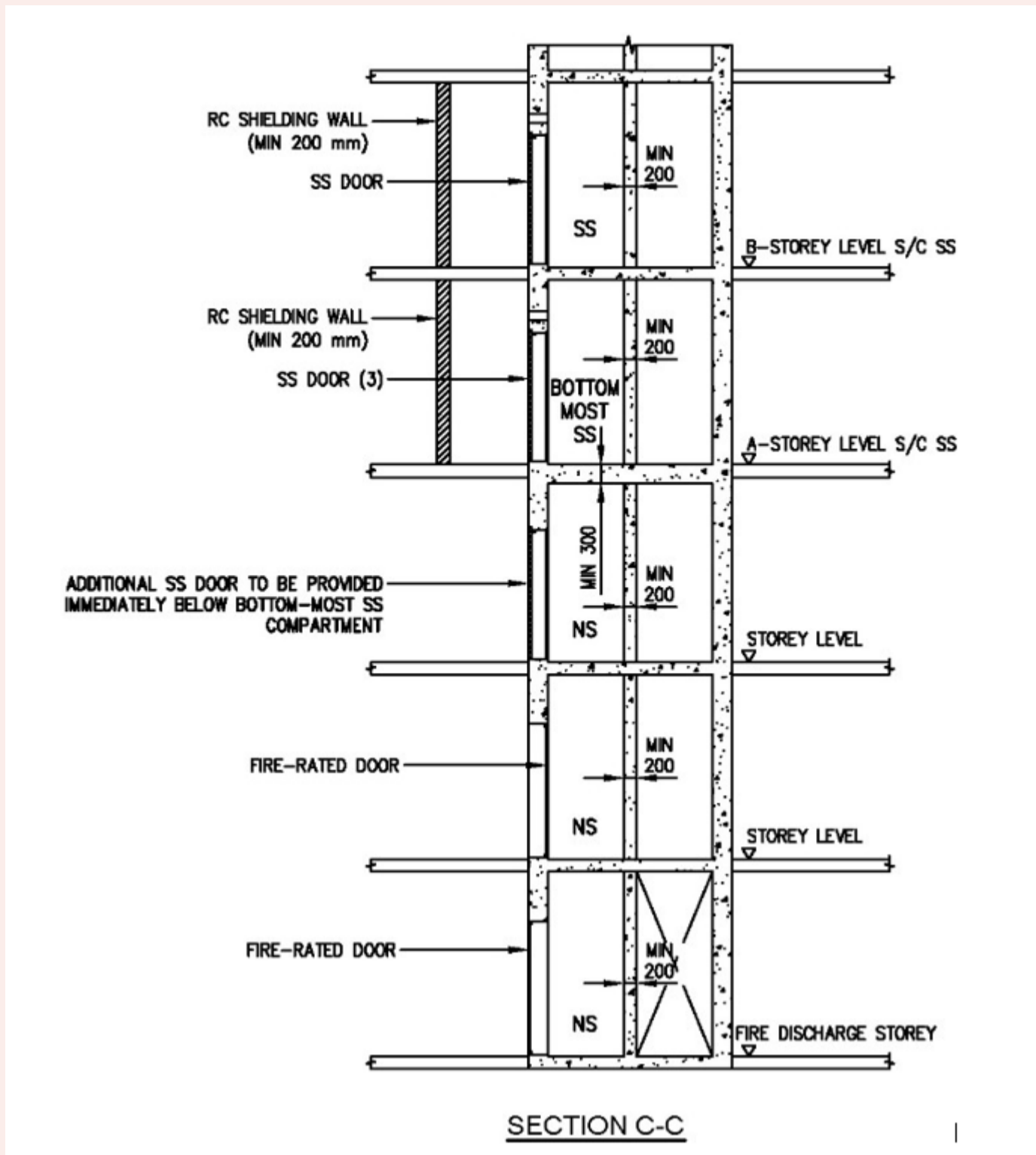

FIGURE 2.12.2(f): DETAIL PLAN OF S/C SS AND NS AT FIRE DISCHARGE STOREY

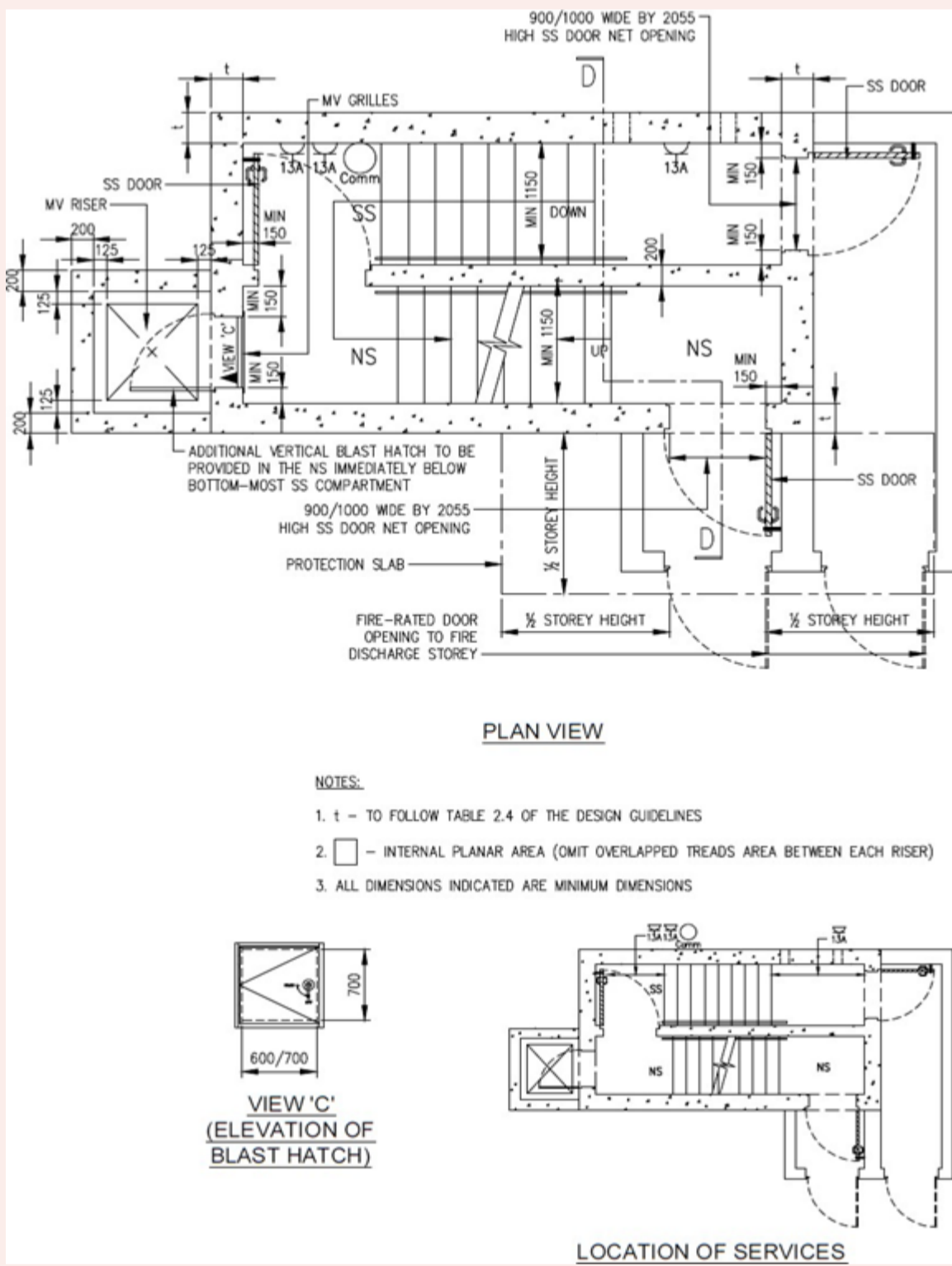

FIGURE 2.12.2(g): DETAIL PLAN OF NS IMMEDIATELY BELOW SS AT FIRE DISCHARGE STOREY

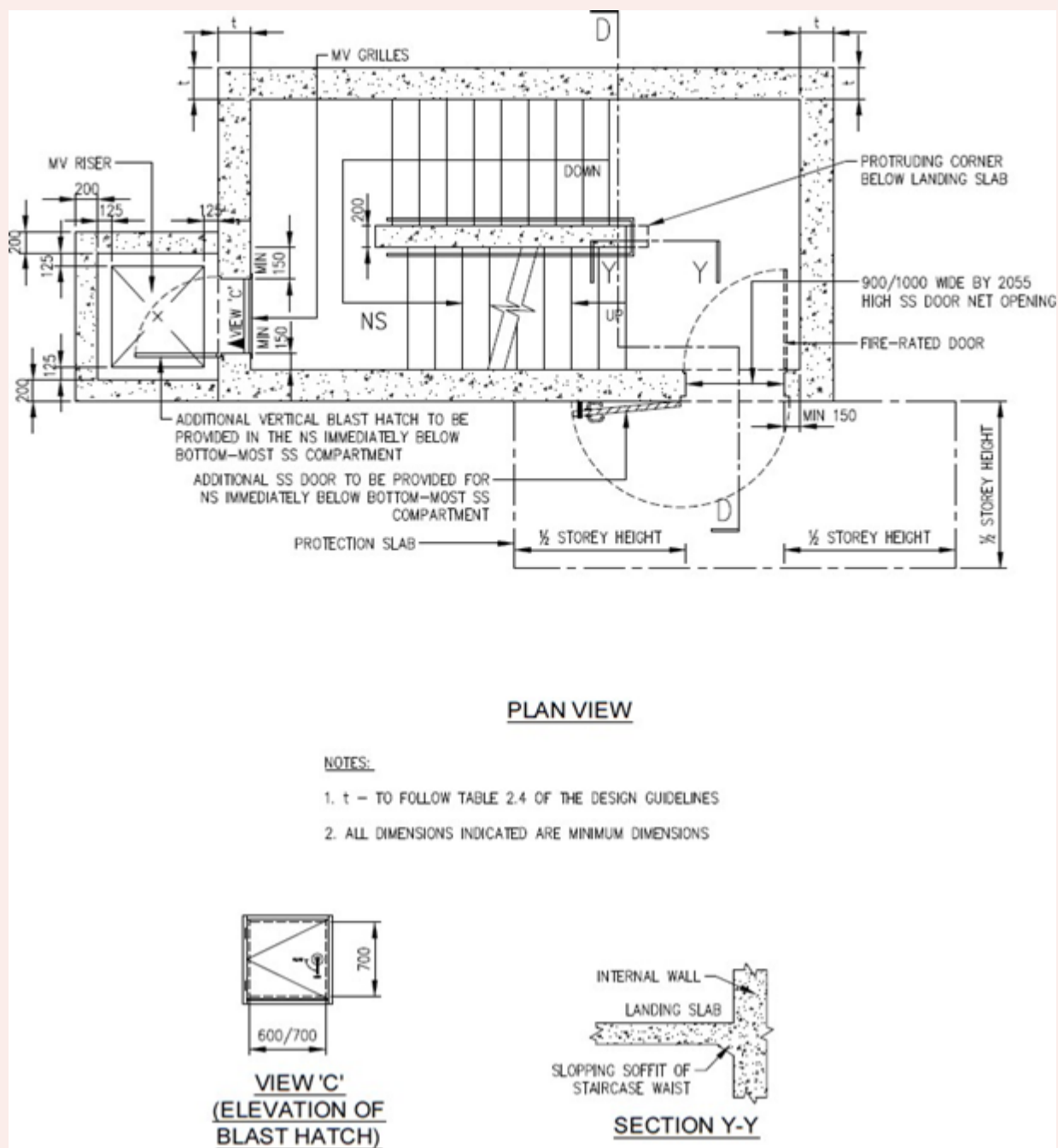

FIGURE 2.12.2(h): DETAIL SECTION OF SS AND NS AT FIRE DISCHARGE STOREY

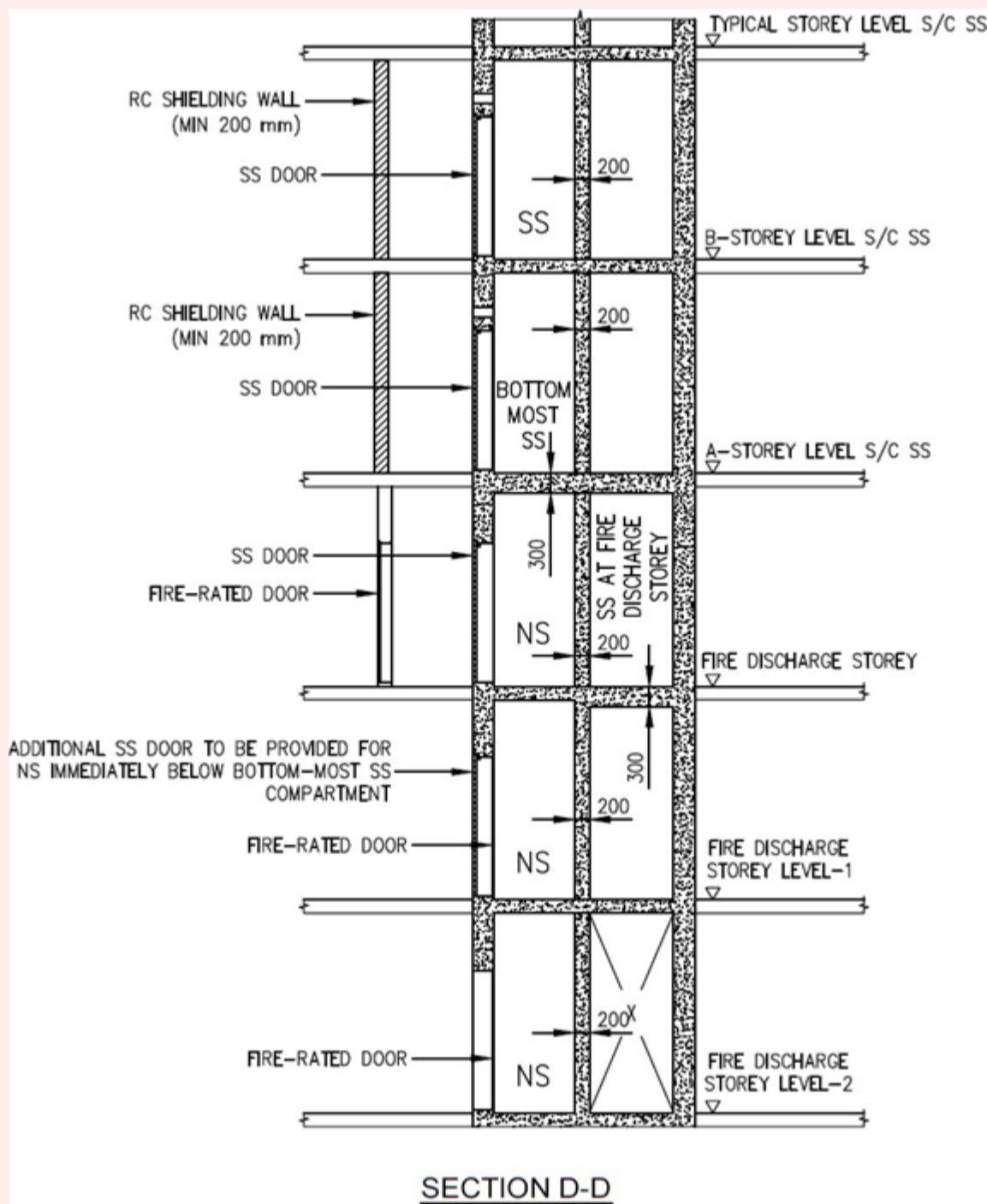

FIGURE 2.12.2(i): SS WITH NS COMPARTMENT WITH LAST BOTTOM-MOST SS DOOR ON 300MM THICK INTERNAL WALL

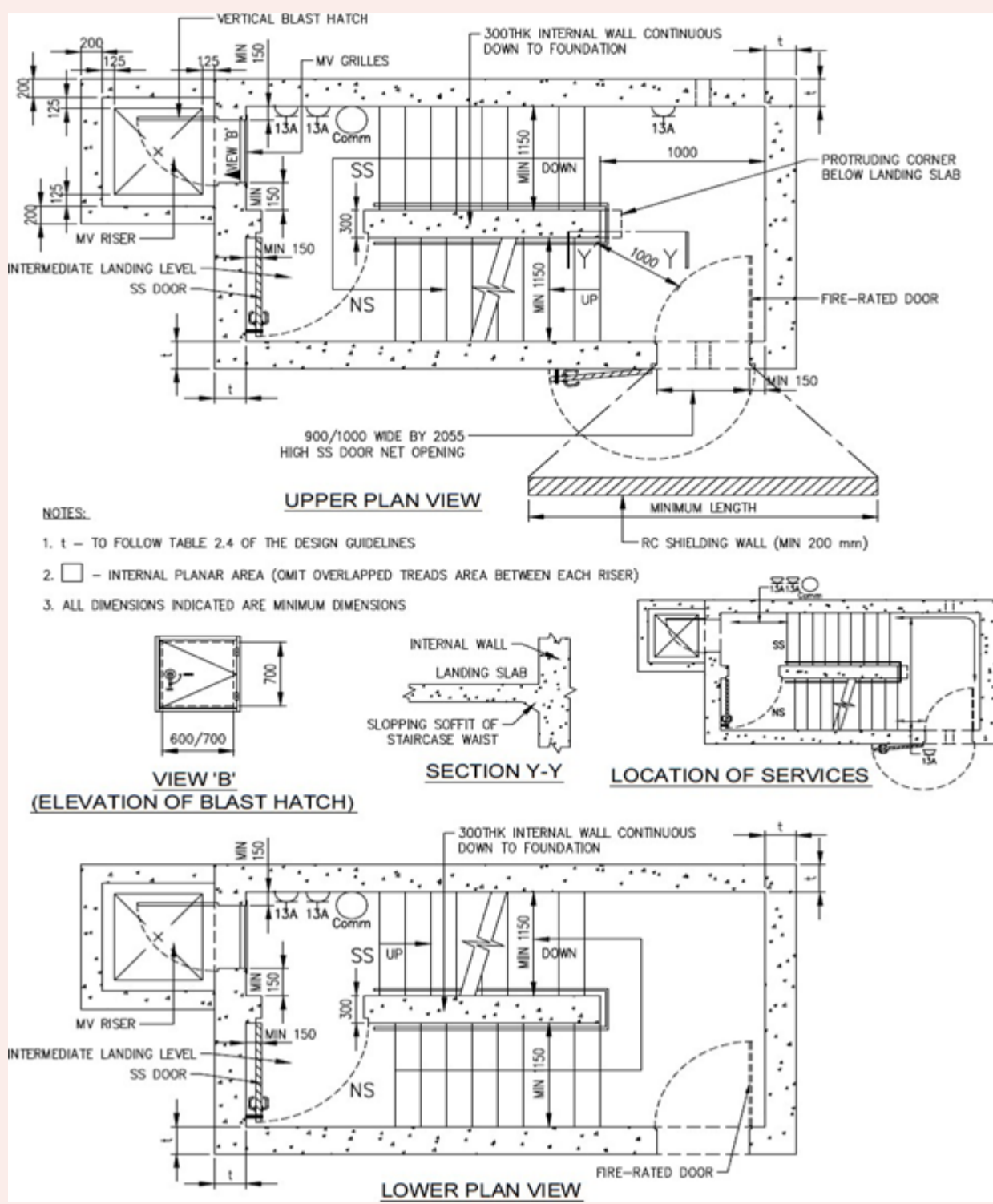

FIGURE 2.12.2(j): SCISSOR S/C SS COMPARTMENT PLAN

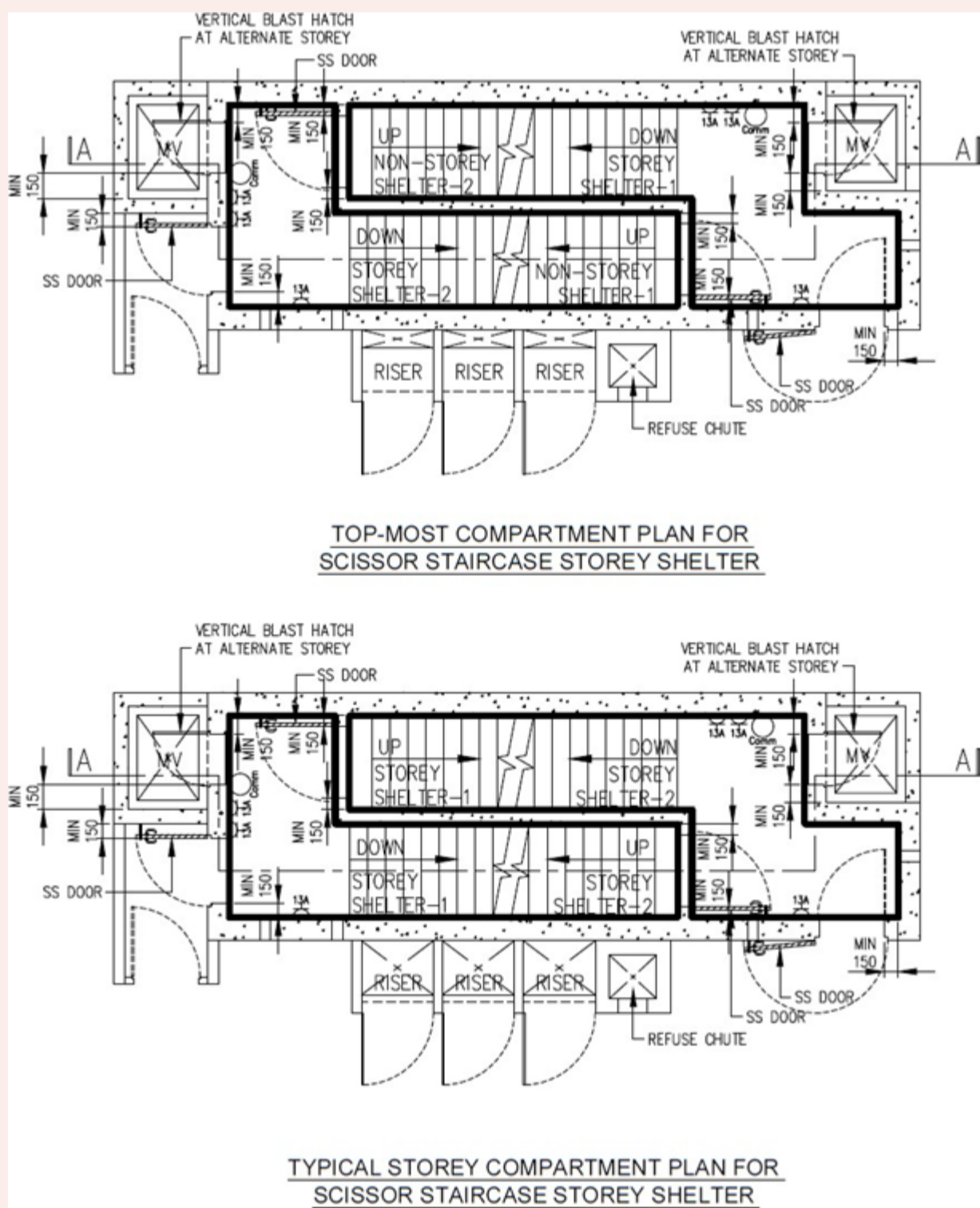

FIGURE 2.12.2(k): SECTION OF SCISSOR S/C SS COMPARTMENT

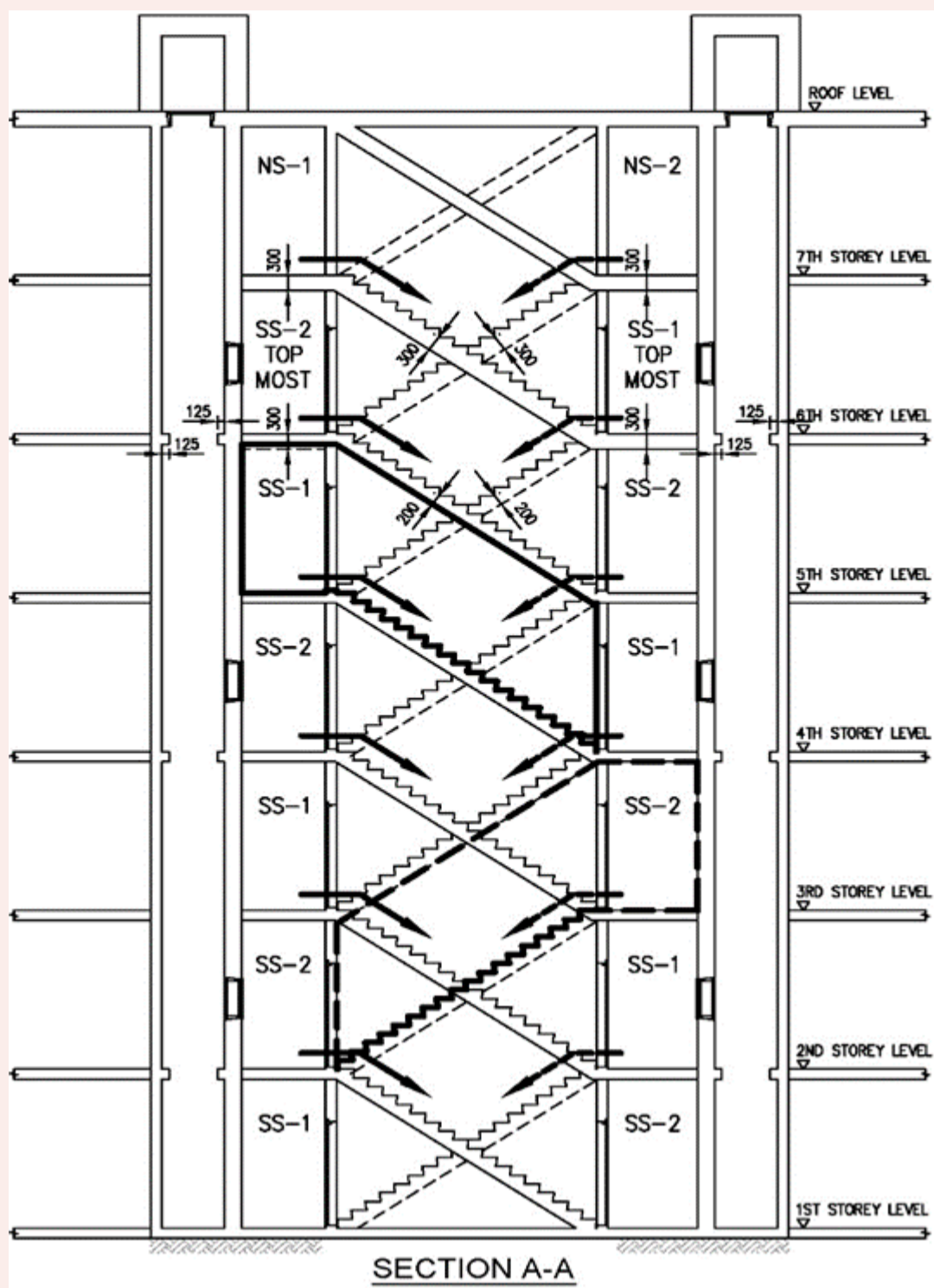
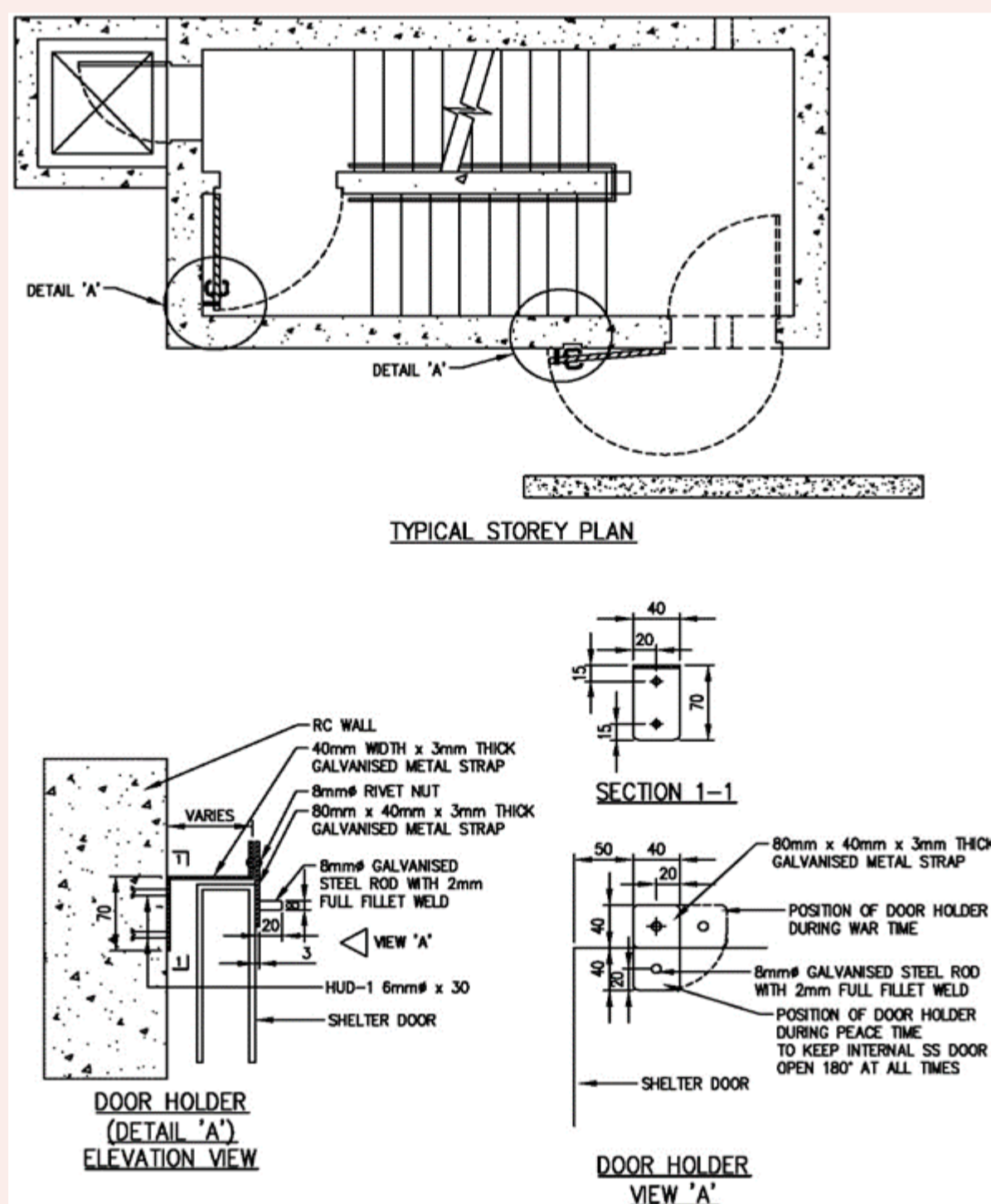

FIGURE 2.12.2(i): DETAIL OF SS DOOR HOLDER



b. Where the staircase leads to the roof level, an external SS door swinging outwards from the staircase, has to be provided at the staircase entrance. This external SS door shall also be permanently kept open during peacetime and shall be suitably protected from the weather if it is exposed to external space.

2.12.3 Internal S/C SS Wall and SS Door

a. Inside the S/C SS, there has to be a continuous reinforced concrete internal wall of minimum 200mm thickness running through the full height of the S/C SS tower. At every storey, one internal SS door swinging in the direction of exit travel, with removable door kerb, is to be provided either at the staircase entrance landing or at the intermediate landing. Refer to FIGURE 2.12.1(f), 2.12.2(b), 2.12.2(j) and 2.12.2(k). The SS door clear opening dimensions shall be:

- i. Door opening width - 1000mm..
- ii. Door opening height - 2055mm.

Figures & Tables

FIGURE 2.12.1(f): TYPICAL PLAN OF S/C SS COMPARTMENT

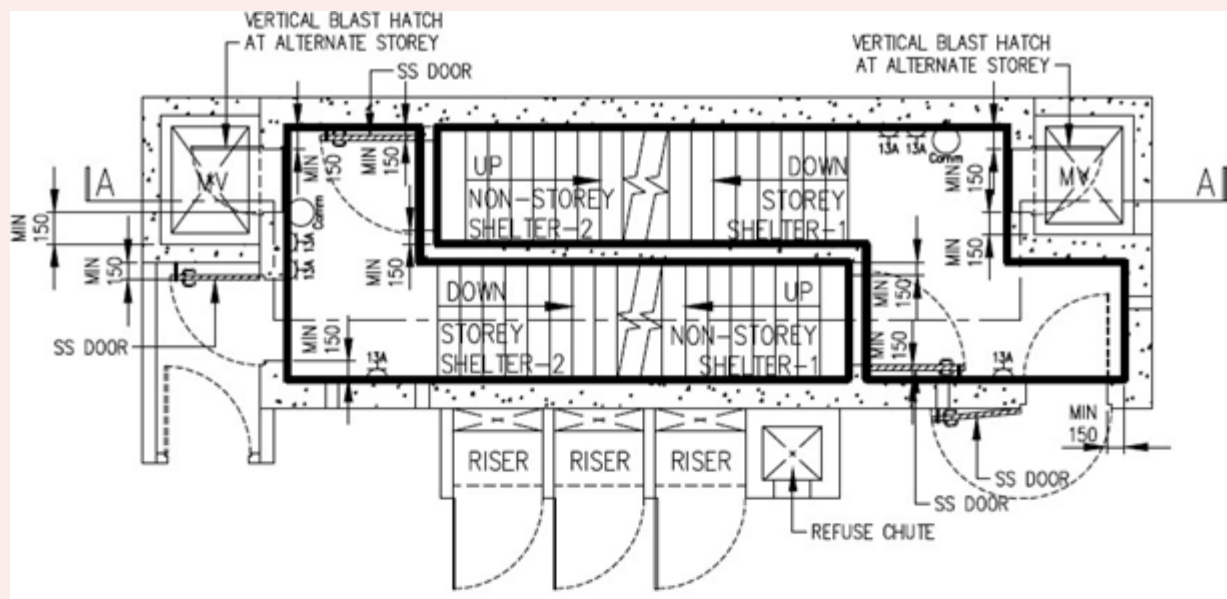

TOP-MOST COMPARTMENT PLAN FOR SCISSOR STAIRCASE STOREY SHELTER

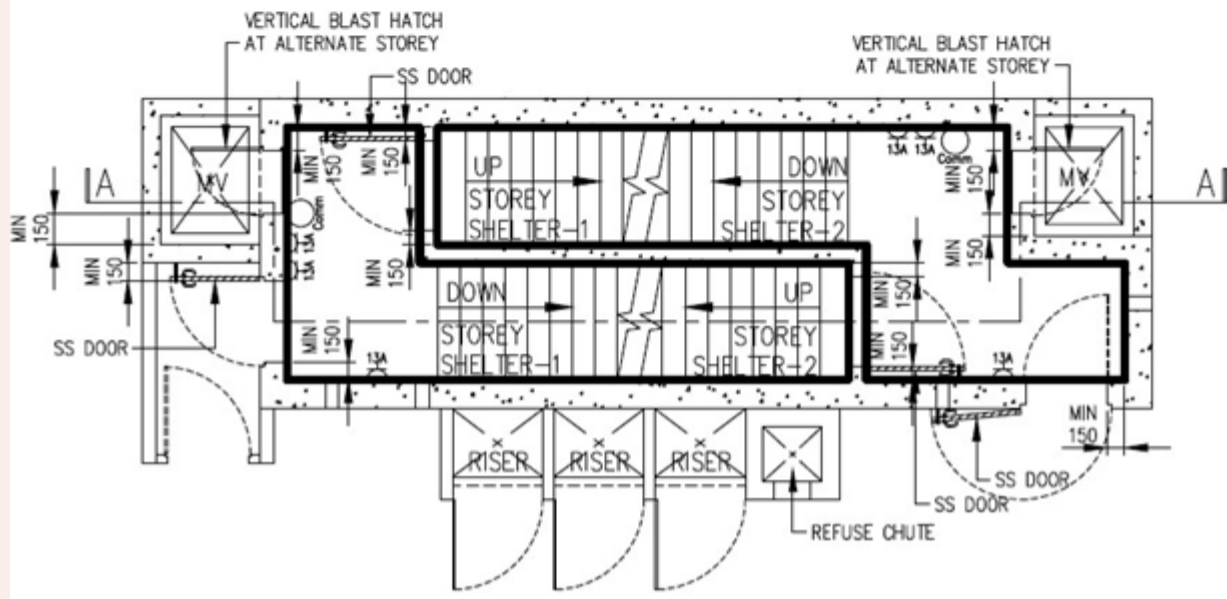

TYPICAL STOREY COMPARTMENT PLAN FOR SCISSOR STAIRCASE STOREY SHELTER

FIGURE 2.12.2(k): SECTION OF SCISSOR S/C SS COMPARTMENT

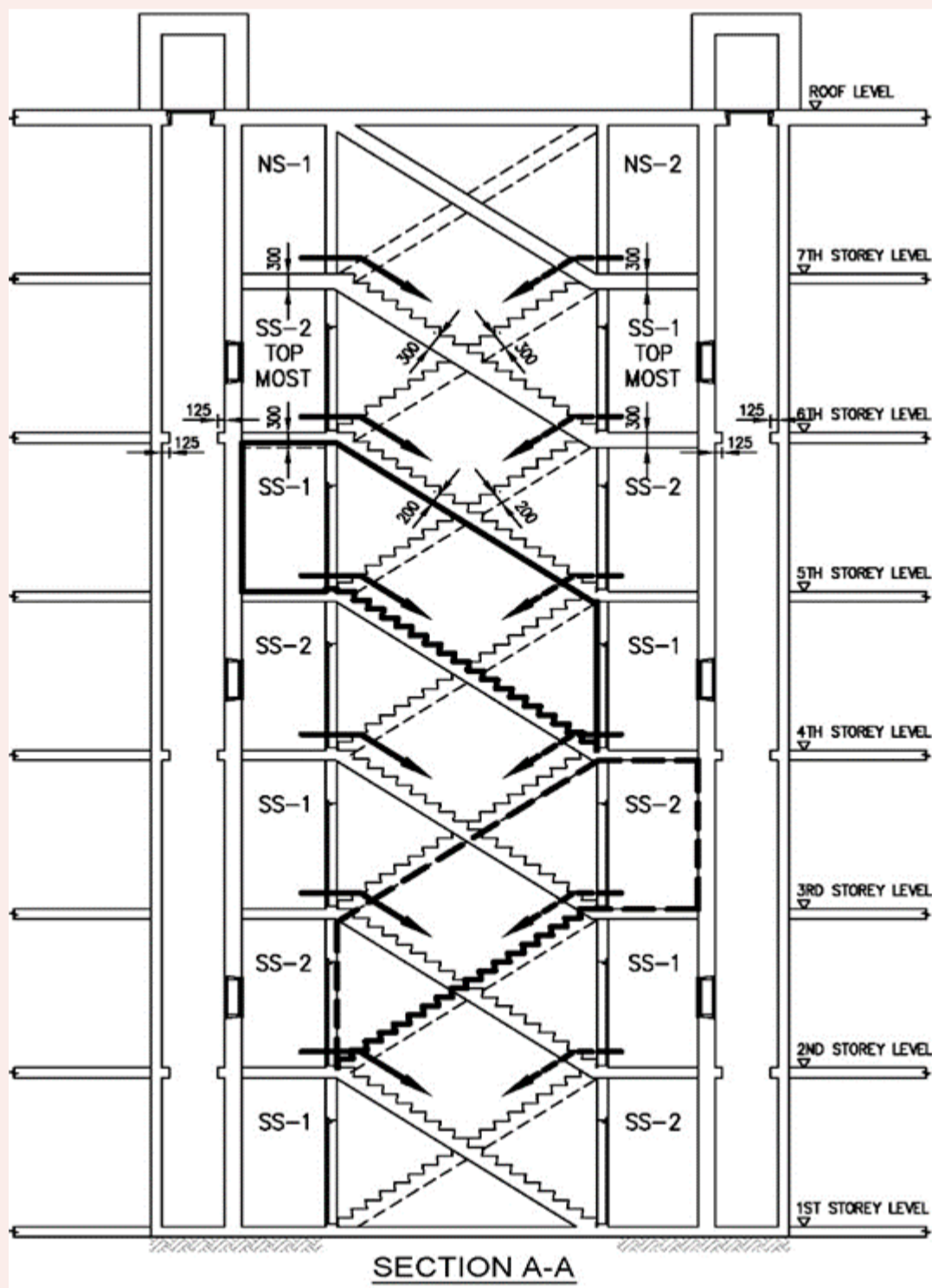

SECTION A-A

- b. This SS door is to be kept permanently open during peacetime. A door holder shall be provided to hold the internal SS door in open position. Refer to FIGURE 2.12.2(l).
- c. The RC wall and the internal SS door (when placed in closed position) serve to compartmentalise the staircase shaft into a series of staircase SS i.e. one SS compartment for each storey.

Figures & Tables

FIGURE 2.12.2(l): DETAIL OF SS DOOR HOLDER

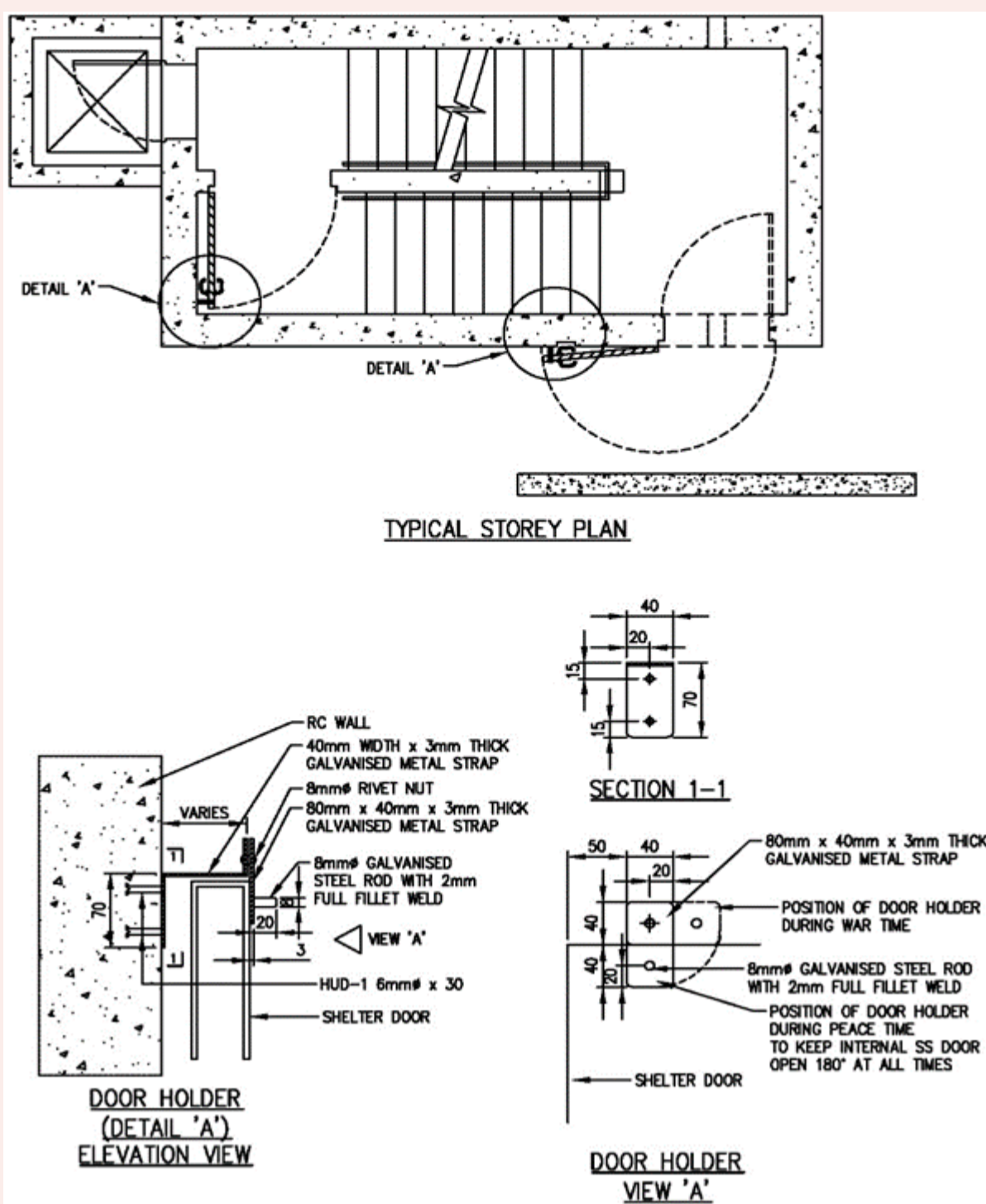

2.12.4 Shelter Compartment

a. S/C SS comprises one SS compartment each storey. Each shelter compartment shall be made up of one entrance SS door and 2 internal SS doors, i.e. one at each intermediate landing or main landing. Refer to FIGURE 2.12.1(f) and 2.12.2(b). For fire discharge level, refer to FIGURE 2.12.2(f) to 2.12.2(h).

Rationale

The design caters to the requirements in SCDF's Fire Code (refer to Fire Code Clause 2.3.3 for detailed requirement of internal/external exit staircases, discharge of exit staircases and minimum width and capacity). QP is reminded to factor in the difference in the building layout between the discharge and typical floor when designing S/C SS.

Figures & Tables

FIGURE 2.12.1(f): TYPICAL PLAN OF S/C SS COMPARTMENT

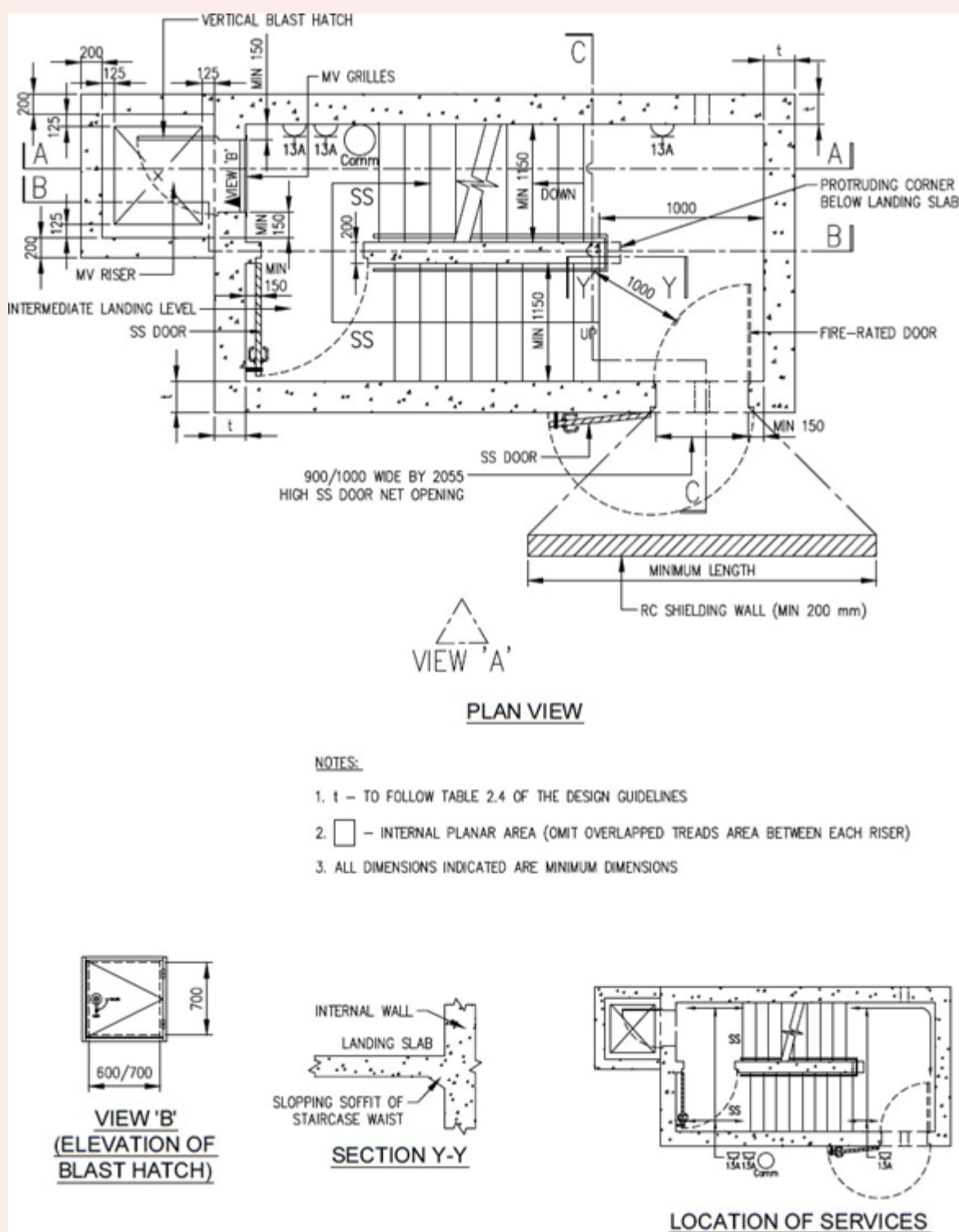
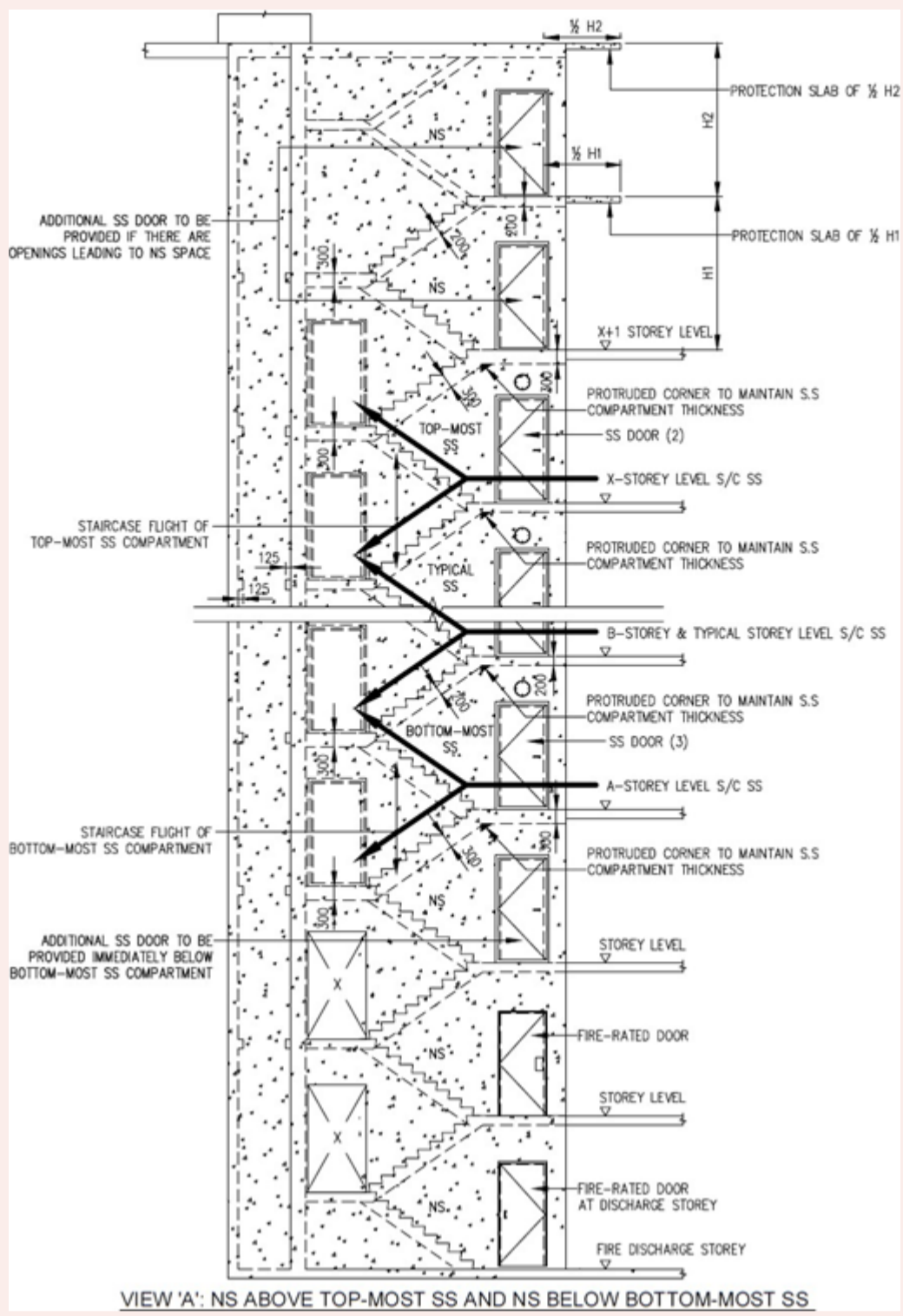

FIGURE 2.12.2(b): SS WITH NS ABOVE TOP-MOST SS COMPARTMENT, INTERMEDIATE SS COMPARTMENT AND SS WITH NS BELOW BOTTOM-MOST SS COMPARTMENT



VIEW 'A': NS ABOVE TOP-MOST SS AND NS BELOW BOTTOM-MOST SS

FIGURE 2.12.2(f): DETAIL PLAN OF S/C SS AND NS AT FIRE DISCHARGE STOREY

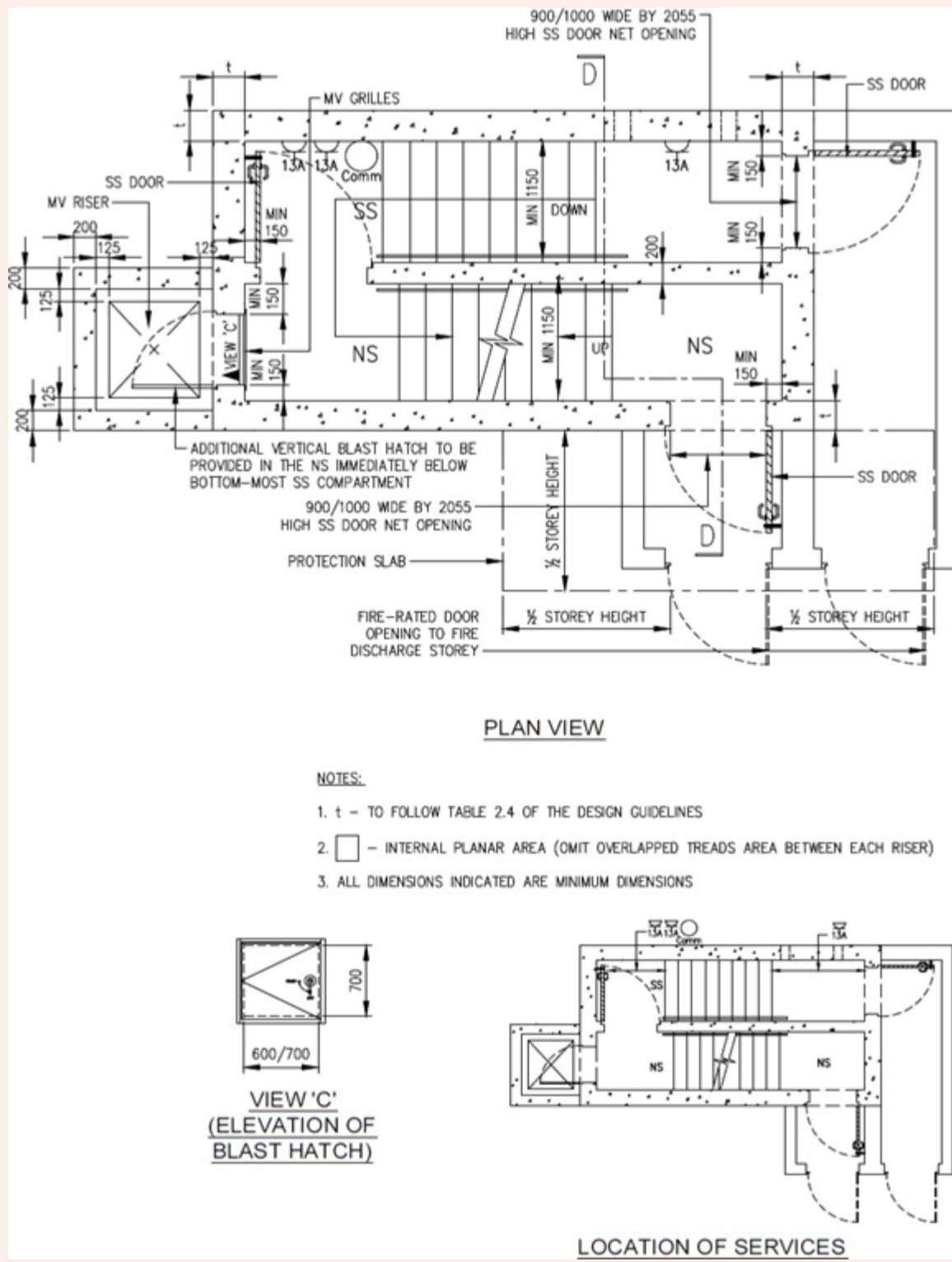

FIGURE 2.12.2(g): DETAIL PLAN OF NS IMMEDIATELY BELOW SS AT FIRE DISCHARGE STOREY

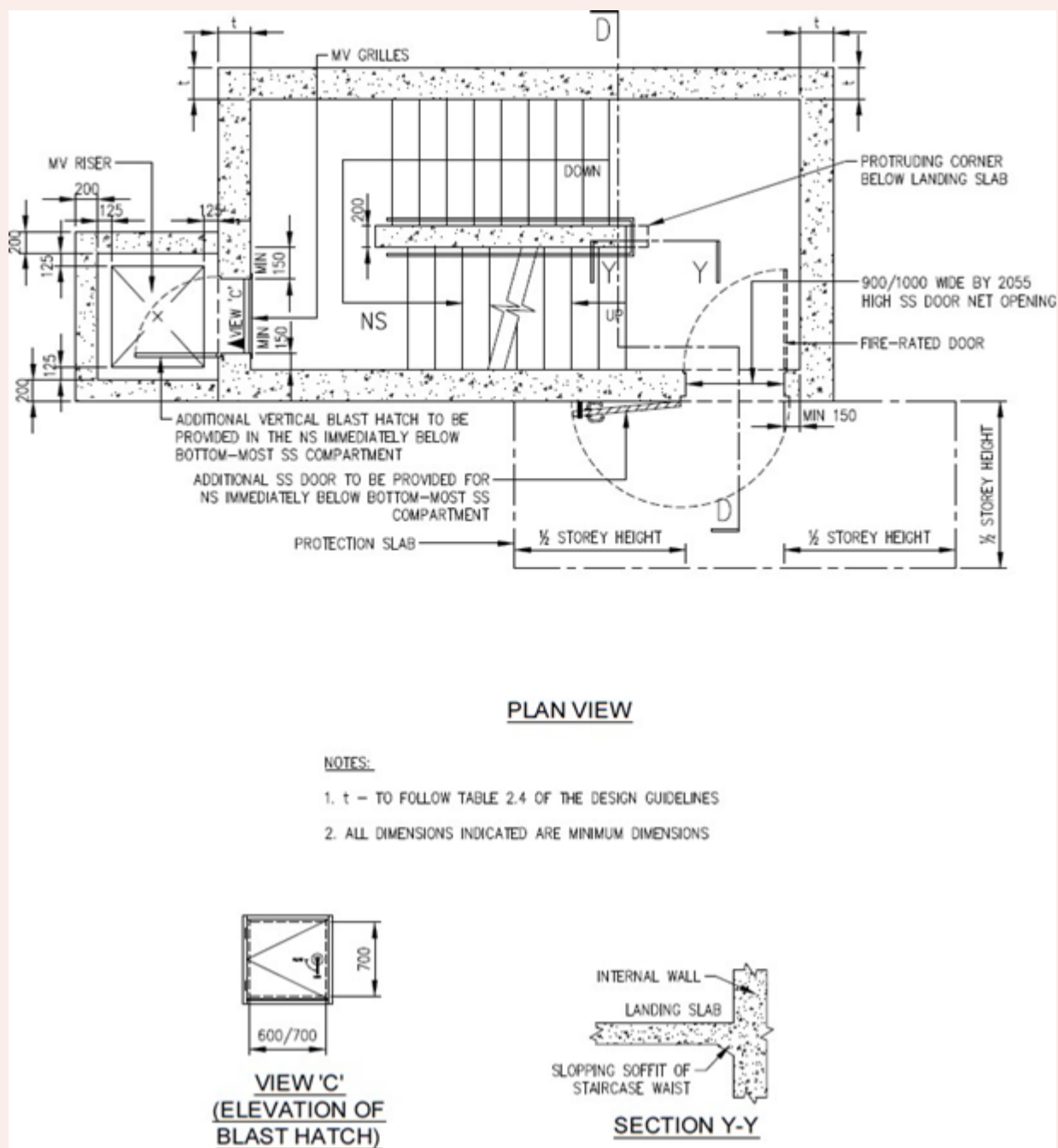
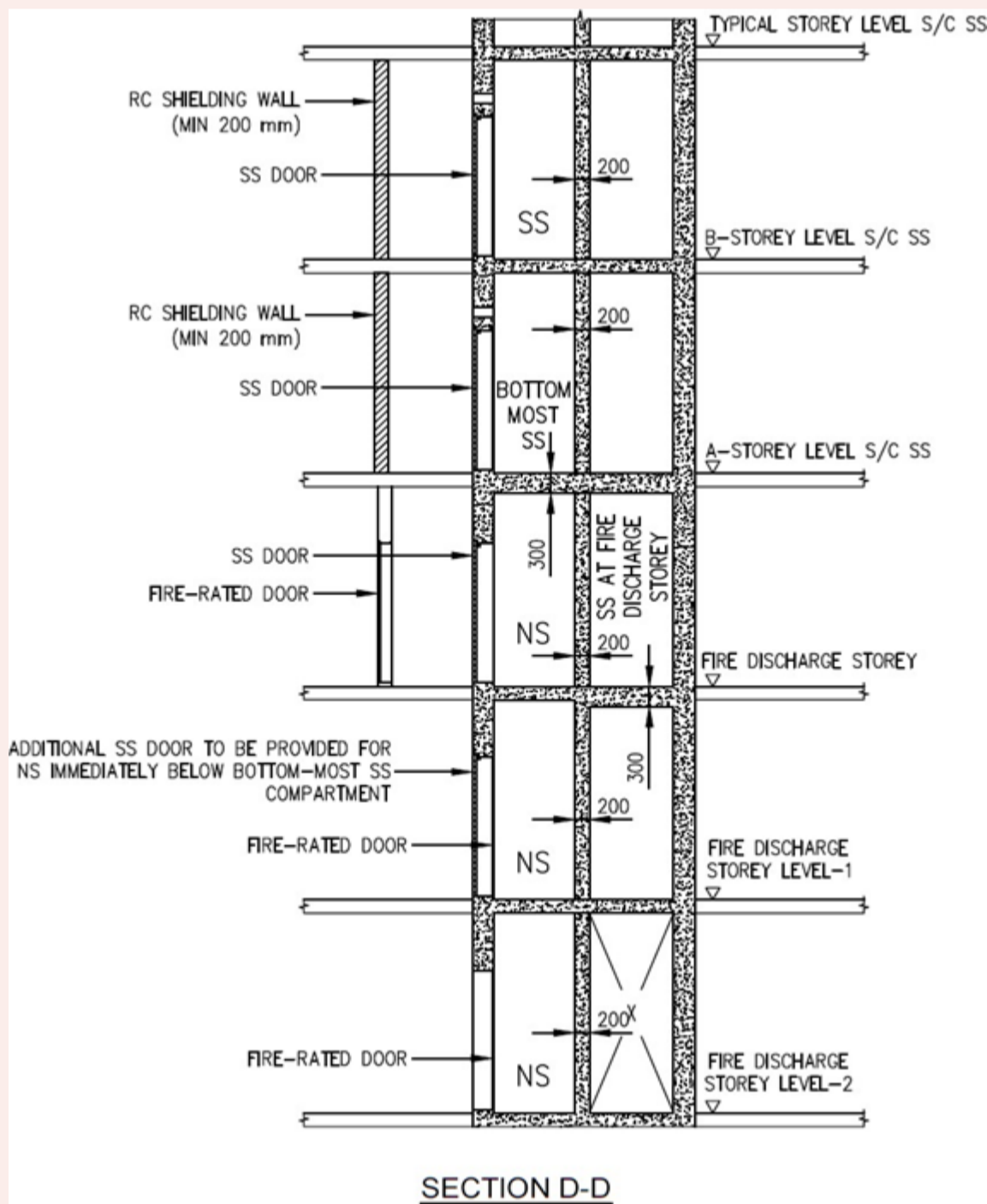

FIGURE 2.12.2(h): DETAIL SECTION OF SS AND NS AT FIRE DISCHARGE STOREY



b. Scissor S/C SS comprises two SS at each storey. Each SS compartment shall be made up of one entrance SS door and 2 internal SS doors. Refer to FIGURE 2.12.2(j) and 2.12.2(k). Signage shall be provided adjacent to each SS door entrance showing the designated dwelling units assigned to each shelter compartment.

Figures & Tables

FIGURE 2.12.2(j): SCISSOR S/C SS COMPARTMENT PLAN

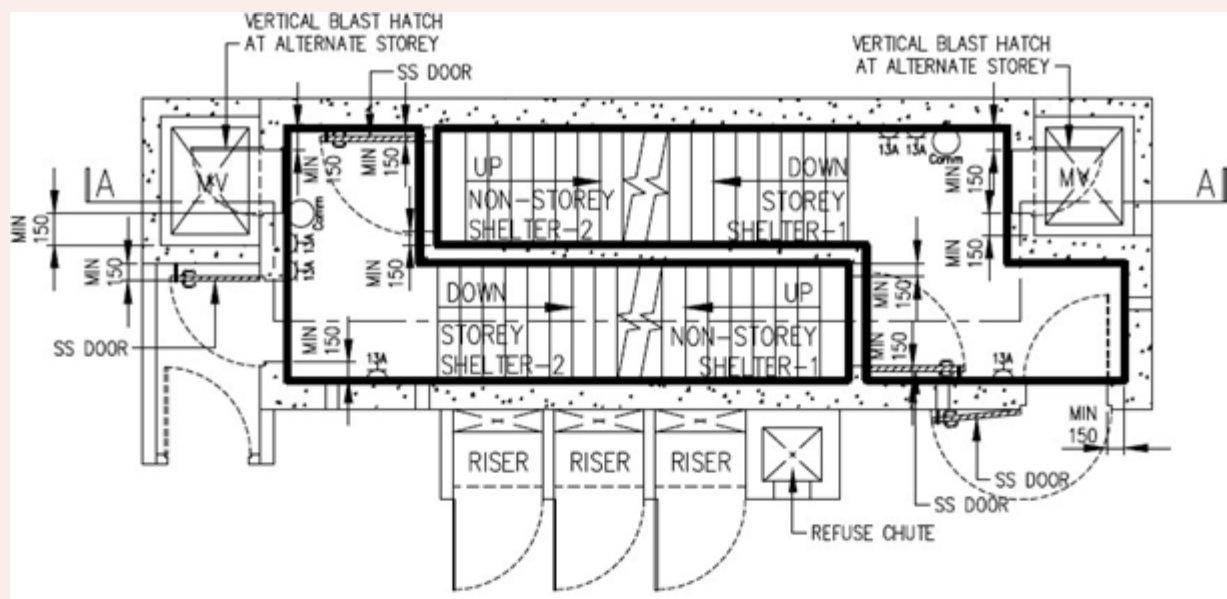

TOP-MOST COMPARTMENT PLAN FOR SCISSOR STAIRCASE STOREY SHELTER

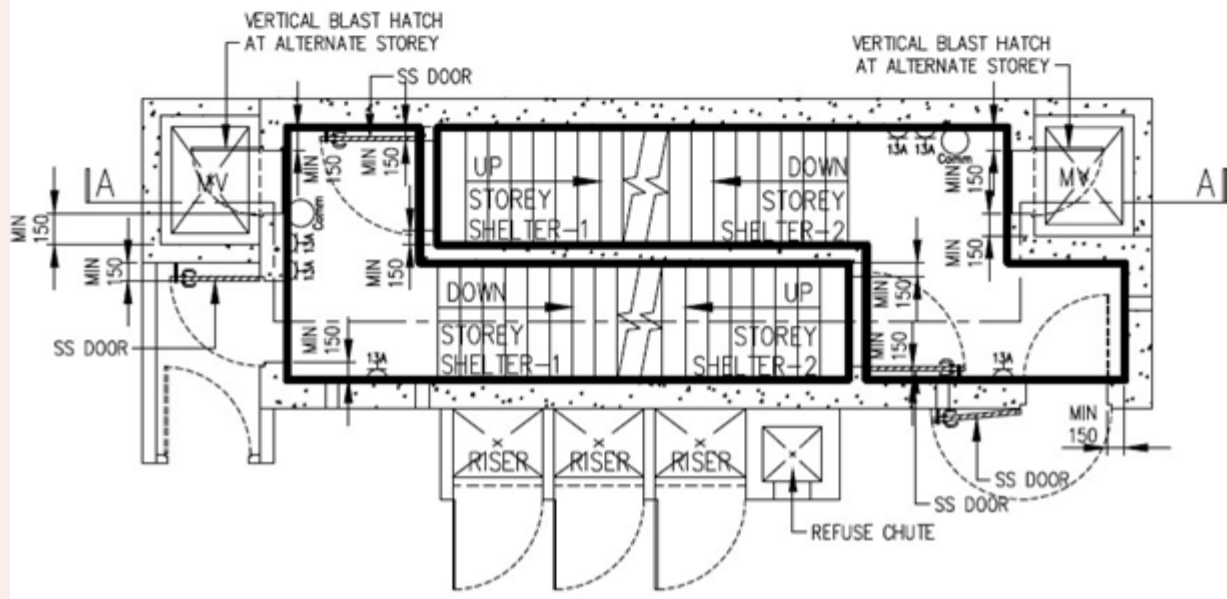

TYPICAL STOREY COMPARTMENT PLAN FOR SCISSOR STAIRCASE STOREY SHELTER

FIGURE 2.12.2(k): SECTION OF SCISSOR S/C SS COMPARTMENT

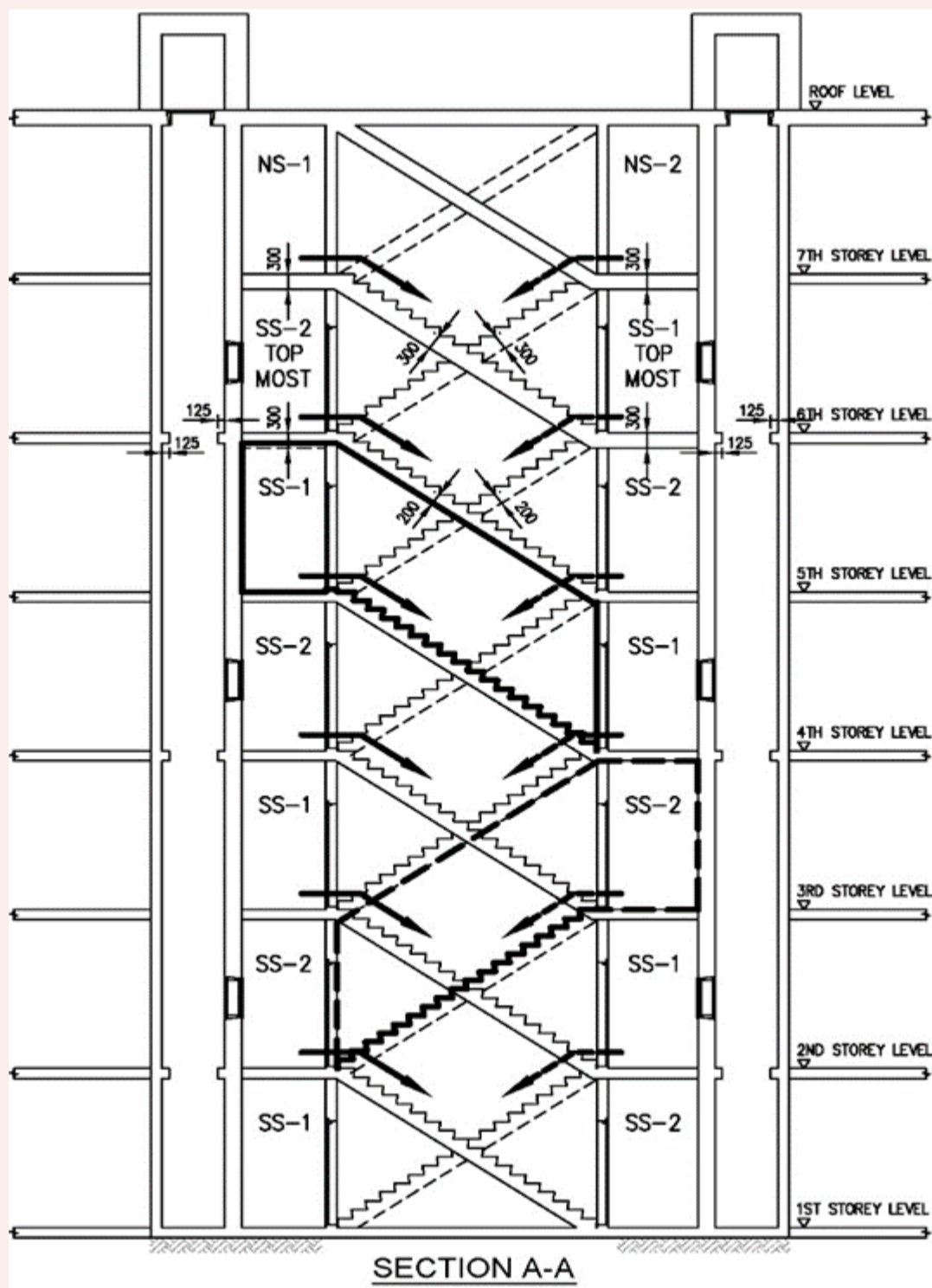

SECTION A-A

c. The slopping soffit of the staircase waist shall be continuous to meet the staircase. This shall include the part of slopping soffit projected from the 200mm thick internal wall as shown in FIGURE 2.12.1(f) and 2.12.2(d).

Figures & Tables

FIGURE 2.12.1(f): TYPICAL PLAN OF S/C SS COMPARTMENT

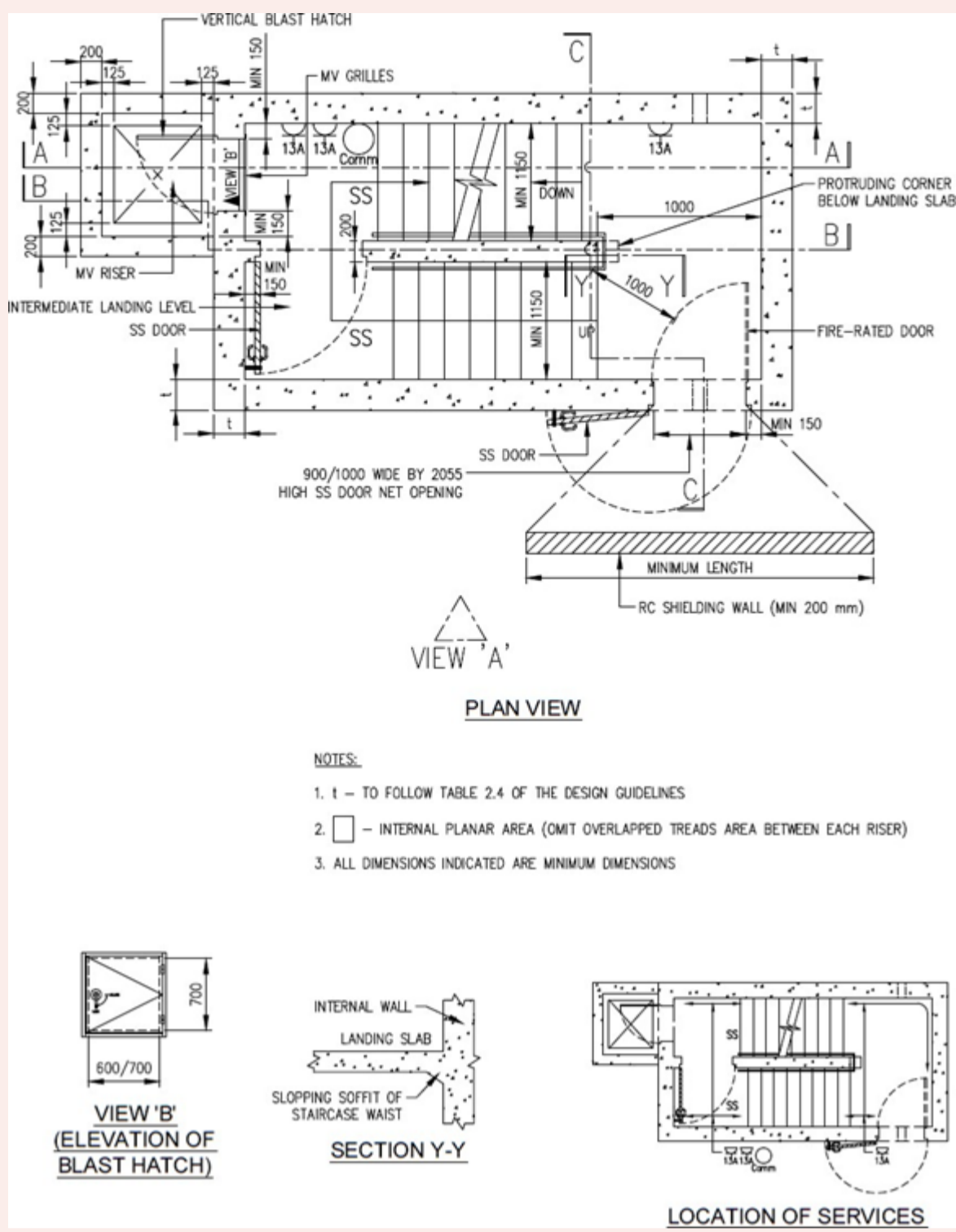
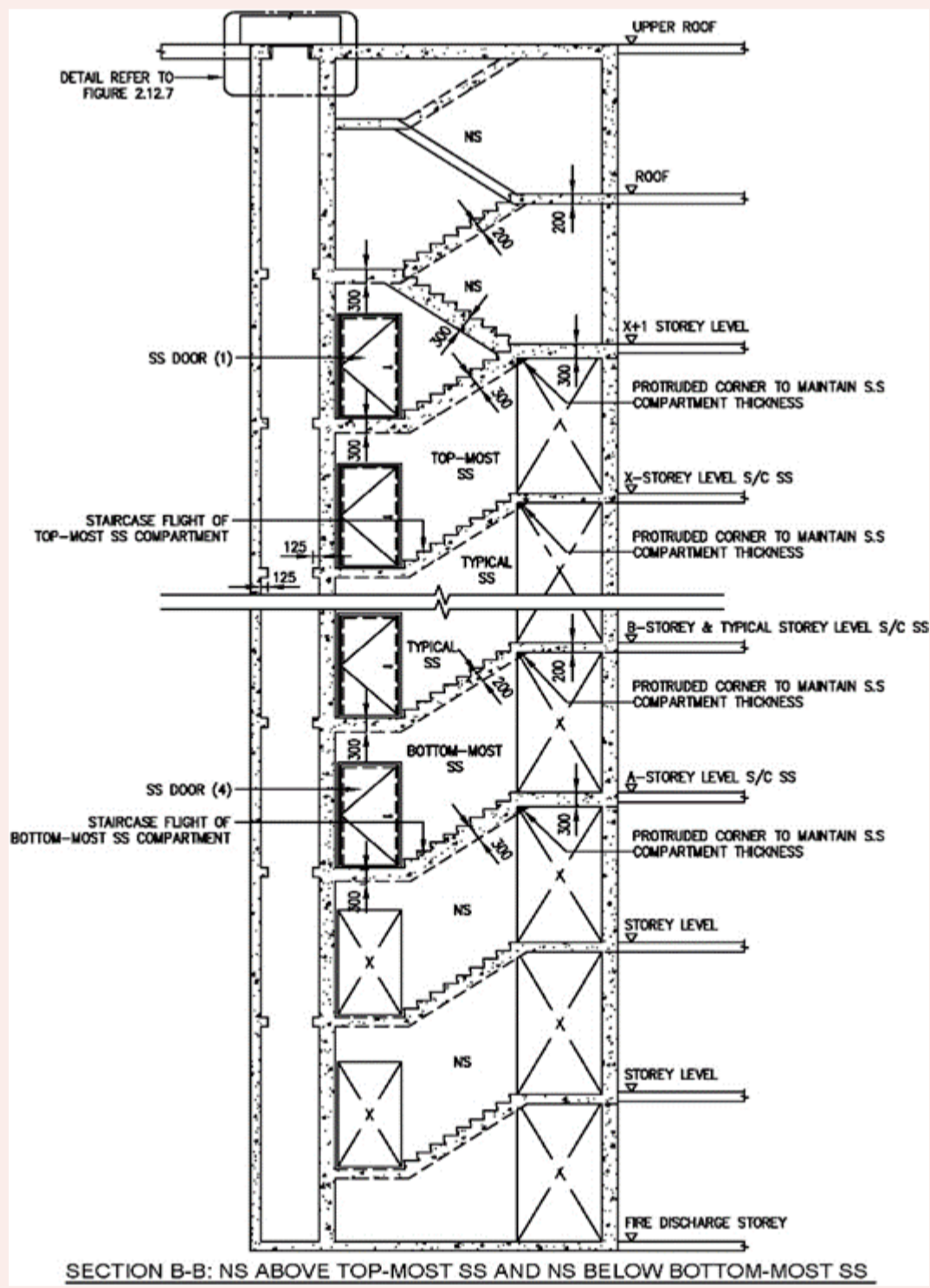

FIGURE 2.12.2(d): SS WITH NS ABOVE TOP-MOST SS COMPARTMENT, INTERMEDIATE SS COMPARTMENT AND SS WITH NS BELOW BOTTOM-MOST SS COMPARTMENT



2.12.5 Blast Hatch at MV Opening

a. There shall be a minimum 150mm reinforced concrete wall segment next to vertical edge of the blast hatch. Refer to FIGURE 2.5.3(c).

Figures & Tables

FIGURE 2.5.3(c): CONCRETE WALL SEGMENT AT S/C SS DOORS AND BLAST HATCH

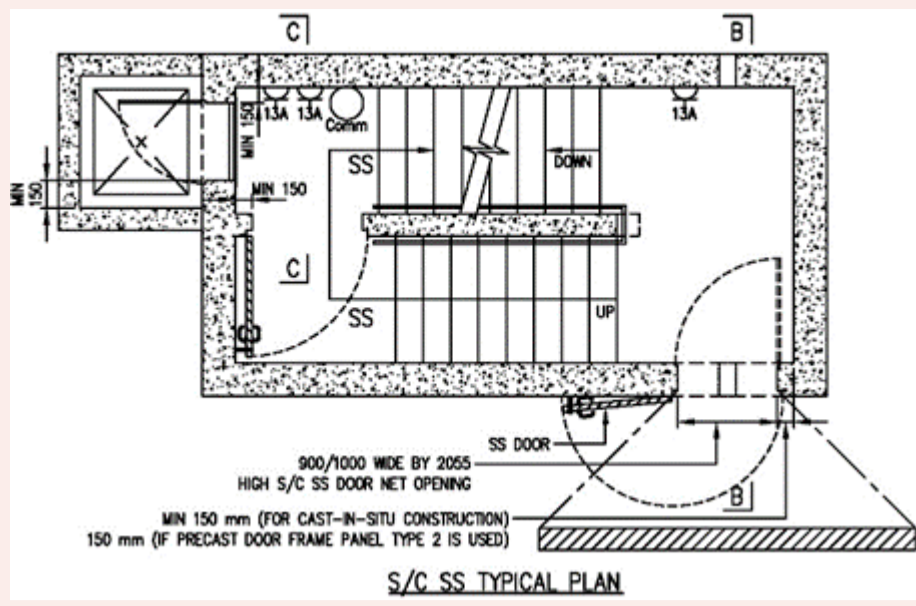

b. As the S/C SS and scissor S/C SS are to be mechanically ventilated, there would be vertical grille openings in S/C SS or scissor S/C SS wall. Where there are such openings (subject to the mechanical ventilation design), there shall be vertical blast hatch at the height of 1000mm-1200mm from the FFL, swung open into the MV riser, provided at these openings. Refer to FIGURE 2.12.2(c), 2.12.2(j) and 2.12.2(k). These openings shall be closed and made airtight by vertical blast hatches when the S/C SS or scissor S/C SS is converted for use as SS.

Figures & Tables

FIGURE 2.12.2(c): SS WITH NS ABOVE TOP-MOST SS COMPARTMENT, INTERMEDIATE SS COMPARTMENT AND SS WITH NS BELOW BOTTOM-MOST SS COMPARTMENT

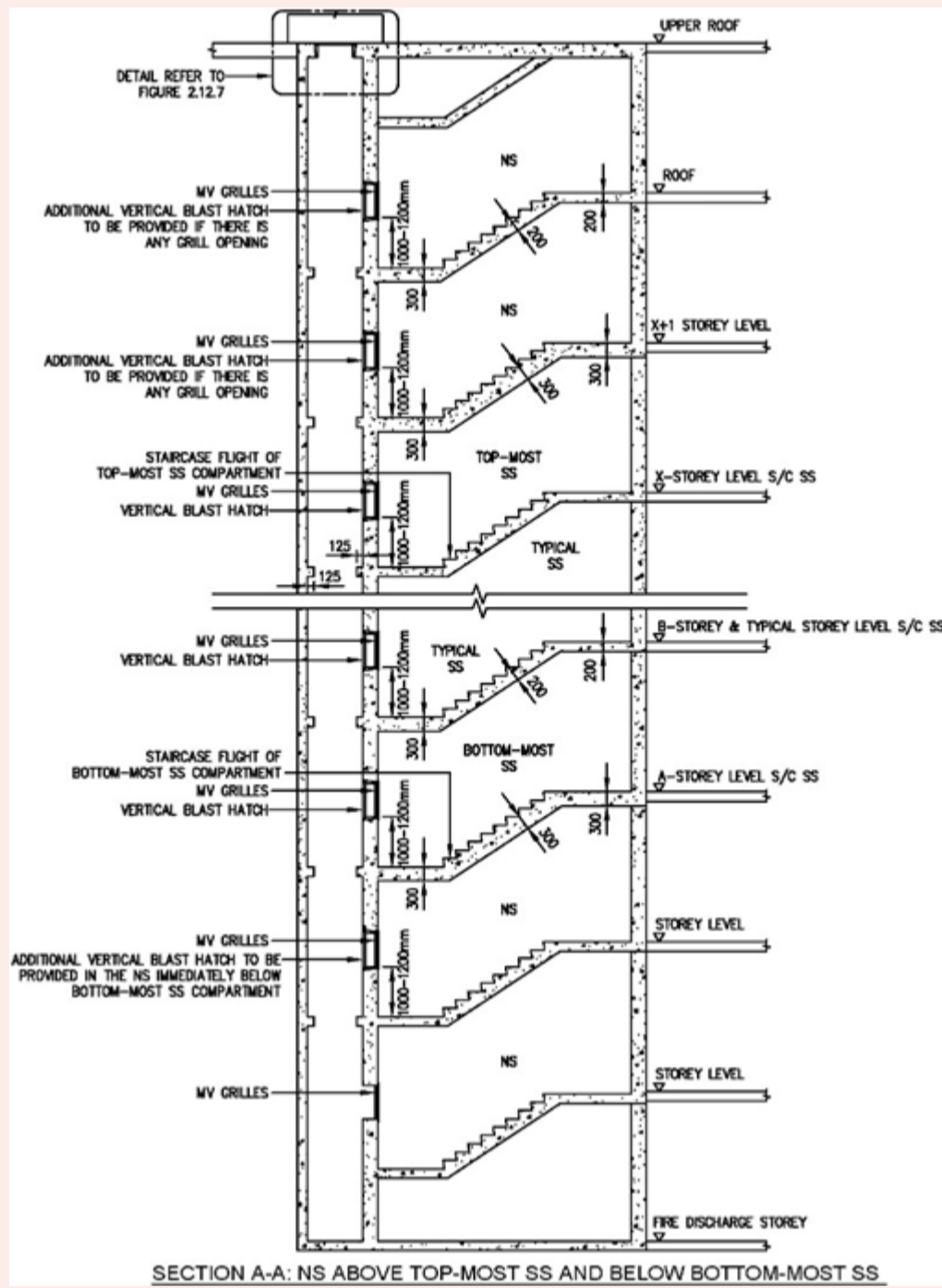

FIGURE 2.12.2(j): SCISSOR S/C SS COMPARTMENT PLAN

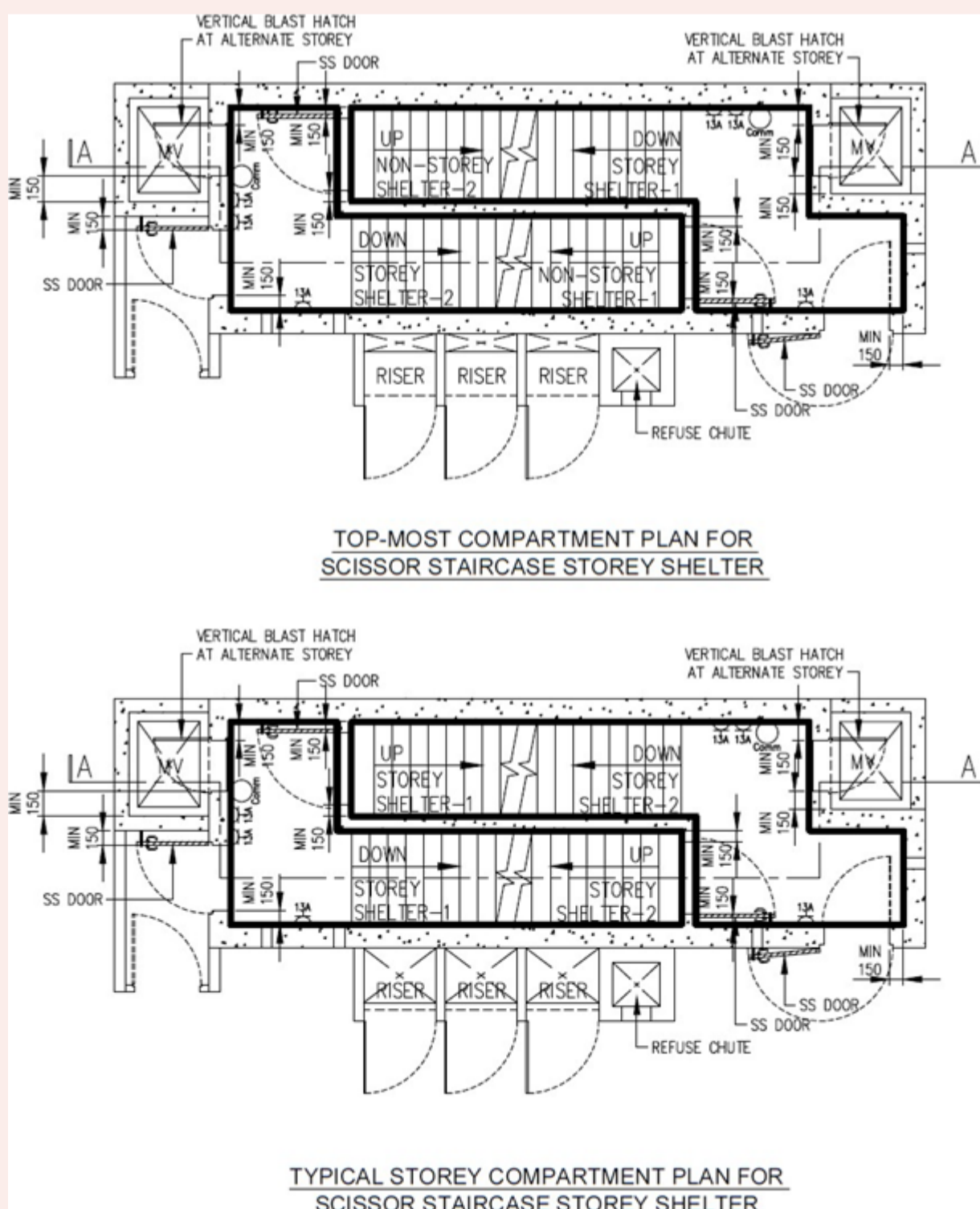
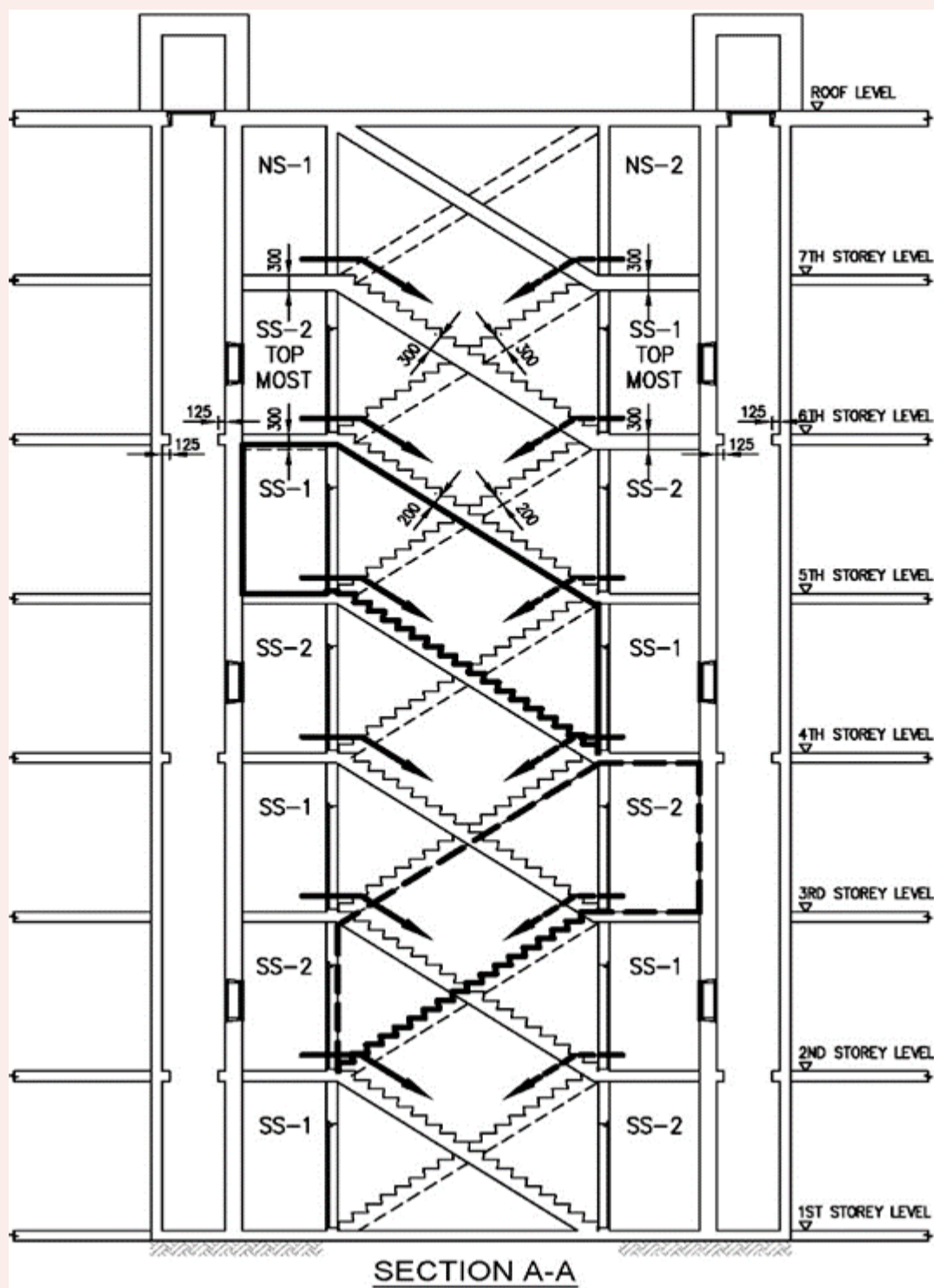

FIGURE 2.12.2(k): SECTION OF SCISSOR S/C SS COMPARTMENT



c. The MV walls serve as the shielding walls for the blast hatch and shall be minimum thickness of 200mm (with RC protective slab extended by at least 1/2 of storey height from the shielding wall) or 300mm (if the RC protective slab is extended by less than 1/2 of storey height). Refer to FIGURE 2.4.3(f).

Figures & Tables

FIGURE 2.4.3(f): USAGE OF TRELLIS (RC/STEEL HOLLOW SECTION) TO MAKE UP FOR SHORTFALL IN SETBACK DISTANCE (S/C SS)

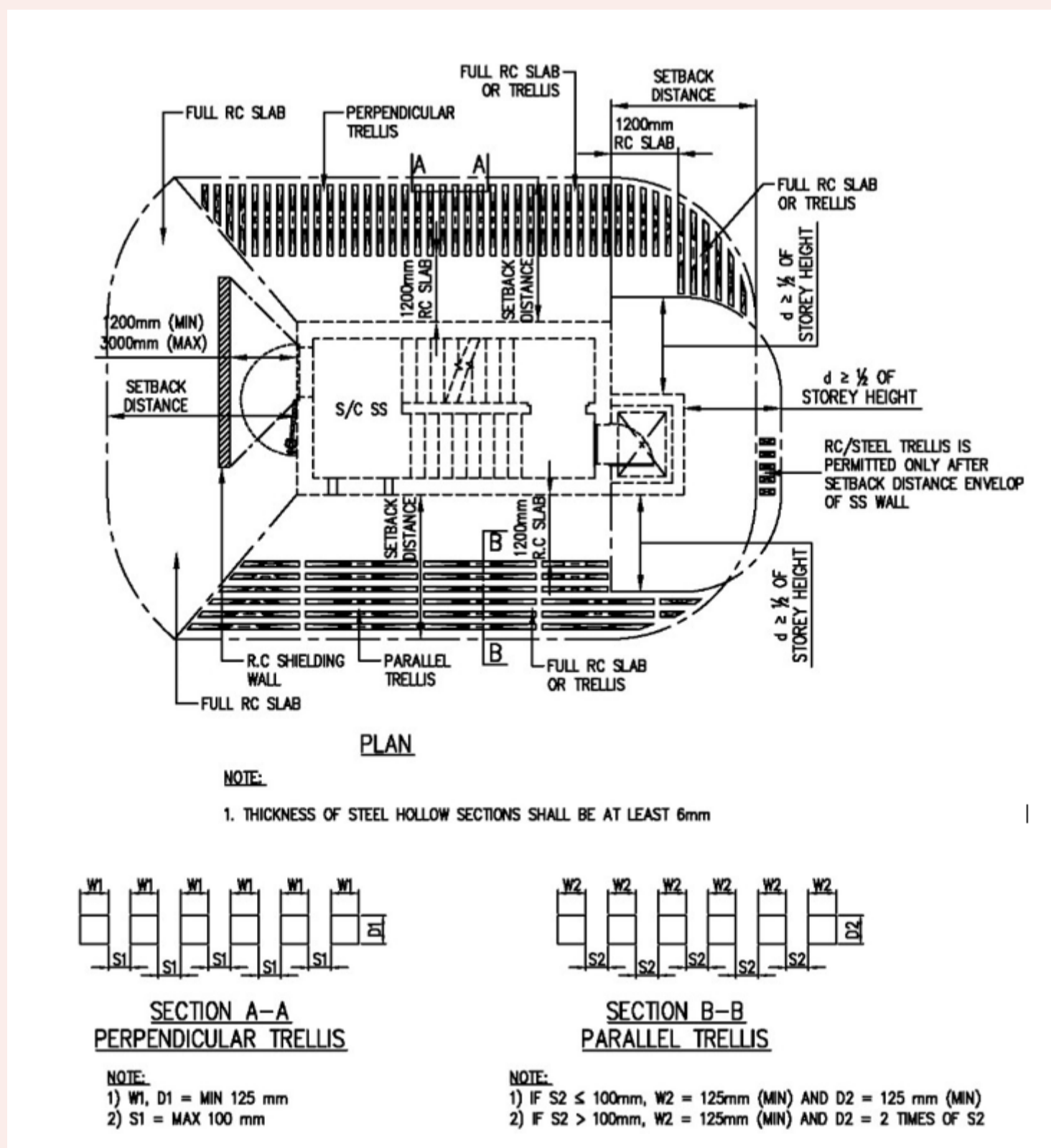

2.12.6 Blast Hatch at MV Chamber

a. Horizontal blast hatch shall be provided at the MV chamber at roof level as shown in FIGURE 2.12.6(a) to 2.12.6(d).

Figures & Tables

FIGURE 2.12.6(a) to 2.12.6(d)

FIGURE 2.12.6(a): PLAN OF S/C SS AT UPPER ROOF LEVEL

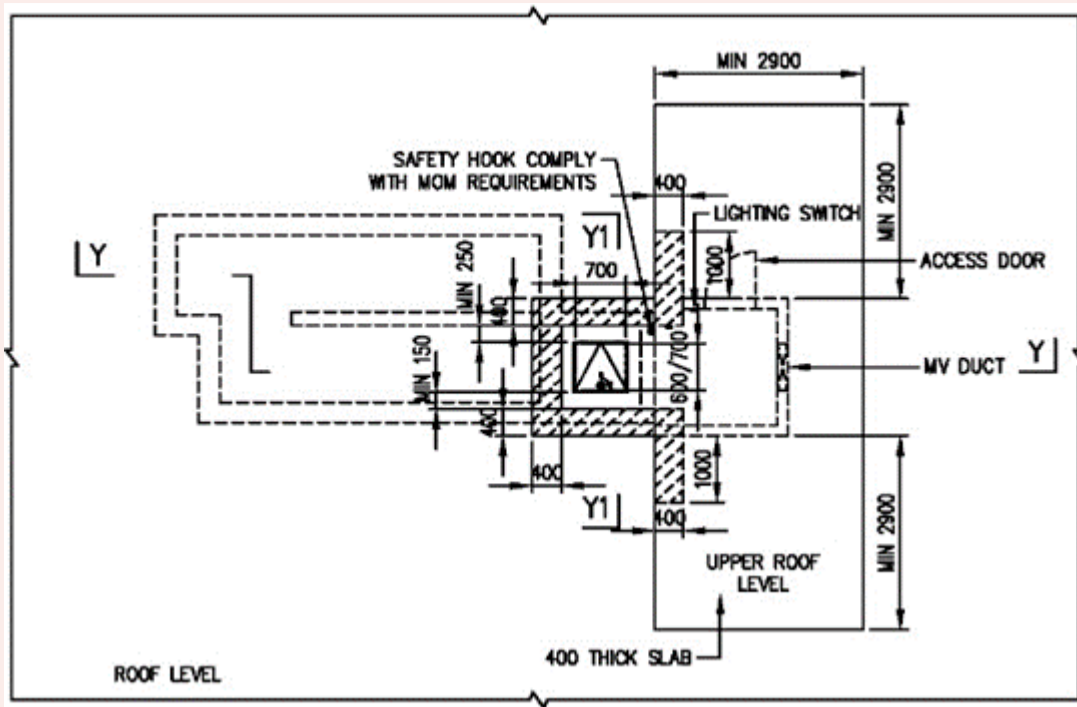

FIGURE 2.12.6(b): SECTION Y-Y OF S/C SS

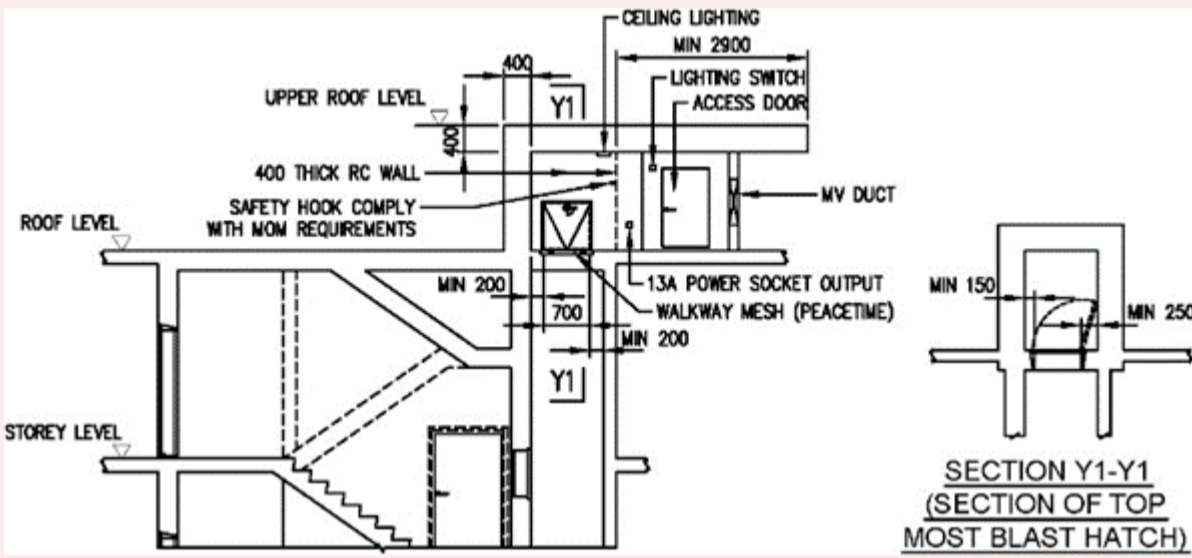

FIGURE 2.12.6(c): PLAN OF S/C SS AT UPPER ROOF LEVEL

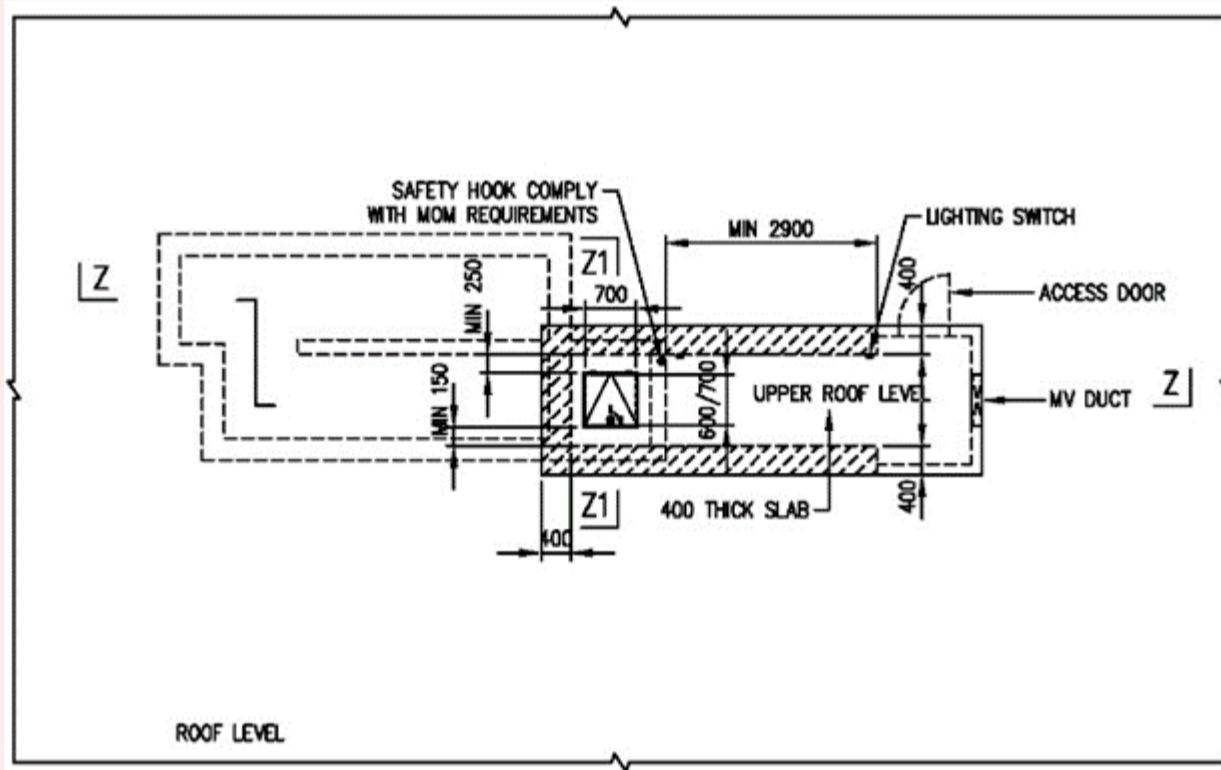
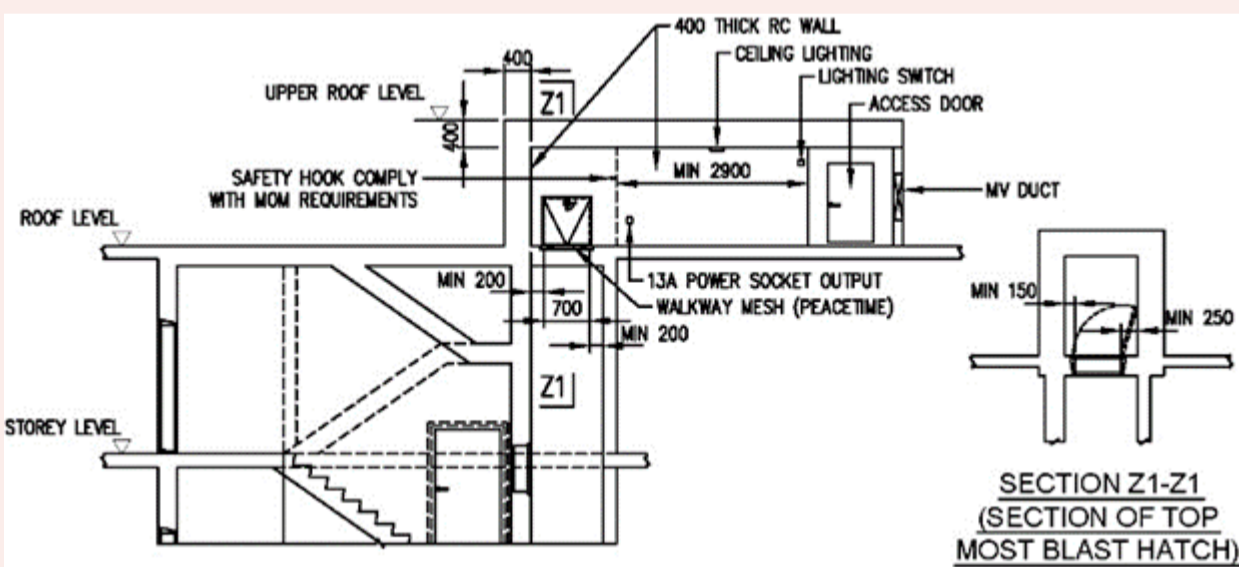

FIGURE 2.12.6(d): SECTION Z-Z OF S/C SS



b. Safety hook shall be provided in the protective wall next to the horizontal blast hatch opening at roof level as shown in FIGURE 2.12.6(a) to 2.12.6(d).

c. An unobstructed passageway shall be provided to the roof level for the operation and maintenance of the blast hatch in the MV chamber.

Figures & Tables

FIGURE 2.12.6(a) to 2.12.6(d)

FIGURE 2.12.6(a): PLAN OF S/C SS AT UPPER ROOF LEVEL

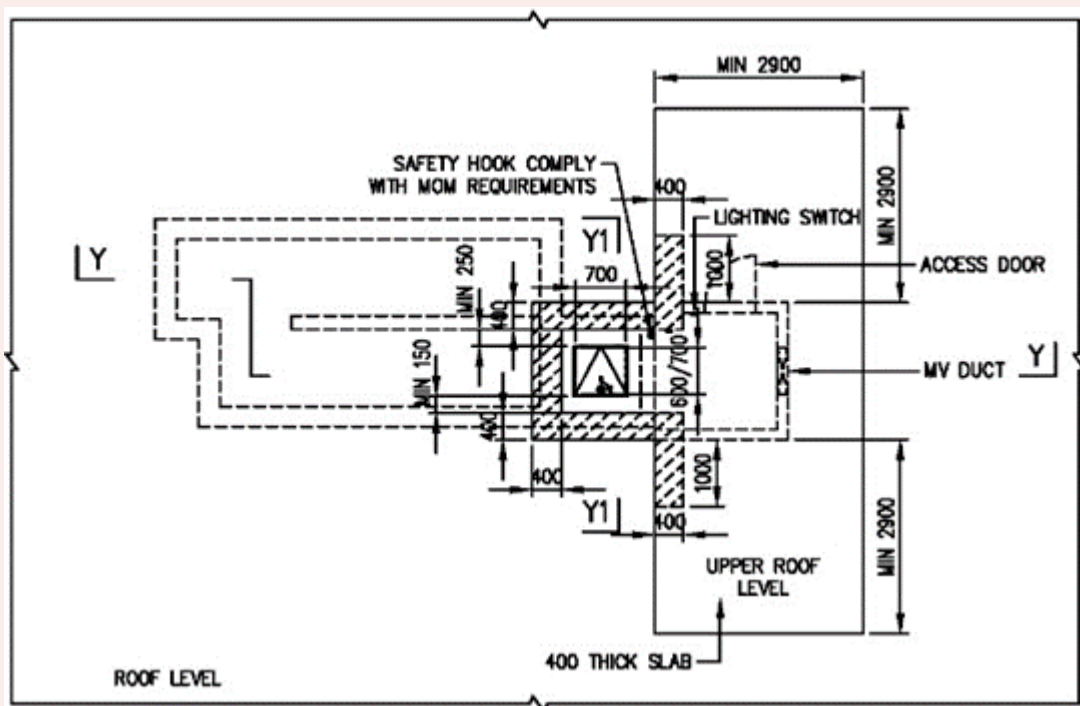

FIGURE 2.12.6(b): SECTION Y-Y OF S/C SS

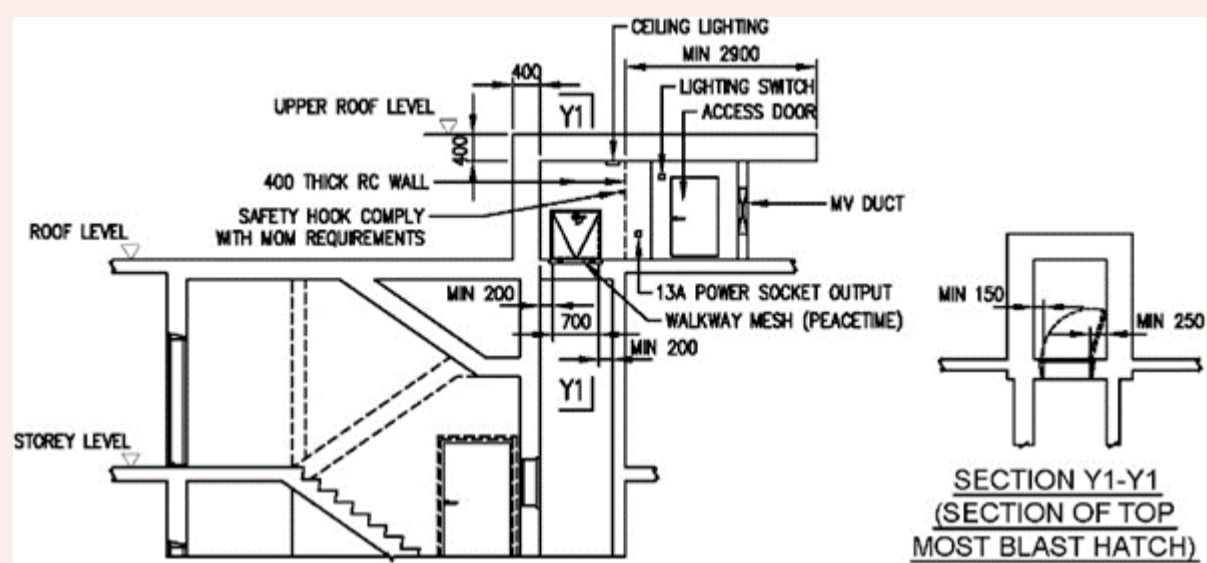

FIGURE 2.12.6(c): PLAN OF S/C SS AT UPPER ROOF LEVEL

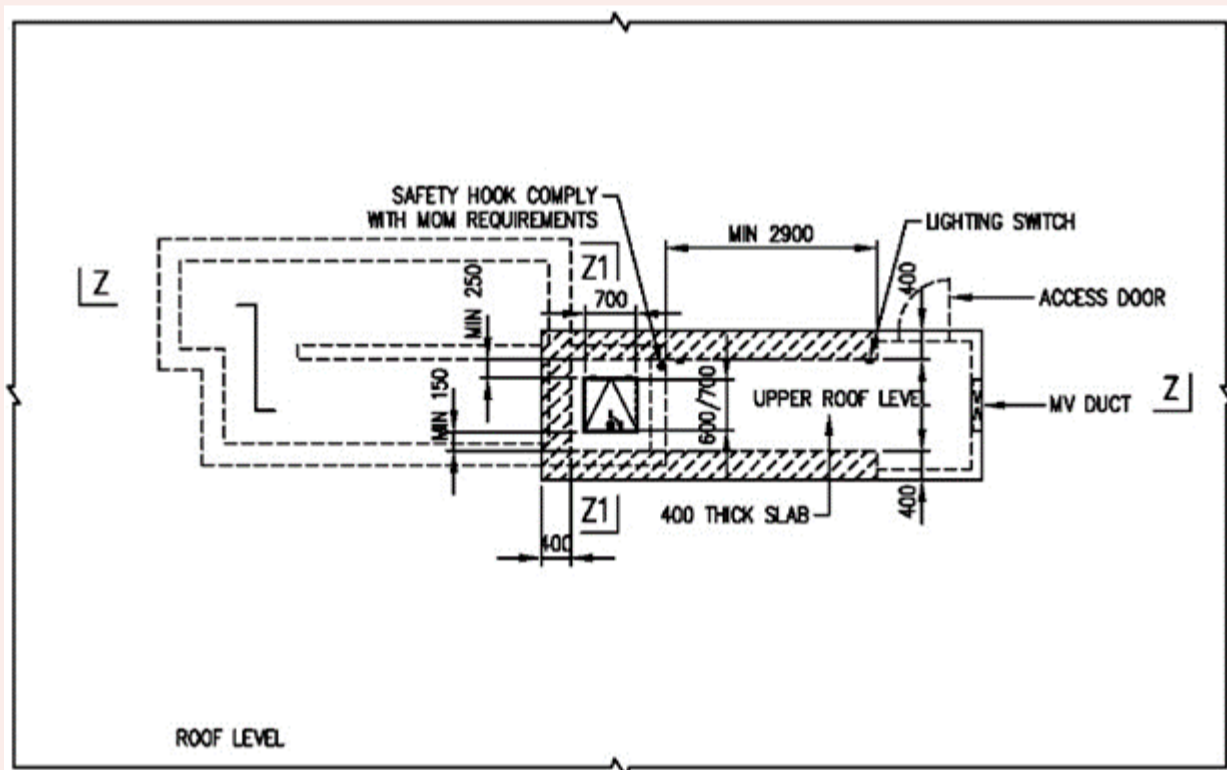
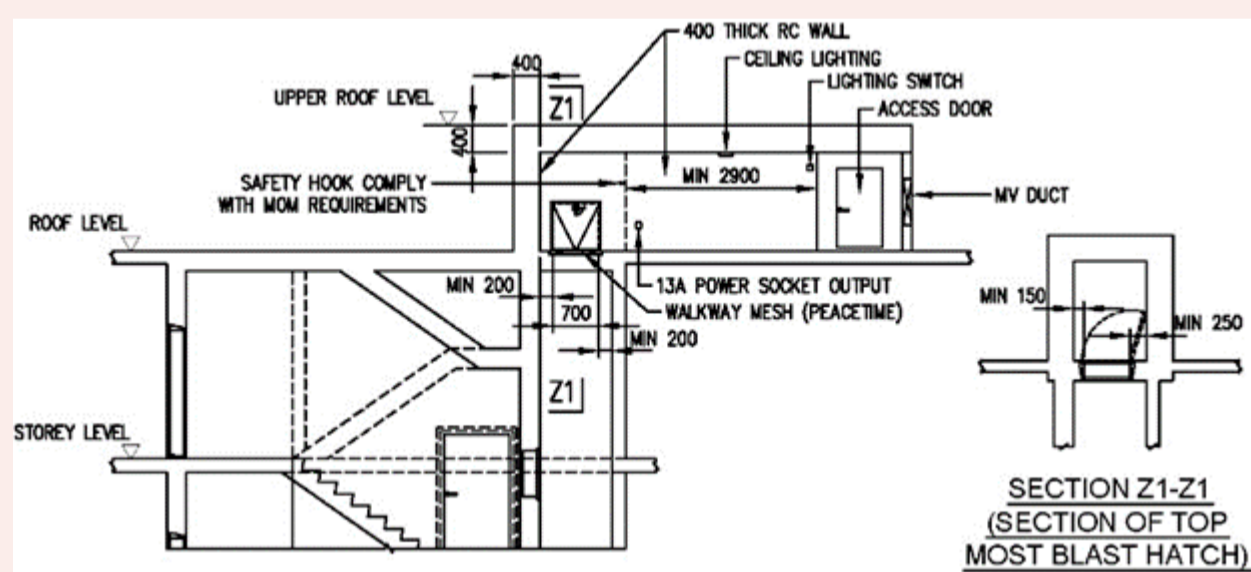

FIGURE 2.12.6(d): SECTION Z-Z OF S/C SS



d. Ceiling light, switch, single power socket outlet and safety steel mess shall be provided in the MV chamber as shown in FIGURE 2.12.6(a) to 2.12.6(d).

Figures & Tables

FIGURE 2.12.6(a) to 2.12.6(d)

FIGURE 2.12.6(a): PLAN OF S/C SS AT UPPER ROOF LEVEL

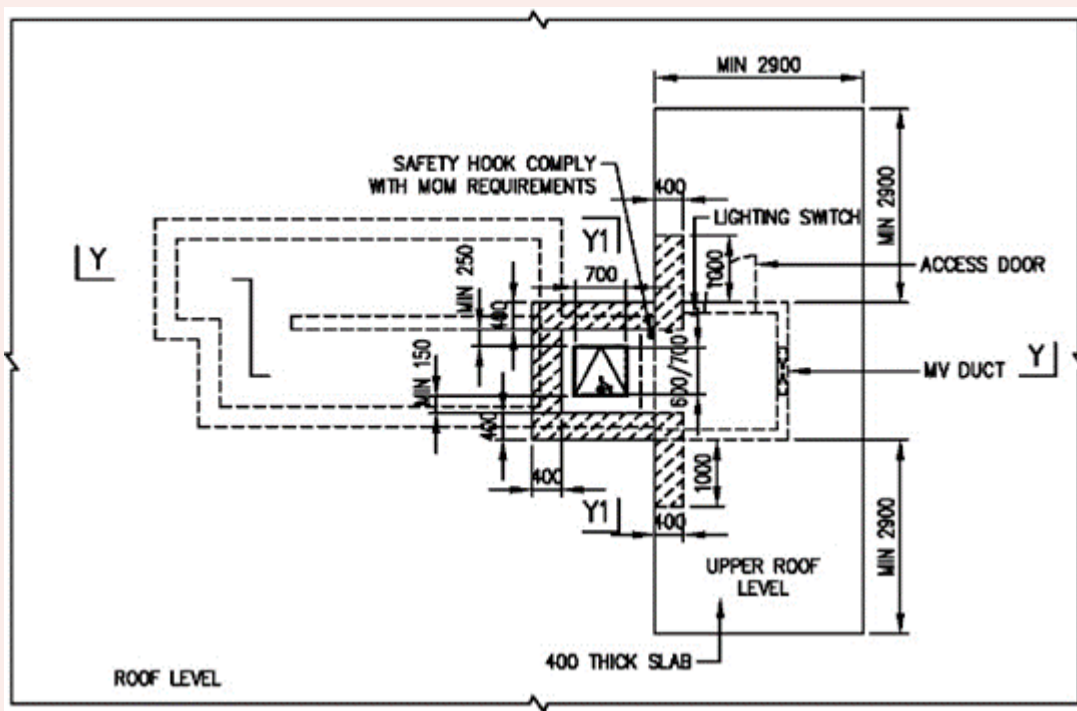

FIGURE 2.12.6(b): SECTION Y-Y OF S/C SS

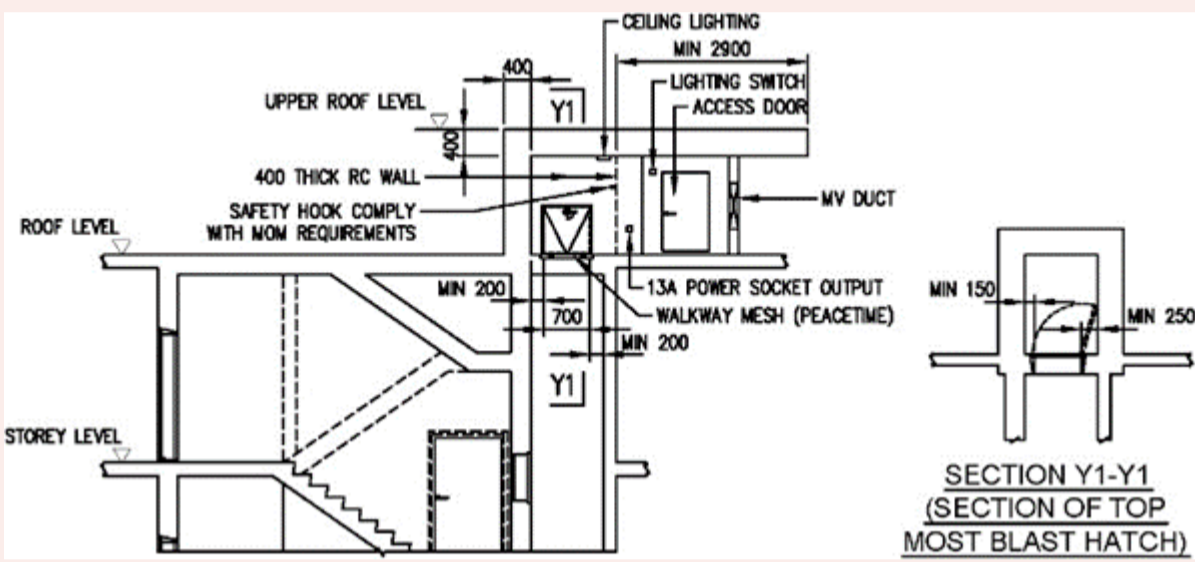

FIGURE 2.12.6(c): PLAN OF S/C SS AT UPPER ROOF LEVEL

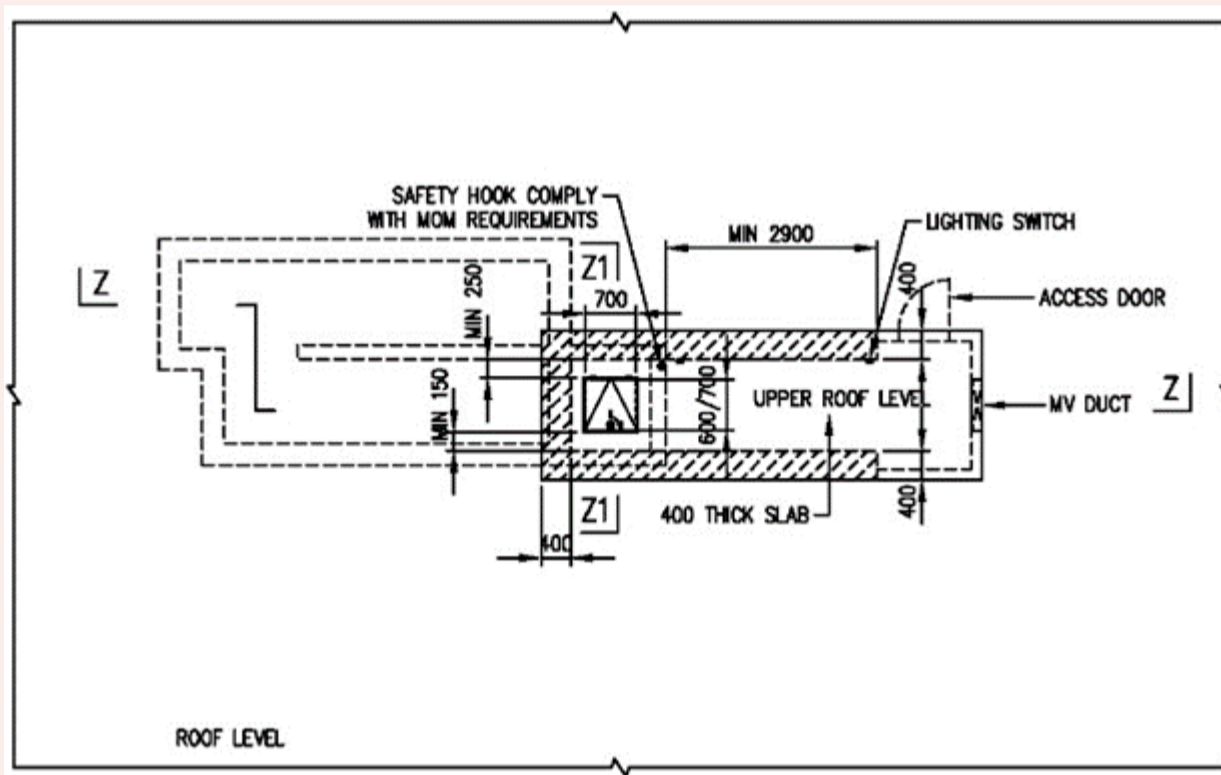
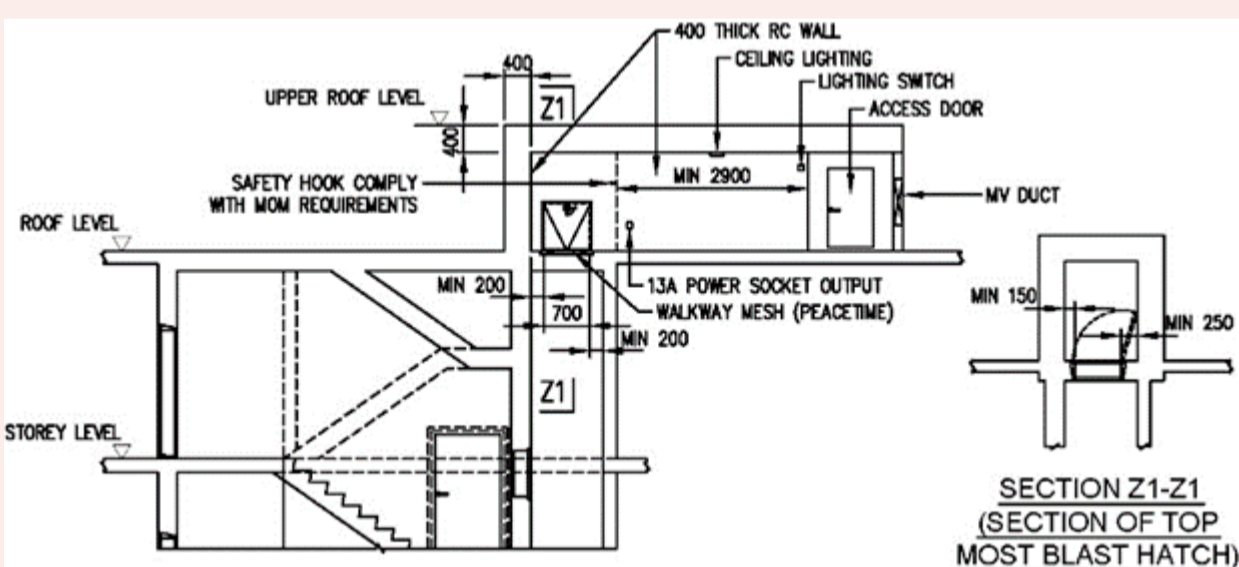

FIGURE 2.12.6(d): SECTION Z-Z OF S/C SS



2.12.7 Dimensions and Other Requirements of Blast Hatch

- a. The minimum size of the vertical panel or MV grille for access to open/close the vertical blast hatch between the MV riser and staircase SS shall be 600/700mm by 700mm. The internal SS door shall be positioned such that it swings away from the vertical blast hatch opening. Refer to FIGURE 2.12.1(f) and 2.12.2(j).

Figures & Tables

FIGURE 2.12.1(f): TYPICAL PLAN OF S/C SS COMPARTMENT

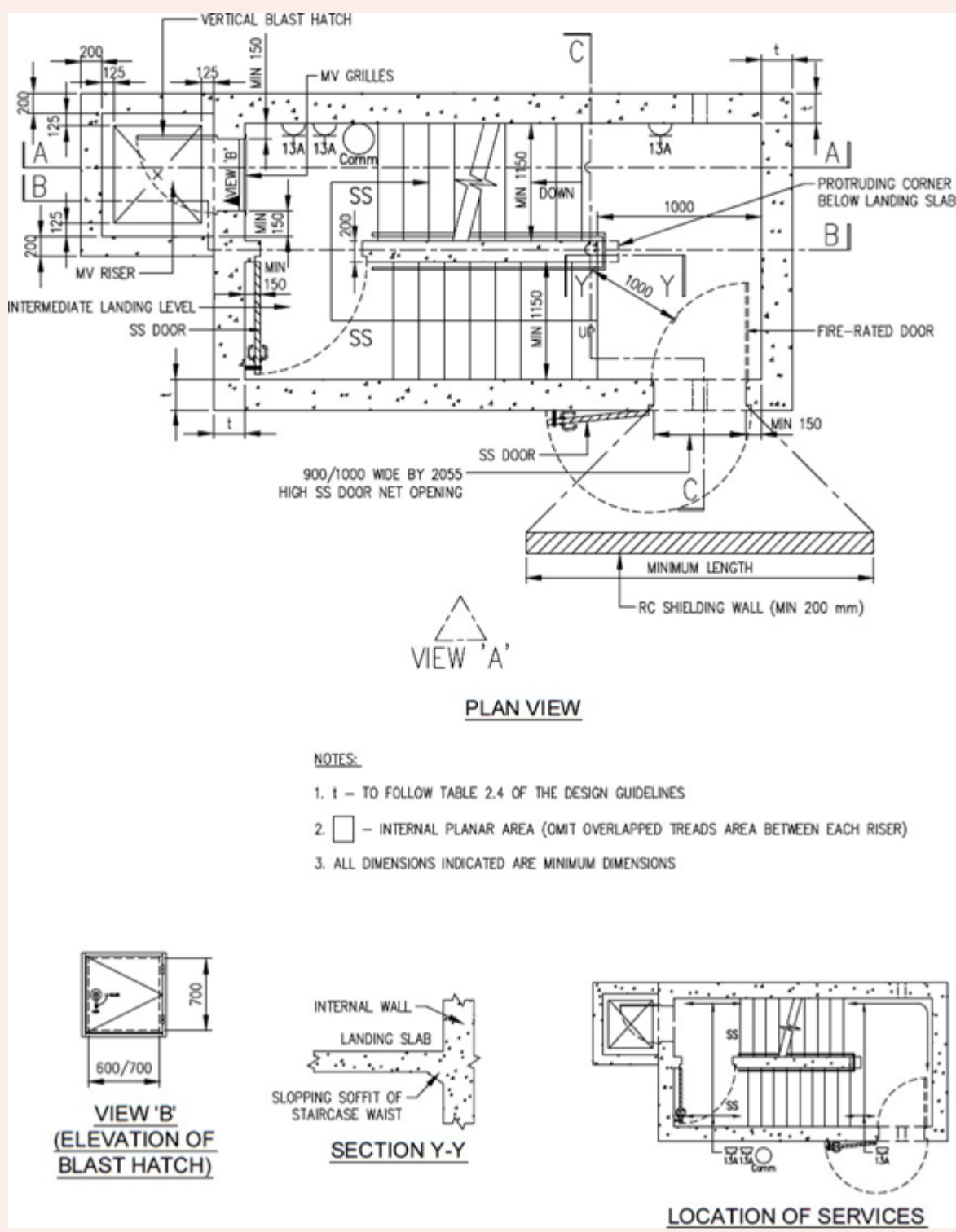
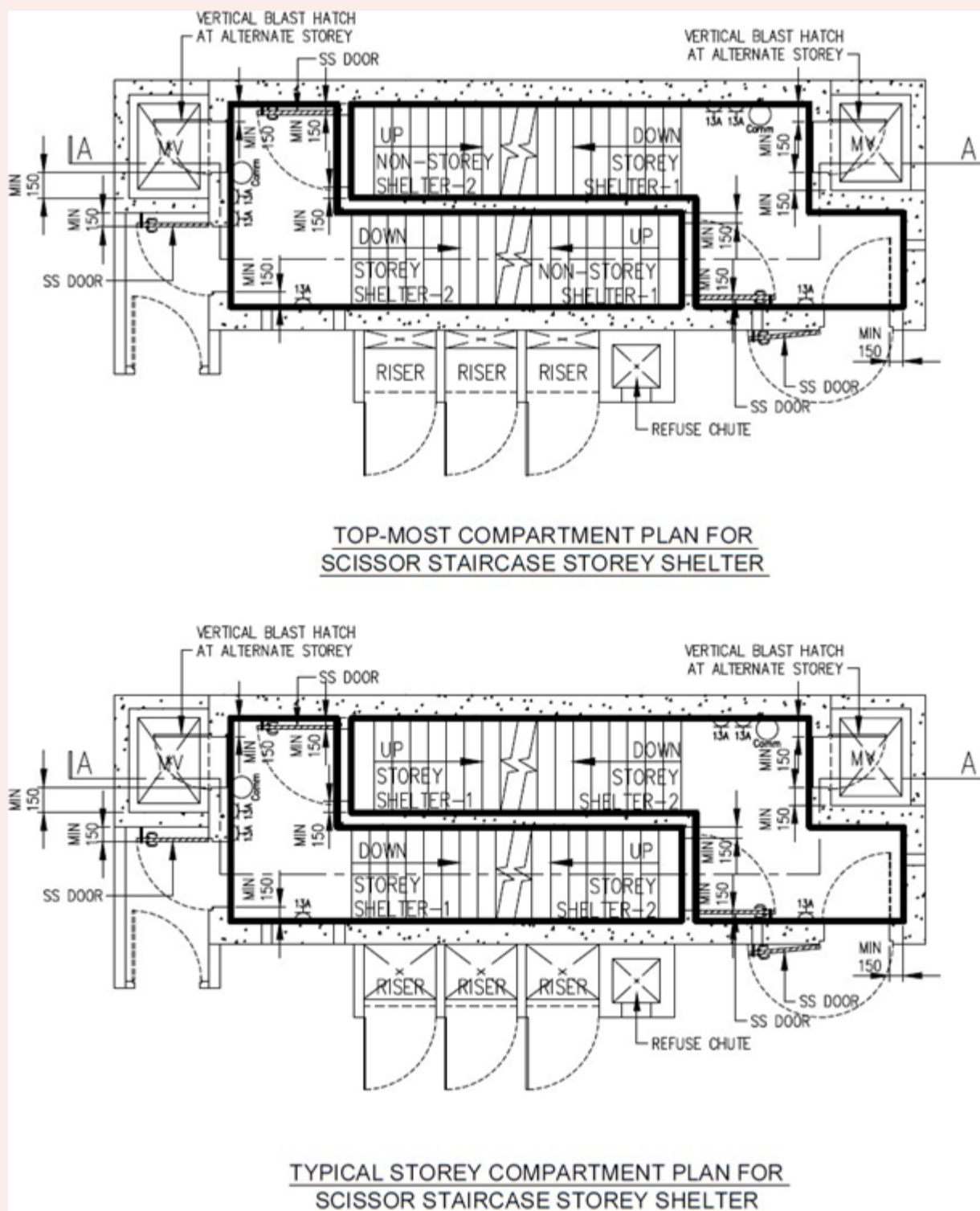

FIGURE 2.12.2(j): SCISSOR S/C SS COMPARTMENT PLAN



b. There shall be reinforced concrete ledge or steel ledge provided around the MV duct for inspection and maintenance of the vertical blast hatch. Refer to FIGURE 2.12.1(f), 2.12.2(c) and 2.12.2(k).

Figures & Tables

FIGURE 2.12.1(f): TYPICAL PLAN OF S/C SS COMPARTMENT

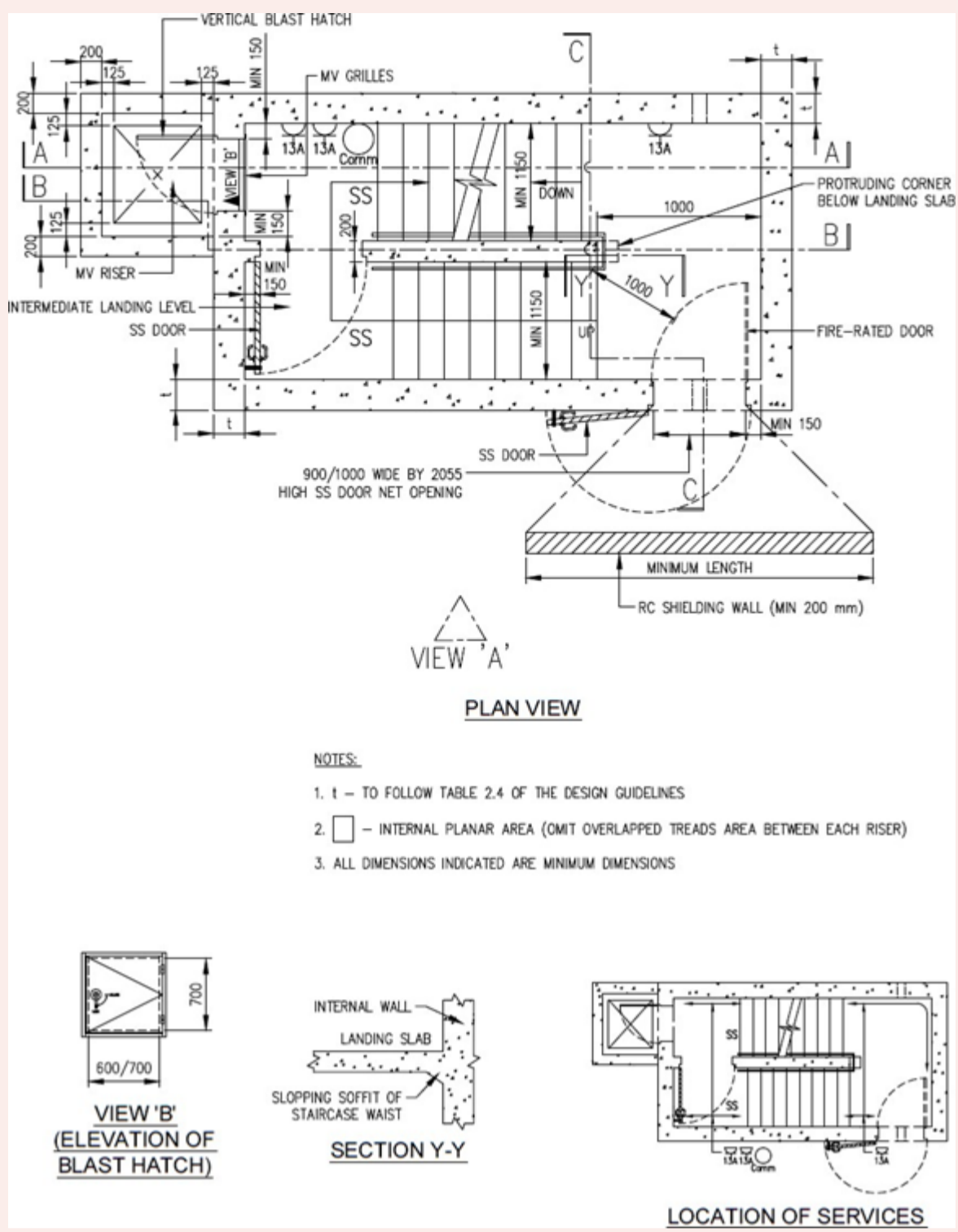

FIGURE 2.12.2(c): SS WITH NS ABOVE TOP-MOST SS COMPARTMENT, INTERMEDIATE SS COMPARTMENT AND SS WITH NS BELOW BOTTOM-MOST SS COMPARTMENT

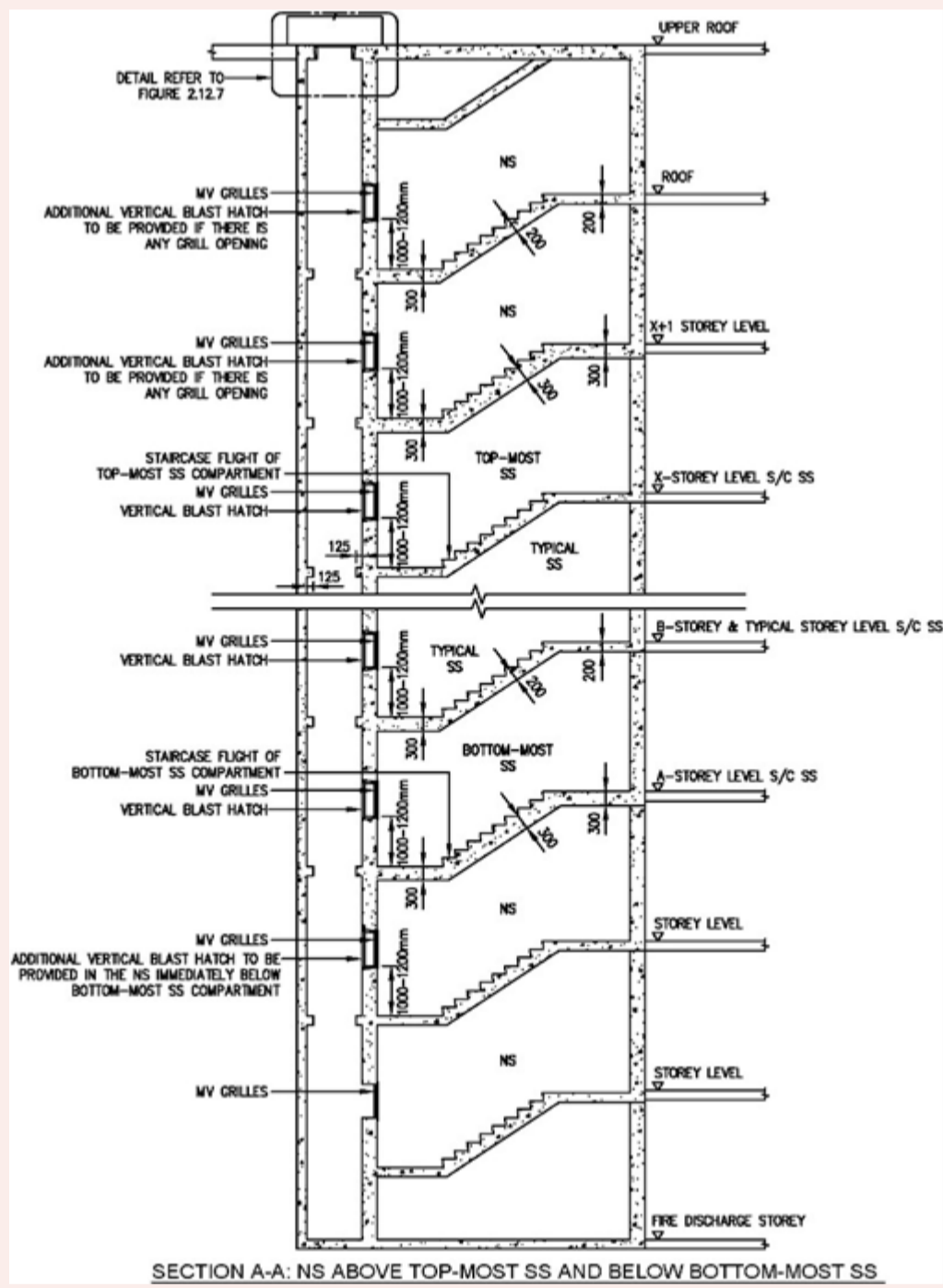
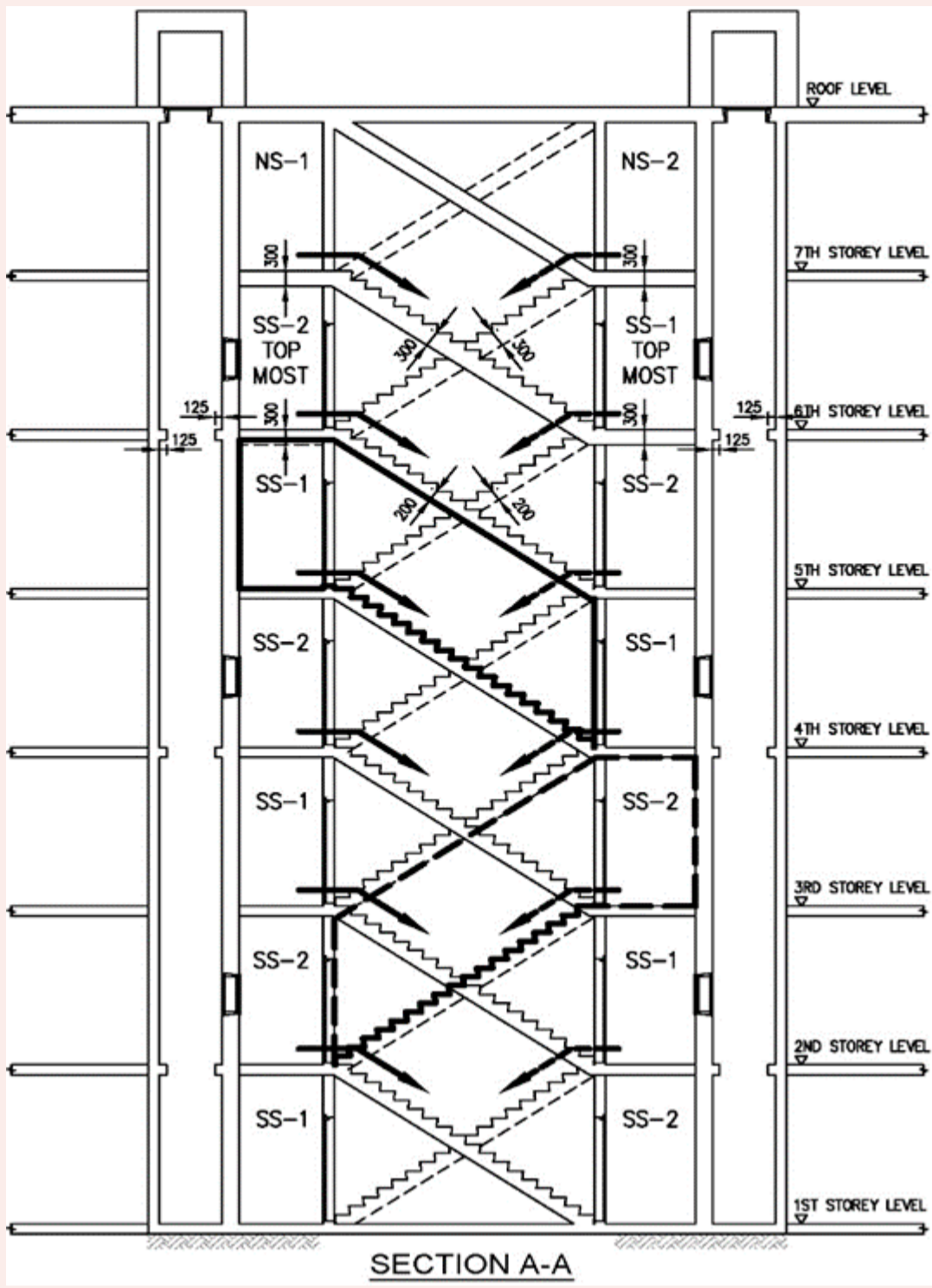

FIGURE 2.12.2(k): SECTION OF SCISSOR S/C SS COMPARTMENT



c. The details of the nib dimensions for horizontal blast hatch opening at the MV chamber are as shown in FIGURE 2.12.6(a) to 2.12.6(d).

Figures & Tables

FIGURE 2.12.6(a) to 2.12.6(d)

FIGURE 2.12.6(a): PLAN OF S/C SS AT UPPER ROOF LEVEL

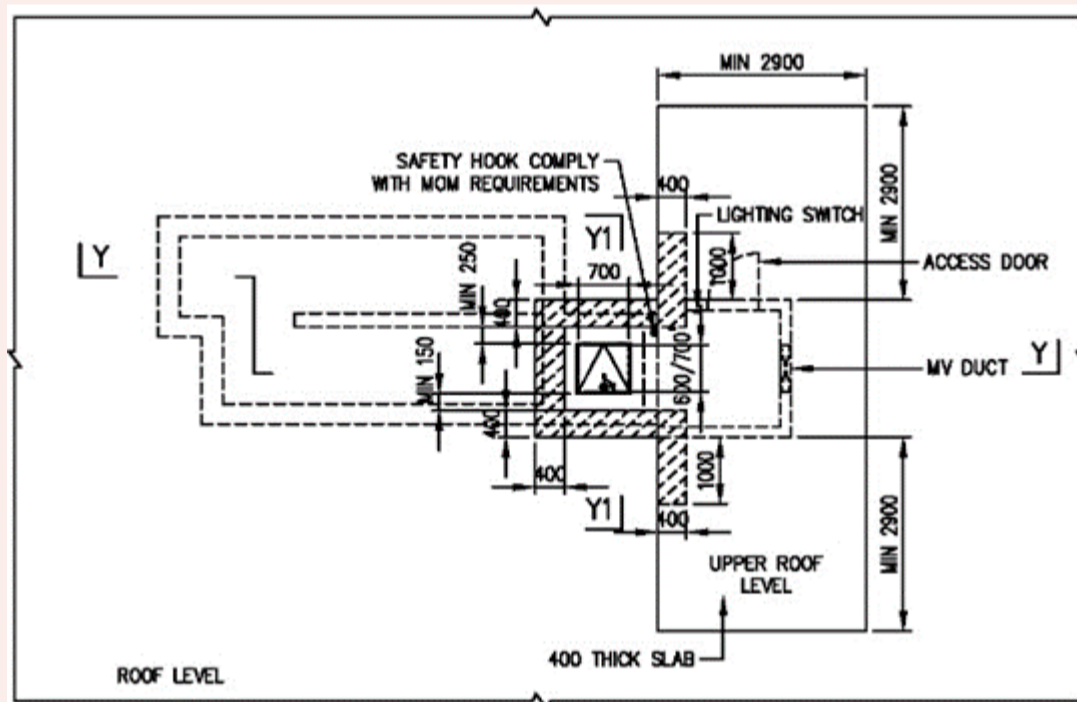

FIGURE 2.12.6(b): SECTION Y-Y OF S/C SS

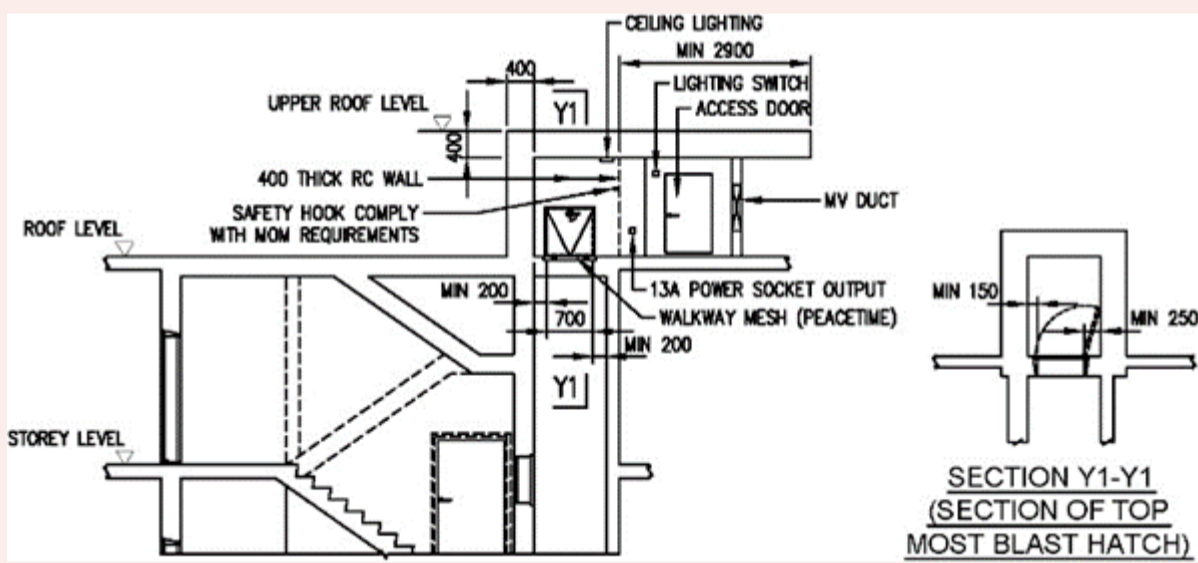

FIGURE 2.12.6(c): PLAN OF S/C SS AT UPPER ROOF LEVEL

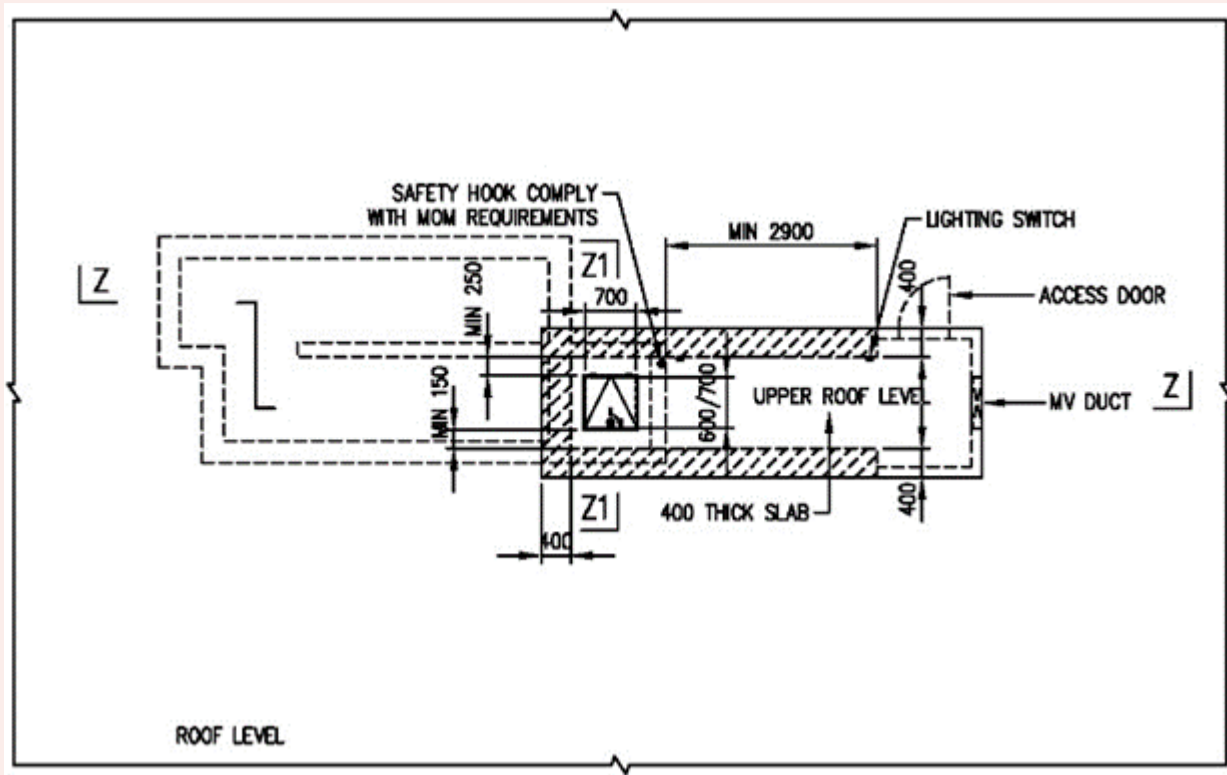
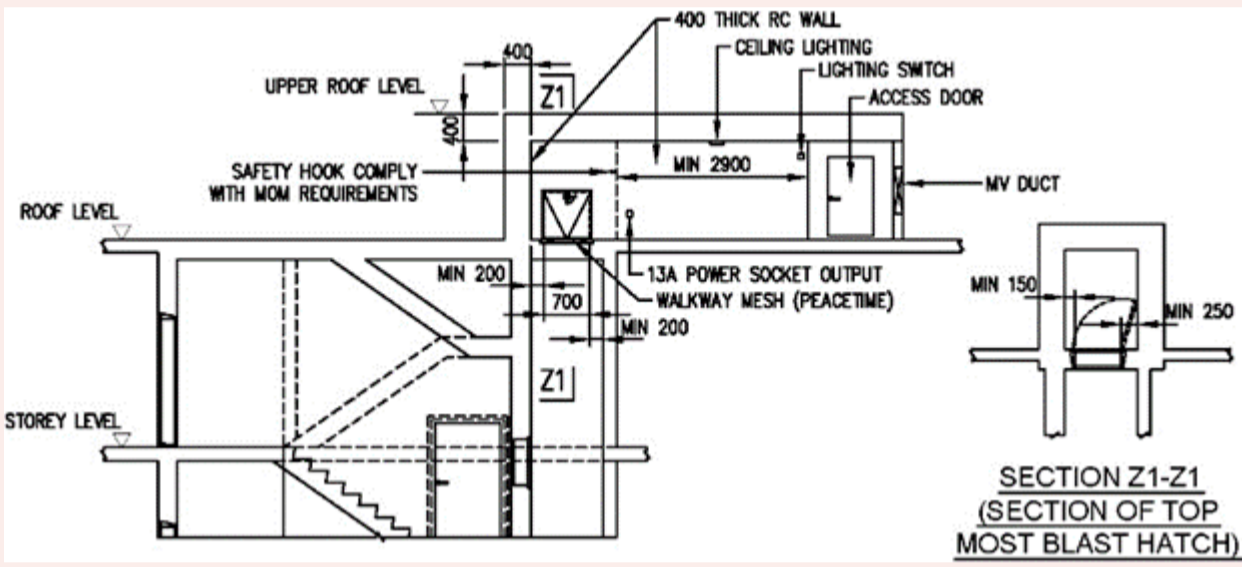

FIGURE 2.12.6(d): SECTION Z-Z OF S/C SS



d. The net clear opening of the vertical and horizontal blast hatches shall be 600/700mm x 700mm as shown in FIGURE 2.12.7(a) and 2.12.7(b).

Figures & Tables

FIGURE 2.12.7(a): MINIMUM DIMENSION OF VERTICAL BLAST HATCH

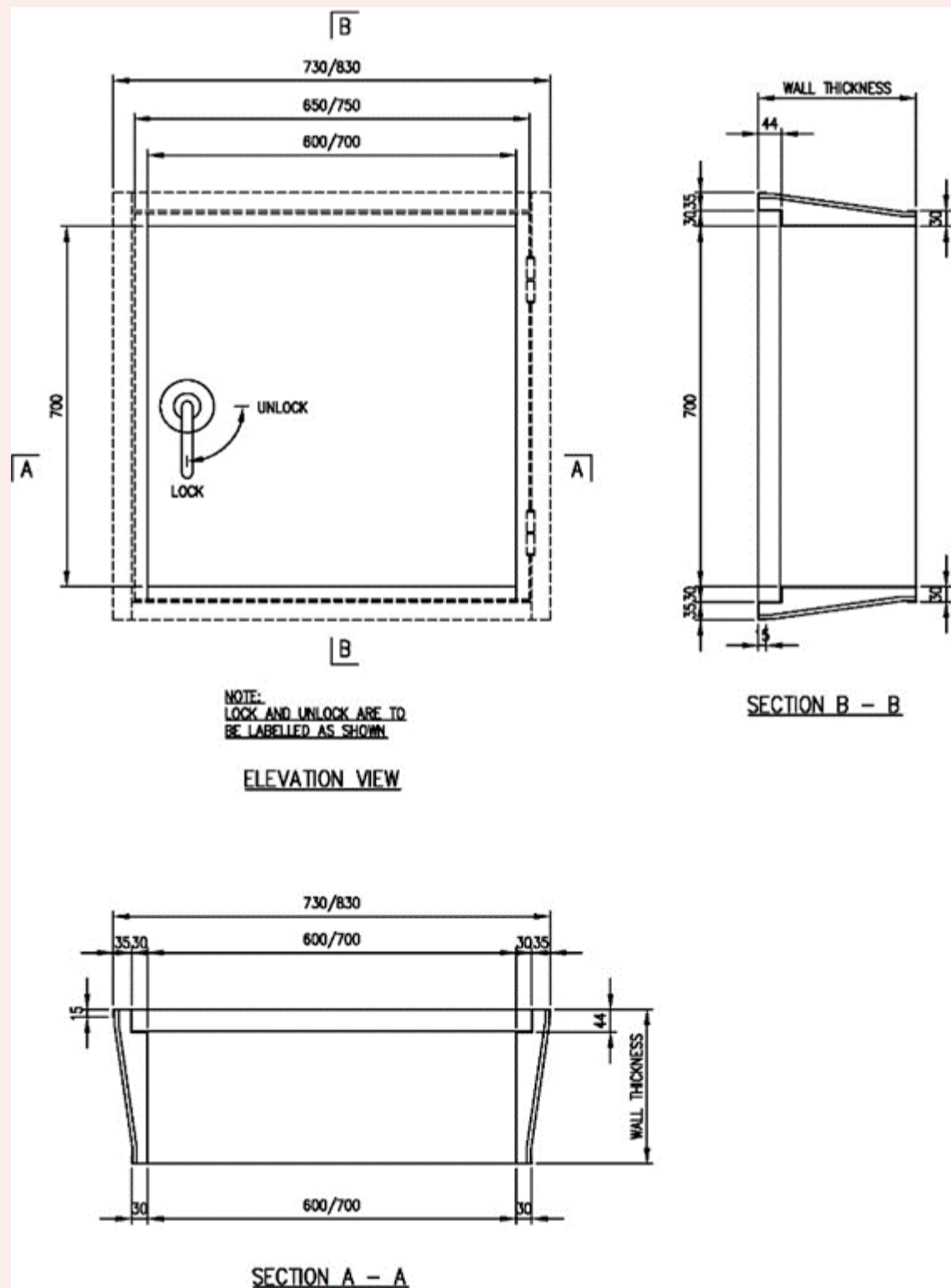
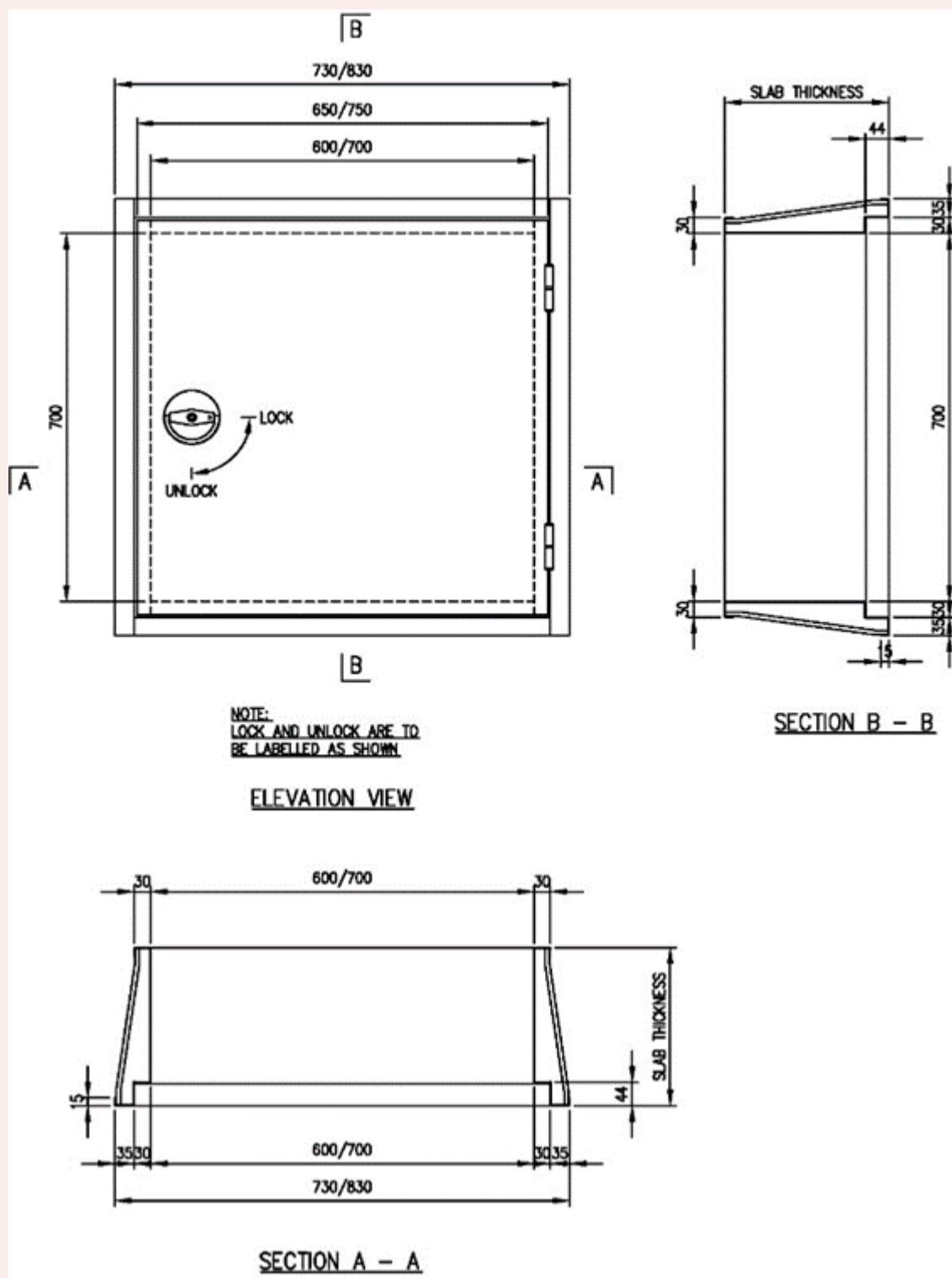

FIGURE 2.12.7(b): MINIMUM DIMENSION OF HORIZONTAL BLAST HATCH



e. Unlocking” or “Locking” label or sticker to indicate the unlocking or locking position at the locking device shall be provided for all blast hatches. Refer to FIGURE 2.12.7(a) and 2.12.7(b).

Figures & Tables

FIGURE 2.12.7(a): MINIMUM DIMENSION OF VERTICAL BLAST HATCH

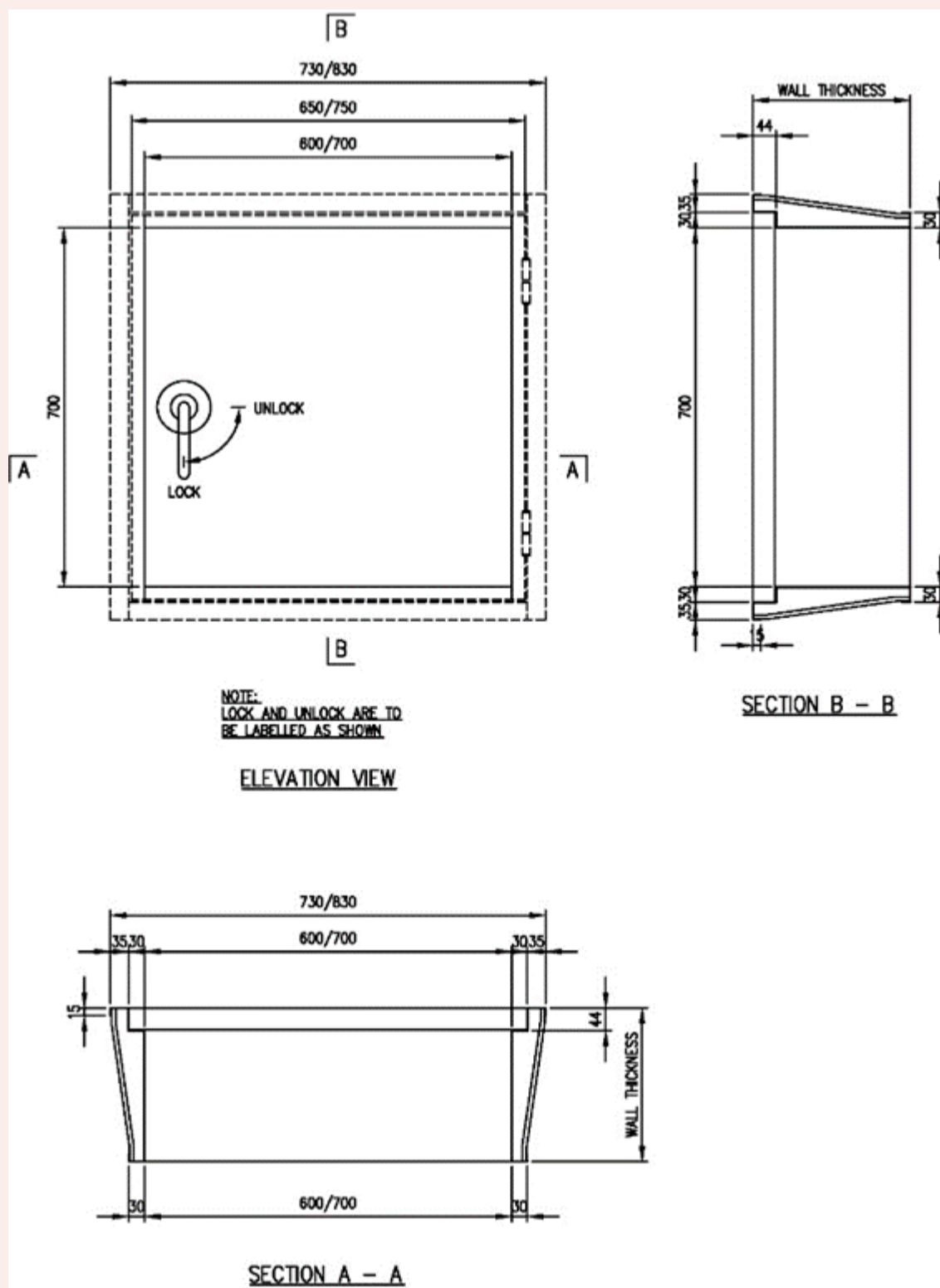
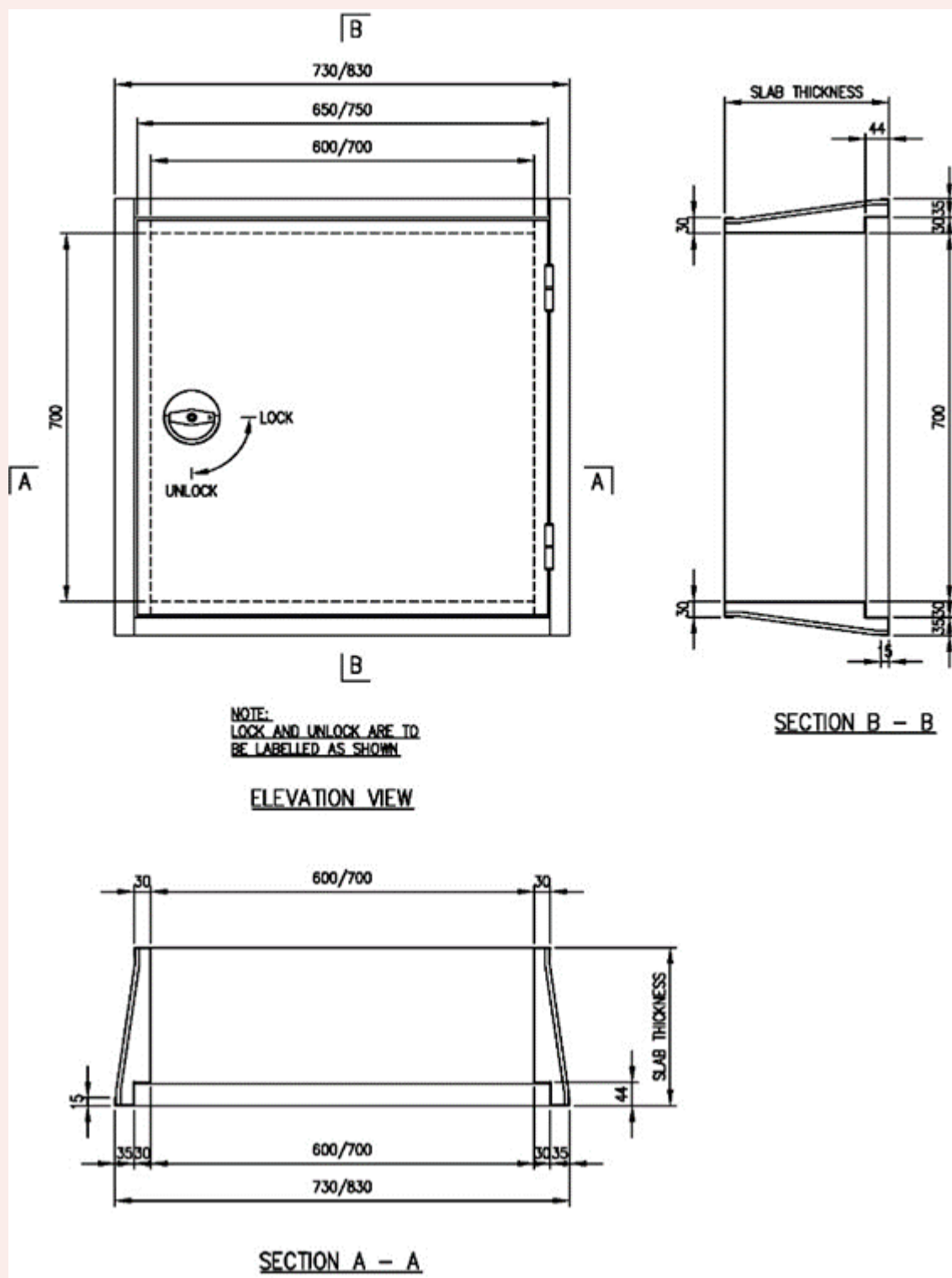

FIGURE 2.12.7(b): MINIMUM DIMENSION OF HORIZONTAL BLAST HATCH



2.12.8 Provision of cut-off Sprinkler outside S/C SS and Scissor S/C SS

Where cut-off sprinkler is required to be provided in the fire-protected space for the compliance to fire safety, the cut-off sprinkler compartment shall be provided outside the S/C SS. Refer to FIGURE 2.12.8.

Figures & Tables

FIGURE 2.12.8: PROVISION OF CUT-OFF SPRINKLER IN S/C SS

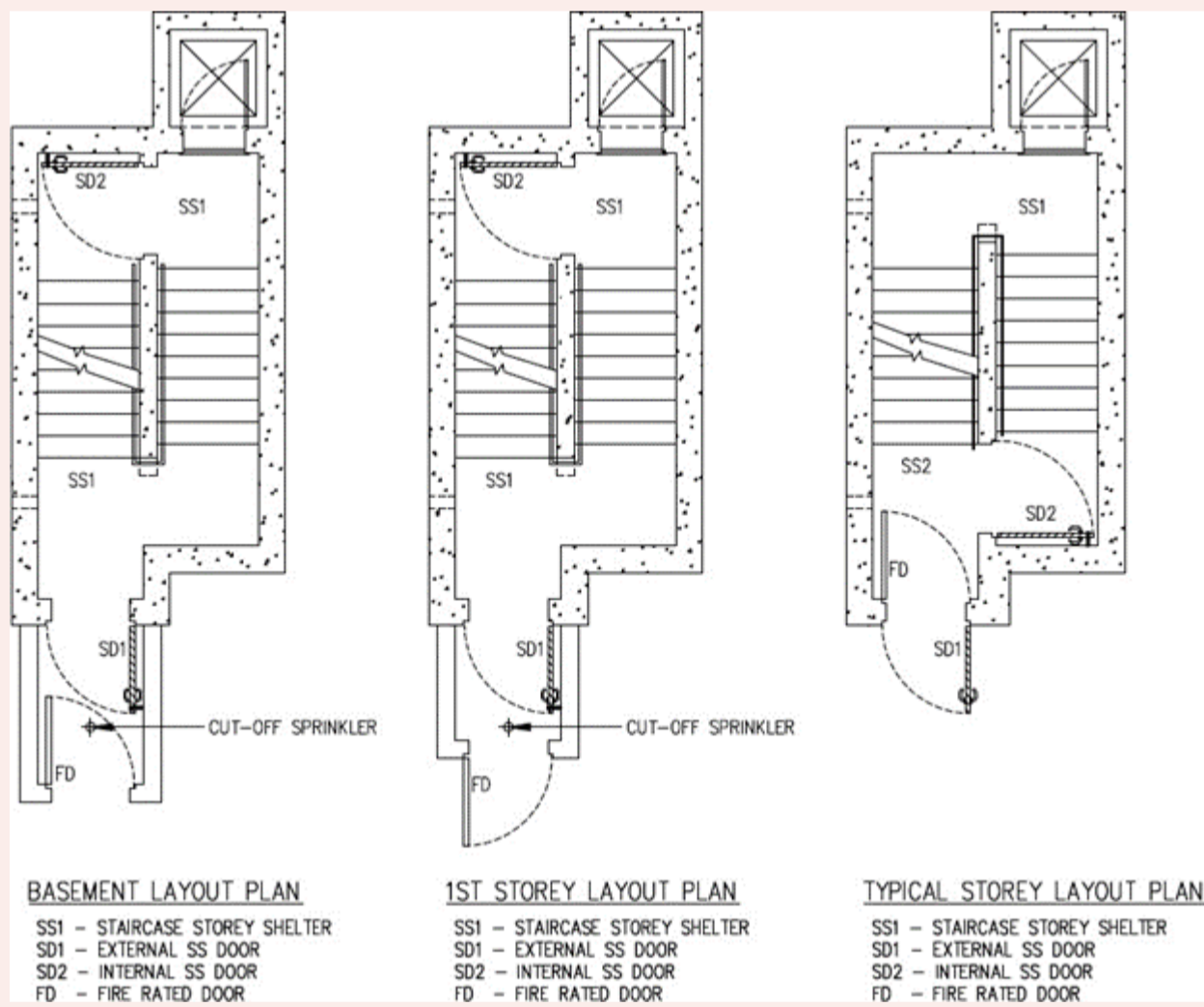

Clause No.	Amendment Date	Effective Date	Clause Status	Clause Before Amendment	Circular Date
------------	----------------	----------------	---------------	-------------------------	---------------

CLAUSE 3.1 GENERAL

The structural design of the SS tower shall take into account both the vertical and lateral loads, where applicable. The SS tower shall be designed for maximum degrees of redundancy in the structural system against weapon effects.

CLAUSE 3.2 MATERIALS

3.2.1 Concrete

The minimum grade of concrete for all SS/NS structures shall be C32/40. Concrete used in SS/NS structures (including hollow core and joints), as well as concrete used for structures within shelter setback distance, should be of normal concrete density (2400kg/m³) and consists of 20mm nominal maximum size coarse aggregate. The use of pre-stressed concrete for SS wall/slab and NS wall/slab in the SS, S/C SS or scissor S/C SS tower is not permitted.

3.2.2 Steel Reinforcement

The steel reinforcement in SS/NS wall and slab shall be welded steel fabric mesh for steel bar diameter of up to 16mm and hot rolled steel bars. The minimum yield stress of main reinforcement bars and shear links in the structural elements forming the SS, S/C SS or scissor S/C SS or NS shall be minimum 500 N/mm².

CLAUSE 3.3 ANALYSIS

3.3.1 General

The vertical continuity of SS and NS walls, where applicable, to the foundation shall comply with [Clause 2.4.2](#). In the case of S/C SS or scissor S/C SS tower, the SS and NS wall shall be continuous to foundation, except where there are fire discharge openings at fire discharge levels. The fire discharge openings shall be located such that all corners of the S/C SS walls are continuous to foundation.

3.3.2 Beam Supported on SS wall

The end of the external beam that is supported on SS wall(s) shall be designed and detailed as simply support.

3.3.3 Shielded NS Walls (2 opposite NS wall [not applicable for S/C SS tower] or 4 NS walls)

No additional design checks on SS tower is required if its supporting wall(s) are shielded. These structural walls are deemed shielded if reinforced concrete slab or other equivalent structural forms provided above them is extended beyond their edges by as minimum length of $0.5H$, where H is the aggregate wall height of NS (See [FIGURE 3.3.3](#) and [3.3.4\(c\)](#)).

Figures & Tables

FIGURE 3.3.3: SHIELDED NS WALLS OF SS TOWER (2 OPPOSITE NS WALLS NOT APPLICABLE FOR S/C SS TOWER)

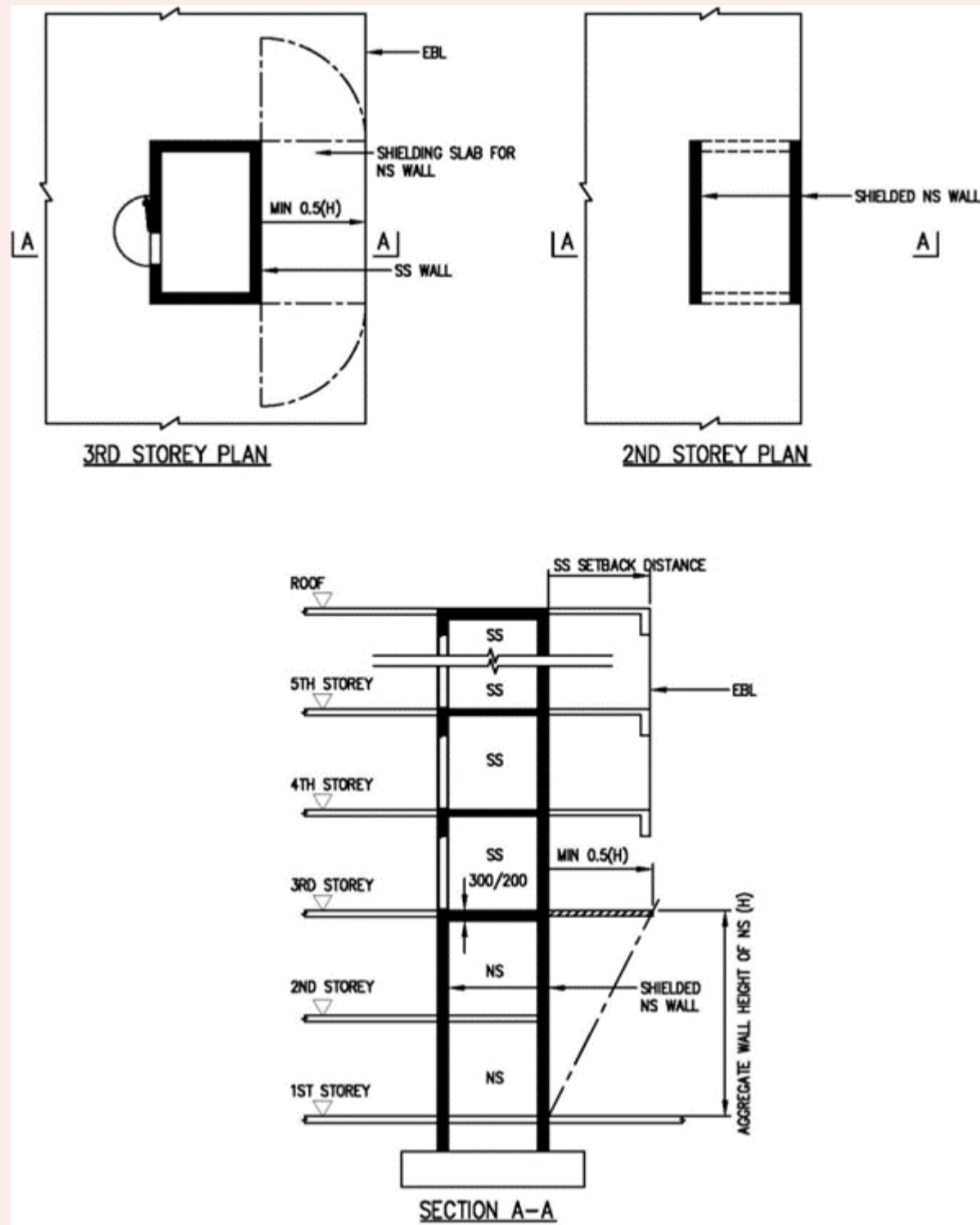
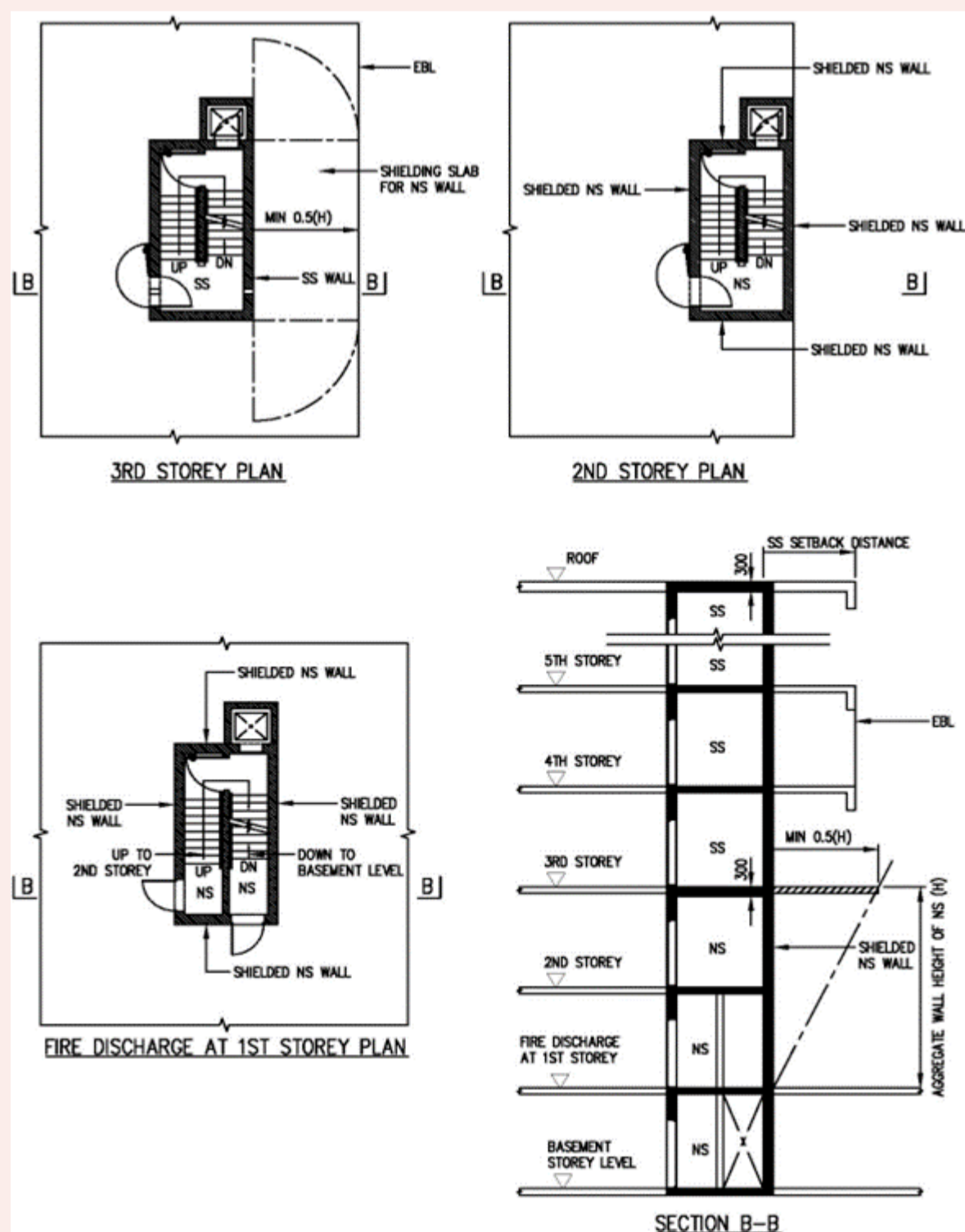

FIGURE 3.3.4(c): SHIELDED NS WALL(S) OF S/C SS TOWER



3.3.4 Unshielded NS Walls (2 opposite NS walls [not applicable for S/C SS tower] or 4 NS walls)

The following requirements are to be complied with if the design adopts:

a. Unshielded NS Walls

The minimum thickness of each NS wall shall be 300mm. The SS, S/C SS or scissor S/C SS tower shall be designed against the most severe effects as the result of the removal of a portion of the NS wall equivalent to an opening of 1500mm diameter on the NS wall at its most critical location (Refer to FIGURE 3.3.4(a), 3.3.4(b) and 3.3.4(d)).

b. The following are the criteria to be used when performing design checks for [Clause 3.3.4\(a\)](#):

Figures & Tables

FIGURE 3.3.4(a): UNSHIELDED NS WALL(S) OF SS TOWER

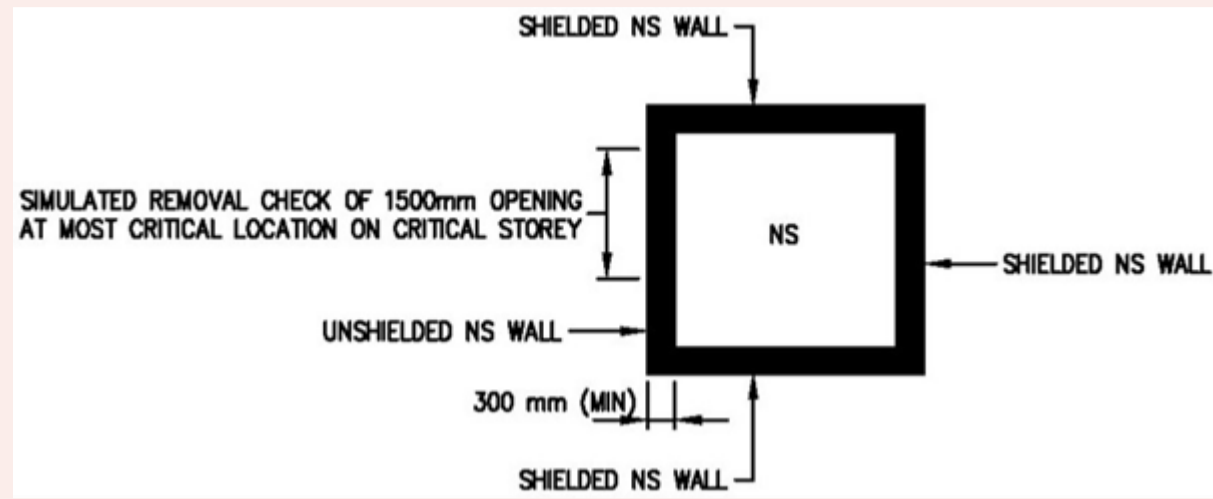

FIGURE 3.3.4(b): UNSHIELDED NS WALL(S) OF SS TOWER (2 OPPOSITE NS WALLS NOT APPLICABLE FOR S/C SS TOWER)

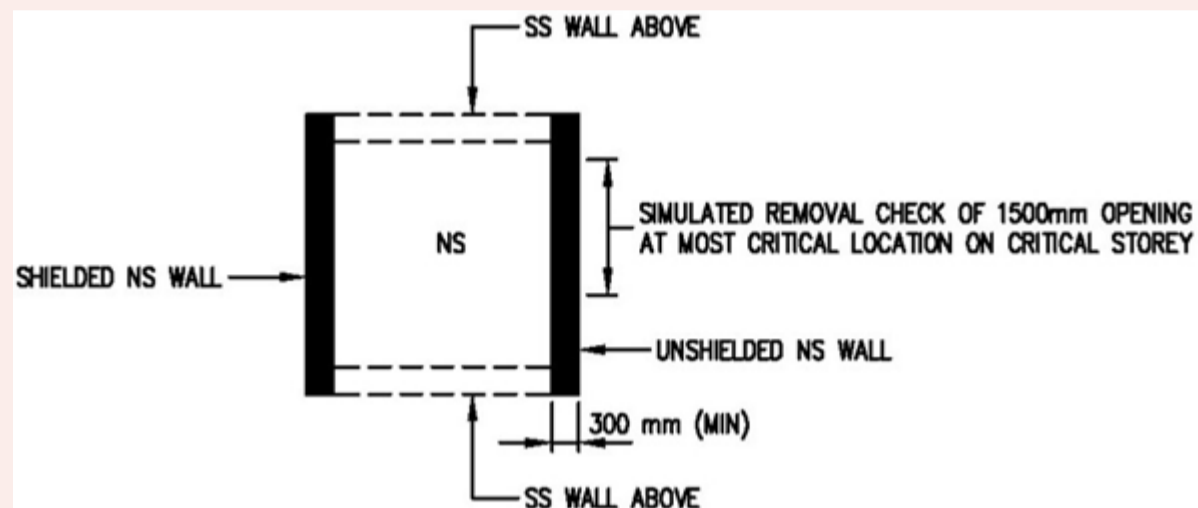
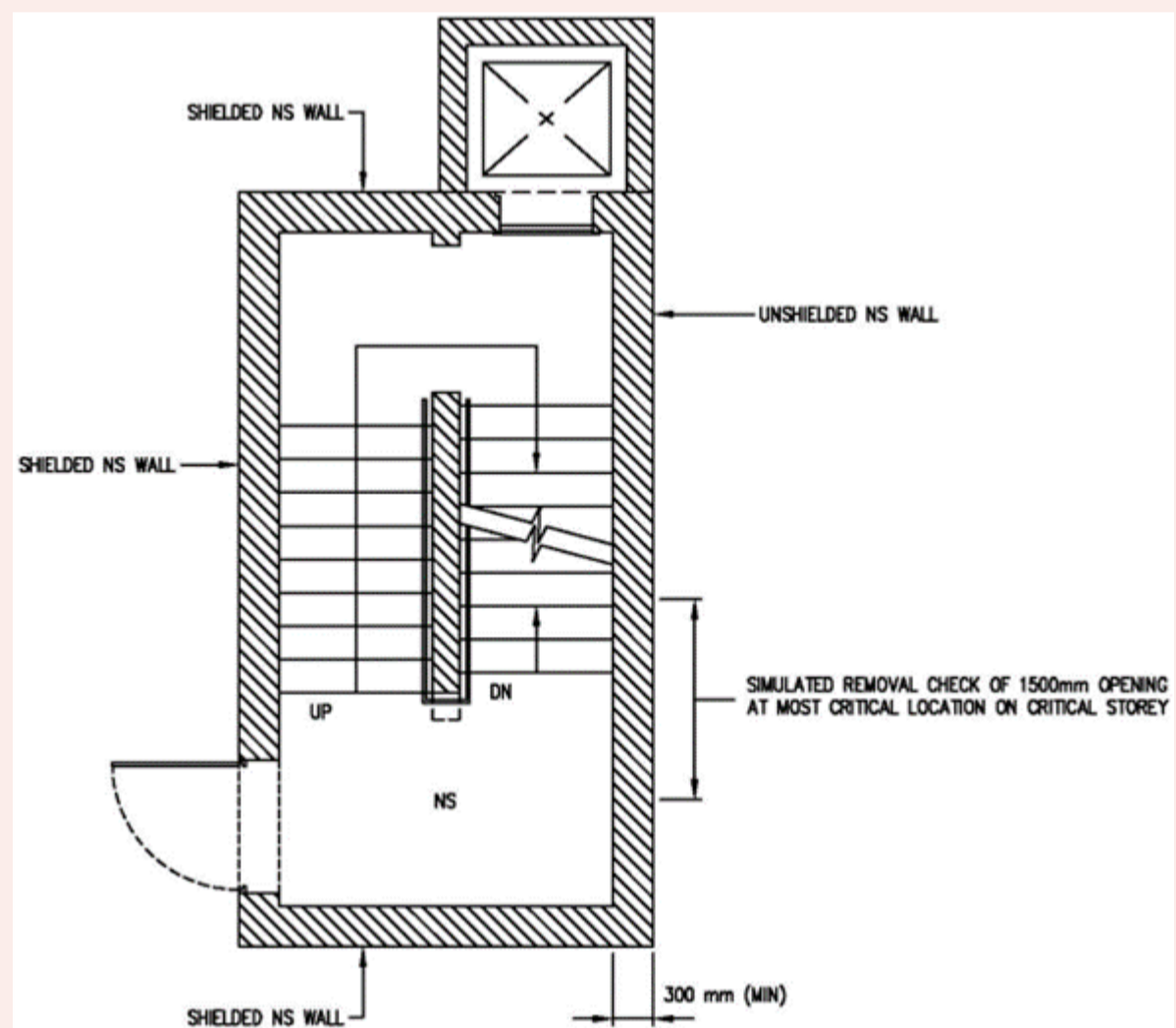

FIGURE 3.3.4(d): UNSHIELDED NS WALL OF S/C SS TOWER



- i. The design shall be based on the action combination and values of partial safety factor for actions in accordance with Table 3.3.4.
- ii. The design strength for a given material is derived from the characteristic strength divided by the partial safety factor for strength of material, which shall be 1.2 for concrete and 1.0 for reinforcements.

Figures & Tables

TABLE 3.3.4 : ACTION COMBINATION AND VALUES OF PARTIAL SAFETY FACTORS FOR ULTIMATE LIMIT STATE

Action Combination	Permanent Action		Variable Action		Earth/Water Pressure Load, if applicable
	Favourable	Unfavourable	Imposed Load	Wind Load	
Permanent and Variable (Imposed Load, Wind Load), Earth/Water Pressure Load, if applicable	1.0	1.0	1.0	1.0	1.0

CLAUSE 3.4 MEMBER DIMENSIONS AND REINFORCEMENT REQUIREMENTS

3.4.1 Member Dimensions

The minimum member size of SS and NS shall be as stipulated in Chapter 2 - Architectural Design.

3.4.2 Reinforcement Requirements

All diameters of reinforcement specified hereinafter shall refer to minimum fabric mesh or bar diameters. All spacing of reinforcement specified hereinafter shall refer to maximum spacing of reinforcement in both directions.

3.4.2.1 Wall Reinforcements of SS and NS

a. Minimum Reinforcement in SS or NS walls - refer to TABLE 3.4.2.1.

Figures & Tables

TABLE 3.4.2.1 : MINIMUM REINFORCEMENTS OF SS OR NS WALLS

SS/NS Clear Height (mm)	Reinforcement at both internal and external face of wall (both directions)	Shear Links (both directions)
2400 < Ht ≤ 3400	H13 - 100 c/c	H8 - 600 c/c
3400 < Ht ≤ 3900	H16 - 100 c/c	H8 600 c/c

b. Reinforcements at both faces of the internal common wall shall be H10-100 c/c in both faces. The shear links shall be H8-600 c/c in both directions.

c. Shielding wall in front of SS door:

Reinforcements at both faces of the wall shall be minimum H10-200 c/c. The shear link with L-bend at two ends shall be H8 at 600 c/c in both directions.

3.4.2.2 Reinforcements of SS and NS slabs

a. Intermediate SS/NS slabs and slabs/waists of staircase SS/NS:

Top and bottom layer of slab reinforcements shall be H10-100 c/c in both directions. The shear links shall be H8-600 c/c in both directions.

b. Ceiling slab of top-most SS:

i. Reinforcements at both external face and internal face of the slab shall be H13- 100 c/c (both directions).

ii. The shear links shall be H8-600 c/c in both directions.

c. Floor slab of bottom-most SS or NS and floor slab of NS located above a SS:

i. Slab reinforcements at both external face and internal face shall be H13-100 c/c (both directions).

ii. The shear links shall be H8-600 c/c in both directions.

d. Ceiling slab outside the SS tower which is immediately above SS door:

The minimum ceiling slab shall be constructed of 150mm thick reinforced concrete. The reinforcement shall consist of two layers of reinforcement (top and bottom) at H10-100 c/c in both directions. These top and bottom layers of reinforcement bars shall be continuous or anchored to the slab of SS with tension anchorage length.

e. Floor slab outside SS tower:

The reinforcements of every floor slab immediately outside SS tower walls shall be structurally connected to the SS tower.

f. SS slab which is integrated with pile-cap/footing:

For SS slab integrated with the pile-cap or footing of 500mm thick or more, shear links is not required. The maximum spacing of main reinforcement shall be 200mm c/c.

CLAUSE 3.5 DETAILING OF SS TOWER

3.5.1 General

The SS tower is to be detailed to allow for the installation of services and fixtures in SS and to resist spalling of the internal face of SS walls, soffit of ceiling slabs and/or finishes on SS floor slab.

3.5.2 Lap and Anchorage Length

- a. Full lap and anchorage length of reinforcements in SS and NS walls and slabs shall be provided. The lap length shall take into account good or poor bond condition, steel bar diameter, shape of steel bar, concrete cover, steel strength and location where reinforcement bar laps and confinement of transverse bars.
- b. Minimum tension lap and anchorage length of reinforcement bars for minimum concrete grade C32/40 with good bond condition shall be as shown in TABLE 3.5.2. Longer tension lap and anchorage length shall be provided if they are required to meet poor bond condition and/or the structural load and safety requirements.

Figures & Tables

TABLE 3.5.2 : MINIMUM TENSION LAP AND ANCHORAGE LENGTH

Type	Reinforcement Bar Diameter \varnothing (mm)	
	$10 \leq \varnothing \leq 16$	$16 \leq \varnothing \leq 32$
Lap Length	$47\varnothing$	$52\varnothing$
Anchorage Length	$37\varnothing$	$37\varnothing$

- c. Welding of reinforcement to attain full anchorage length and tension lap length is not permitted.
- d. Bundled bars are not permitted.

3.5.3 Concrete Cover

The minimum and maximum concrete cover to the main reinforcements shall be 25mm and 40mm respectively.

3.5.4 Cast-In-Situ Elements for SS and S/C SS

Cast-In-Situ for SS elements shall comply with the dimensions and detailed requirements as shown in the following figures:

Figures & Tables

FIGURE 3.5.4(a): PLAN OF SS WALL

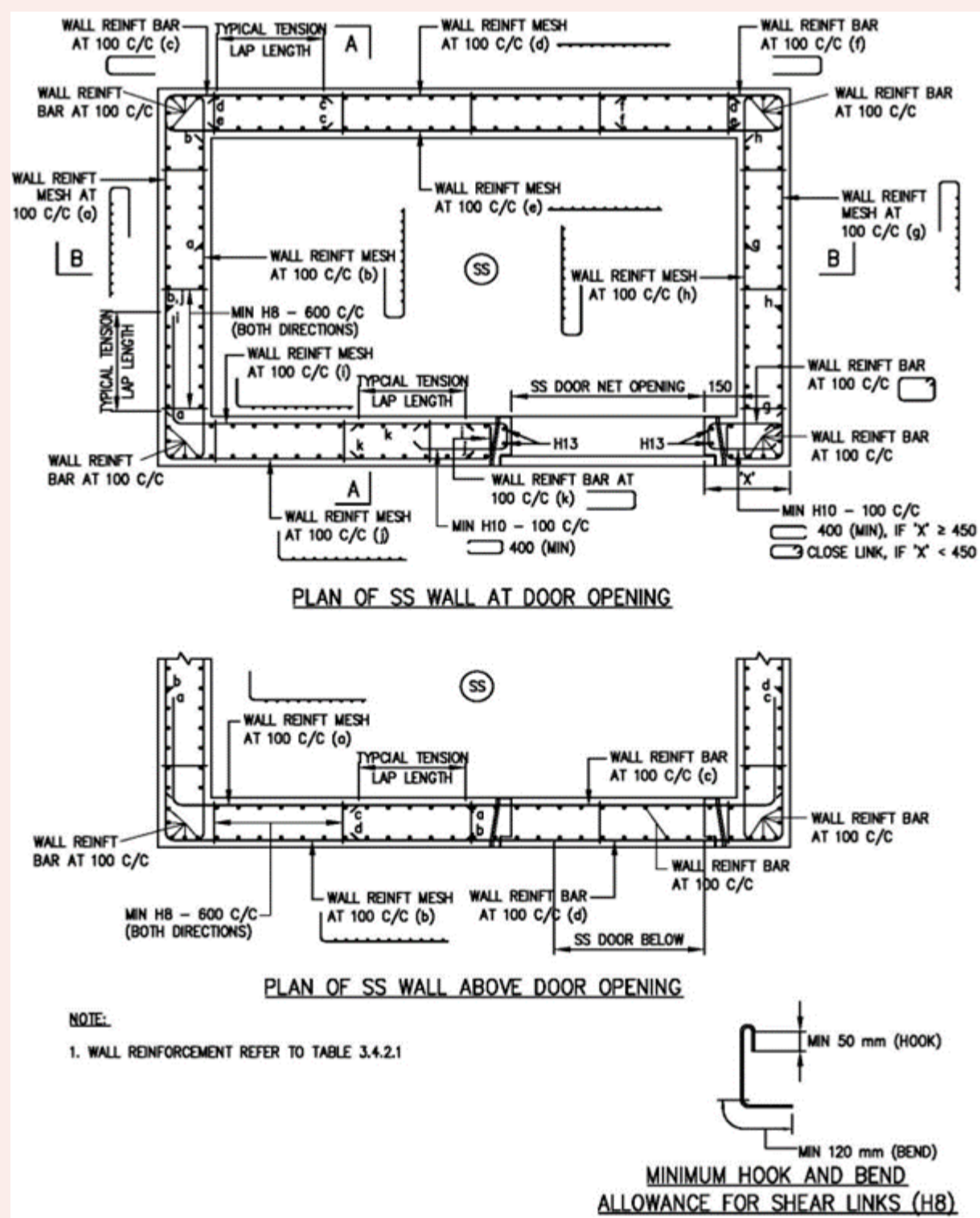

FIGURE 3.5.4(b): SECTIONAL DETAILS OF SS SLABS/ WALLS

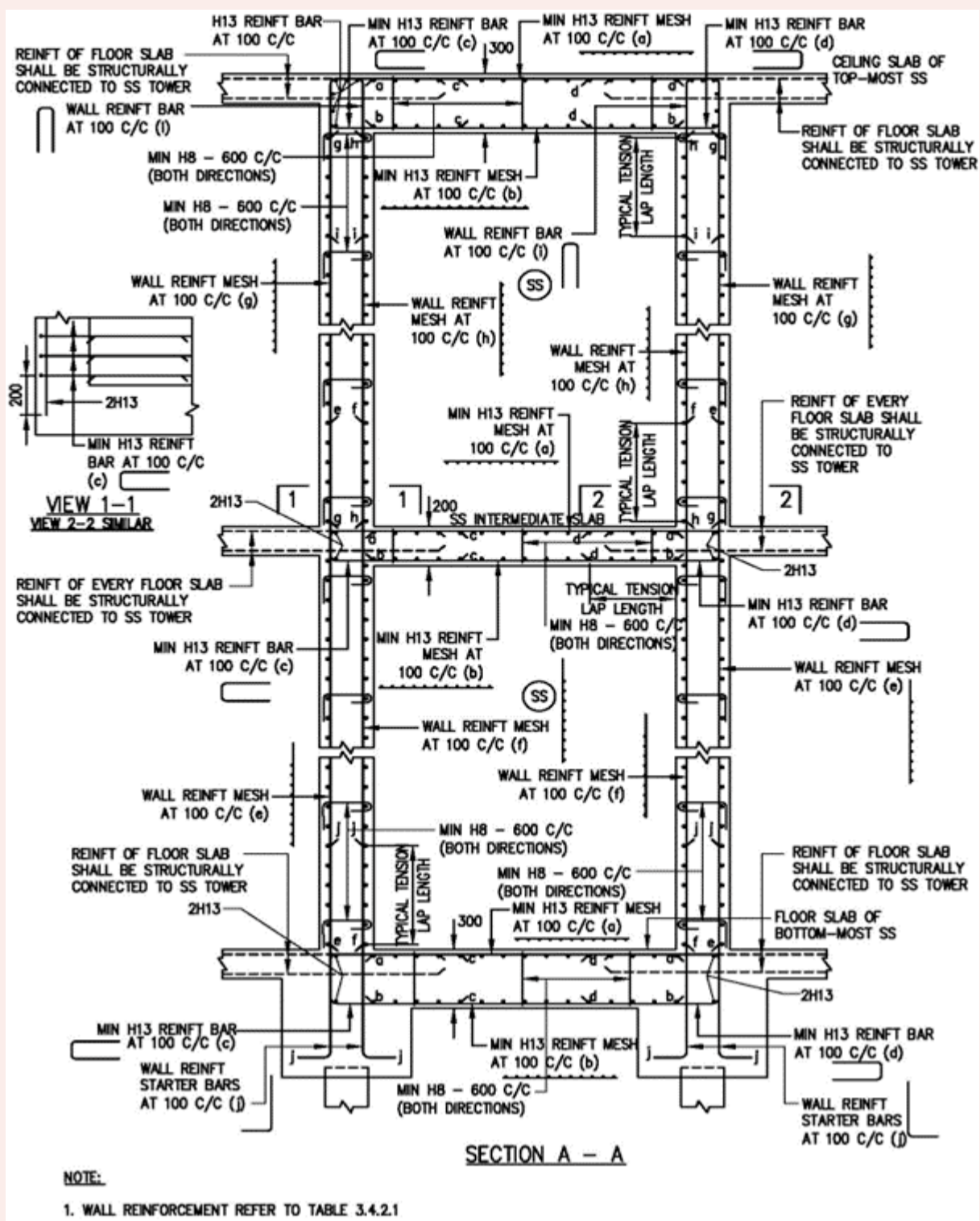

FIGURE 3.5.4(c): SECTIONAL DETAILS OF SS SLABS/WALLS

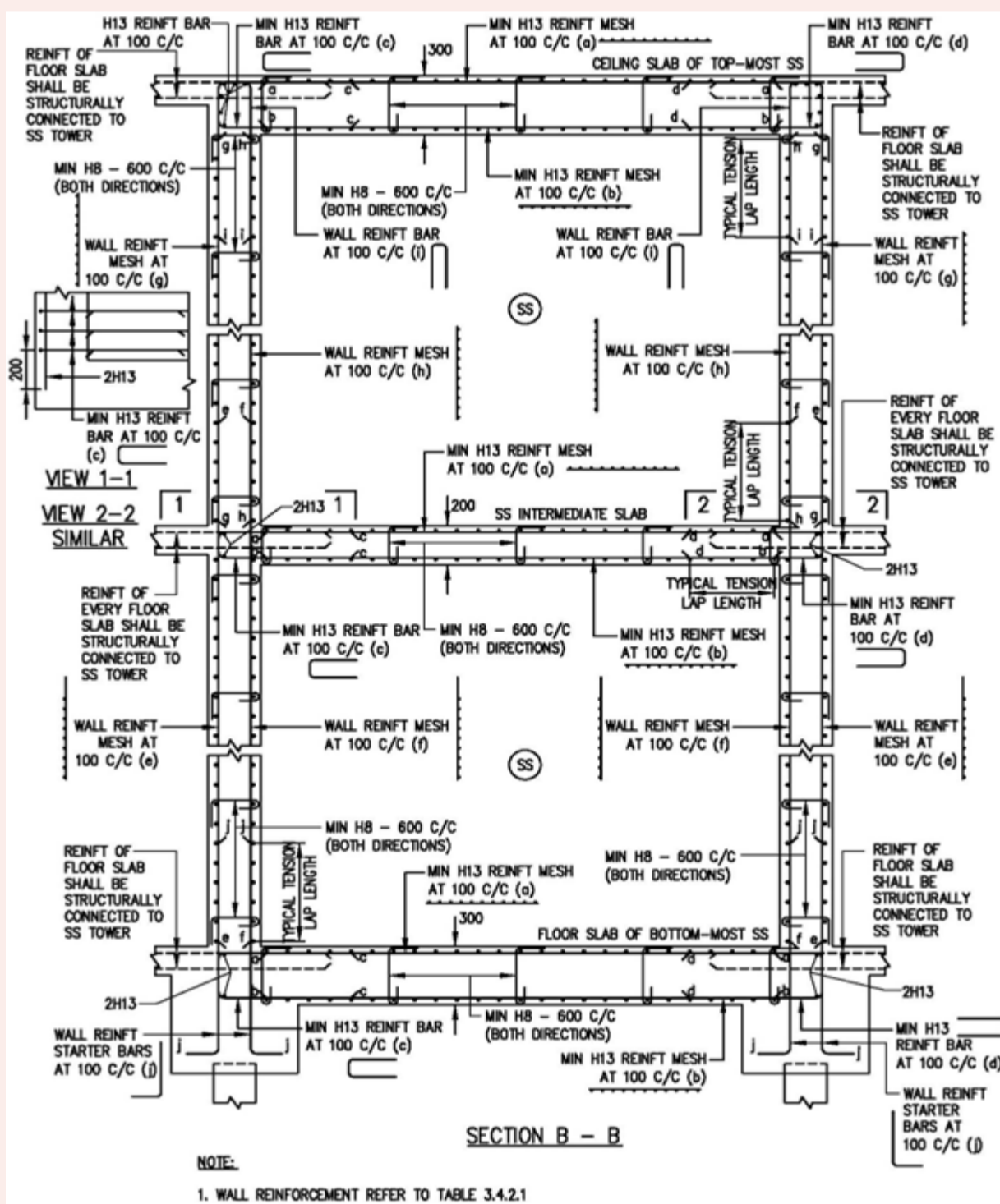

FIGURE 3.5.4(d)(i): DETAILS OF SS WALL REINFORCEMENT BARS NEAR SS DOOR

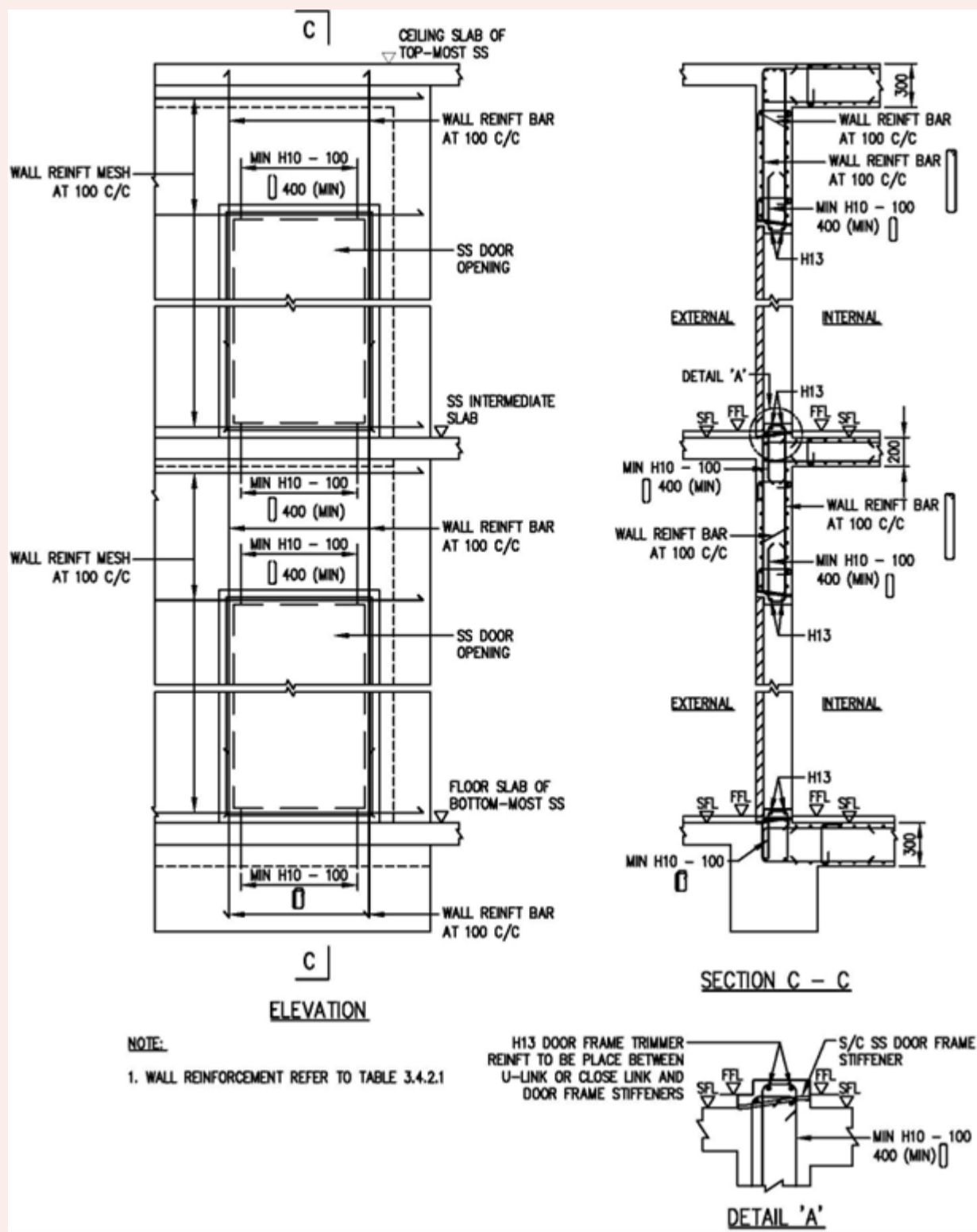

FIGURE 3.5.4(d)(ii): DETAILS OF SS WALL REINFORCEMENT BARS NEAR SS DOOR

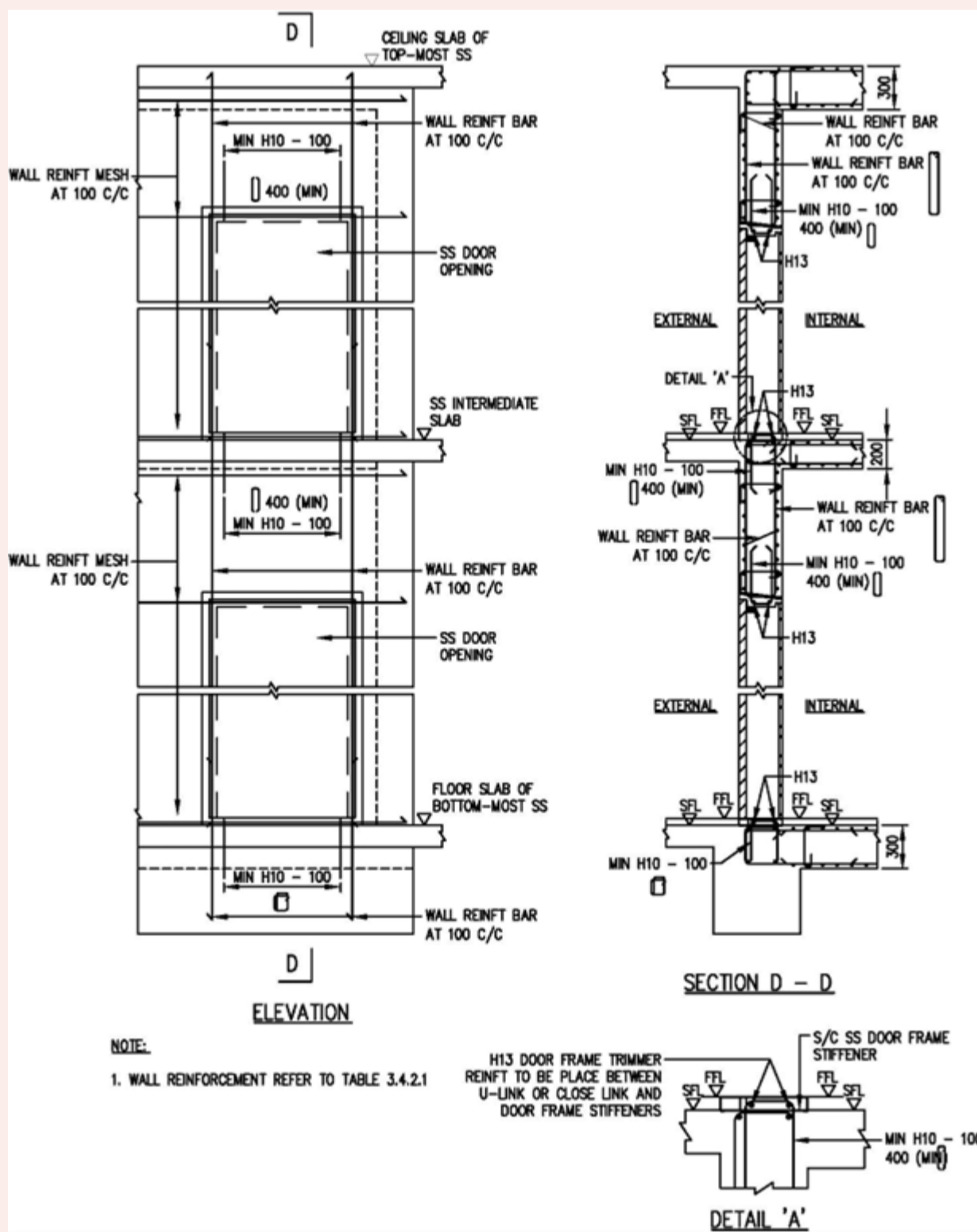
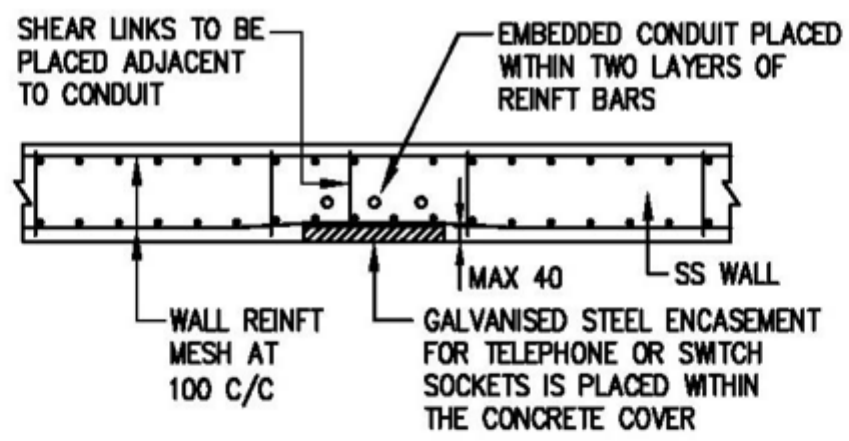
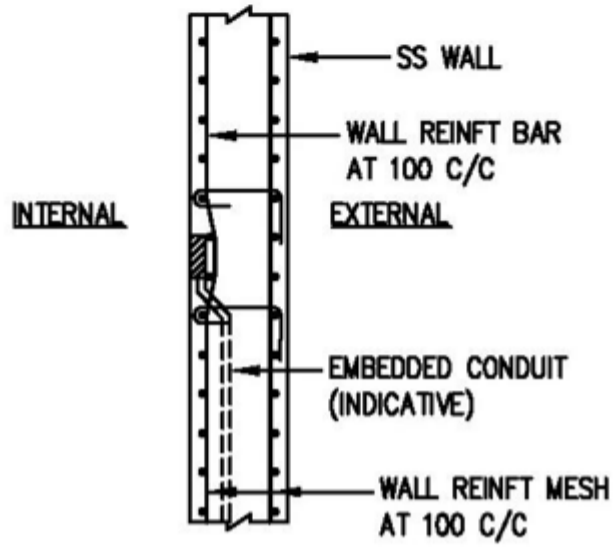

FIGURE 3.5.4(e): TYPICAL DETAILS OF EMBEDDED CONDUIT IN SS WALL



PLAN
(REINFORCEMENT BARS ARE NOT CUT)



SECTION 1 - 1

NOTE:
1. WALL REINFORCEMENT REFER TO TABLE 3.4.2.1

FIGURE 3.5.4(f): TYPICAL DETAILS OF TRIMMER BARS FOR VENTILATION SLEEVE

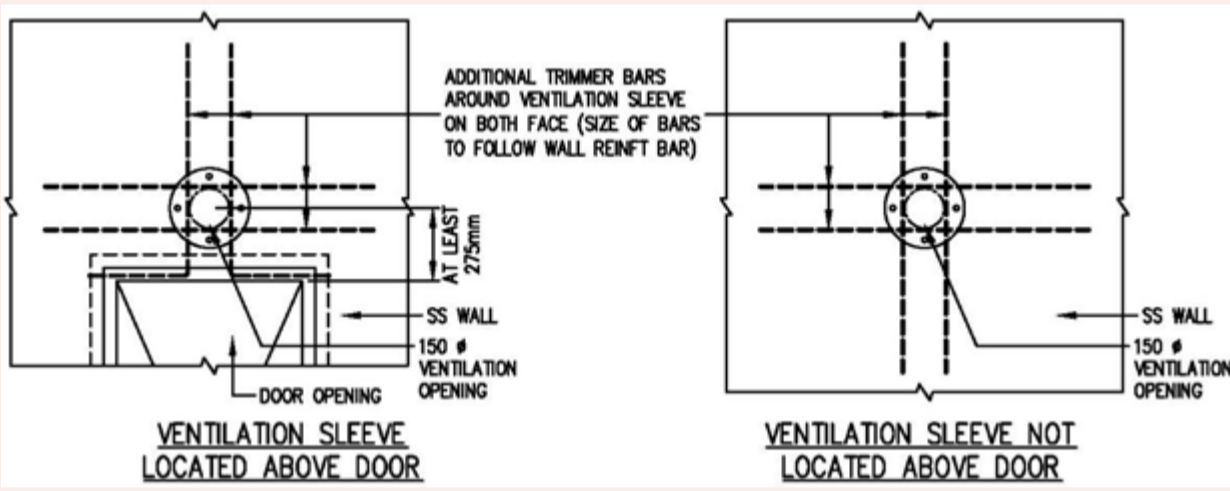

FIGURE 3.5.4(g): TYPICAL DETAILS OF REINFORCEMENT BARS AT WALL RECESS

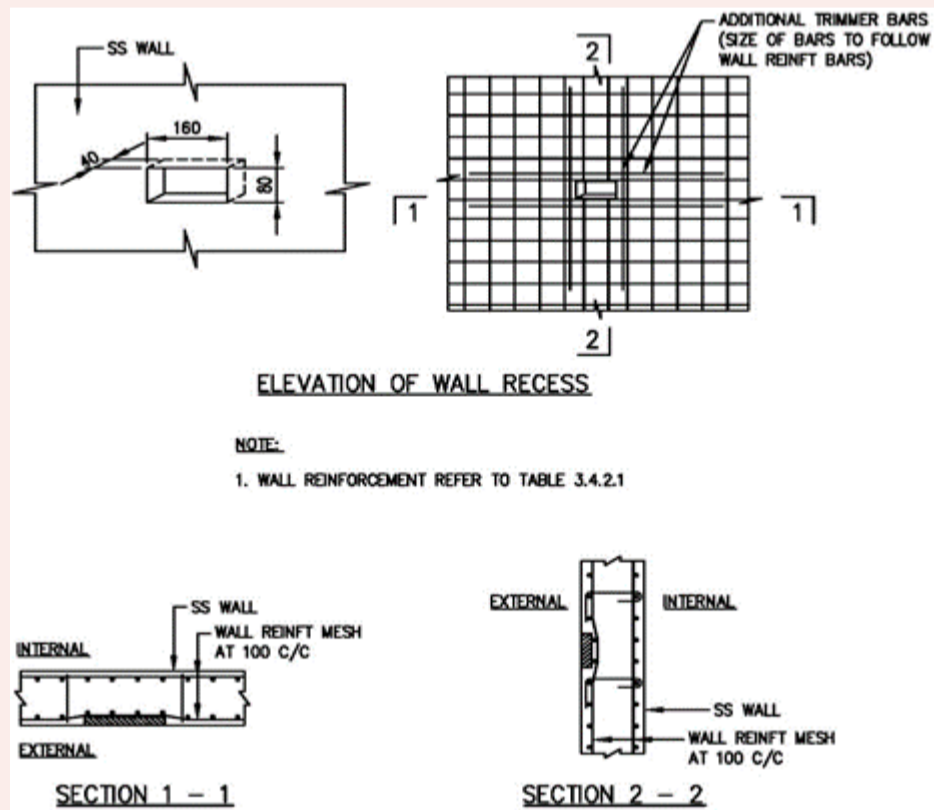

FIGURE 3.5.4(h): DETAILS OF SHEAR LINKS IN SS SLABS/ WALLS

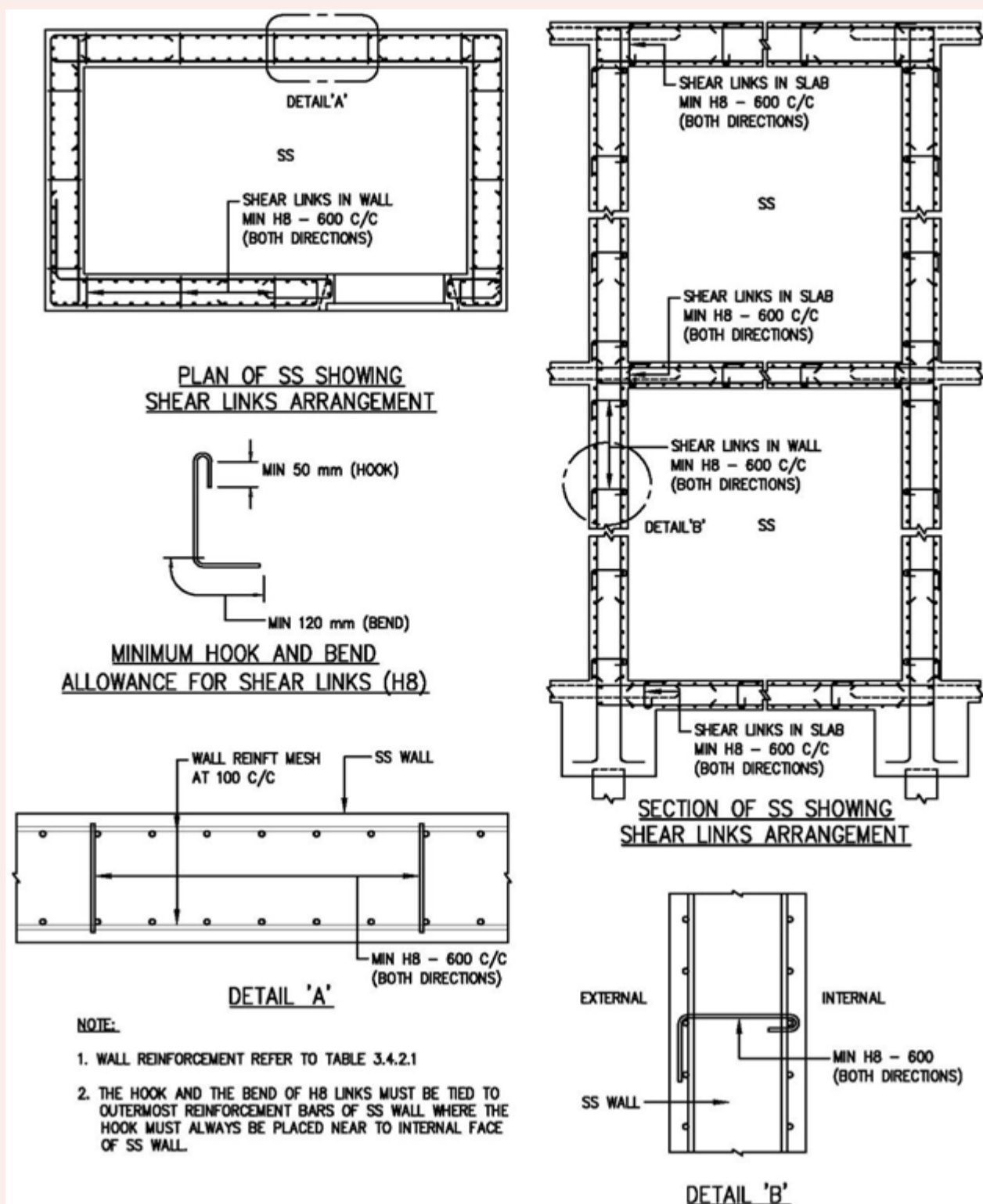

FIGURE 3.5.4(i): DETAILS OF SS SLAB REINFORCEMENT NEAR RESCUE HATCH

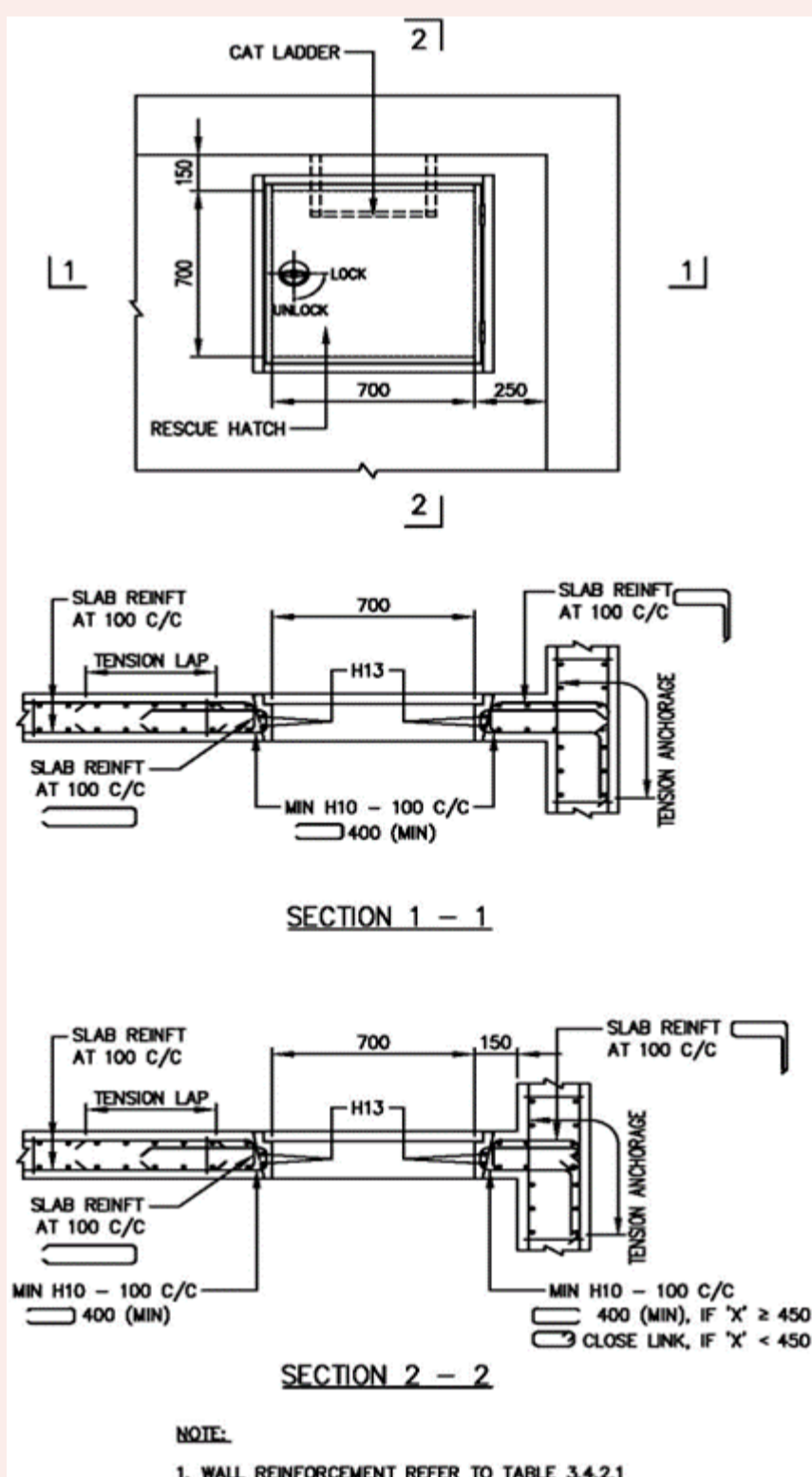

FIGURE 3.5.4(j): REINFORCEMENT PLAN DETAILS FOR S/C SS

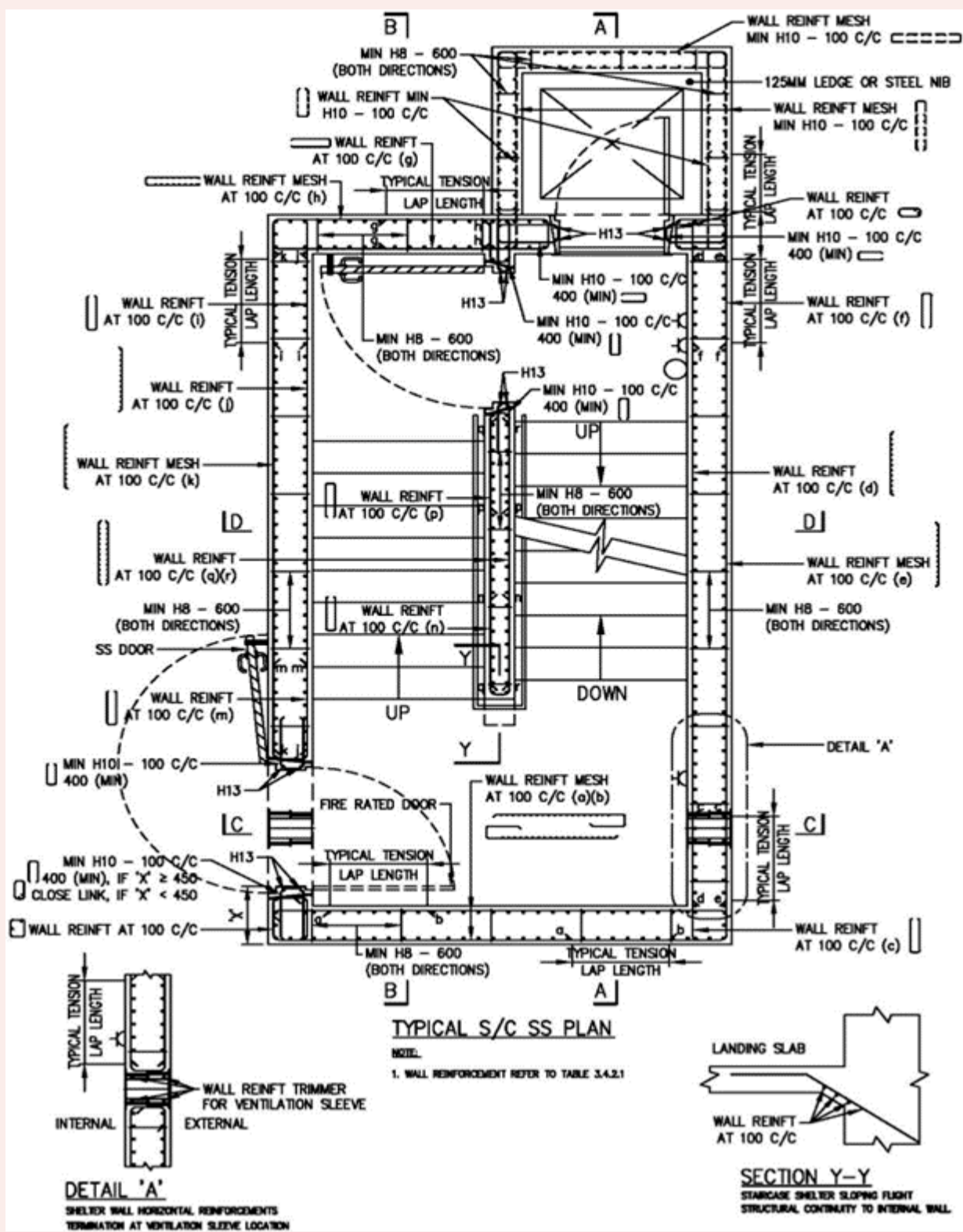

FIGURE 3.5.4(k): SECTIONAL DETAILS OF SS SLABS/ WALLS FOR S/C SS

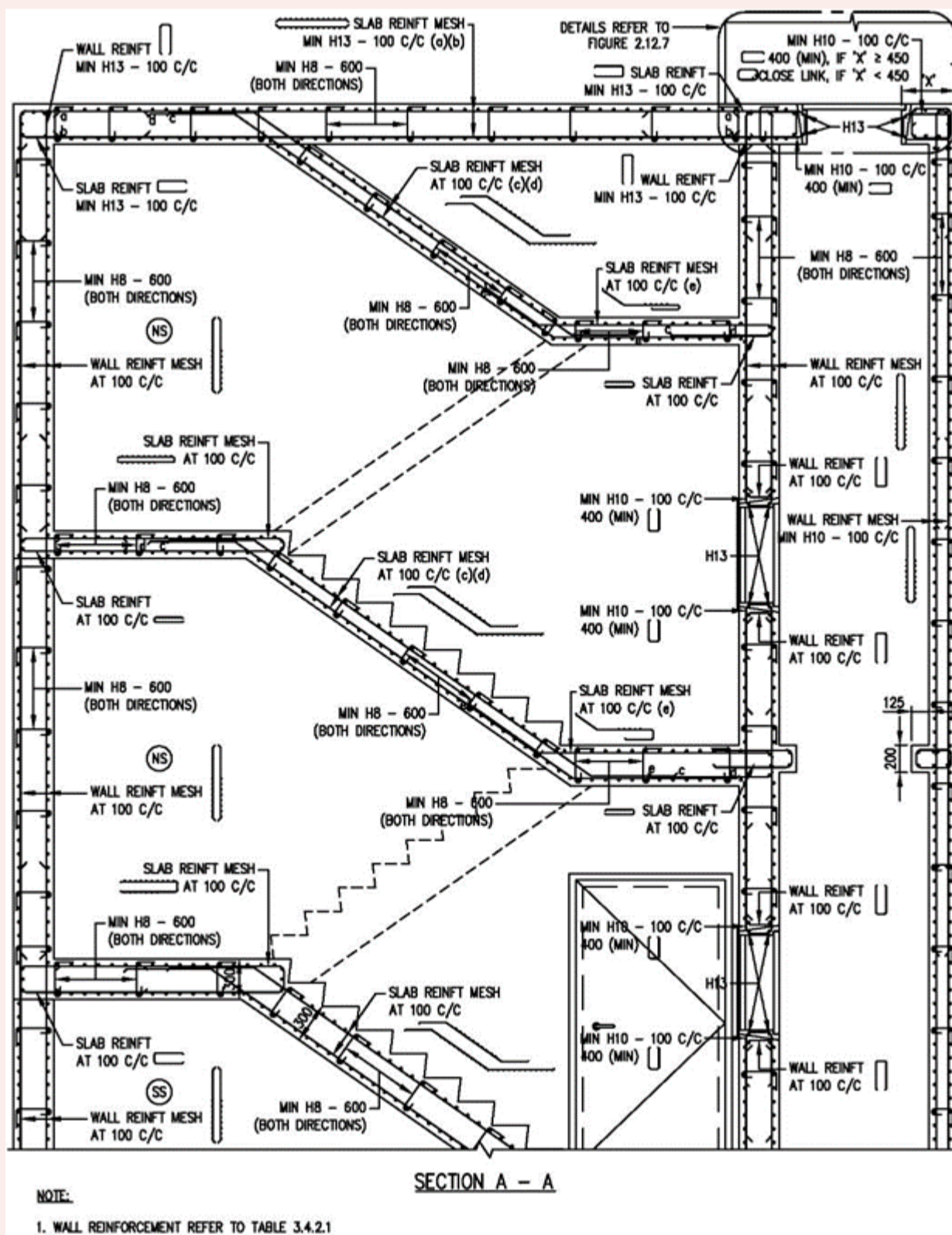
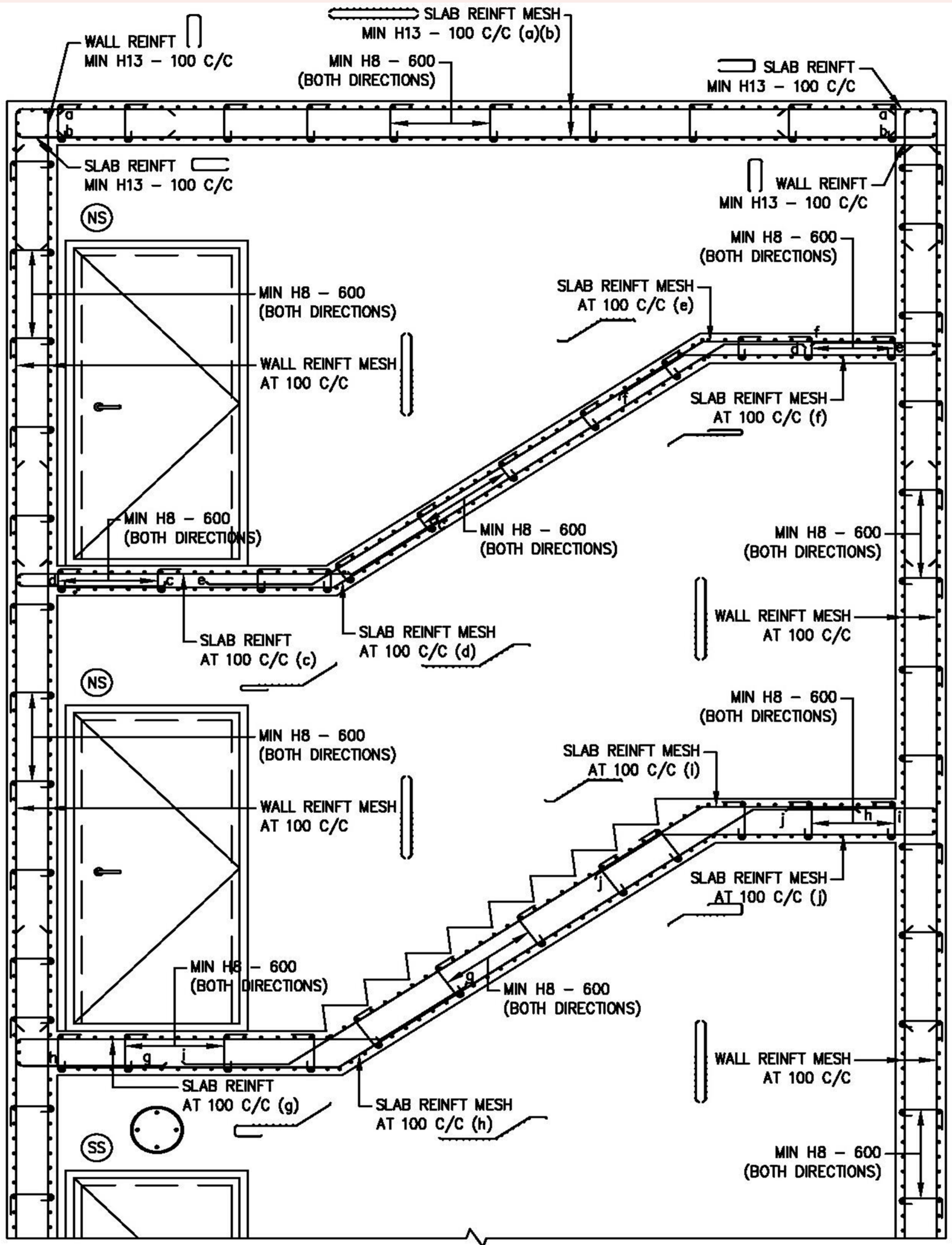

FIGURE 3.5.4(l): SECTIONAL DETAILS OF SS SLABS/ WALLS FOR S/C SS



SECTION B - B

NOTE:

1. WALL REINFORCEMENT REFER TO TABLE 3.4.2.1

FIGURE 3.5.4(m): SECTIONAL DETAILS OF SS SLABS/ WALLS FOR S/C SS

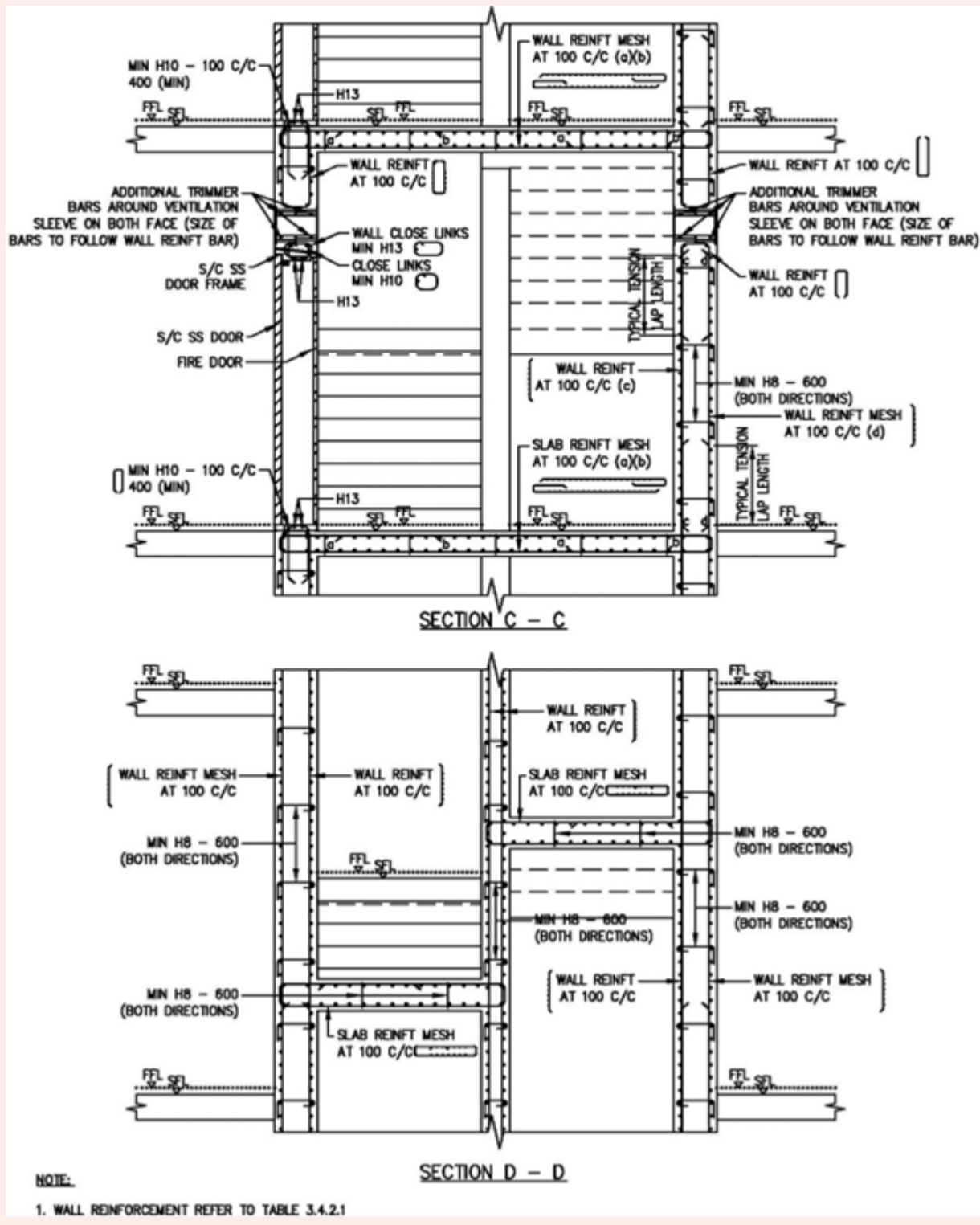

3.5.4 Cast-In-Situ Elements for SS and S/C SS

FIGURE 3.5.4(a)	Plan of SS wall
FIGURE 3.5.4(b)	Sectional details of SS slabs/walls
FIGURE 3.5.4(c)	Sectional details of SS slabs/walls
FIGURE 3.5.4(d)(i)	Details of SS wall reinforcement bars near SS door
FIGURE 3.5.4(d)(ii)	Details of S/C SS wall reinforcement bars near S/C SS door
FIGURE 3.5.4(e)	Typical details of embedded conduit in SS wall
FIGURE 3.5.4(f)	Typical details of trimmer bars for ventilation sleeve
FIGURE 3.5.4(g)	Typical details of reinforcement bars at wall recess
FIGURE 3.5.4(h)	Details of shear links in SS slabs/walls
FIGURE 3.5.4(i)	Details of SS slab reinforcement near rescue hatch
FIGURE 3.5.4(j)	Reinforcement plan details for S/C SS
FIGURE 3.5.4(k)	Sectional details of SS slabs/walls for S/C SS
FIGURE 3.5.4(l)	Sectional details of SS slabs/walls for S/C SS
FIGURE 3.5.4(m)	Sectional details of SS slabs/walls for S/C SS

3.5.5 Precast Elements for SS and S/C SS

Pre-cast SS elements shall comply with the dimensions and detailed requirements as shown in the following figure:

Figures & Tables

FIGURE 3.5.5(a): PLAN OF SS WALLS WITH PRECAST SS DOOR FRAME PANEL (TYPE 1)

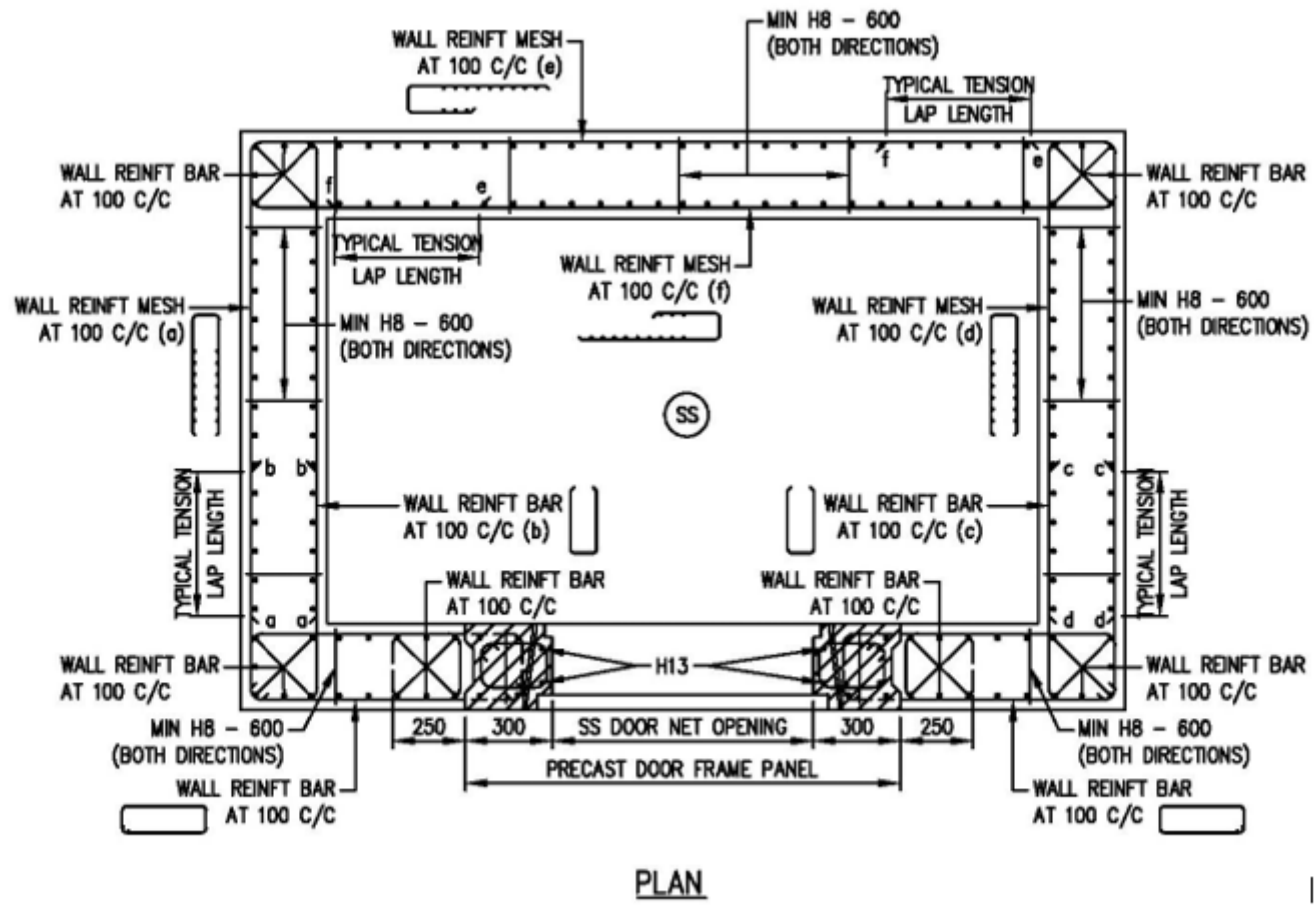

PLAN

NOTE:

1. WALL REINFORCEMENT REFER TO TABLE 3.4.2.1
2. WALL REINFORCEMENTS AT VENTILATION SLEEVE LOCATION REFER TO FIGURE 3.5.5(i) & (ii)

FIGURE 3.5.5(b): DETAILS AND SECTIONS OF PRECAST SS DOOR FRAME PANEL WITH VENTILATION SLEEVE ABOVE IT (TYPE 1)

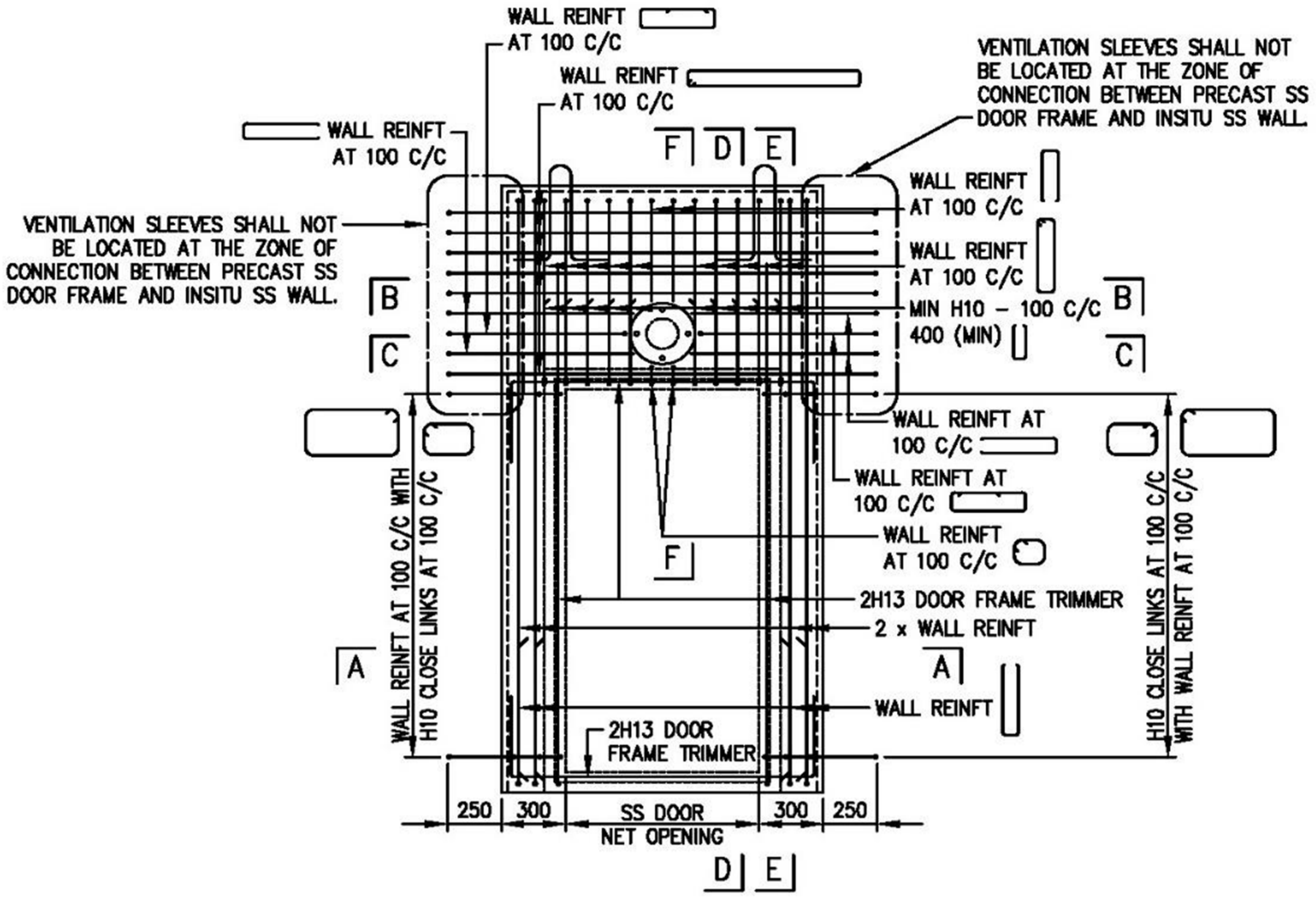

ELEVATION

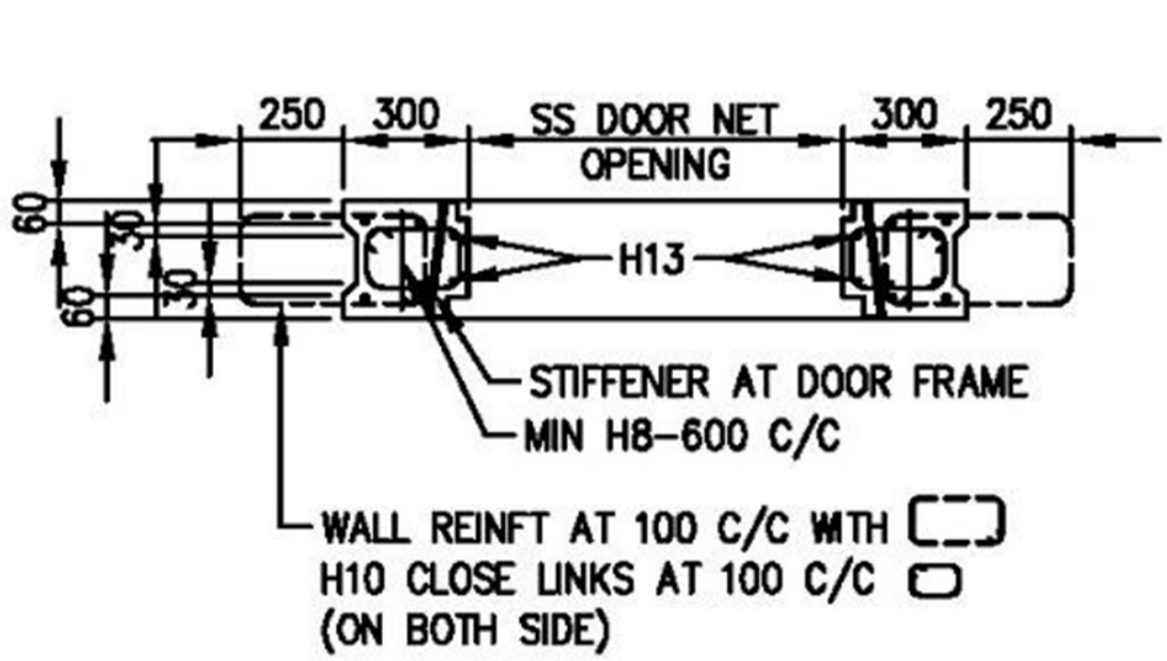

SECTION A - A

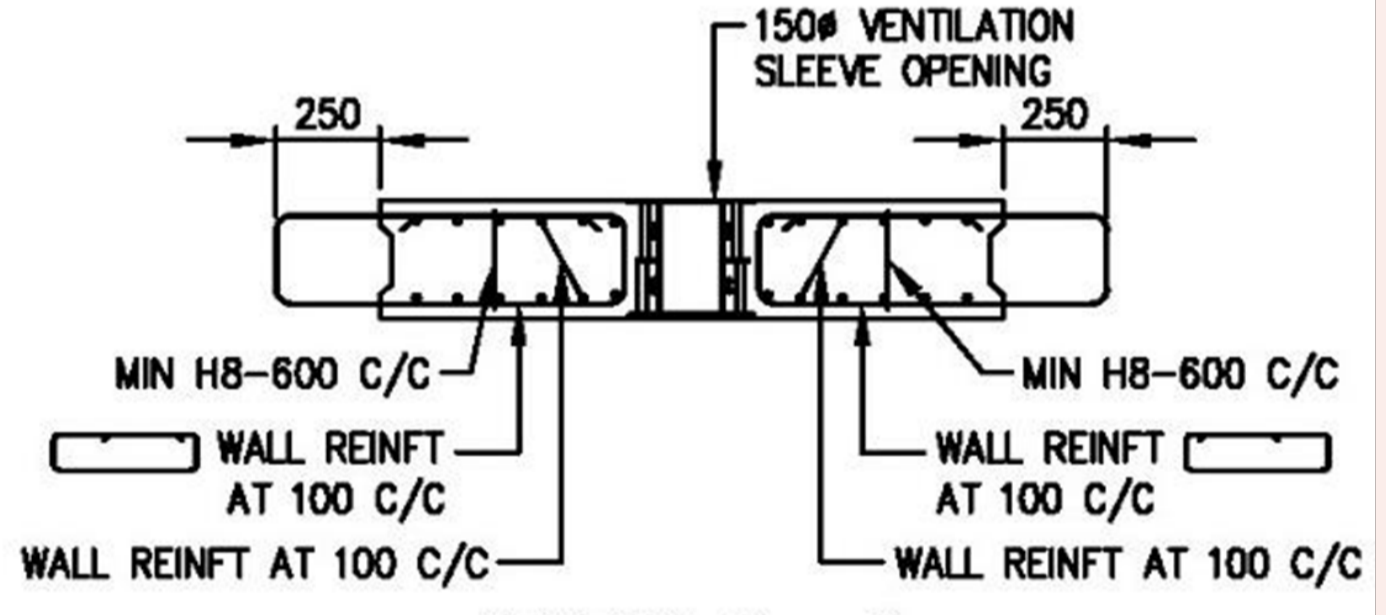

SECTION C - C

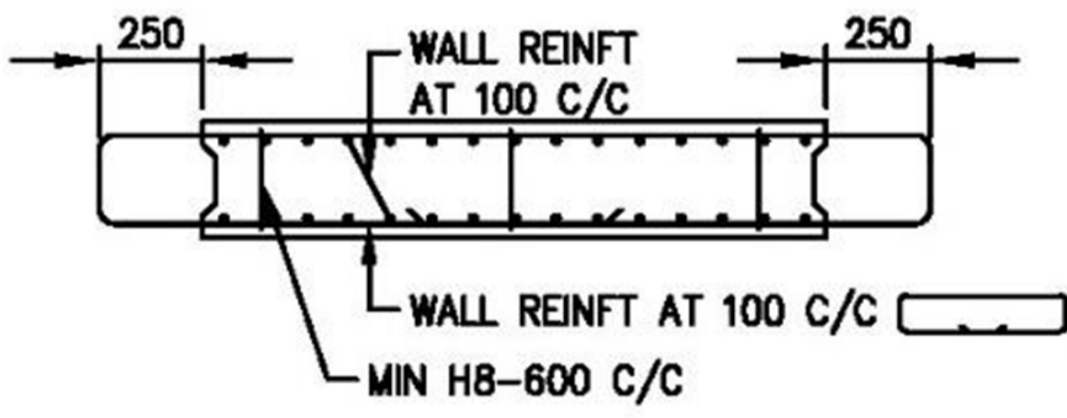

SECTION B - B

FIGURE 3.5.5(c): SECTIONS OF PRECAST SS DOOR FRAME PANEL WITH VENTILATION SLEEVE ABOVE IT (TYPE 1)

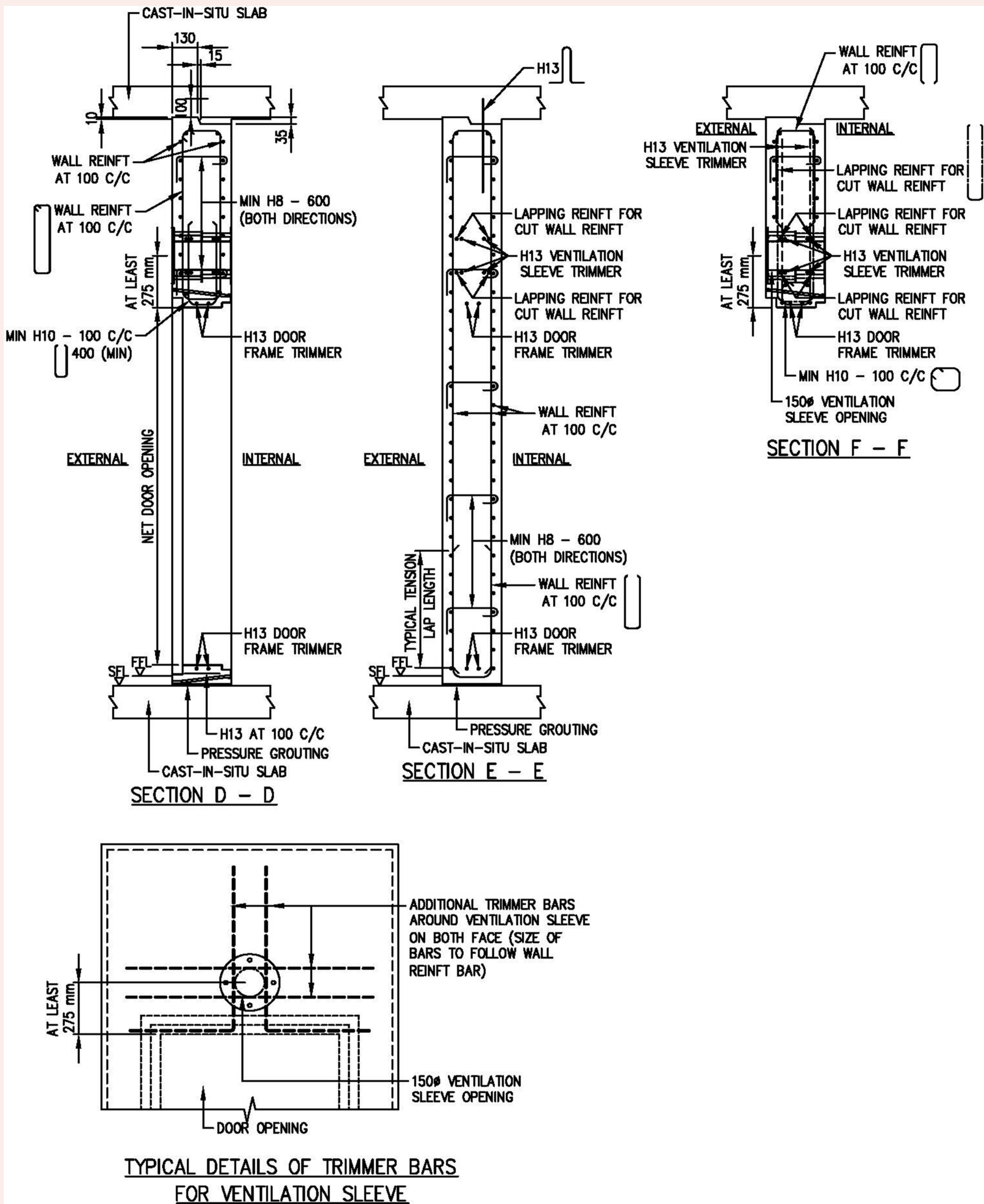
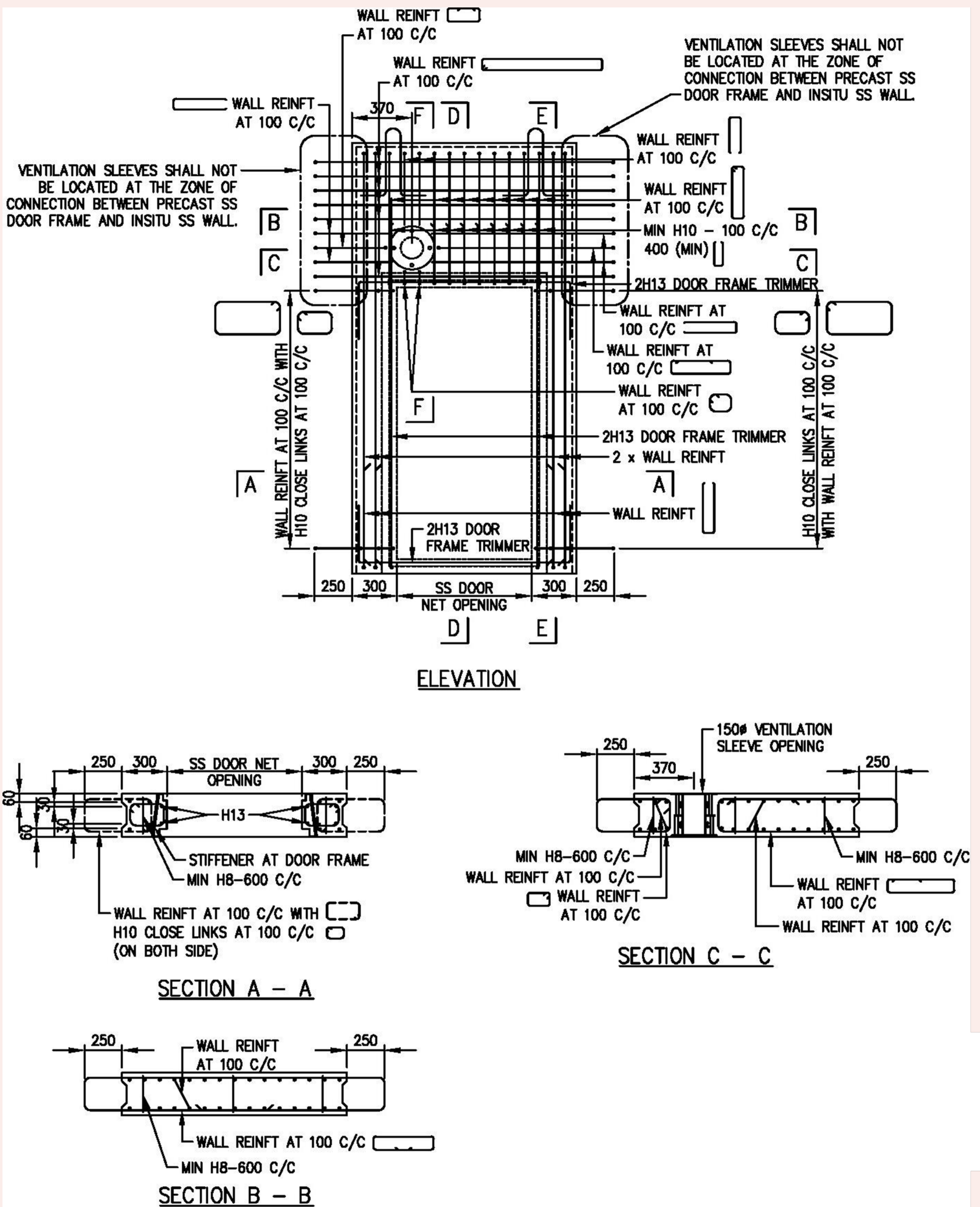

FIGURE 3.5.5(d): DETAILS AND SECTIONS OF PRECAST SS DOOR FRAME WITH VENTILATION SLEEVE ALONG ITS SIDE (TYPE 1)



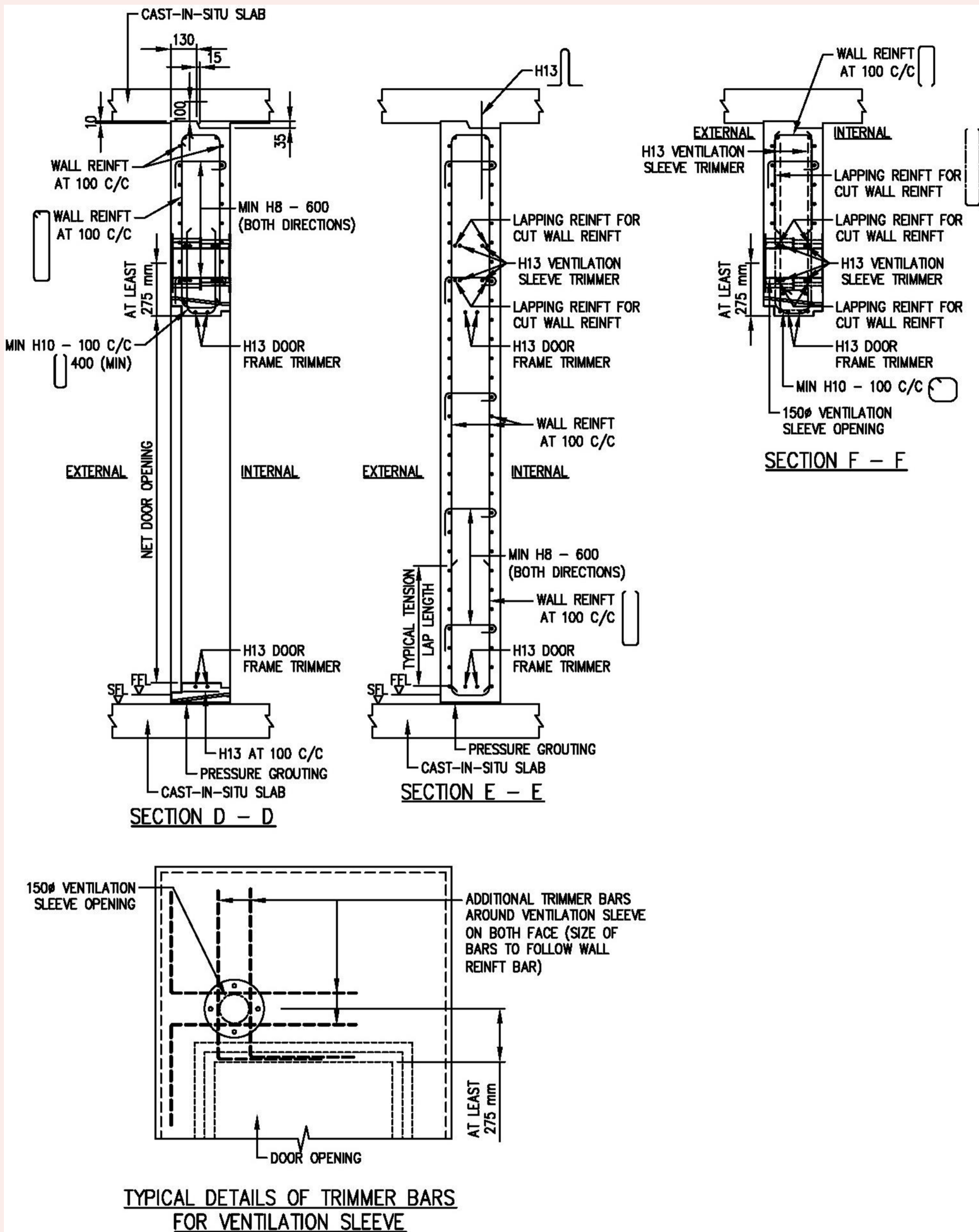
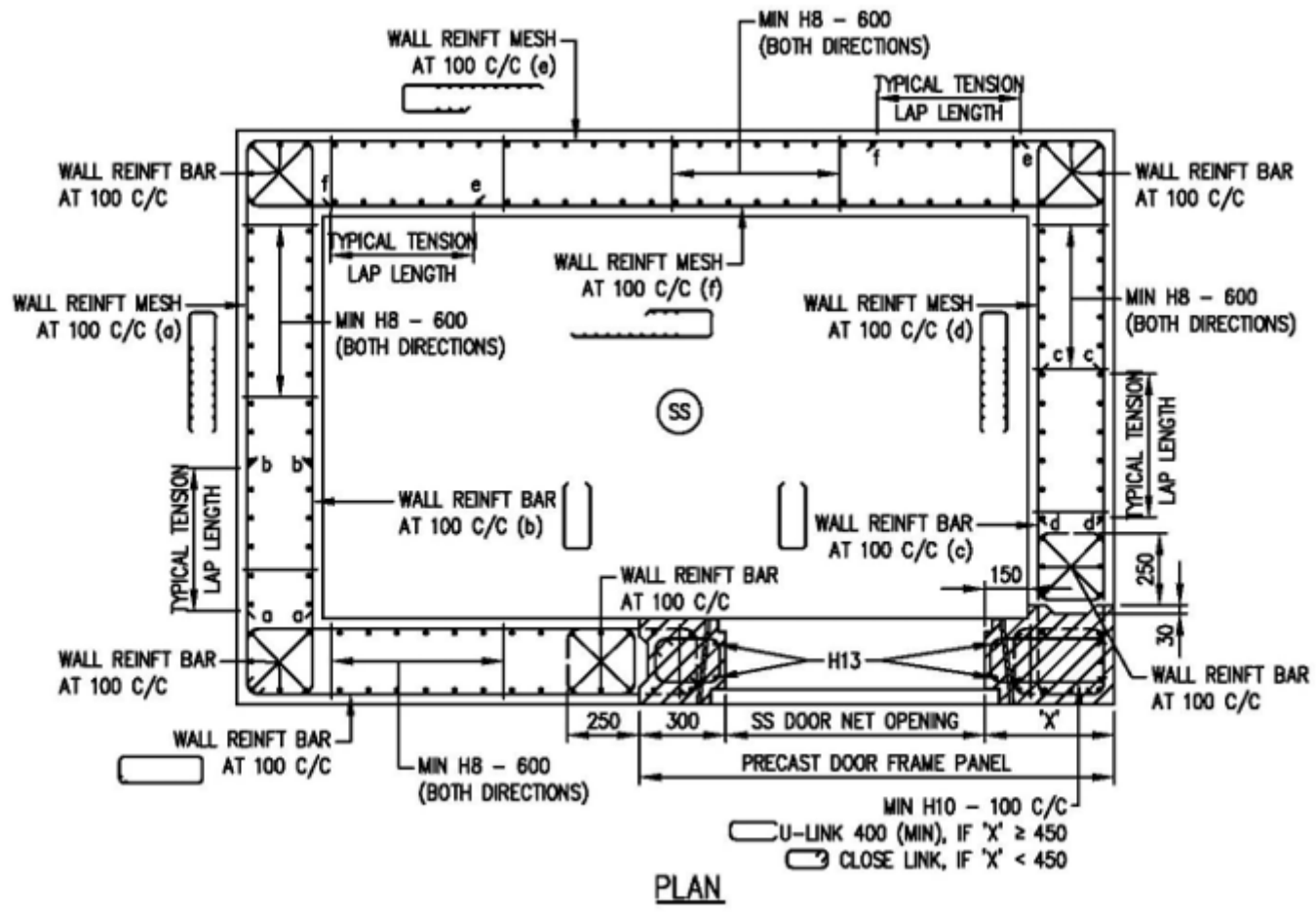

FIGURE 3.5.5(f): PLAN OF SS WALLS WITH PRECAST SS DOOR FRAME PANEL (TYPE 2)



NOTE:

1. WALL REINFORCEMENT REFER TO TABLE 3.4.2.1
2. WALL REINFORCEMENTS AT VENTILATION SLEEVE LOCATION REFER TO FIGURE 3.5.5(o)(i) & (ii)

FIGURE 3.5.5(g): PLAN OF SS WALLS WITH PRECAST SS DOOR FRAME PANEL (TYPE 2)

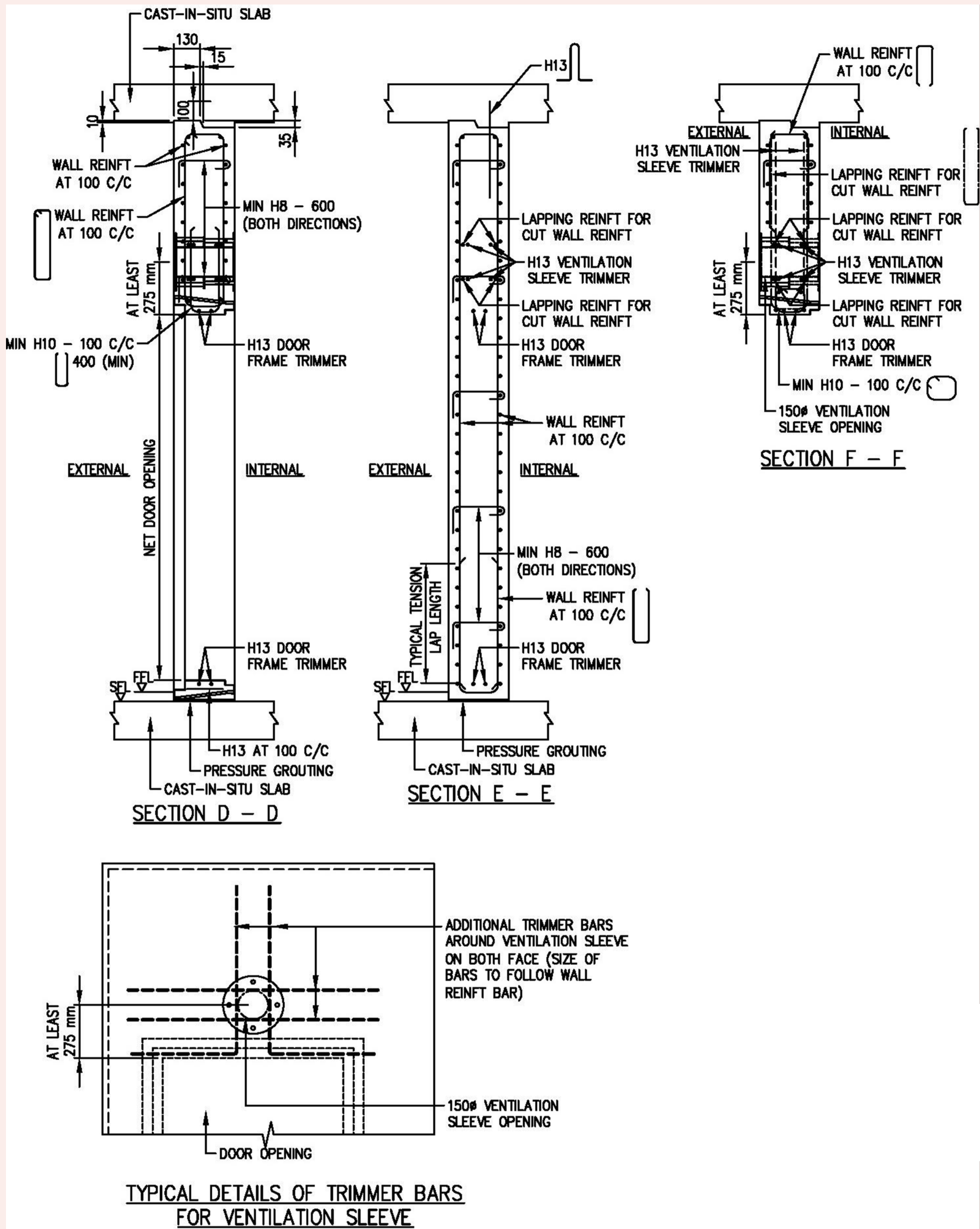
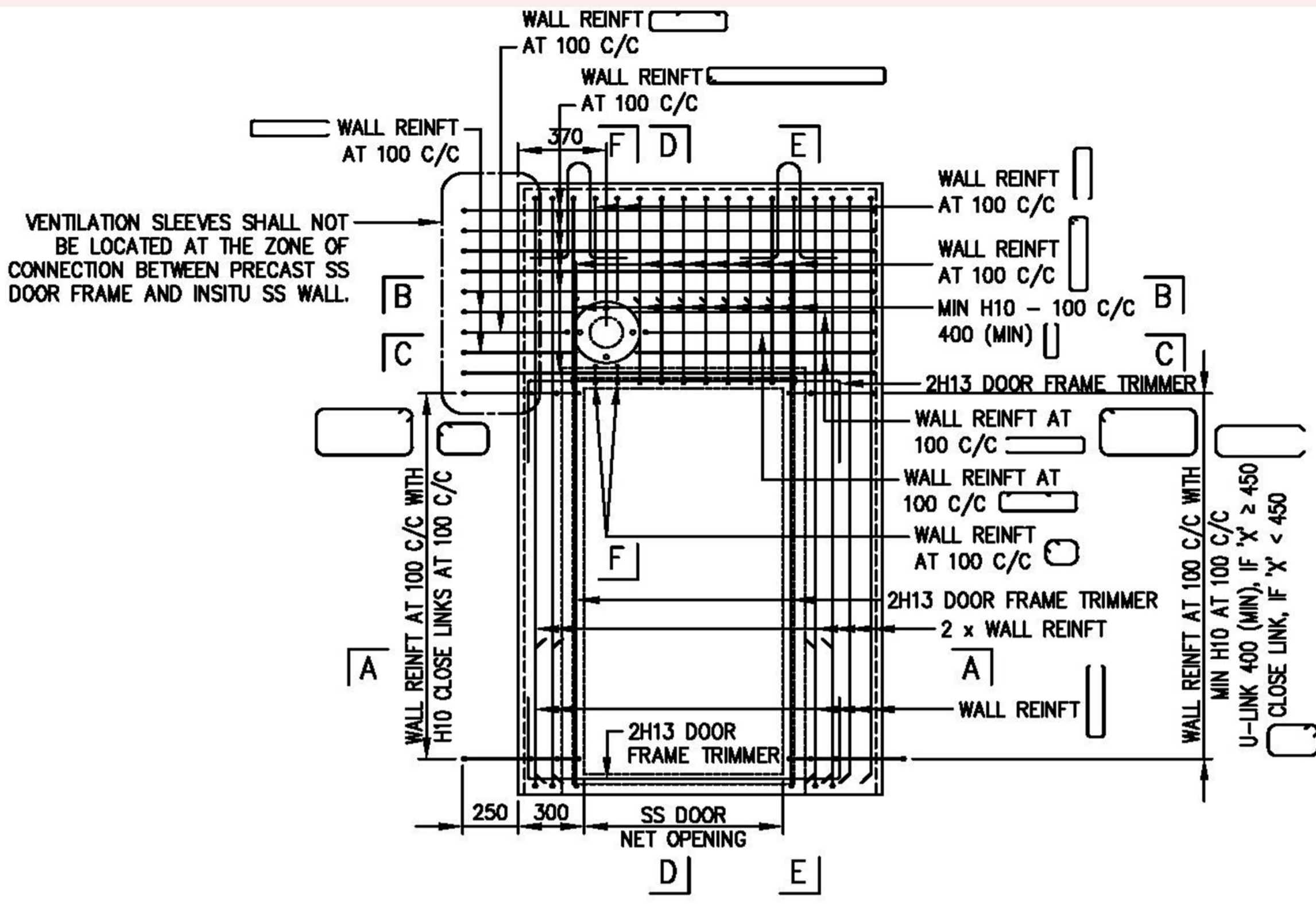
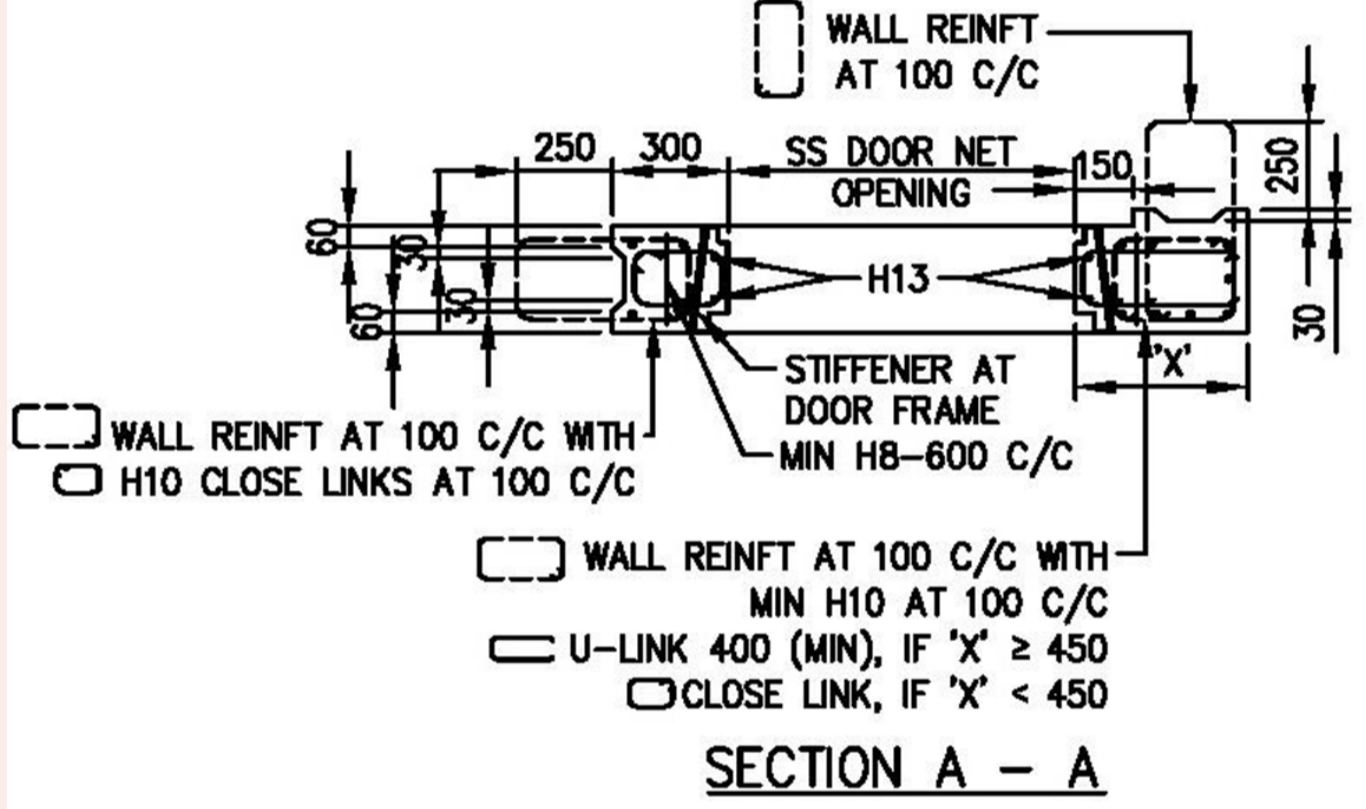

FIGURE 3.5.5(i): DETAILS AND SECTIONS OF PRECAST SS DOOR FRAME PANEL WITH VENTILATION SLEEVE ALONG ITS SIDE (TYPE 2)



ELEVATION



SECTION A - A

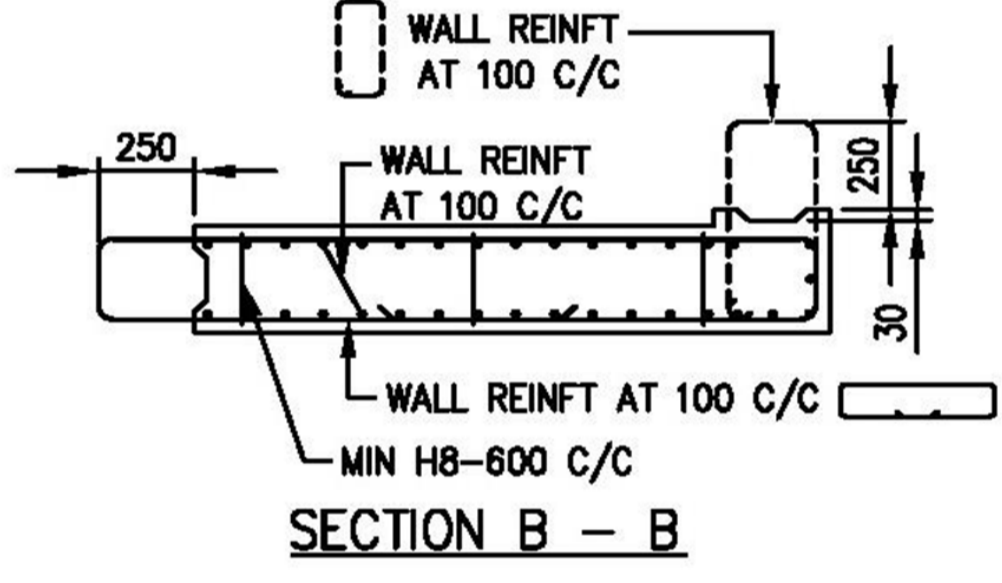

SECTION B - B

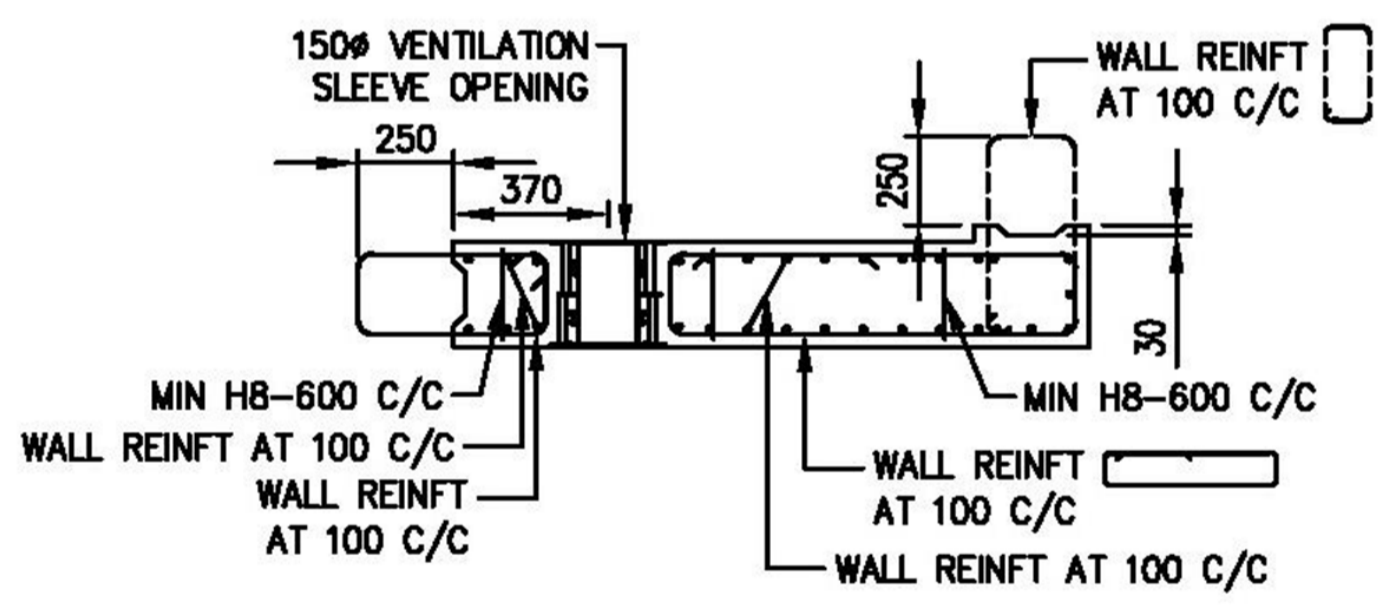

SECTION C - C

FIGURE 3.5.5(j): SECTIONS OF PRECAST SS DOOR FRAME PANEL WITH VENTILATION SLEEVE ALONG ITS SIDE (TYPE 2)

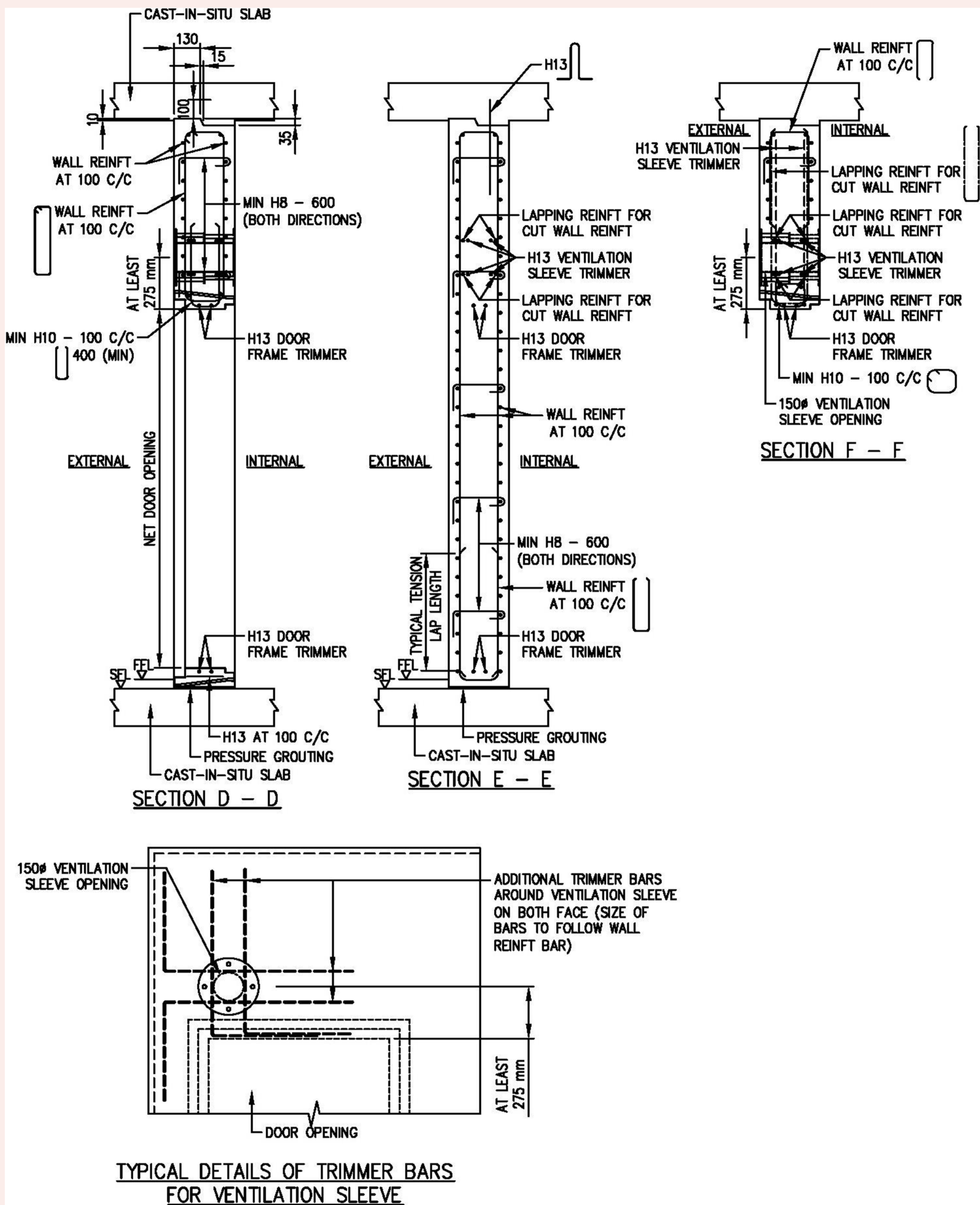

FIGURE 3.5.5(k) PLAN OF SS WALLS WITH PRECAST SS DOOR FRAME PANEL (TYPE 3)

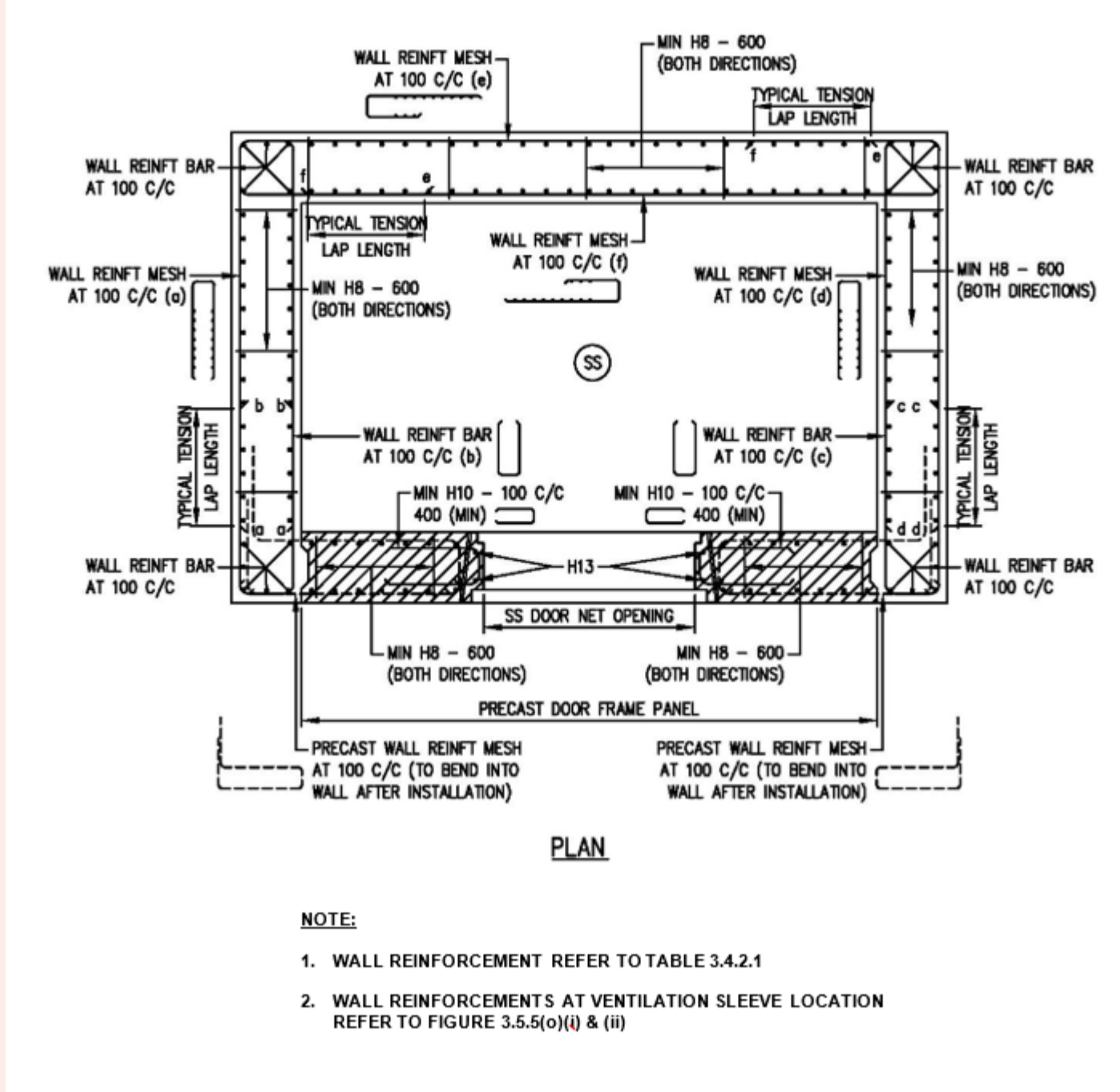

FIGURE 3.5.5(i): DETAILS OF PRECAST SS DOOR FRAME PANEL (TYPE 3)

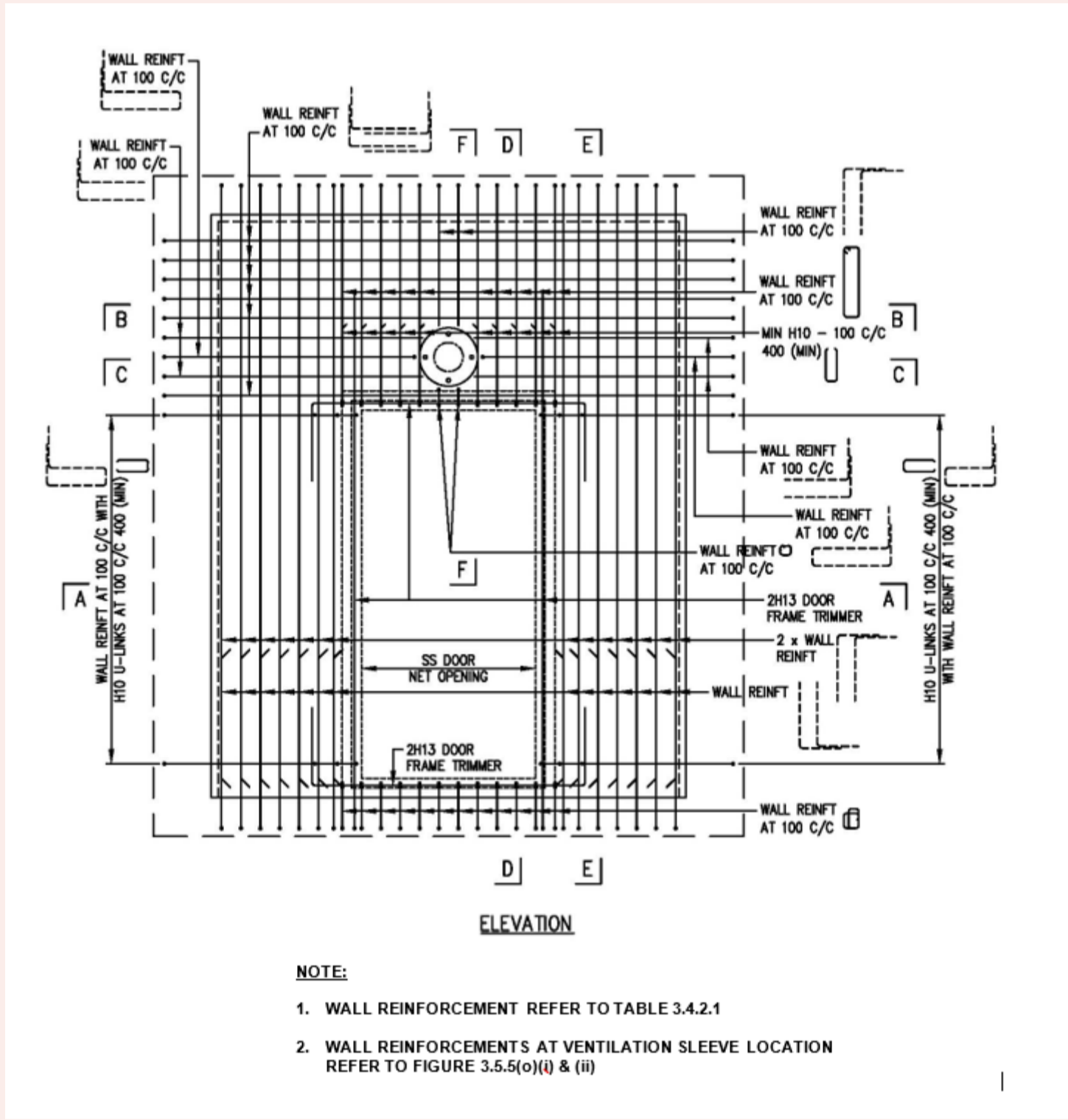
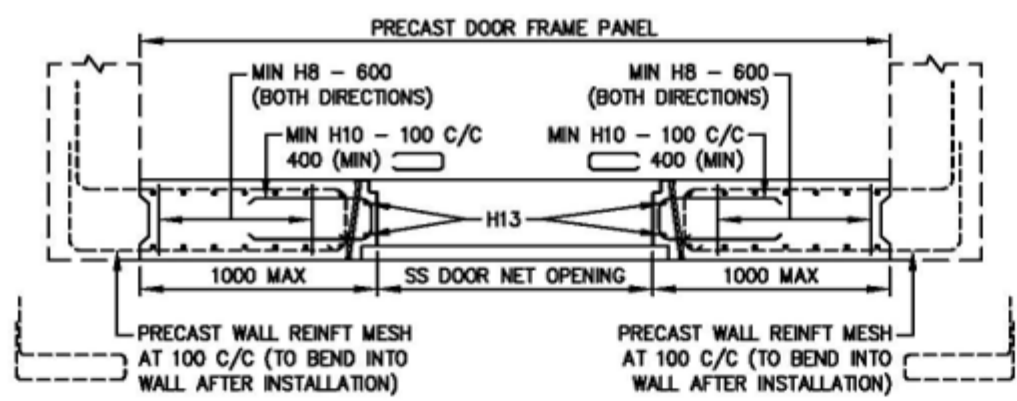
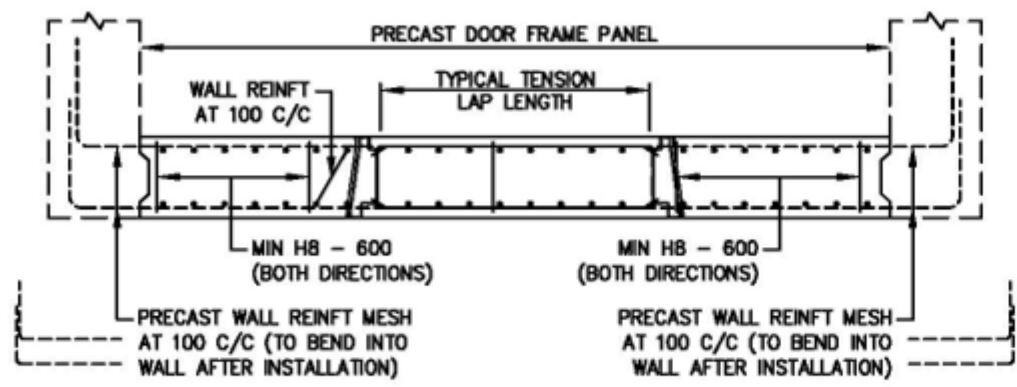

FIGURE 3.5.5(m): SECTIONS OF PRECAST SS DOOR FRAME PANEL (TYPE 3)



SECTION A - A



SECTION B - B

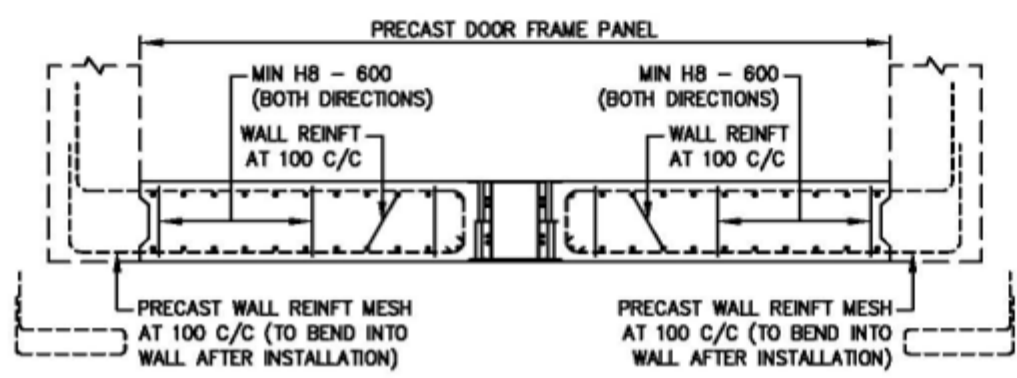

SECTION C - C

NOTE:

1. WALL REINFORCEMENT REFER TO TABLE 3.4.2.1
2. WALL REINFORCEMENTS AT VENTILATION SLEEVE LOCATION REFER TO FIGURE 3.5.5(o)(i) & (ii)

FIGURE 3.5.5(m): SECTIONS OF PRECAST SS DOOR FRAME PANEL (TYPE 3)

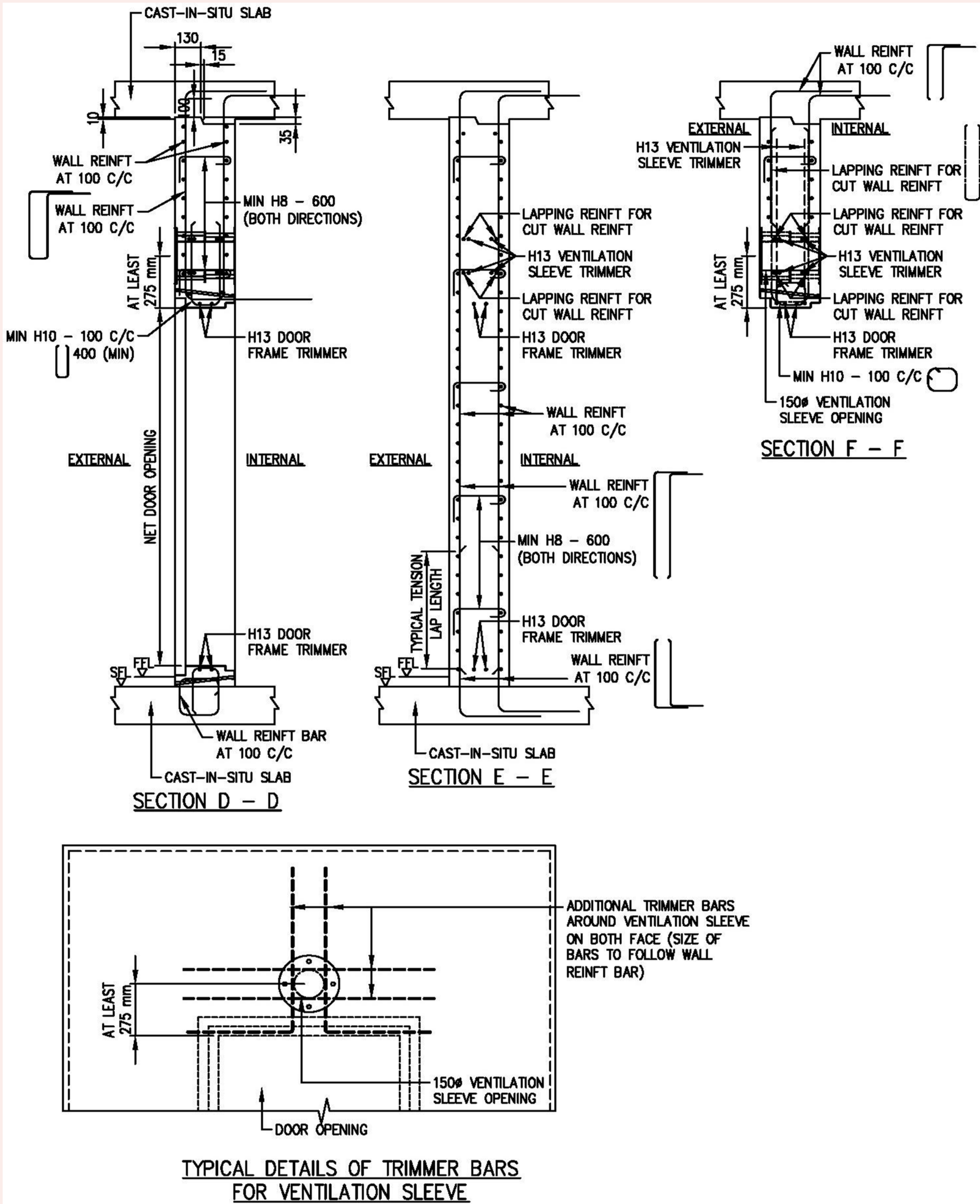

FIGURE 3.5.5(o)(i): TYPICAL DETAILS AND SECTIONS OF REINFORCEMENTS AT VENTILATION SLEEVE LOCATION

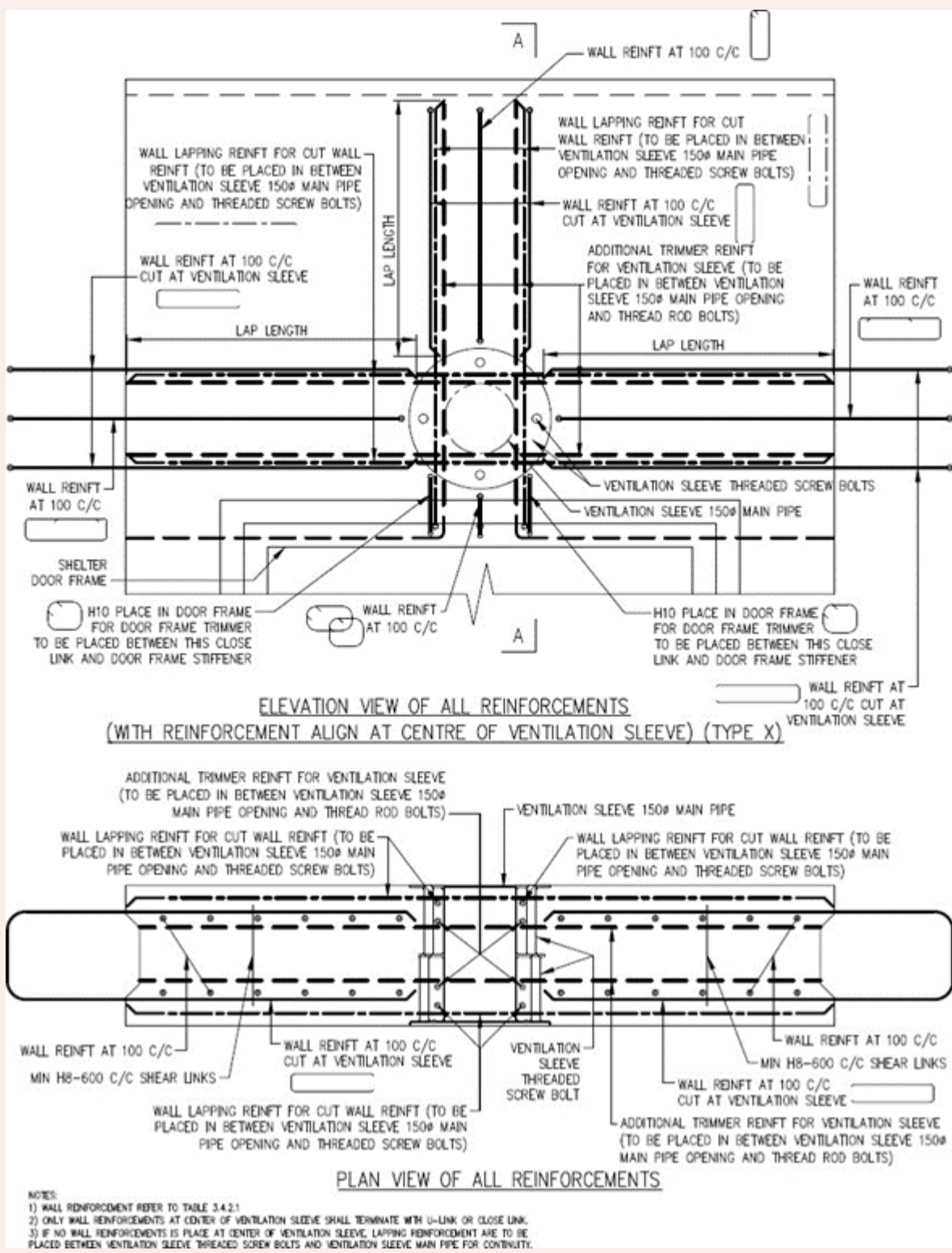

FIGURE 3.5.5(o)(ii): TYPICAL DETAILS AND SECTIONS OF REINFORCEMENTS AT VENTILATION SLEEVE LOCATION

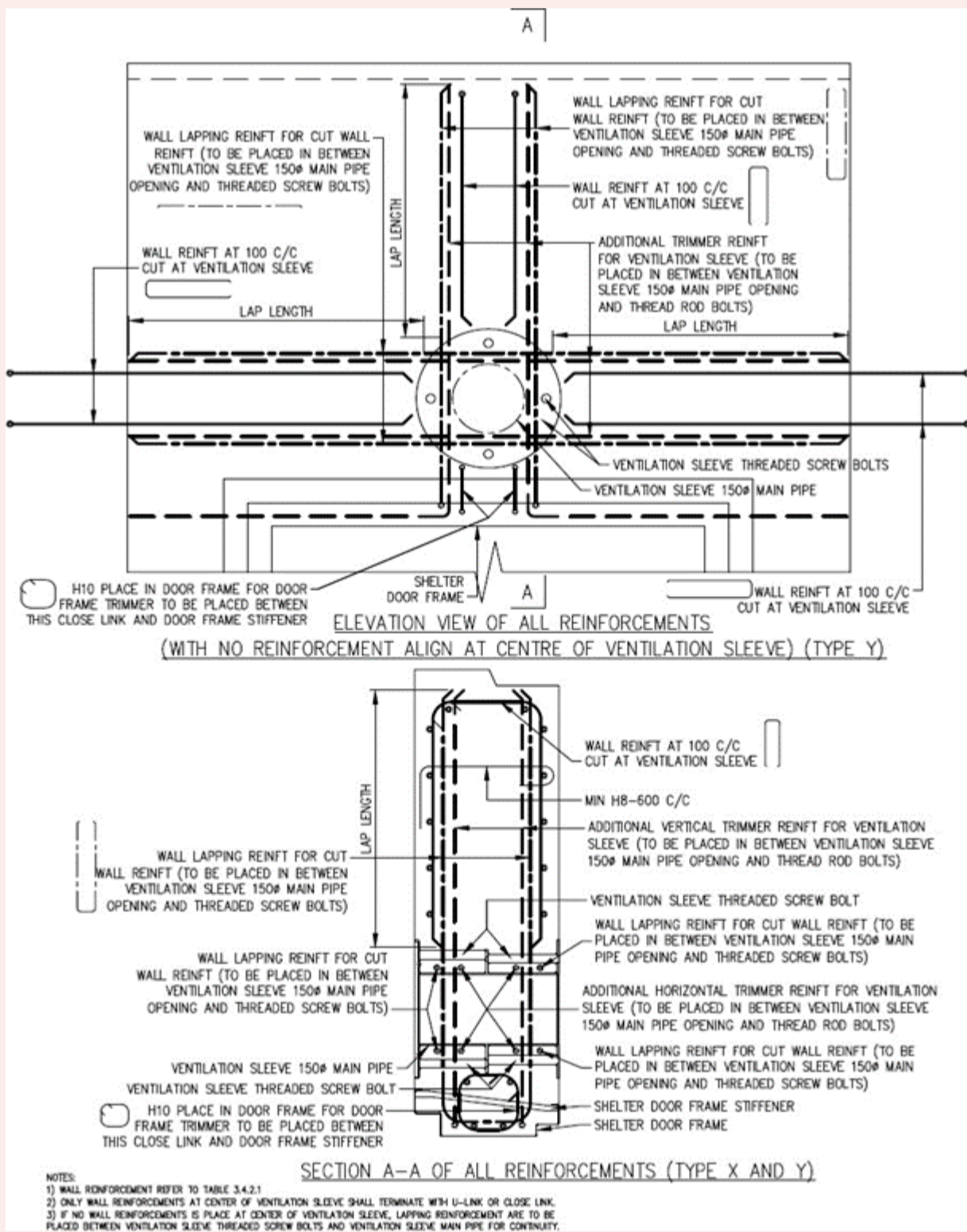
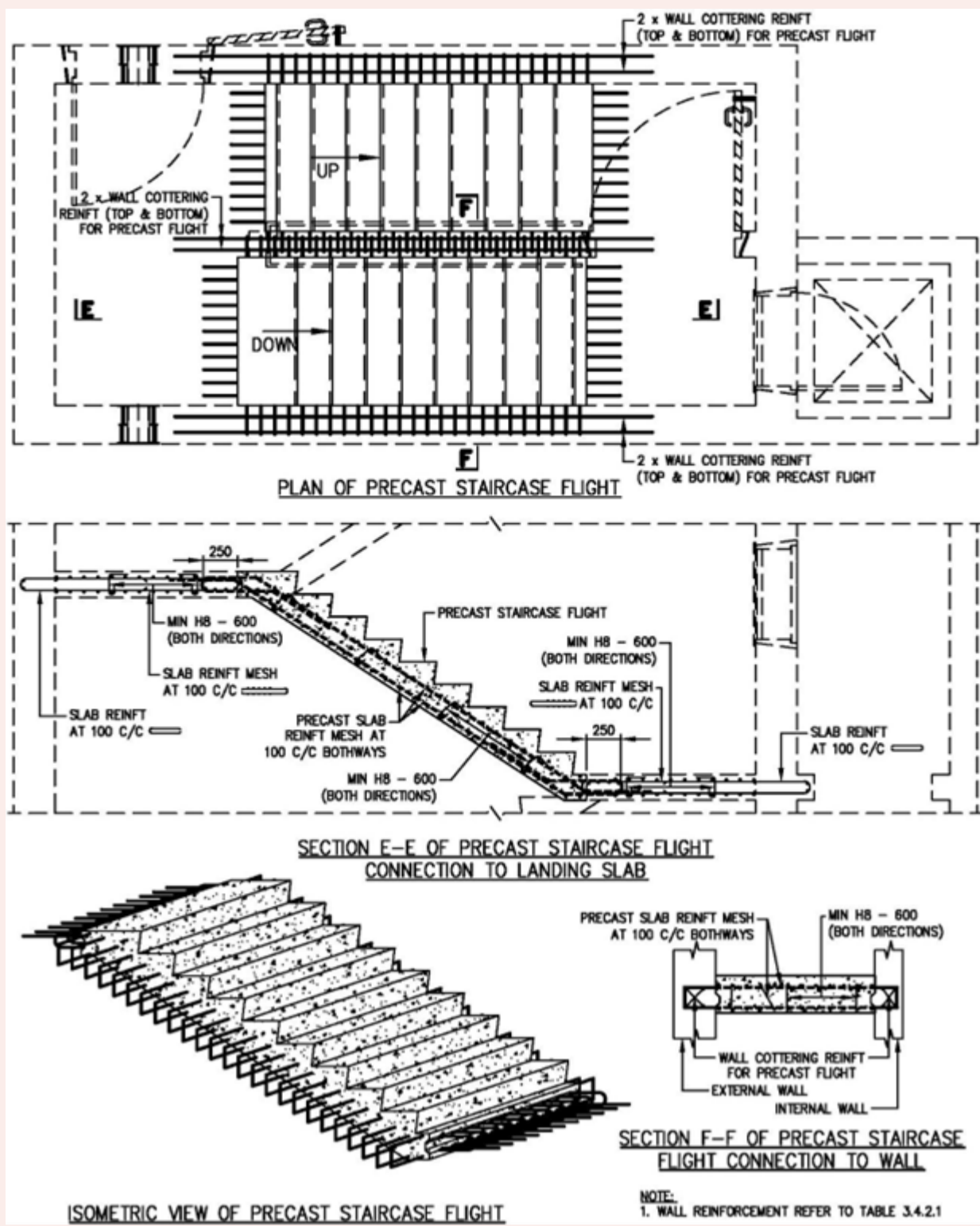

FIGURE 3.5.5(p): PLANS AND DETAILS OF SS SLABS FOR S/C SS PRECAST FLIGHT



3.5.5 Precast Elements for SS and S/C SS

FIGURE 3.5.5(a)	Plan of SS walls with precast SS door frame panel (Type 1)
FIGURE 3.5.5(b)	Details and sections of precast SS door frame panel with ventilation sleeve above it (Type 1)
FIGURE 3.5.5(c)	Sections of precast SS door frame panel with ventilation sleeve above it (Type 1)
FIGURE 3.5.5(d)	Details and sections of precast SS door frame panel with ventilation sleeve along its side (Type 1)
FIGURE 3.5.5(e)	Details and sections of precast SS door frame panel with ventilation sleeve along its side (Type 1)
FIGURE 3.5.5(f)	Plan of SS walls with precast SS door frame panel ((Type 2)
FIGURE 3.5.5(g)	Details and sections of precast SS door frame panel with ventilation sleeve above it (Type 2)
FIGURE 3.5.5(h)	Sections of precast SS door frame panel with ventilation sleeve above it (Type 2)
FIGURE 3.5.5(i)	Details and sections of precast SS door frame panel with ventilation sleeve along its side (Type 2)
FIGURE 3.5.5(j)	Sections of precast SS door frame panel with ventilation sleeve along its side (Type 2)
FIGURE 3.5.5(k)	Plan of SS walls with precast SS door frame panel (Type 3)
FIGURE 3.5.5(l)	Details of precast SS door frame panel (Type 3)
FIGURE 3.5.5(m)	Sections of precast SS door frame panel (Type 3)
FIGURE 3.5.5(n)	Sections of precast SS door frame panel (Type 3)
FIGURE 3.5.5(o)(i)	Typical details and sections of reinforcement at ventilation sleeve location
FIGURE 3.5.5(o)(ii)	Typical details and sections of reinforcement at ventilation sleeve location
FIGURE 3.5.5(p)	Plans and details of SS slabs for S/C SS precast flight

3.5.6 Precast Hollow Core S/C SS

3.5.6.1 Dimensions of Precast Hollow Core S/C SS

a. Precast hollow core staircase storey shelter shall be designed to meet the shelter area and volume requirements. The internal length and width of the precast S/C SS walls shall be modular with an increment of 100mm or 50mm respectively. Precast S/C SS comprises 3 parts as shown in FIGURE 3.5.6.1(a) and 3.5.6.1(b). Precast S/C SS, including the dimensions and spacing of modular hollow cores [See TABLE A & TABLE B of FIGURE 3.5.6.1(a)], ventilation sleeves, blast door, blast hatch and electrical fixtures are shown in FIGURE 3.5.6.1(a) to 3.5.6.1(c).

Figures & Tables

FIGURE 3.5.6.1(a) to 3.5.6.1(c)

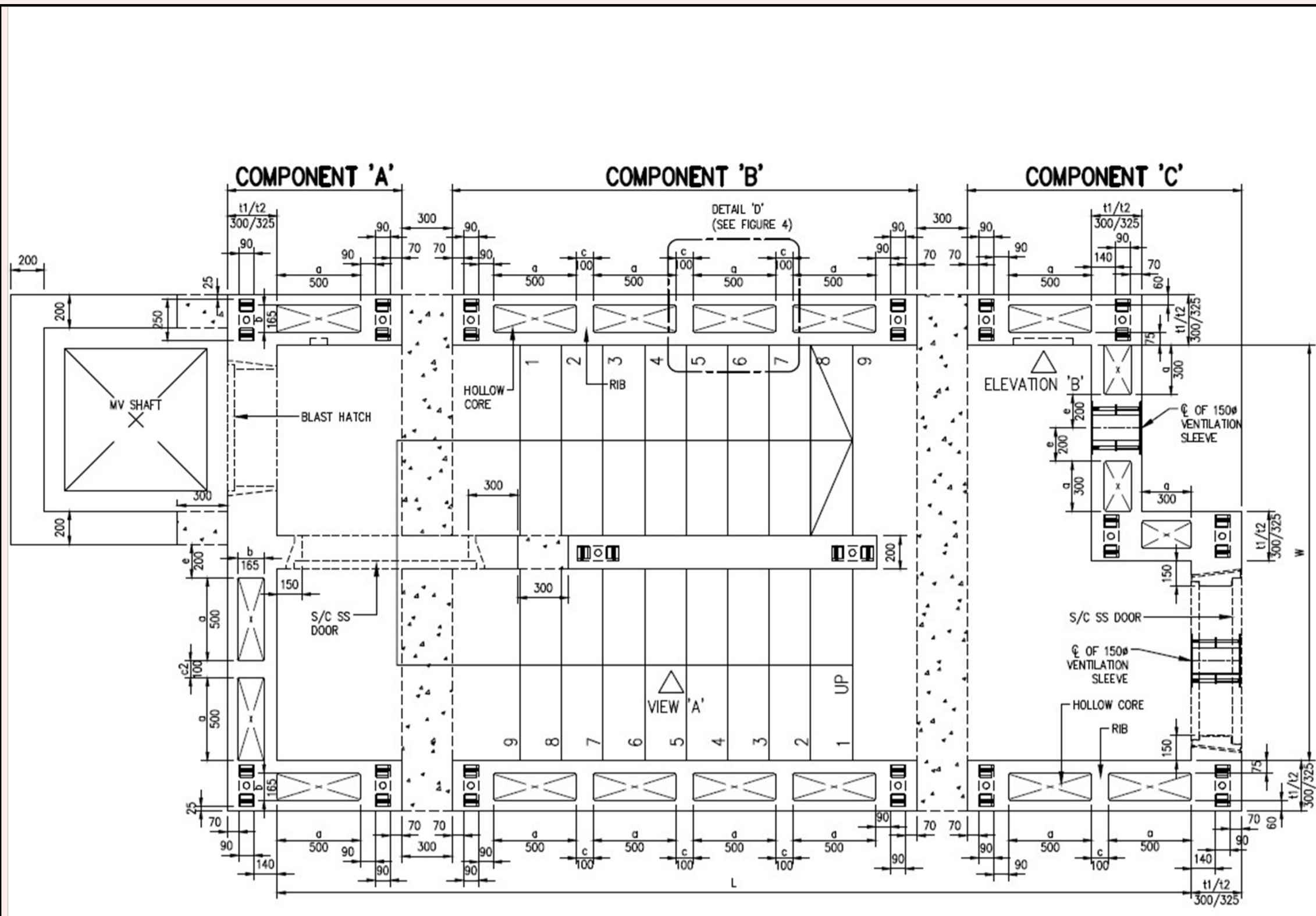

FIGURE 3.5.6.1(a): PLAN OF 3 VOLUMETRIC COMPONENTS OF PRECAST S/C SS
 (S/C SS DENOTES STAIRCASE STOREY SHELTER)

DIMENSIONS OF HOLLOW CORES & RIBS

TABLE A

SYMBOLS	DIMENSIONS	
	MIN. (MM)	MAX. (MM)
a*	200	500
e**	150	200

* DIMENSIONS WITH INCREMENT OF 100MM
 ** DIMENSIONS WITH INCREMENT OF 25MM

TABLE B

SYMBOLS	FIXED DIMENSIONS (MM)
b	165 for 300MM THICK S/C SS WALL OR 190 for 325MM THICK S/C SS WALL
c	100
t1	300
t2	325

NOTES:

1. THE INTERNAL LENGTH (L) AND WIDTH (W) OF THE S/C SS WALLS SHALL BE MODULAR IN SIZE WITH AN INCREMENT OF 50MM.
2. FOR ILLUSTRATION, MODULAR SIZE AND ARRANGEMENT OF HOLLOW CORES SHOWN ARE INDICATIVE ONLY.
3. SHELTER BUILDING PLAN SHALL INDICATE PRECAST S/C SS LAYOUT SHOWING ARRANGEMENT OF HOLLOW CORES WITH DIMENSION AND SPACING.
4. HOLLOW CORES SHALL BE MODULAR IN SIZE WITH INCREMENT OF 100MM FOR LENGTH (a).
5. HOLLOW CORES SHALL BE 500MM LONG WHERE POSSIBLE TO ACHIEVE A LIGHTER PRECAST S/C SS FOR EASE OF HANDLING AND MAXIMUM VERTICAL CONTINUITY.
6. OTHER SIZES OF HOLLOW CORE CAN BE USED TO FILL UP THE WALL AREA WHERE 500MM LONG HOLLOW CORE CANNOT BE FORMED.
7. FOR BEAM WITH MORE THAN ONE SUPPORTS, ONE END OF THE BEAM THAT IS SUPPORTED ON THE PRECAST S/C SS WALL SHALL BE DESIGNED AND DETAILED AS SIMPLY SUPPORTED.

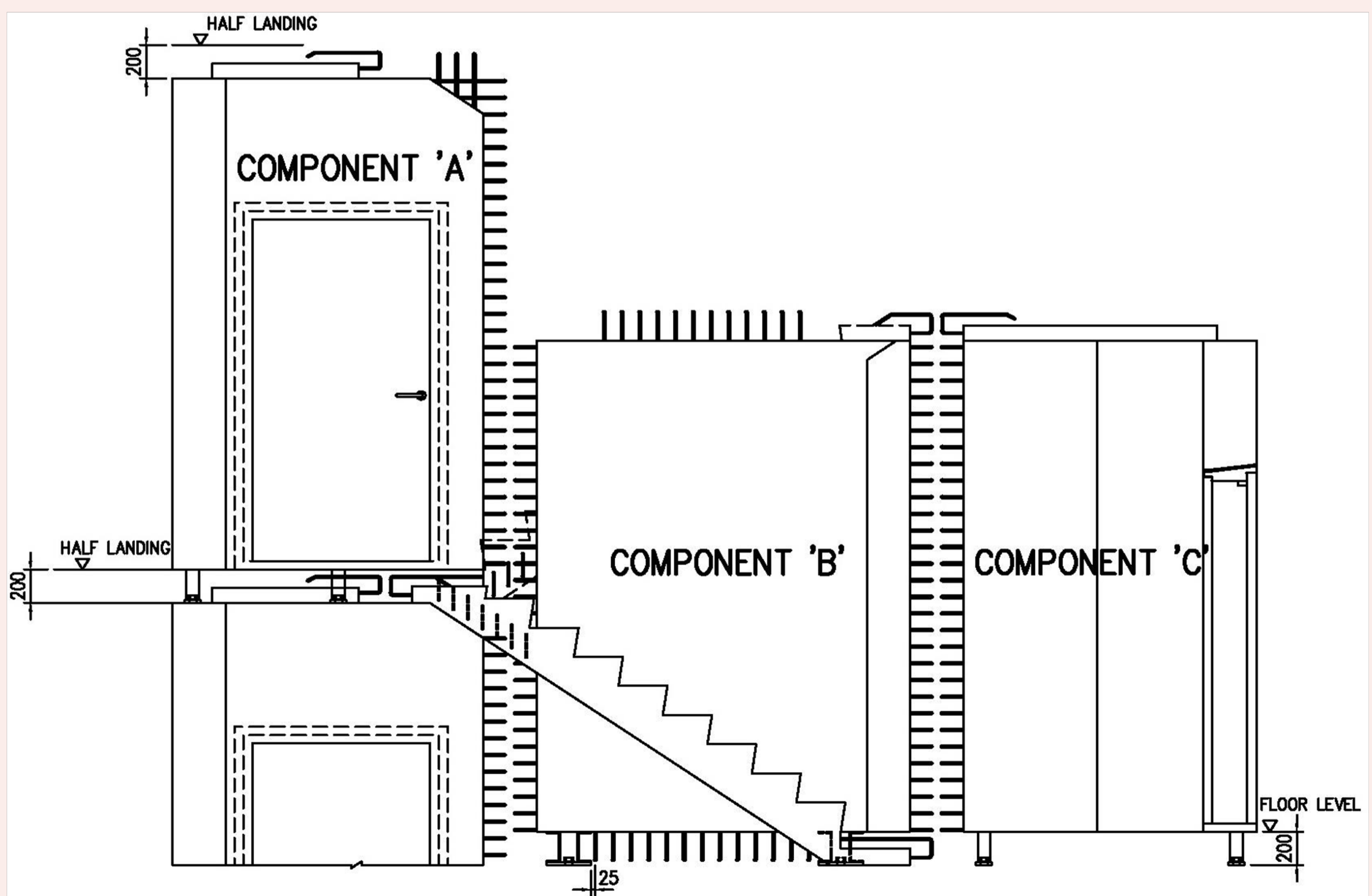

FIGURE 3.5.6.1(b): INTERNAL ELEVATION VIEW 'A' OF 3 VOLUMETRIC COMPONENTS OF PRECAST S/C SS

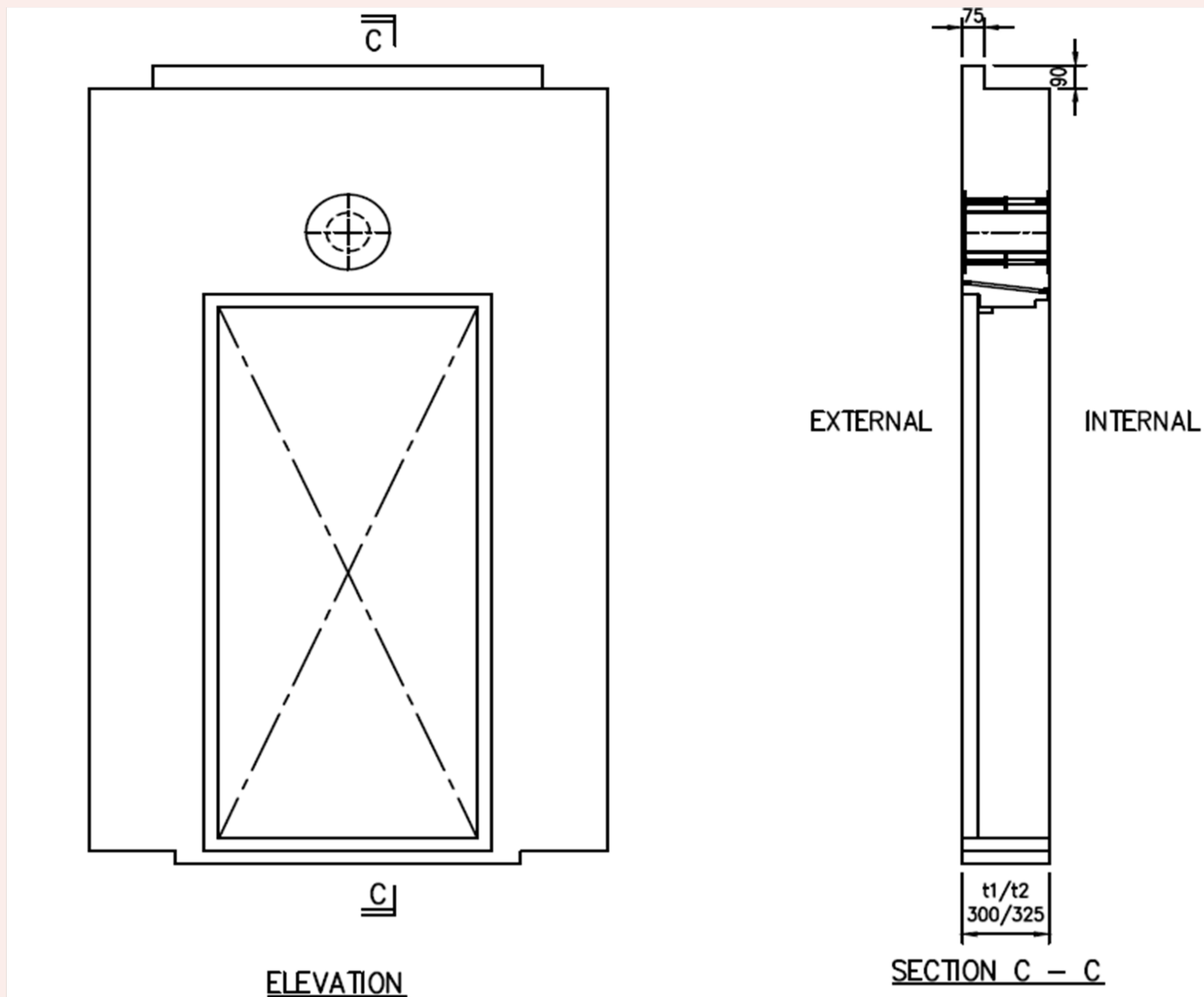

FIGURE 3.5.6.1(c): BLAST DOOR AND VENTILATION SLEEVE

i. FIGURE 3.5.6.1(a): Plan of 3 Volumetric Components of Precast S/CSS.

Figures & Tables

FIGURE 3.5.6.1(a): Plan of 3 Volumetric Components of Precast S/CSS.

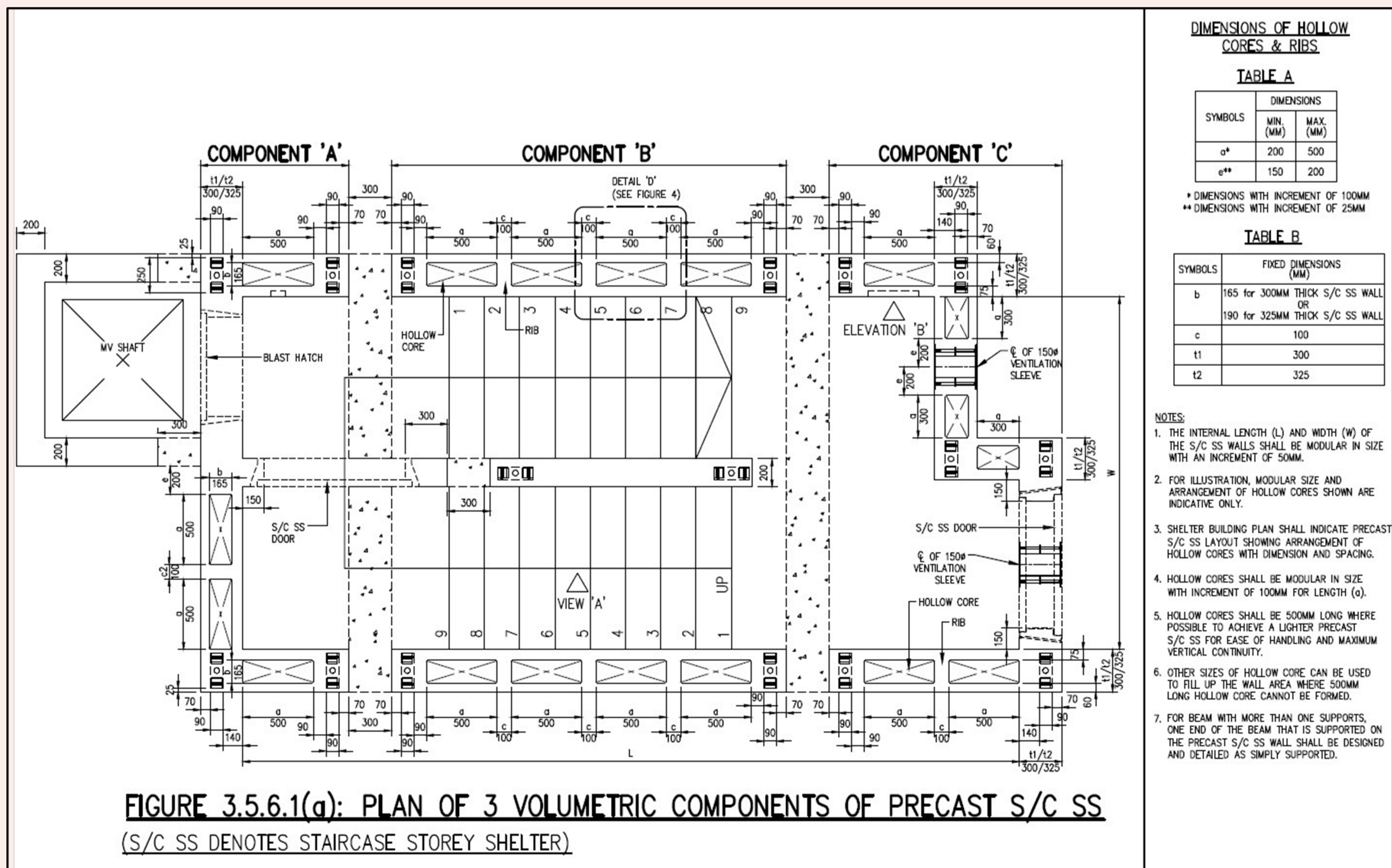
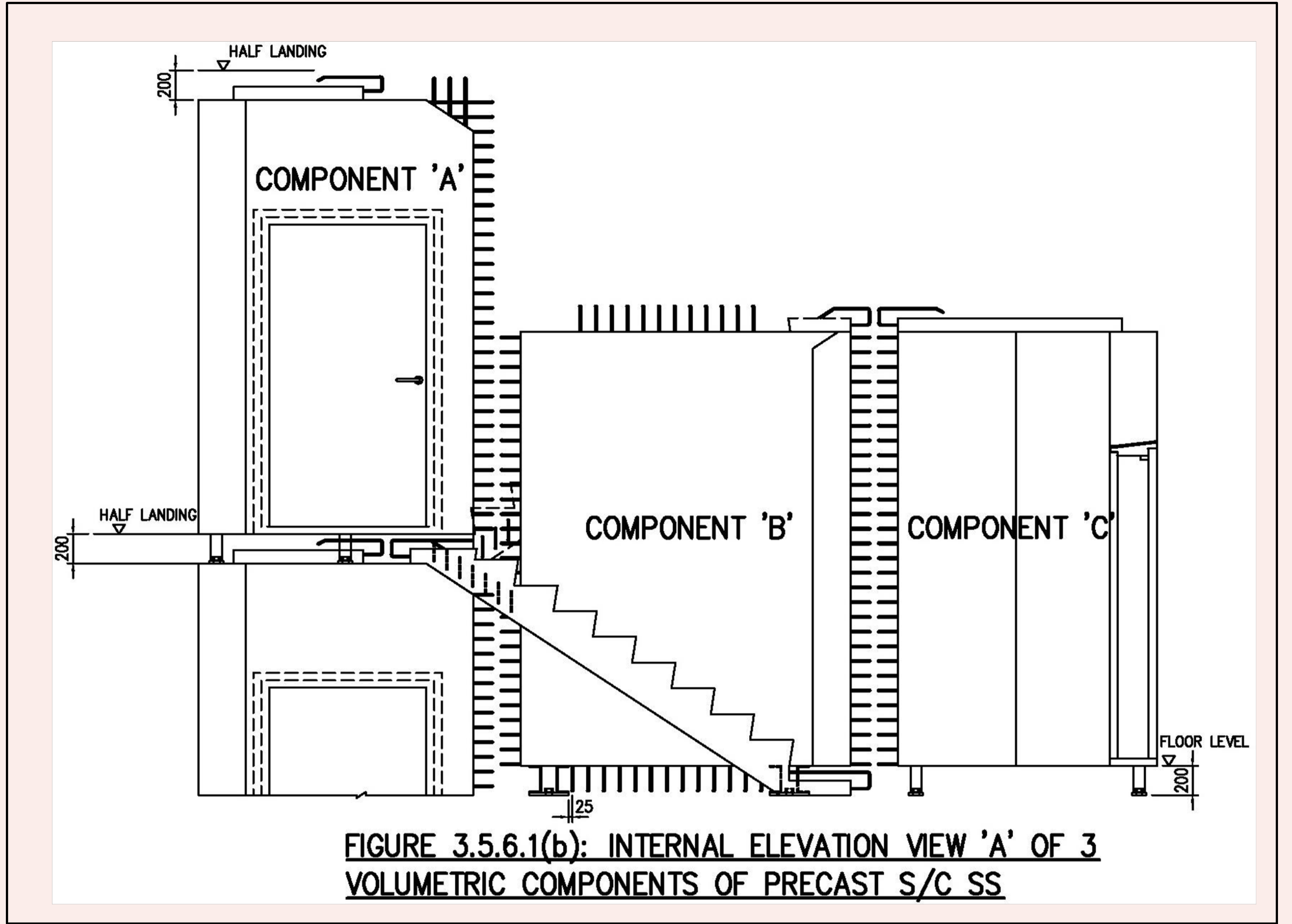

FIGURE 3.5.6.1(a): PLAN OF 3 VOLUMETRIC COMPONENTS OF PRECAST S/C SS
(S/C SS DENOTES STAIRCASE STOREY SHELTER)

Figures & Tables

FIGURE 3.5.6.1(b)



Figures & Tables

FIGURE 3.5.6.1(c)

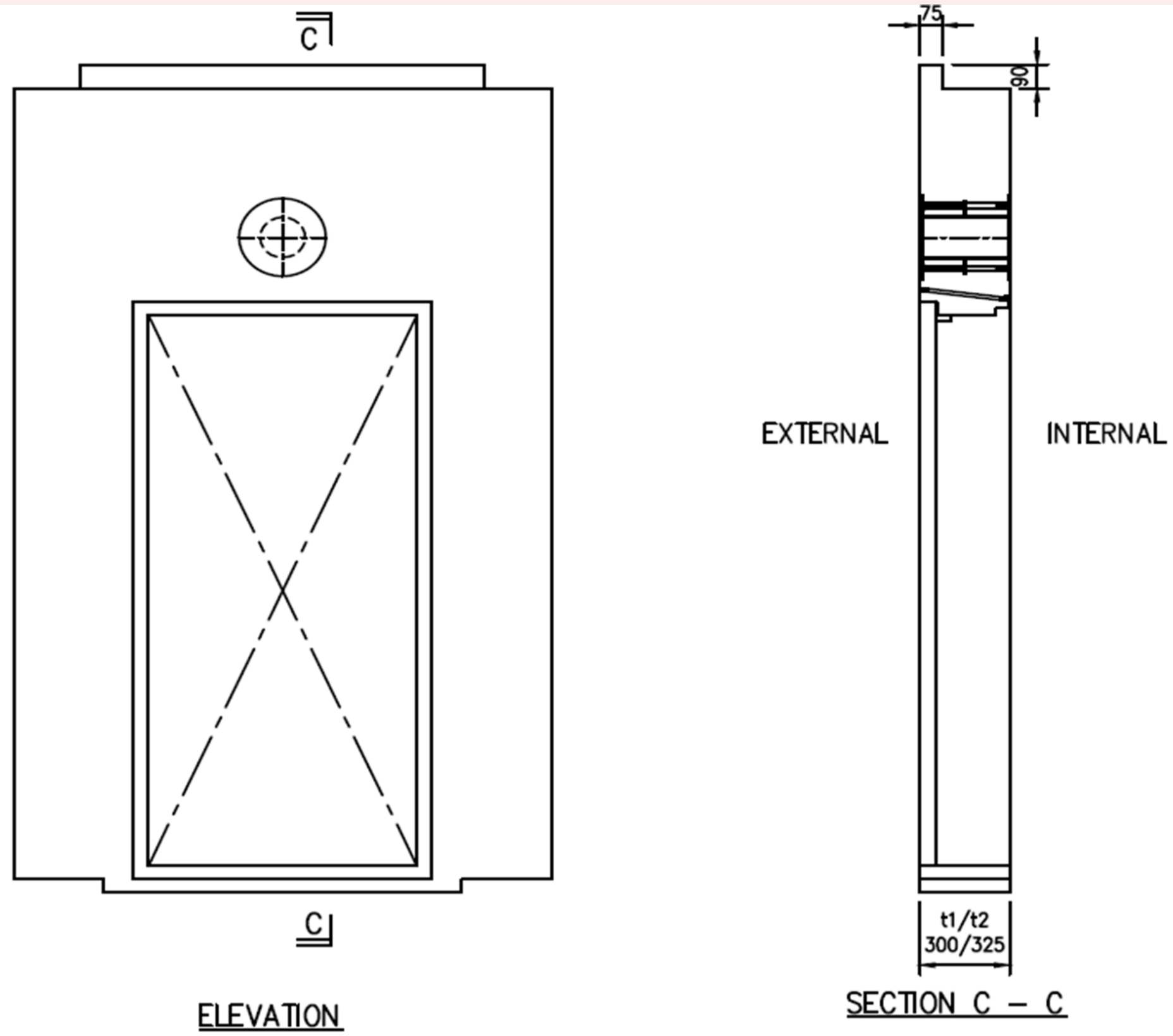

FIGURE 3.5.6.1(c): BLAST DOOR AND VENTILATION SLEEVE

b. To facilitate de-moulding of the precast S/C SS, the hollow cores shall be tapered all round along its height as shown in FIGURE 3.5.6.1(d).

Figures & Tables

FIGURE 3.5.6.1(d)

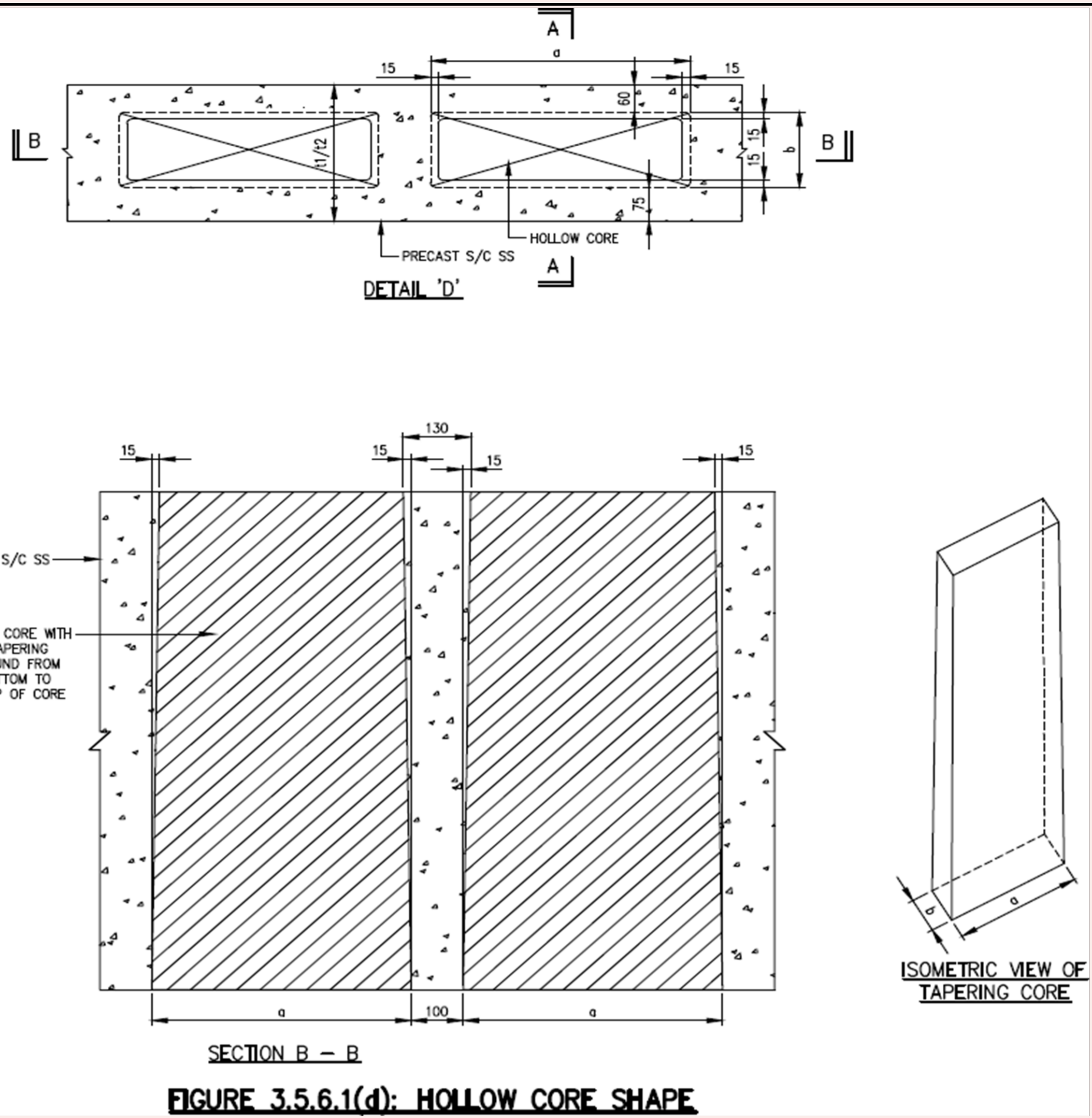

FIGURE 3.5.6.1(d): HOLLOW CORE SHAPE

i. FIGURE 3.5.6.1(d): Hollow Core Shape.

Figures & Tables

FIGURE 3.5.6.1(d)

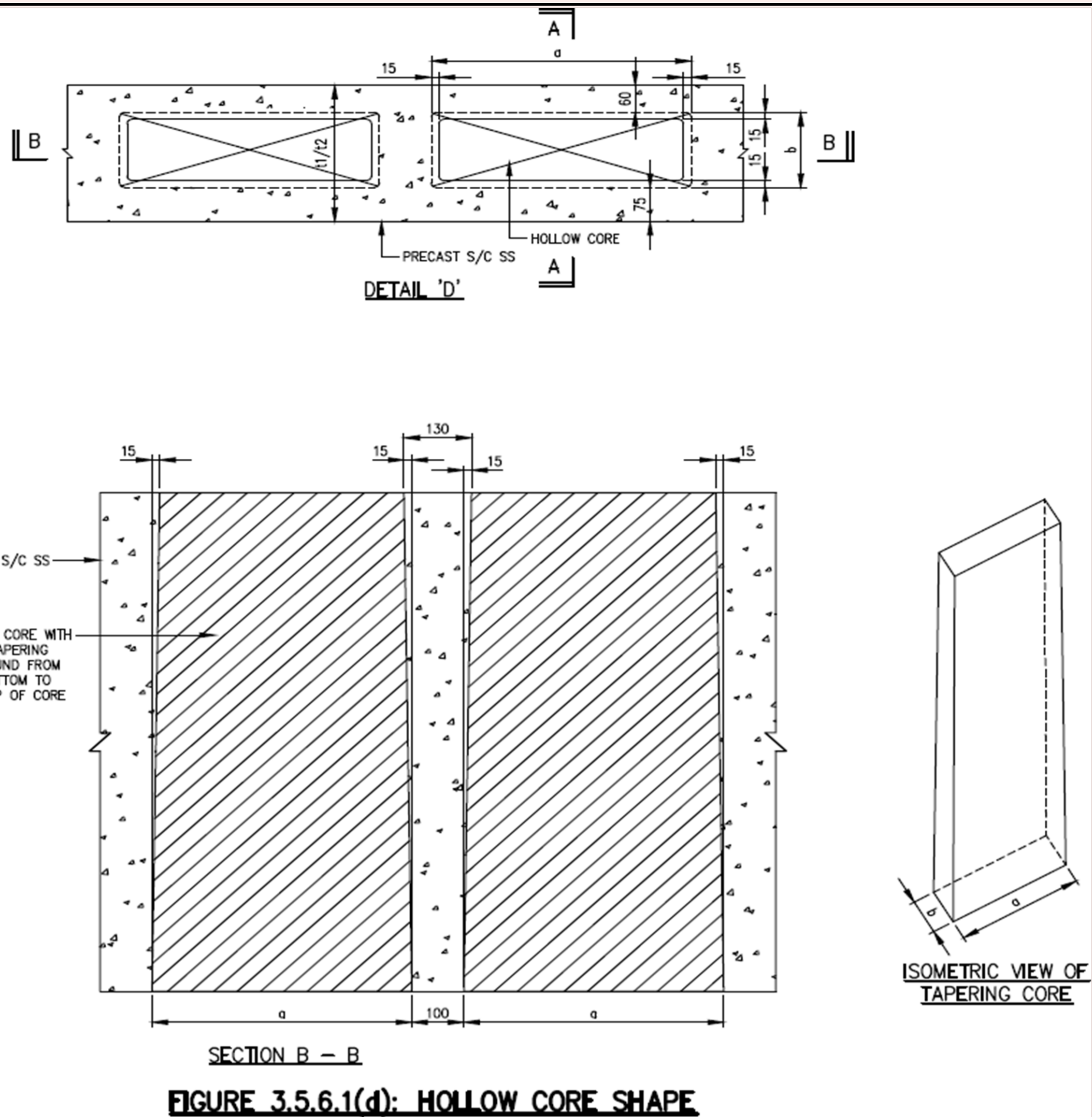

FIGURE 3.5.6.1(d): HOLLOW CORE SHAPE

c. Where possible, hollow core of maximum 500mm long shall be adopted to achieve lighter precast SSS components for ease of handling and achievement of maximum vertical continuity.

3.5.6.2 Reinforcement Requirements

- a. The reinforcements of precast S/C SS shall be welded steel fabric mesh and hot rolled steel bars. Reinforcements specified for precast slab components, walls and hollow cores of the precast SSS refer to minimum bar diameters and maximum spacing in both directions.
- b. In the precast S/C SS walls, reinforcements shall be welded steel fabric mesh of minimum H13 at 100mm c/c spacing or minimum H16 at 100mm c/c spacing depending on the clear height of staircase storey shelter as specified in [Clause 3.4.2.1](#) and TABLE 3.4.2.1.

Figures & Tables

TABLE 3.4.2.1 : MINIMUM REINFORCEMENTS OF SS OR NS WALLS

SS/NS Clear Height (mm)	Reinforcement at both internal and external face of wall (both directions)	Shear Links (both directions)
2400 < Ht ≤ 3400	H13 - 100 c/c	H8 - 600 c/c
3400 < Ht ≤ 3900	H16 - 100 c/c	H8 600 c/c

c. The details of reinforcements for precast S/C SS, the rib of precast S/C SS, connection between precast S/C SS components, S/C SS door frame, blast hatch, electrical fixtures, trimmer bars around ventilation sleeve openings, at door recess and hollow cores are shown in FIGURE 3.5.6.2(a)(i) to 3.5.6.2(k):

Figures & Tables

FIGURE 3.5.6.2(a)(i) & FIGURE 3.5.6.2(a)(ii)

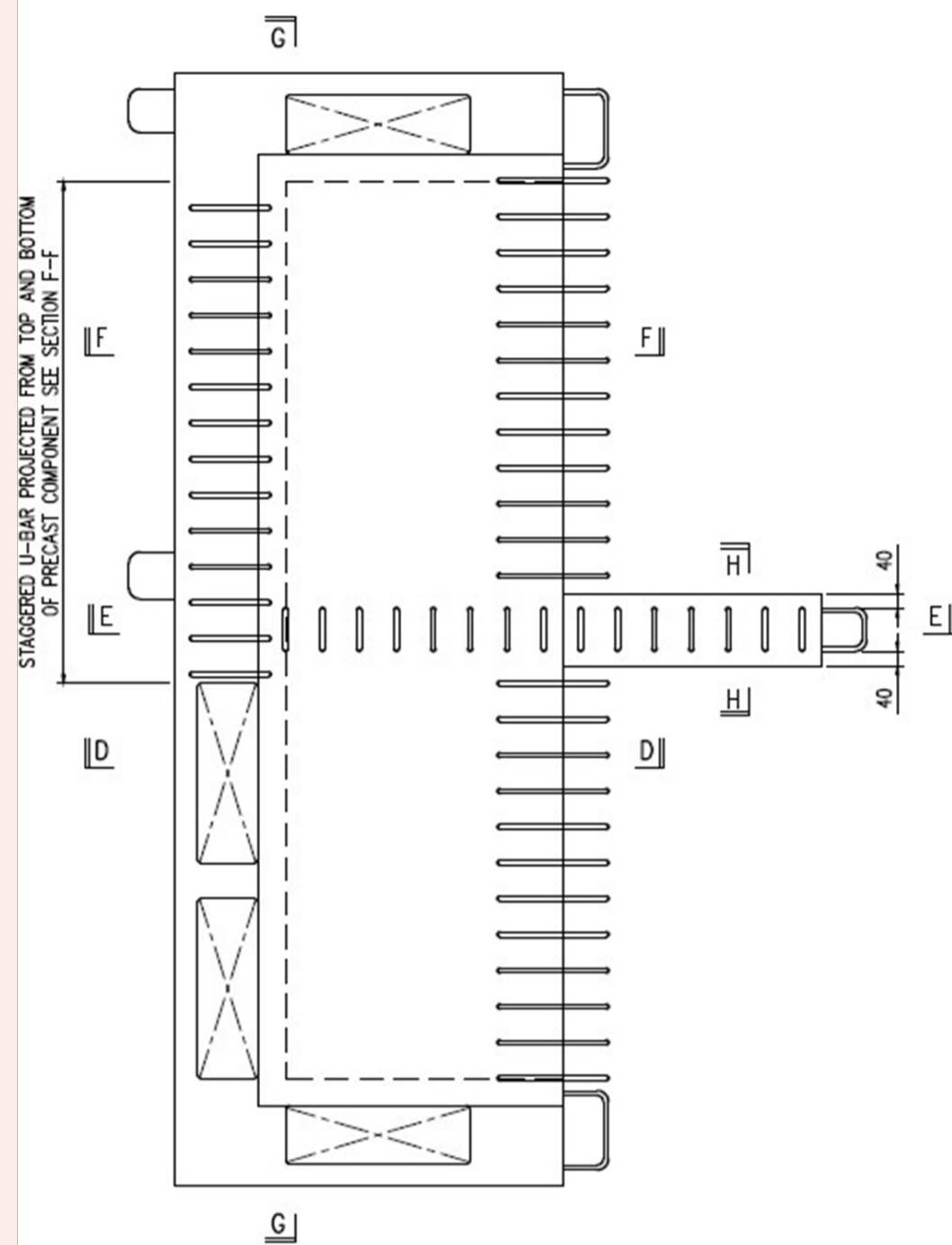

FIGURE 3.5.6.2(a)(i): PLAN OF PRECAST S/C SS (S/C SS COMPONENT 'A')

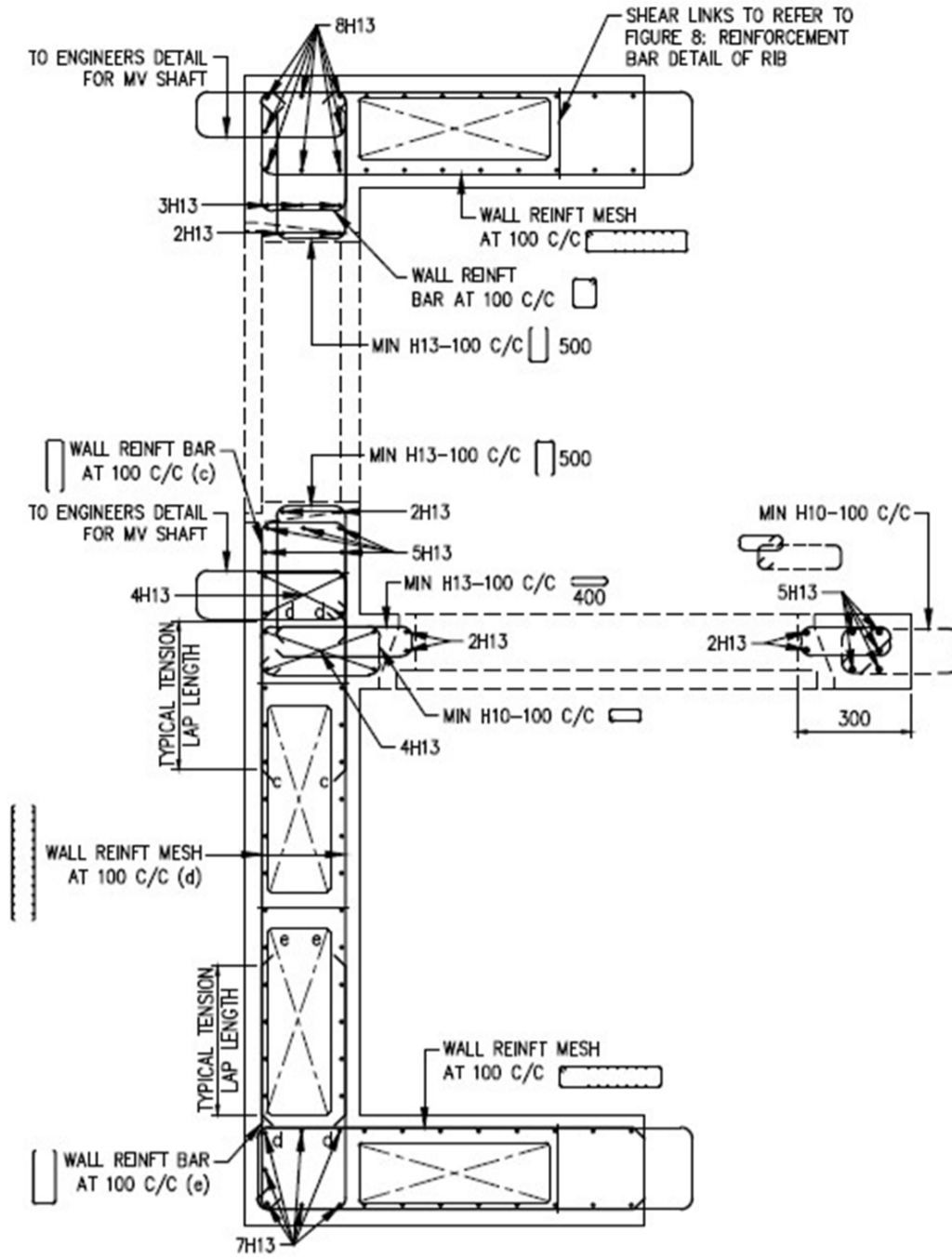

FIGURE 3.5.6.2(a)(ii): PLAN OF PRECAST S/C SS WALL WITH REINFORCEMENT DETAILS AT BLAST HATCH OPENING (S/C SS COMPONENT 'A')

- NOTES:**
1. MINIMUM 600MM LAPPED LENGTH FOR H16
MINIMUM 500MM LAPPED LENGTH FOR H13
MINIMUM 400MM LAPPED LENGTH FOR H10
- 
- MINIMUM HOOK AND BEND FOR SHEAR LINKS (H8)**
- 
- PLAN AND SECTION OF RIB WITH SHEAR LINKS**
2. MINIMUM BAR SIZE OF WELDED STEEL FABRIC MESH AND HOT-ROLLED STEEL BARS FOR STAIRCASE STOREY SHELTER WALL AND SLAB SHALL BE PROVIDED IN COMPLIANCE WITH TECHNICAL REQUIREMENT FOR STAIRCASE STOREY SHELTERS.
 3. MAXIMUM SPACING OF ALL REINFORCEMENT BARS FOR WALL OR SLAB SHALL BE 100MM IN BOTH DIRECTIONS.
 4. ALL REINFORCEMENT BARS FOR WALL AND SLAB SHALL BE WITH FULL TENSION LAP LENGTH.
 5. MINIMUM CONCRETE GRADE SHALL BE C32/40.
 6. MINIMUM YIELD STRESS FOR MAIN REINFORCEMENT BARS AND SHEAR LINKS FOR STRUCTURAL ELEMENTS OF STAIRCASE STOREY SHELTER SHALL BE 500 N/MM².
 7. MAXIMUM CONCRETE COVER SHALL BE 40MM.
 8. MINIMUM CONCRETE COVER TO REINFORCEMENT BARS OF STAIRCASE STOREY SHELTER WALL AND SLAB SHALL BE 25MM.
 9. MAXIMUM SPACING OF SHEAR LINK WITH HOOK AND BEND SHALL BE 600MM.
 10. THE HOOK OF SHEAR LINK SHALL BE PLACED AT THE INTERNAL FACE OF STAIRCASE STOREY SHELTER WALL (SEE NOTE 1) AND SLAB.
 11. THE HOOK AND BEND OF SHEAR LINK MUST BE ANCHORED OVER THE OUTER MOST REINFORCEMENT BARS OF STAIRCASE STOREY SHELTER WALL AND SLAB.
 12. 6H8 SHEAR LINK SPACED AT 100MM SHALL BE PROVIDED AT BOTTOM AND TOP PART OF THE RIB BETWEEN TWO HOLLOW CORES OF PRECAST STAIRCASE STOREY SHELTER (SEE FIGURE 8).
 13. THE LIFTING DEVICES FOR HANDLING PRECAST STAIRCASE STOREY SHELTERS SHALL BE DESIGNED WITH ADEQUATE SAFETY FACTORS BY PROFESSIONAL ENGINEERS.

FIGURE 3.5.6.2(a)(iii), FIGURE 3.5.6.2(a)(iv) && FIGURE 3.5.6.2(a)(v)

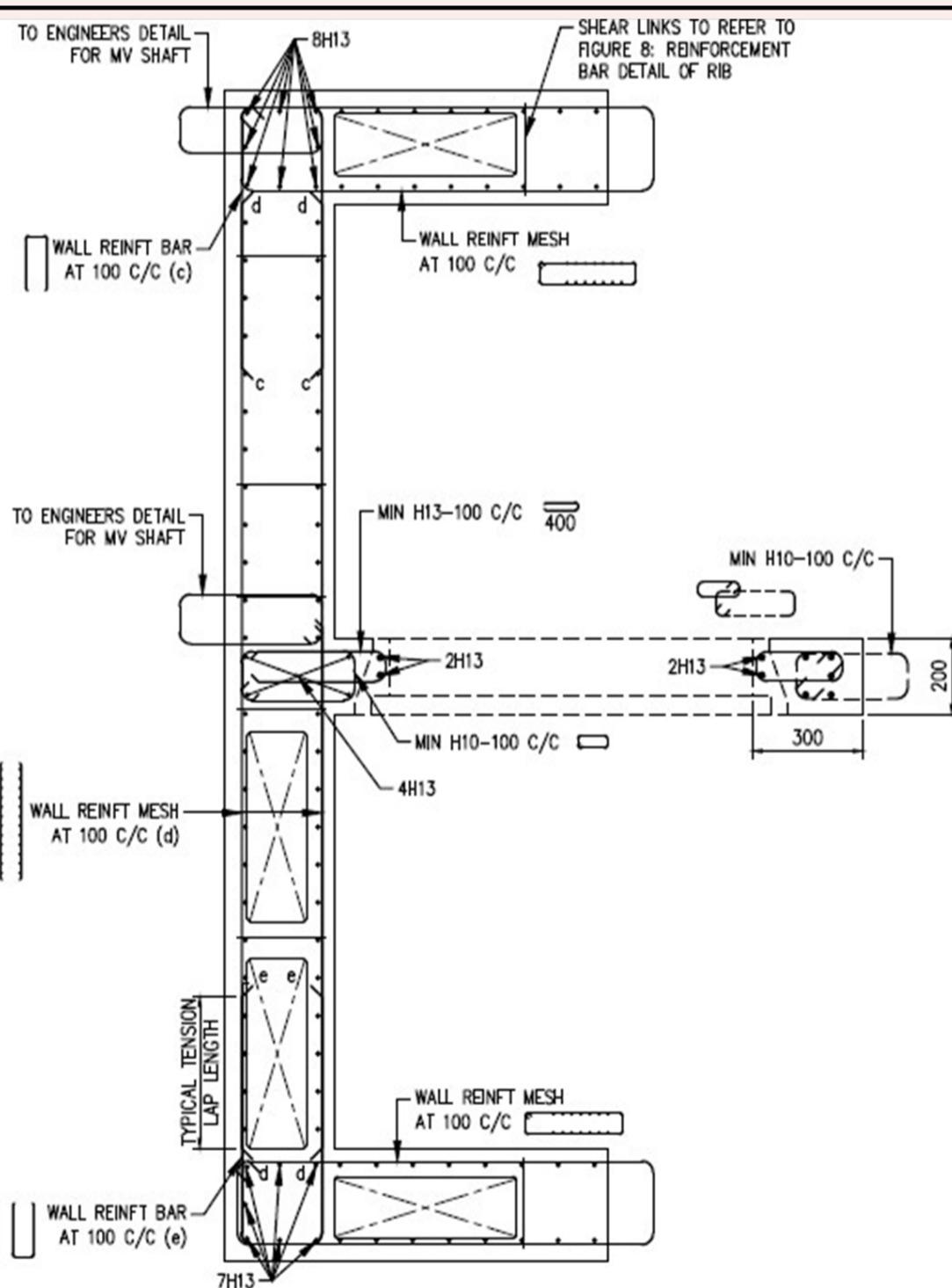

FIGURE 3.5.6.2(a)(iii): PLAN OF PRECAST S/C SS WALL WITH REINFORCEMENT DETAILS ABOVE BLAST HATCH OPENING (S/C SS COMPONENT 'A')

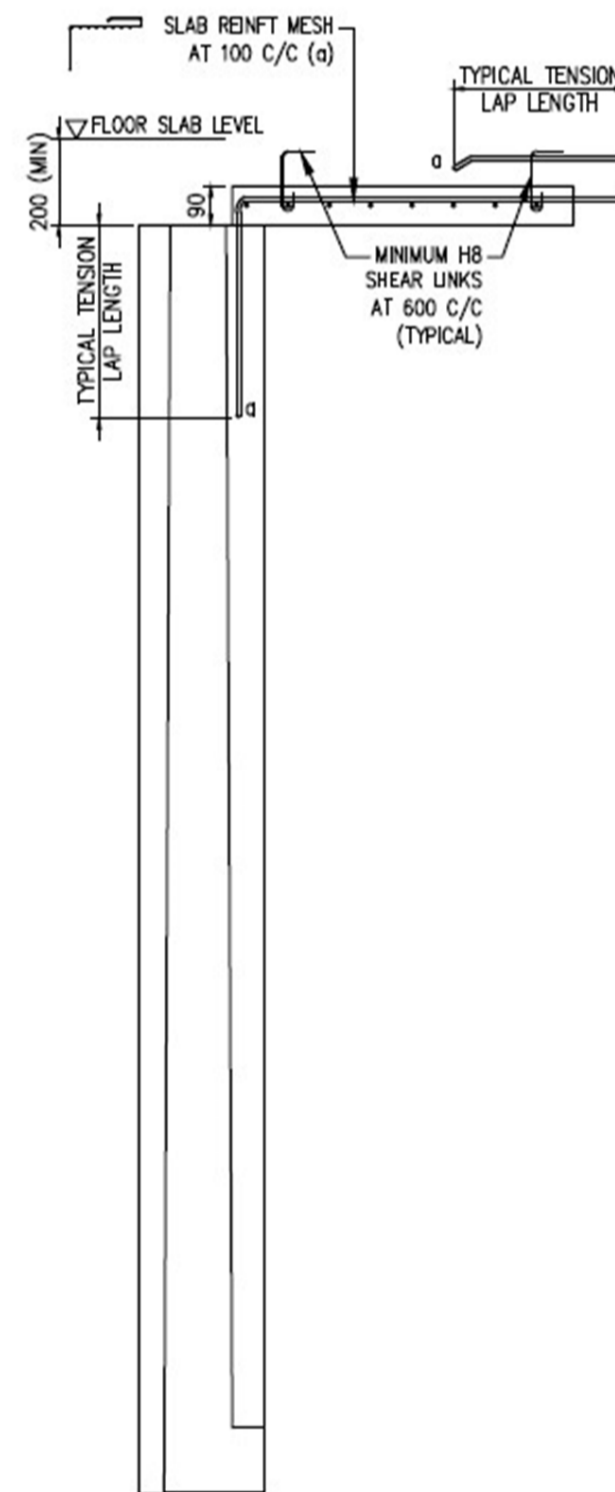

FIGURE 3.5.6.2(a)(iv): SECTION D-D (S/C SS COMPONENT 'A')

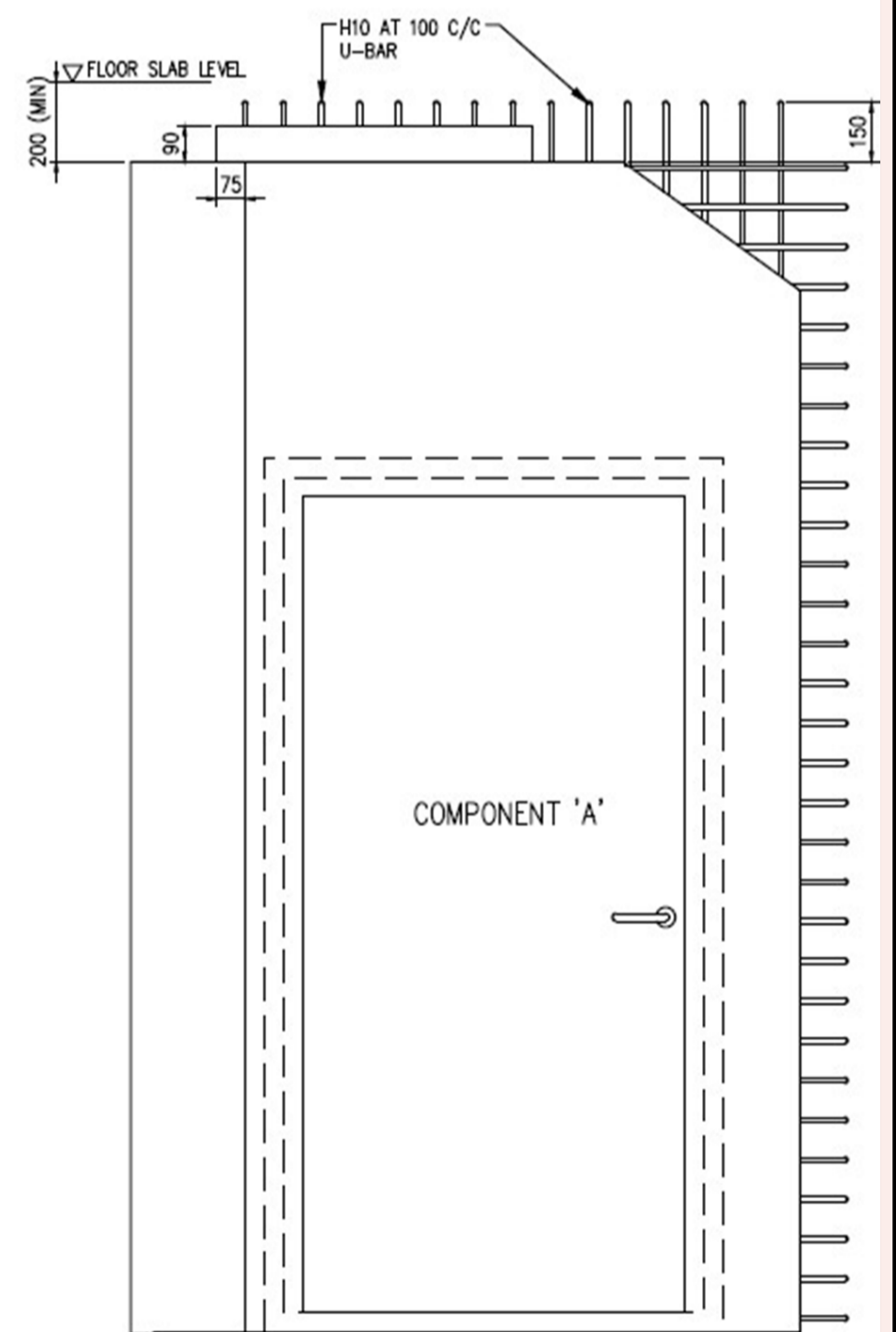

FIGURE 3.5.6.2(a)(v): SECTION E-E (S/C SS COMPONENT 'A')

FIGURE 3.5.6.2(a)(vi)

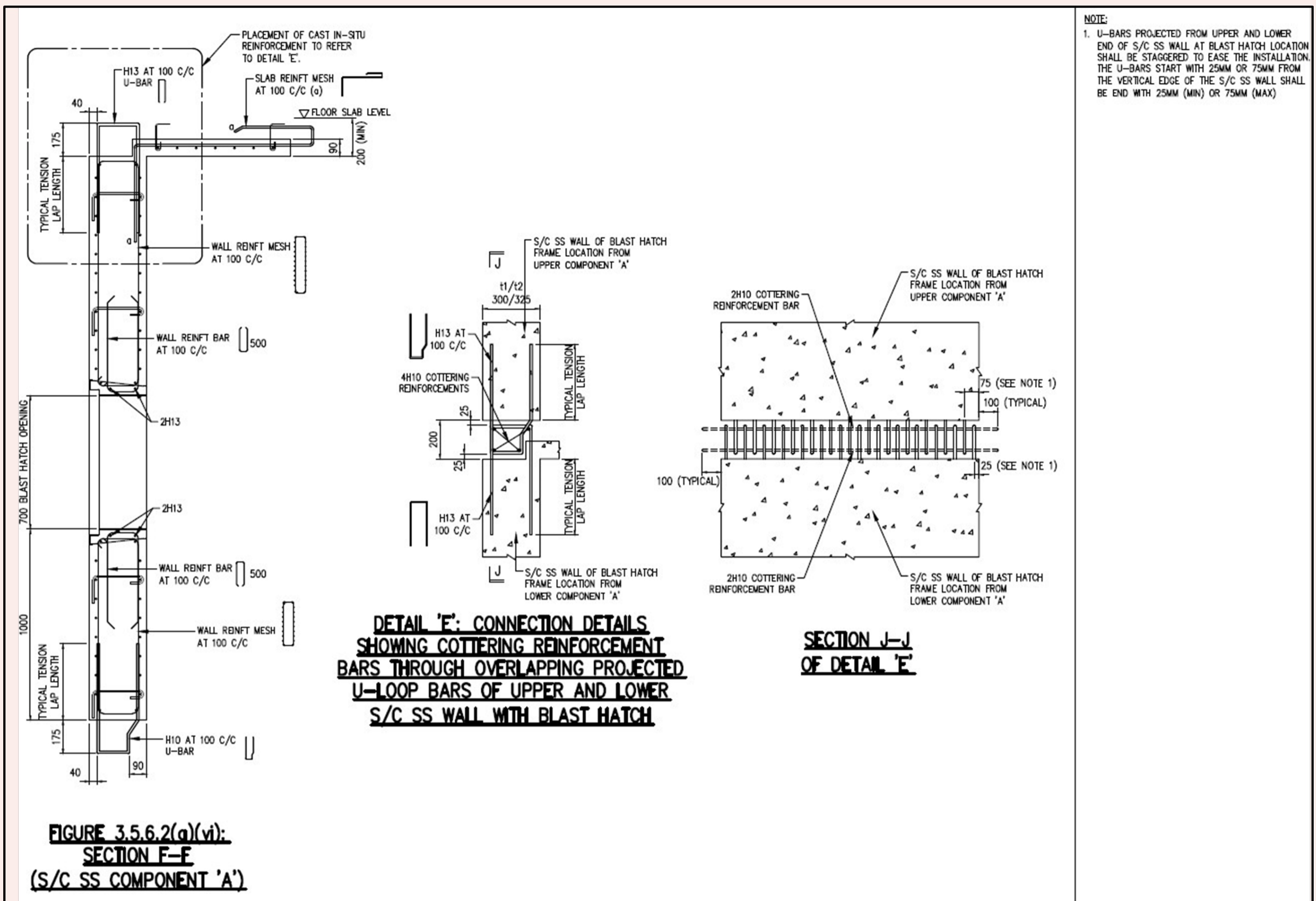

FIGURE 3.5.6.2(a)(vii) & FIGURE 3.5.6.2(a)(viii)

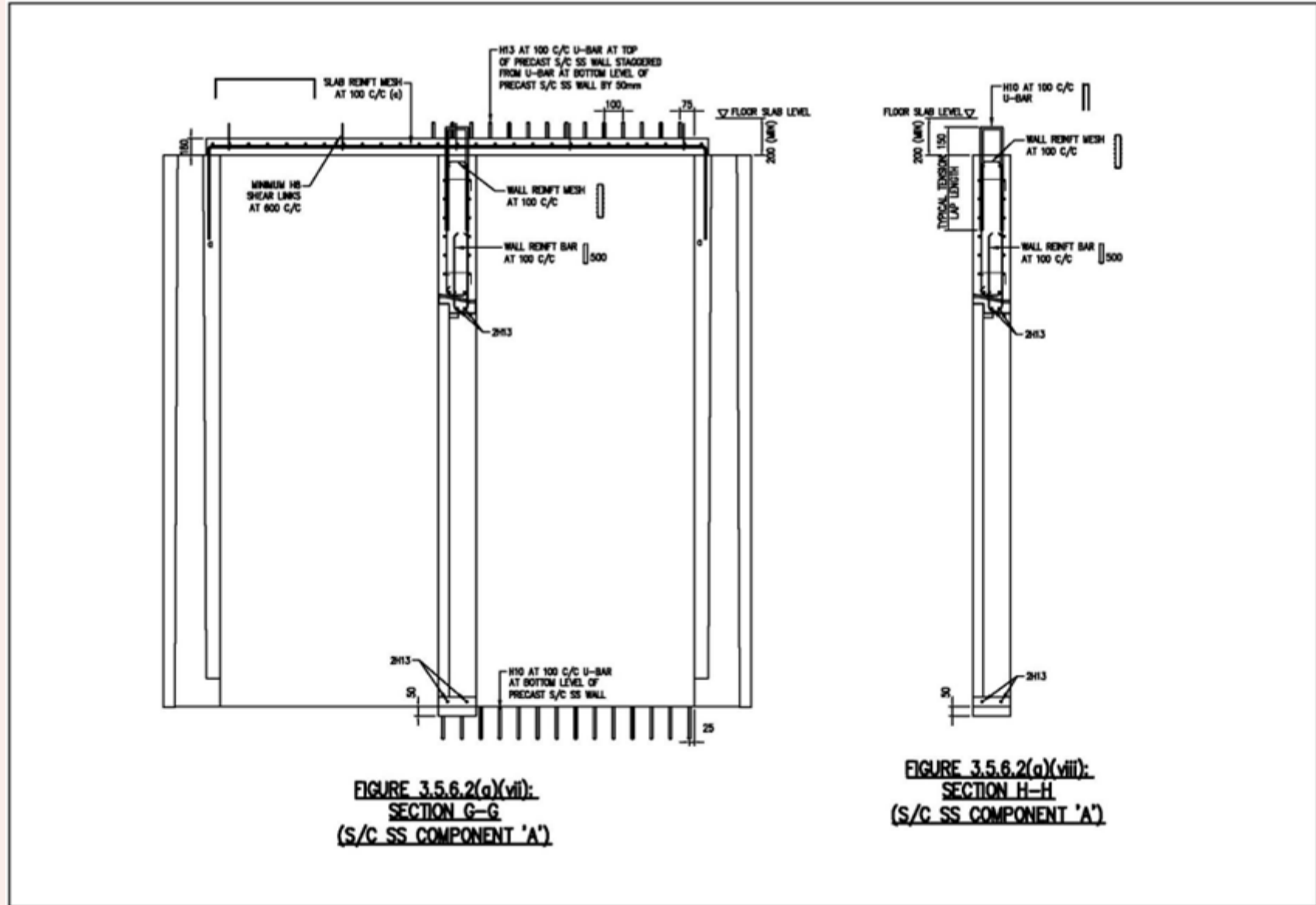

FIGURE 3.5.6.2(b)(i) & FIGURE 3.5.6.2(b)(ii)

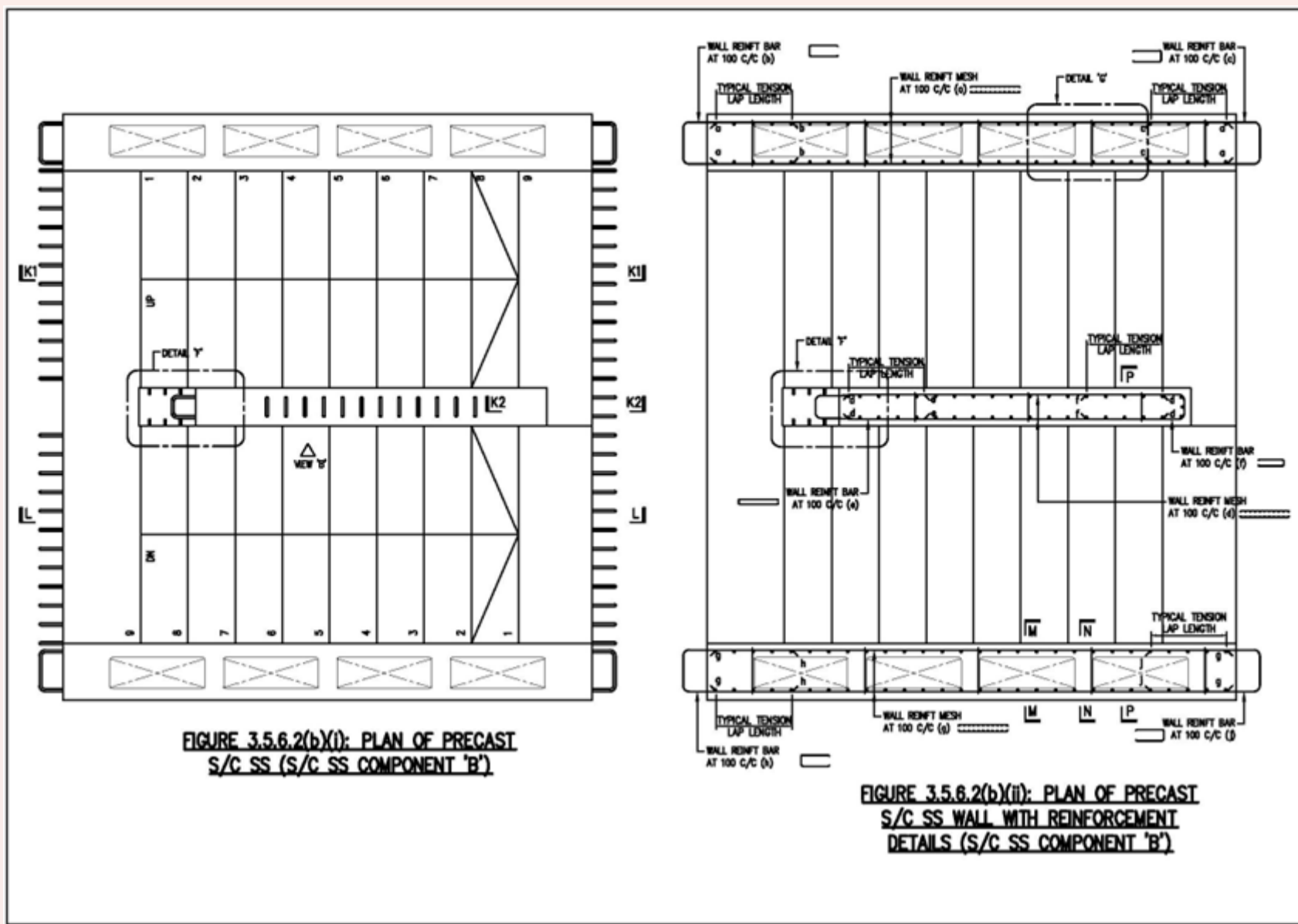

FIGURE 3.5.6.2(b)(iii)

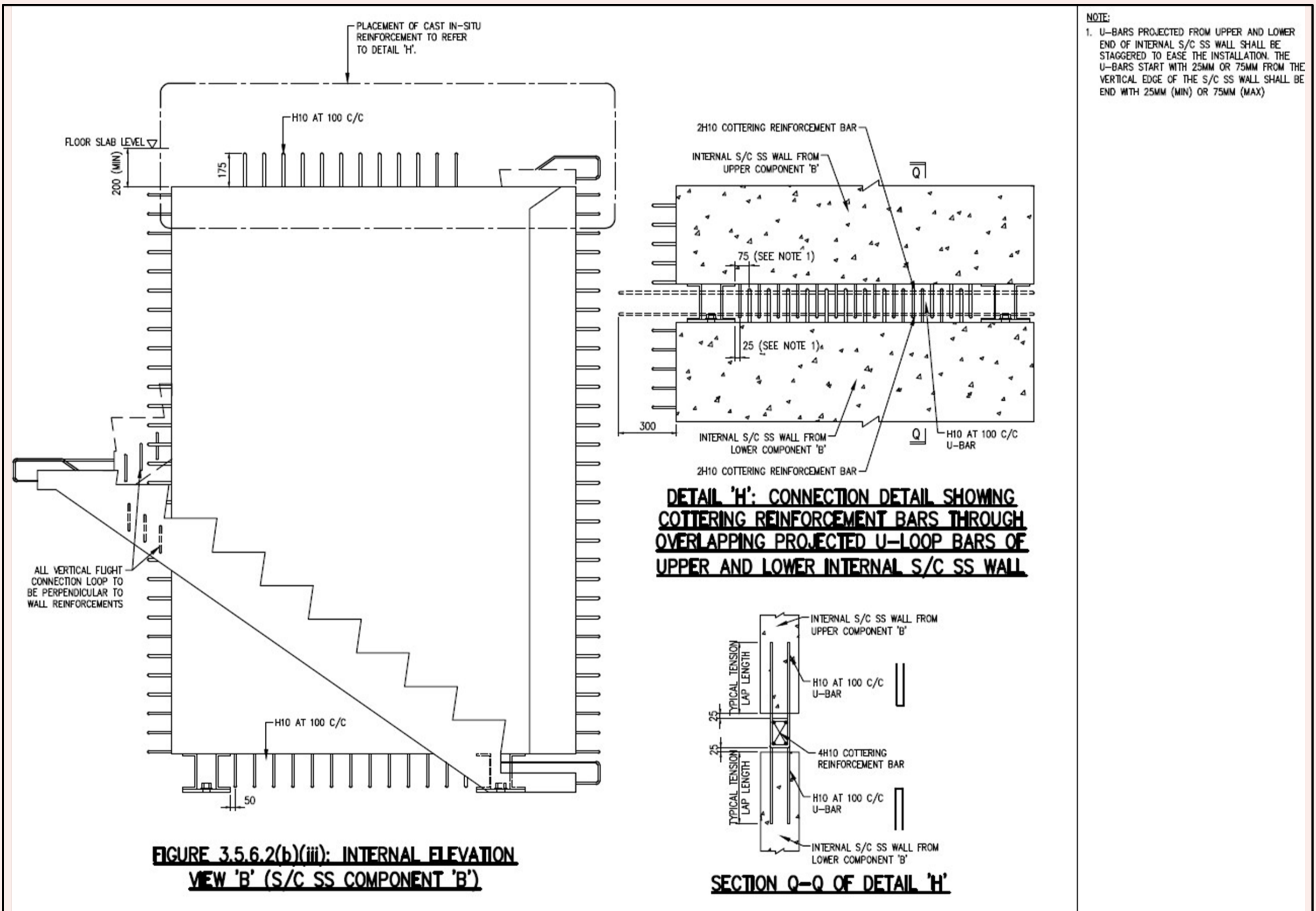

FIGURE 3.5.6.2(b)(iv) & FIGURE 3.5.6.2(b)(v) & FIGURE 3.5.6.2(b)(vi)

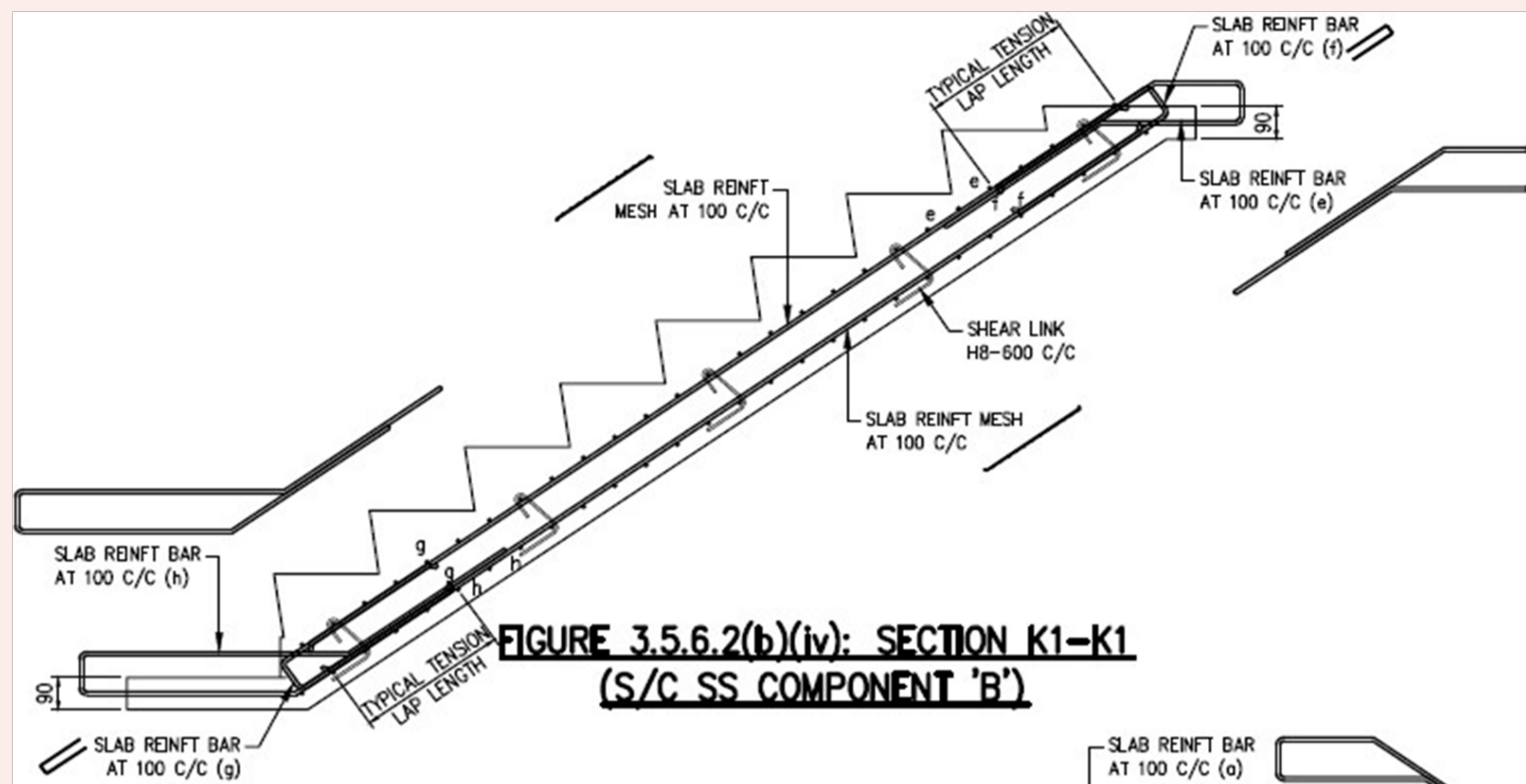

FIGURE 3.5.6.2(b)(iv): SECTION K1-K1 (S/C SS COMPONENT 'B')

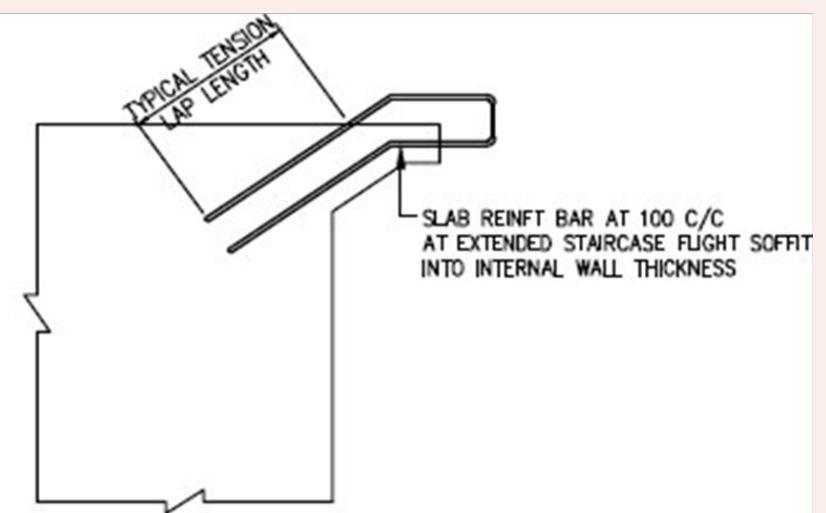

FIGURE 3.5.6.2(b)(v): SECTION K2-K2 (S/C SS COMPONENT 'B') AT INTERNAL WALL LOCATION

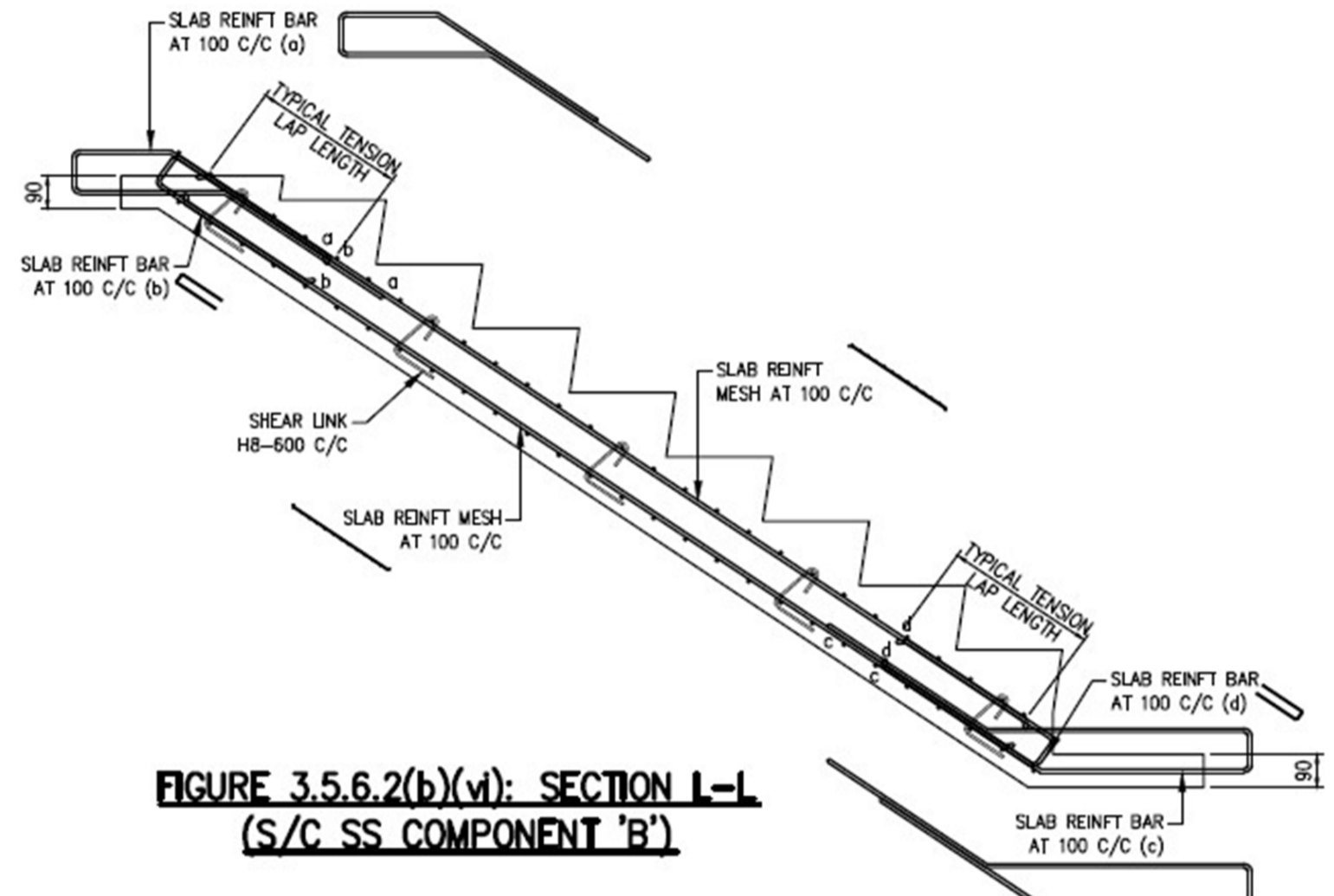
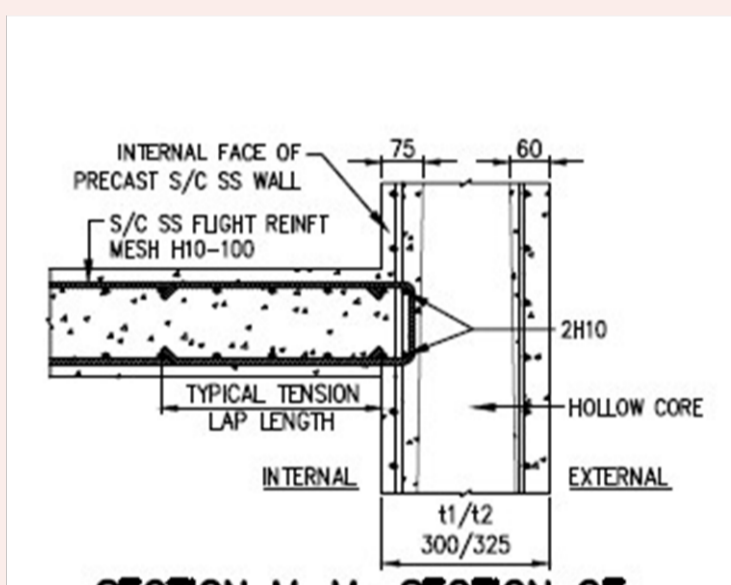
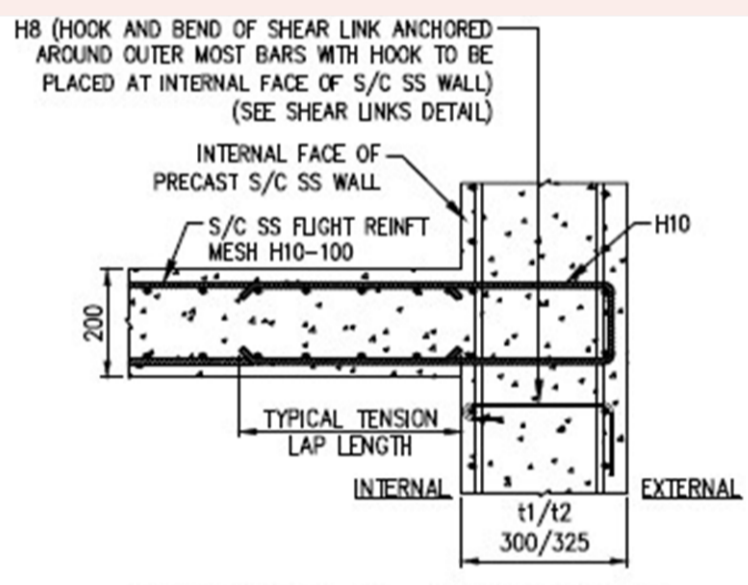

FIGURE 3.5.6.2(b)(vi): SECTION L-L (S/C SS COMPONENT 'B')



SECTION M-M: SECTION OF STAIRCASE FLIGHT AT HOLLOW CORE



SECTION N-N: SECTION OF STAIRCASE FLIGHT AT RIB

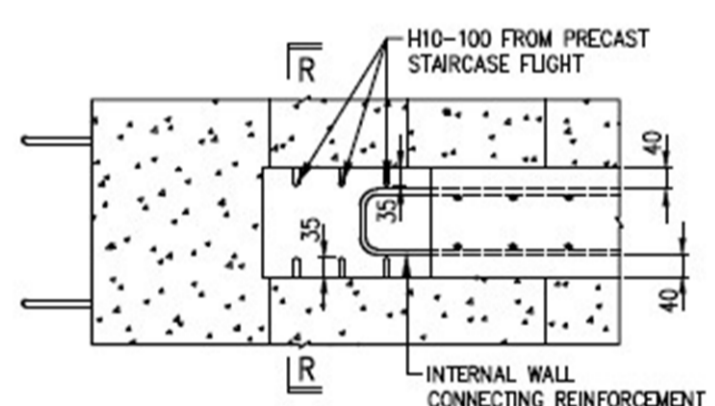

DETAIL 'F': STAIRCASE FLIGHT REINFORCEMENT CAST IN-SITU LOCATION

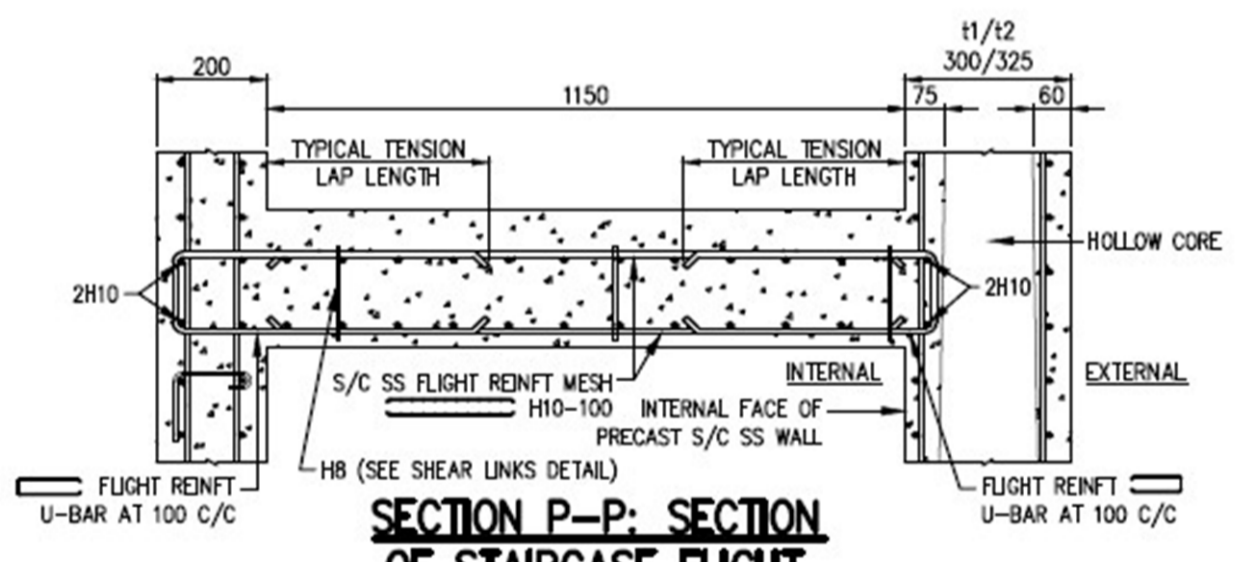

SECTION P-P: SECTION OF STAIRCASE FLIGHT

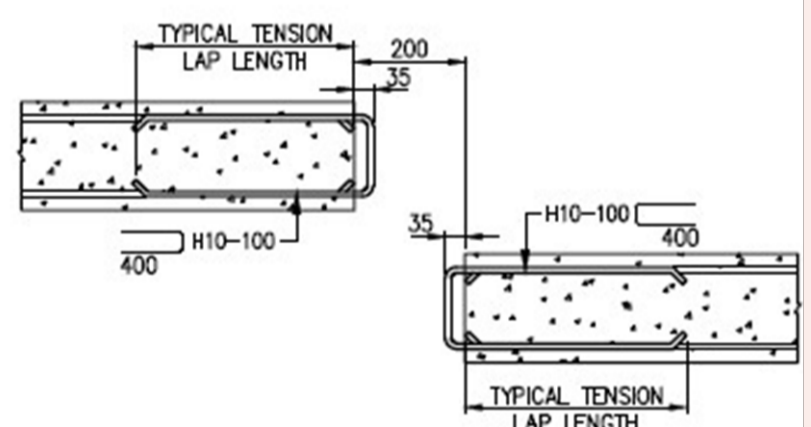

SECTION R-R: SECTION OF STAIRCASE FLIGHT CAST IN-SITU JOINT LOCATION

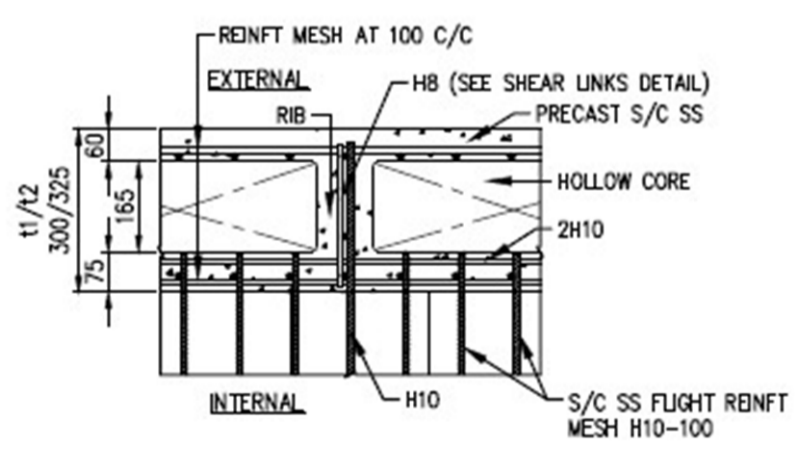

DETAIL 'G': STAIRCASE FLIGHT REINFORCEMENT AT RIB AND HOLLOW CORE

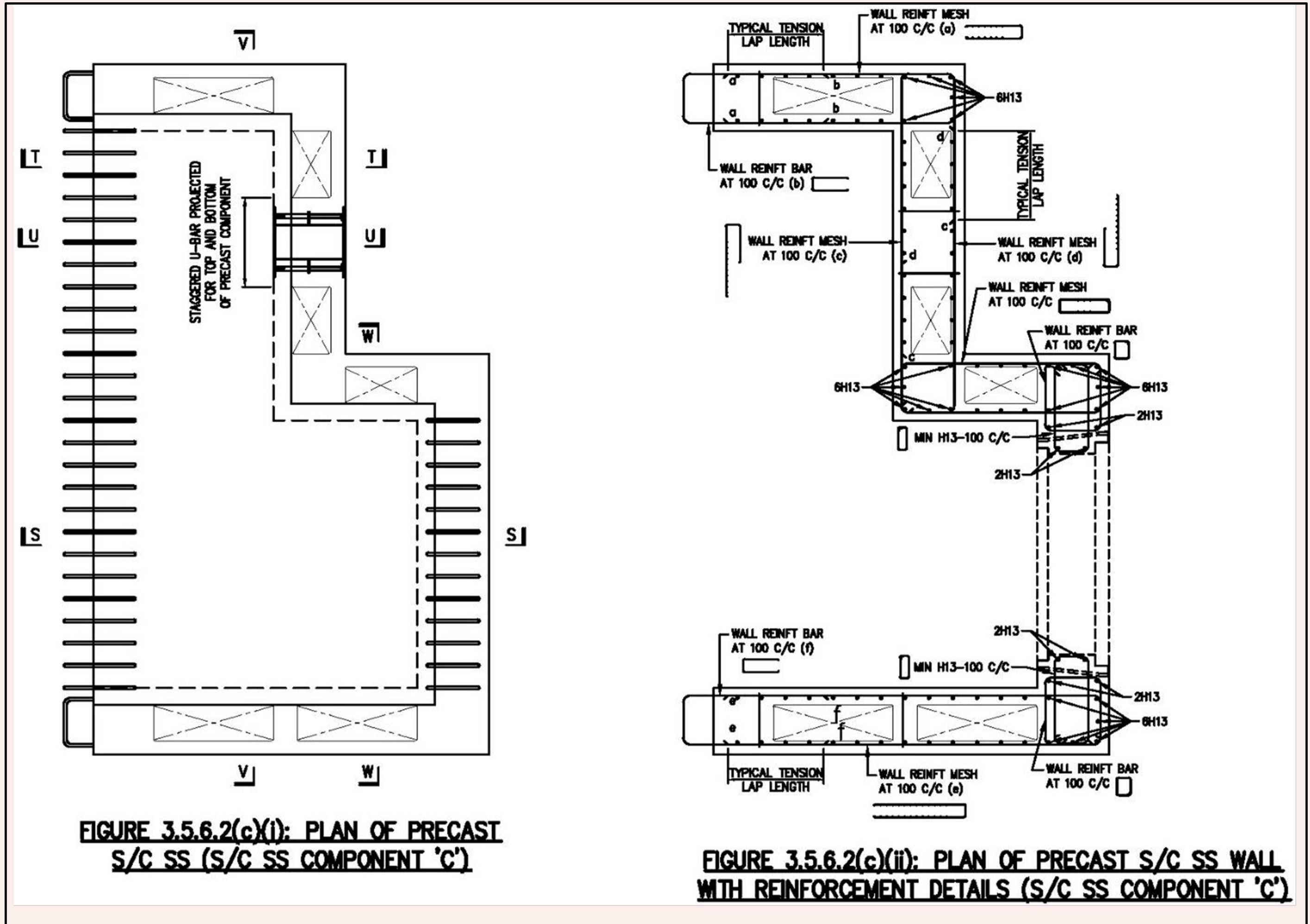

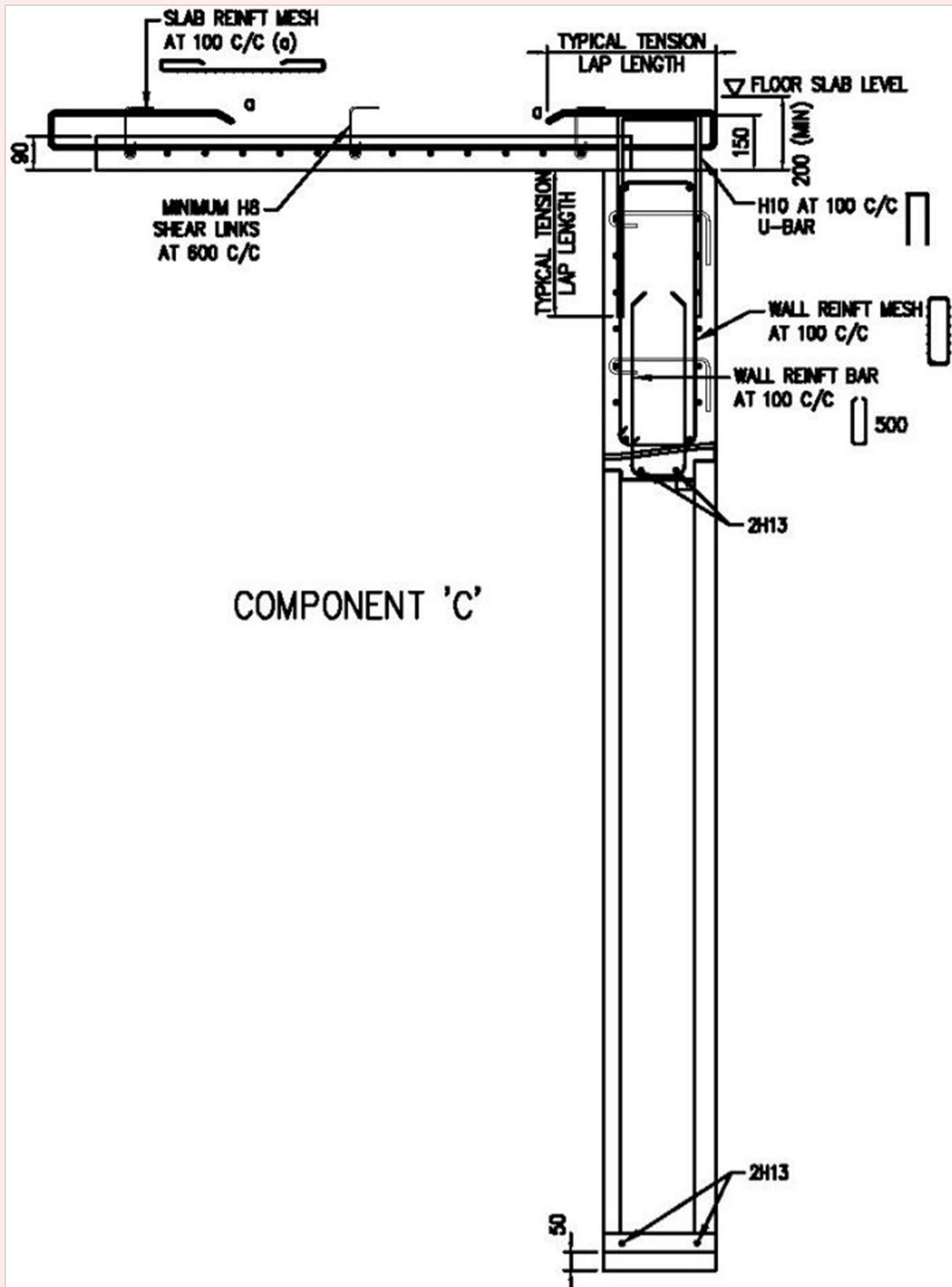

COMPONENT 'C'

**FIGURE 3.5.6.2(c)(iii): SECTION S-S
(S/C SS COMPONENT 'C')**

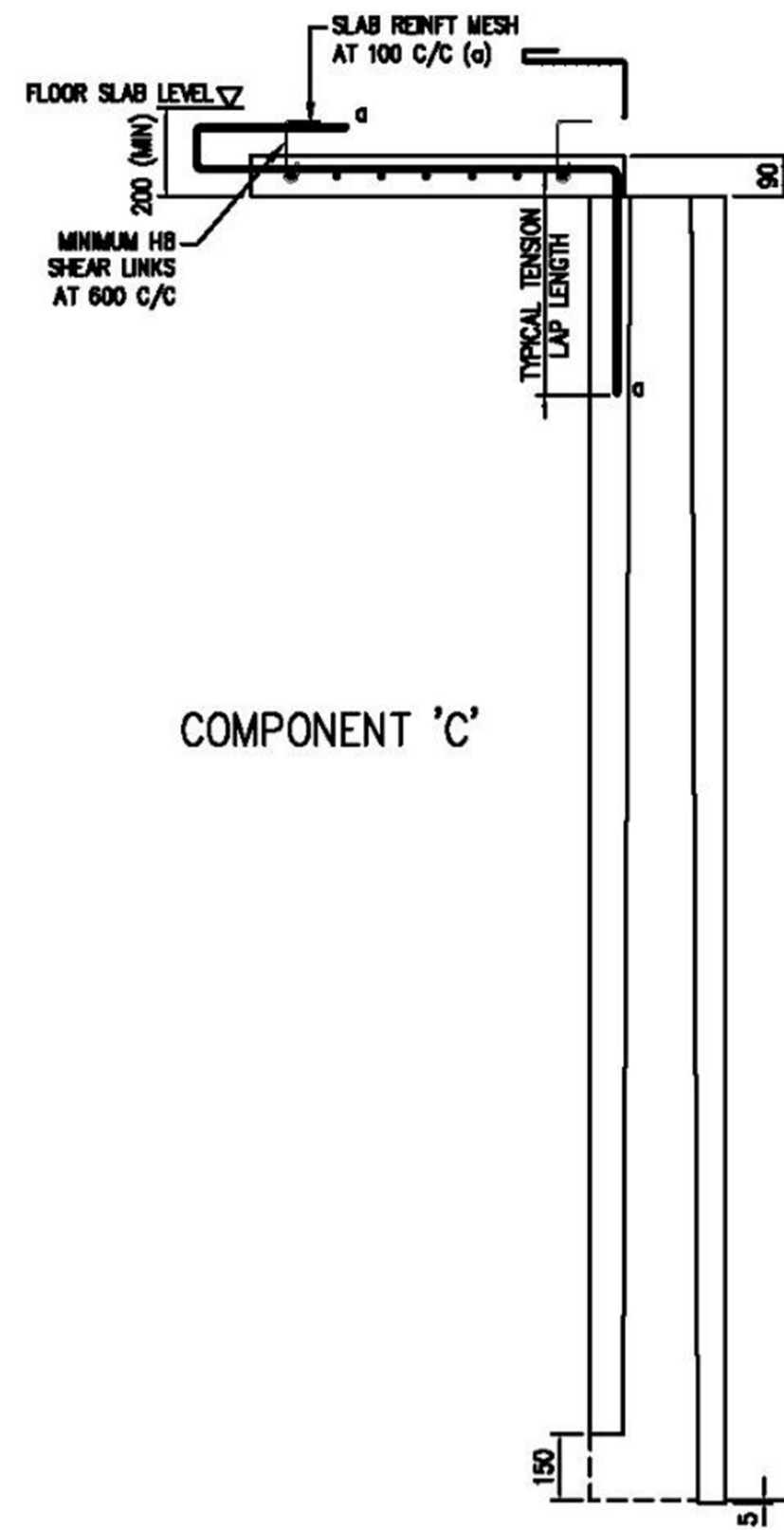

COMPONENT 'C'

**FIGURE 3.5.6.2(c)(iv): SECTION T-T
(S/C SS COMPONENT 'C')**

FIGURE 3.5.6.2 (c)(v) & FIGURE (c)(vi)

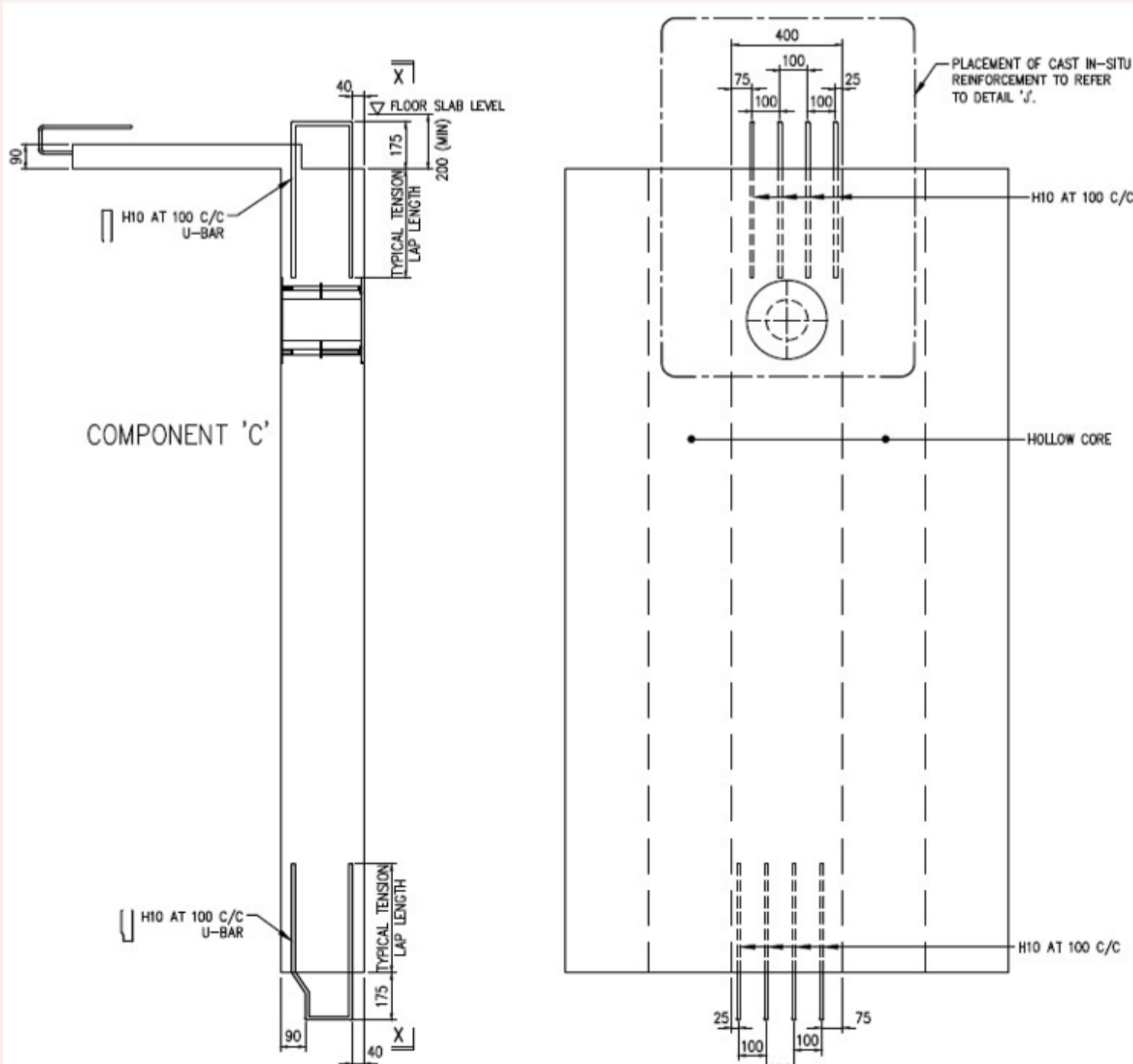

COMPONENT 'C'

**FIGURE 3.5.6.2(c)(v): SECTION
U-U AT VENTILATION SLEEVE
(S/C SS COMPONENT 'C')**

**FIGURE 3.5.6.2(c)(vi): SECTION
X-X AT VENTILATION SLEEVE
(S/C SS COMPONENT 'C')**

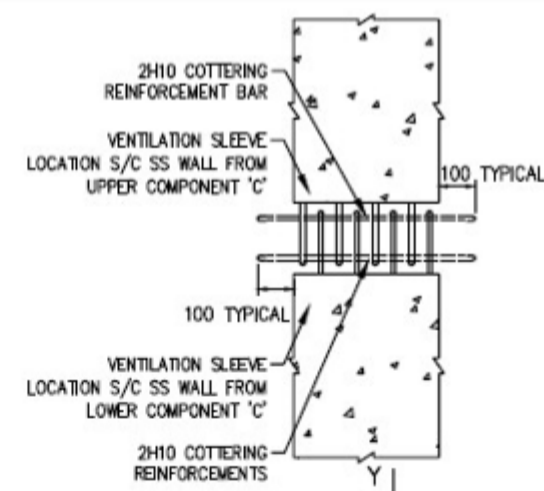

**DETAIL 'J': CONNECTION DETAIL SHOWING
COTTERING REINFORCEMENT BARS
THROUGH OVERLAPPING PROJECTED
U-LOOP BARS OF UPPER AND LOWER
S/C SS WALL WITH VENTILATION SLEEVE**

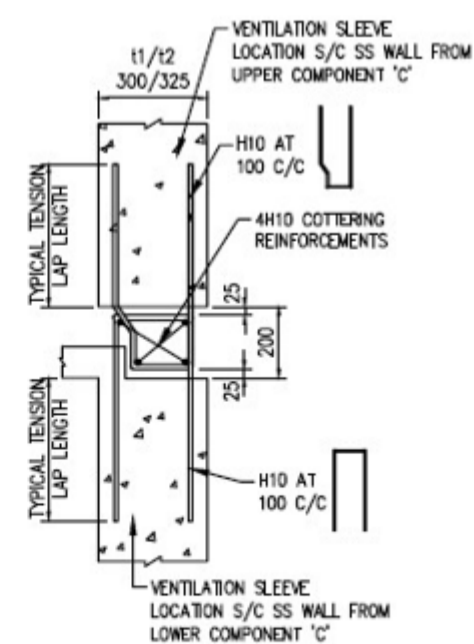

**SECTION Y-Y
OF DETAIL 'J'**

FIGURE 3.5.6.2 (c)(vii) & FIGURE (c)(viii)

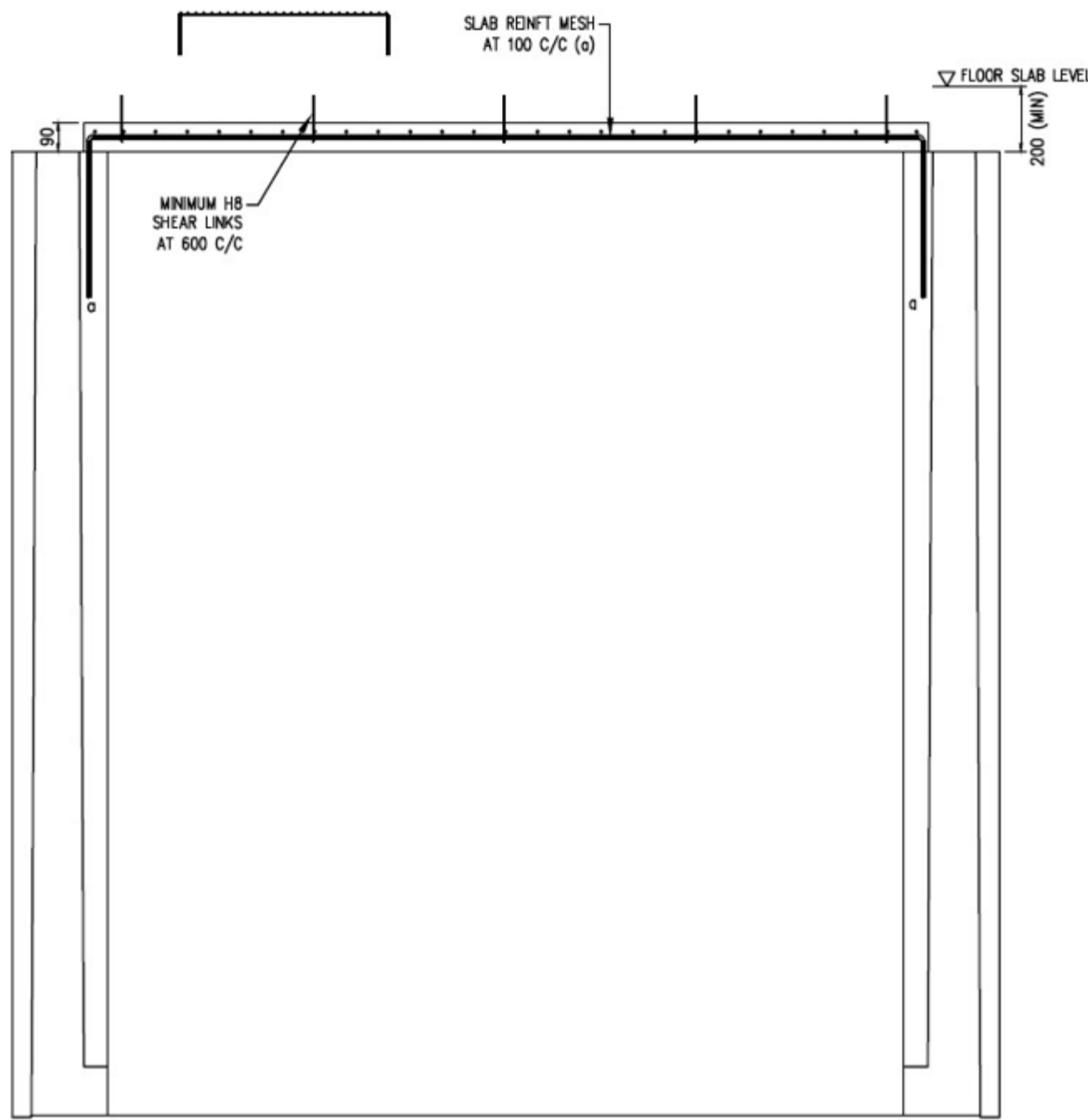

FIGURE 3.5.6.2(c)(vii): SECTION Y-V (S/C SS COMPONENT 'C')

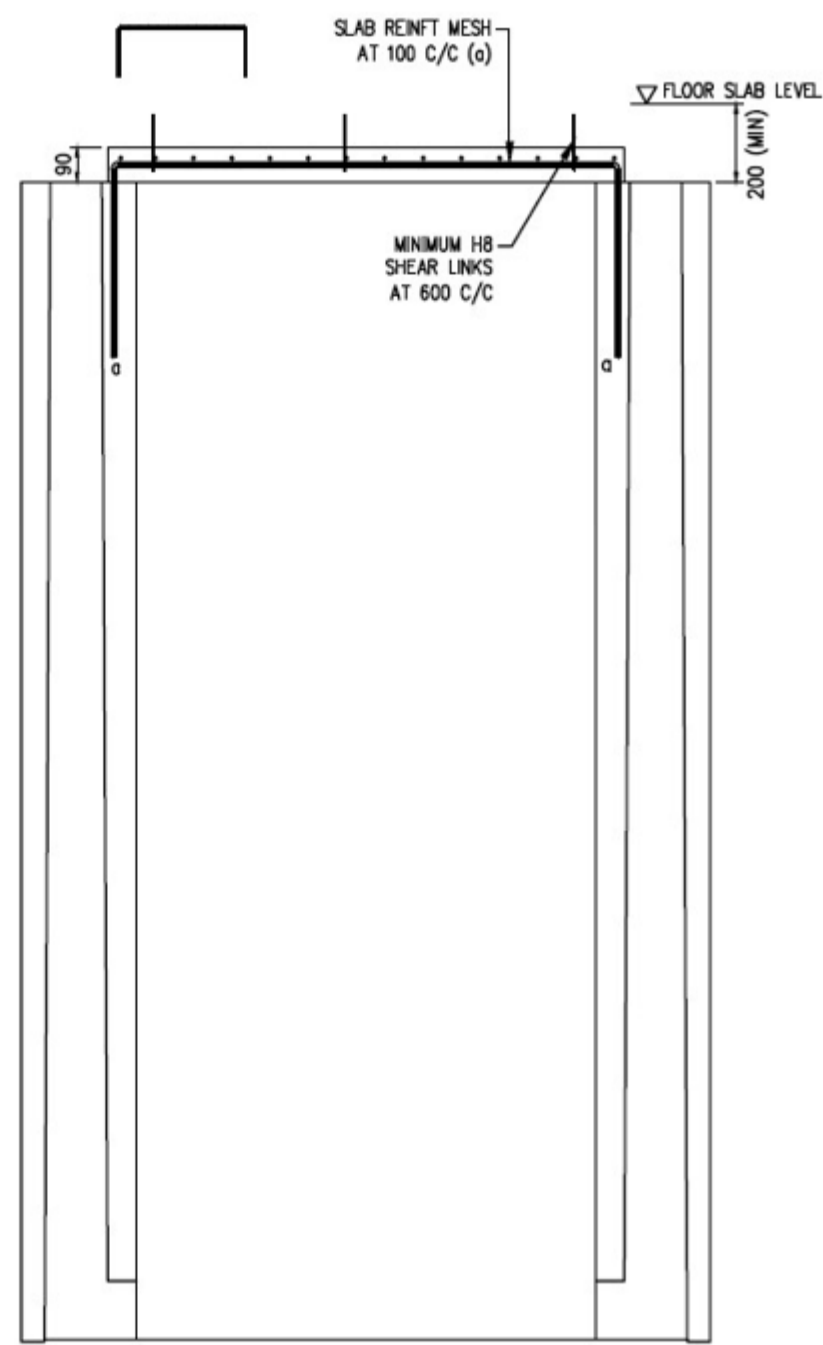

FIGURE 3.5.6.2(c)(viii): SECTION W-W (S/C SS COMPONENT 'C')

FIGURE 3.5.6.2(d)

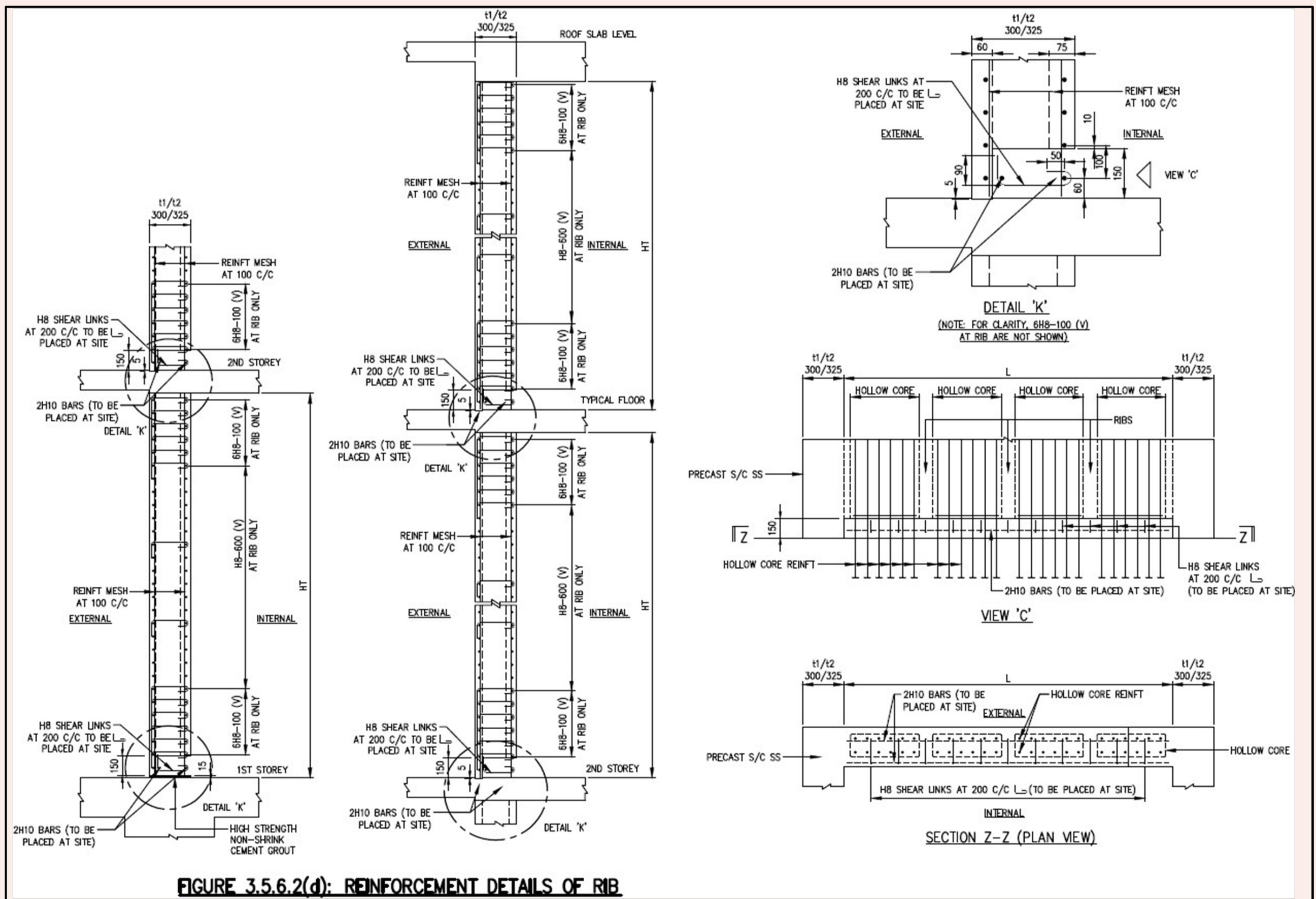

FIGURE 3.5.6.2(d): REINFORCEMENT DETAILS OF RIB

FIGURE 3.5.6.2(e)

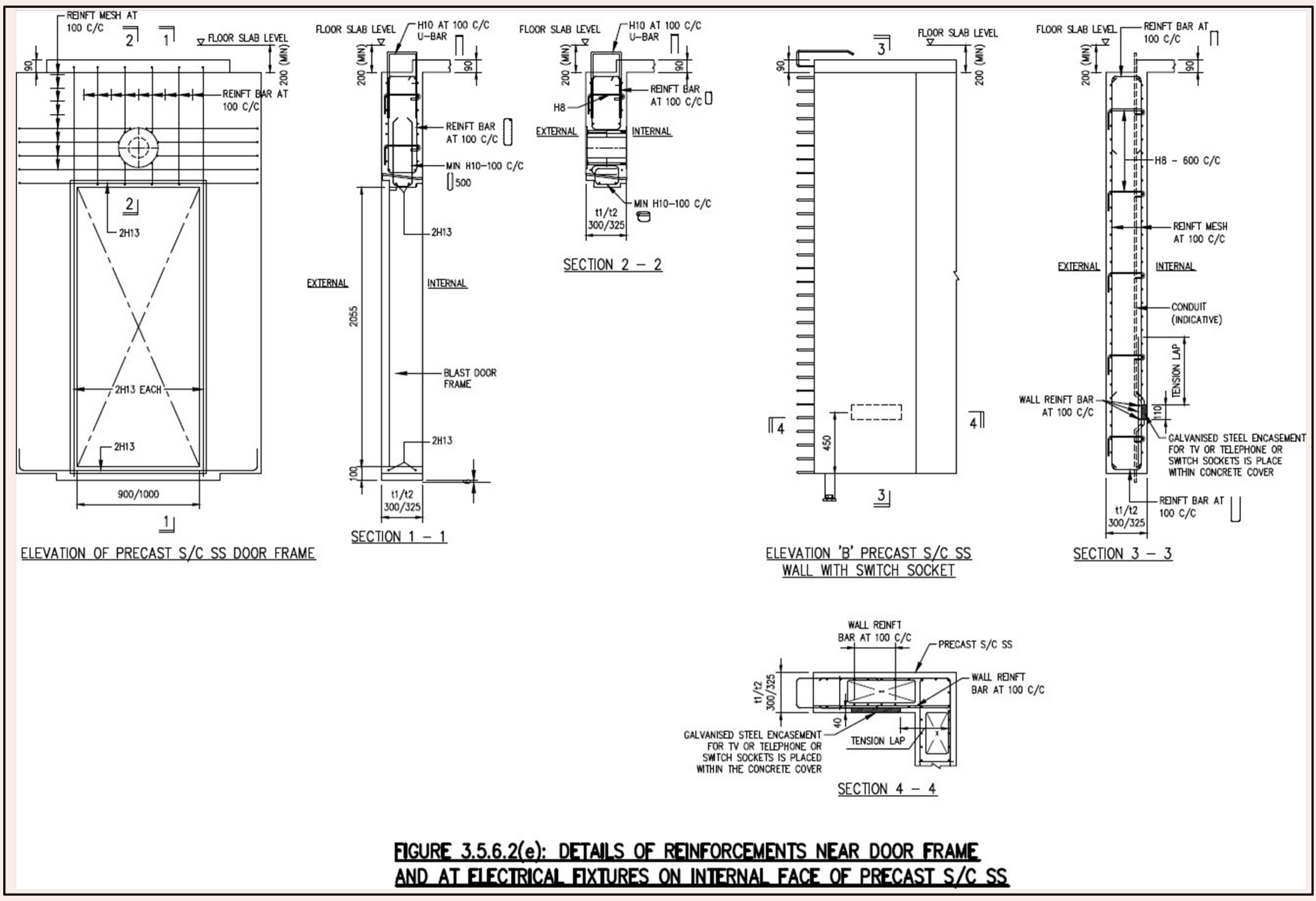

FIGURE 3.5.6.2(f), FIGURE 3.5.6.2(g) & FIGURE 3.5.6.2(h)

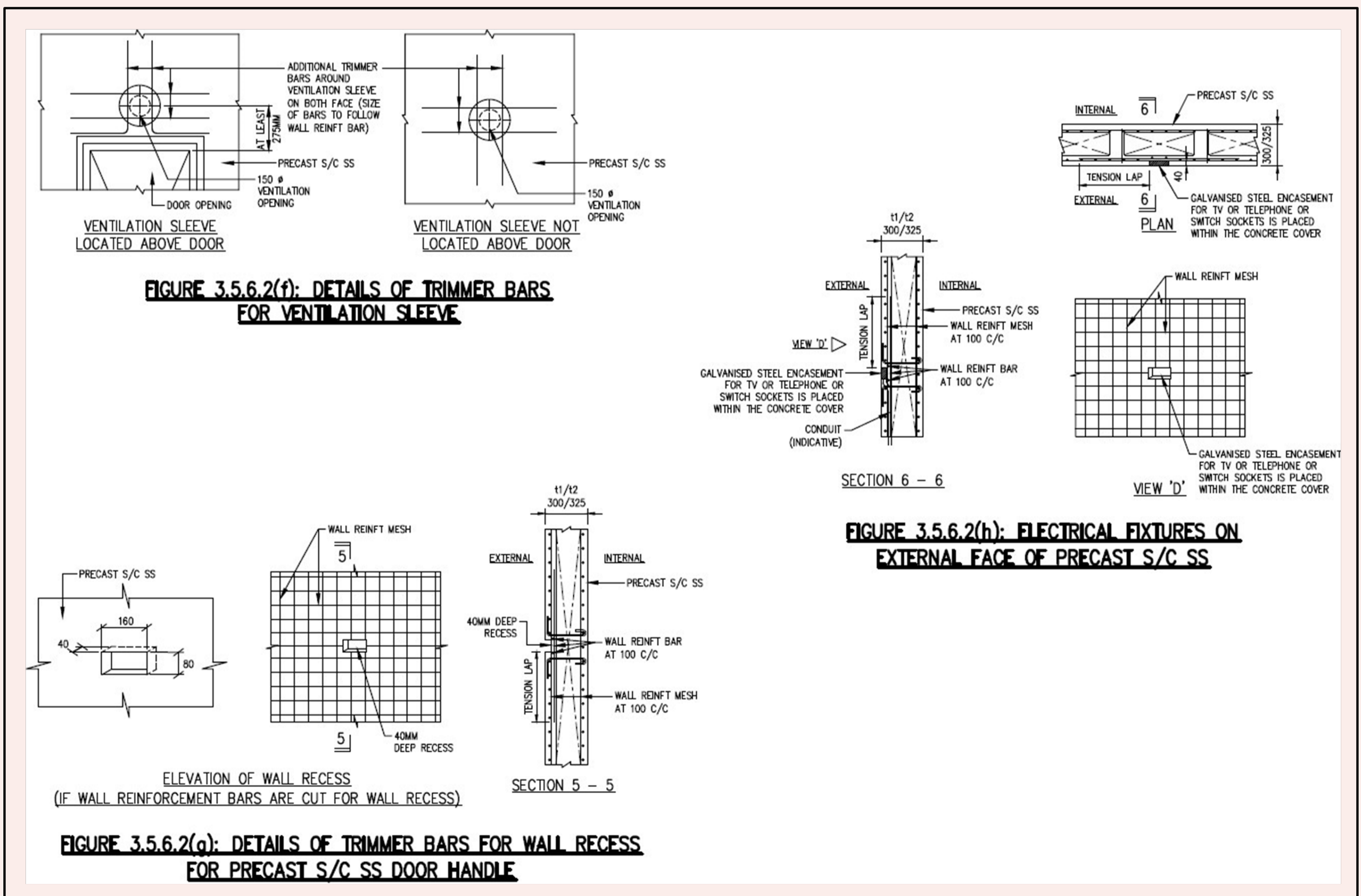

FIGURE 3.5.6.2(i) & FIGURE 3.5.6.2 (j)

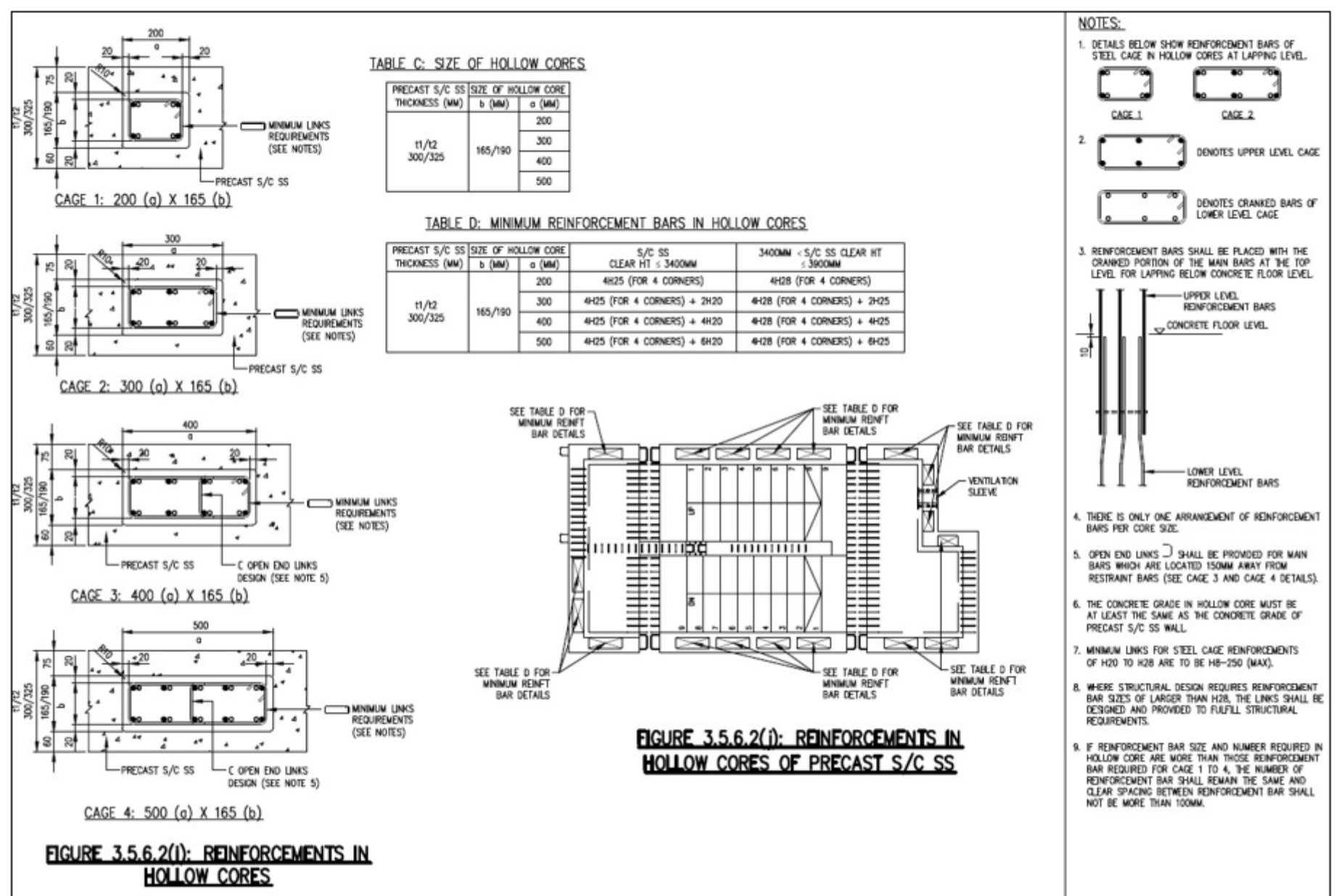
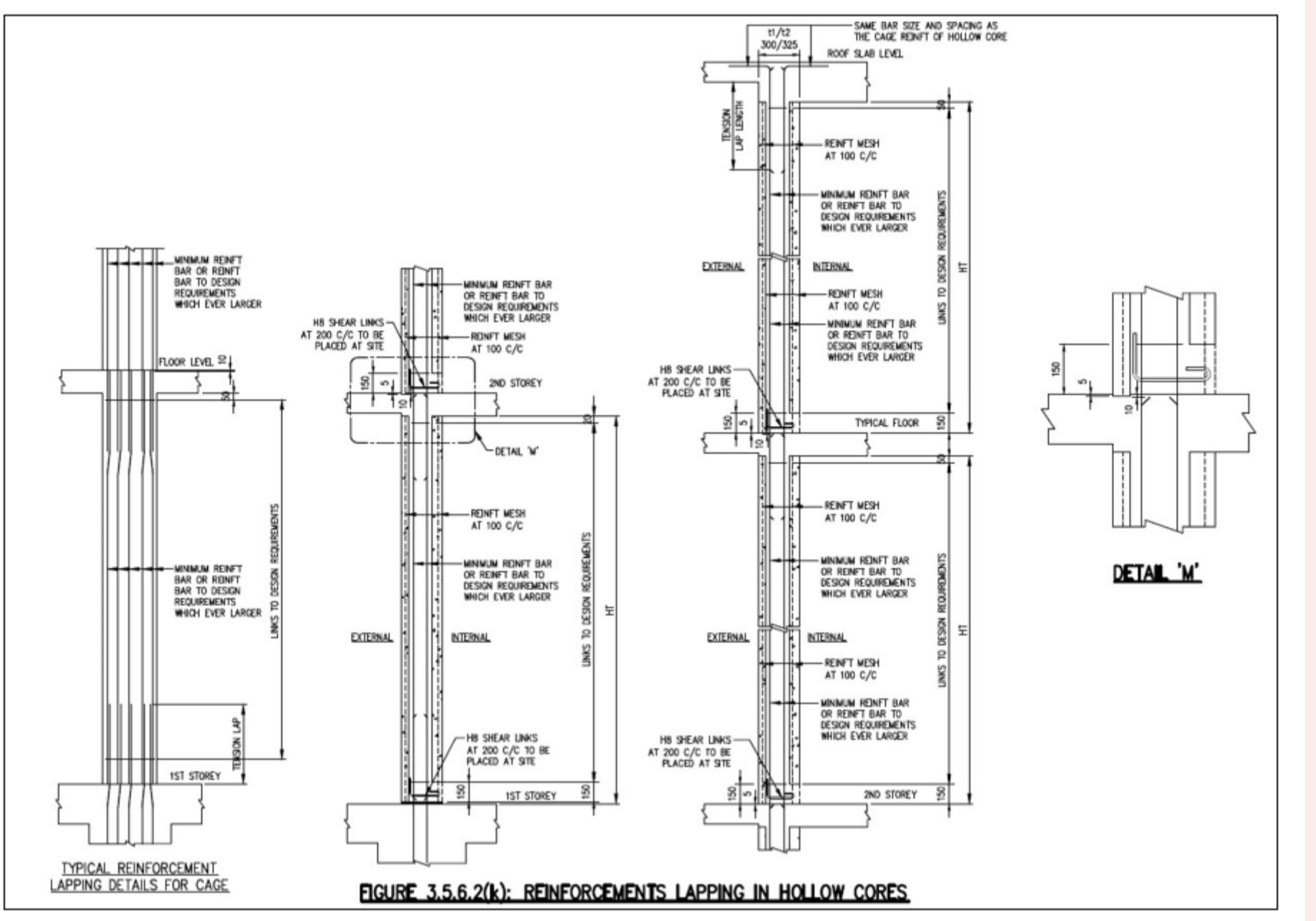

FIGURE 3.5.6.2(k)



3.5.6.2 Reinforcement Requirements

FIGURE 3.5.6.2(a)(i)	Plan of Precast S/C SS (Component 'A')
FIGURE 3.5.6.2(a)(ii)	Plan of Precast S/C SS Wall with Reinforcement Details at Blast Hatch Opening (S/C SS Component 'A')
FIGURE 3.5.6.2(a)(iii)	Plan of Precast S/C SS Wall with Reinforcement Details above Blast Hatch Opening (S/C SS Component 'A')
FIGURE 3.5.6.2(a)(iv)	Section D-D (S/C SS Component 'A')
FIGURE 3.5.6.2(a)(v)	Section E-E (S/C SS Component 'A')
FIGURE 3.5.6.2(a)(vi)	Section F-F (S/C SS Component 'A')
FIGURE 3.5.6.2(a)(vii)	Section G-G (S/C SS Component 'A')
FIGURE 3.5.6.2(a)(viii)	Section H-H (S/C SS Component 'A')
FIGURE 3.5.6.2(b)(i)	Plan of Precast S/C SS (S/C SS Component 'B')
FIGURE 3.5.6.2(b)(ii)	Plan of Precast S/C SS Wall with Reinforcement Details (S/C SS Component 'B')

FIGURE 3.5.6.2(b)(iii)	Internal Elevation View 'B' (S/C SS Component 'B')
FIGURE 3.5.6.2(b)(iv)	Section K1-K1 (S/C SS Component 'B')
FIGURE 3.5.6.2(b)(v)	Section K2-K2 (S/C SS Component 'B')
FIGURE 3.5.6.2(b)(vi)	Section L-L (S/C SS Component 'B')
FIGURE 3.5.6.2(c)(i)	Plan of Precast S/C SS (Component 'C')
FIGURE 3.5.6.2(c)(ii)	Plan of Precast S/C SS Wall with Reinforcement Details (S/C SS Component 'C')
FIGURE 3.5.6.2(c)(iii)	Section S-S (S/C SS Component 'C')
FIGURE 3.5.6.2(c)(iv)	Section T-T (S/C SS Component 'C')
FIGURE 3.5.6.2(c)(v)	Section U-U at Ventilation Sleeve (S/C SS Component 'C')
FIGURE 3.5.6.2(c)(vi)	Section X-X at Ventilation Sleeve (S/C SS Component 'C')
FIGURE 3.5.6.2(c)(vii)	Section V-V (S/C SS Component 'C')
FIGURE 3.5.6.2(c)(viii)	Section W-W (S/C SS Component 'C')
FIGURE 3.5.6.2(d)	Reinforcement details of Rib
FIGURE 3.5.6.2(e)	Details of Reinforcements near Door Frame and at Electrical Fixtures on Internal Face of Precast SSS
FIGURE 3.5.6.2(f)	Details of Trimmer Bars for Ventilation Sleeve
FIGURE 3.5.6.2(g)	Details of Trimmer Bars for Wall Recess for Precast S/C SS Door Handle
FIGURE 3.5.6.2(h)	Electrical Fixtures on External Face of Precast S/C SS
FIGURE 3.5.6.2(i)	Reinforcements in Hollow Cores
FIGURE 3.5.6.2(j)	Reinforcements in Hollow Cores of Precast S/C SS
FIGURE 3.5.6.2(k)	Reinforcements Lapping in Hollow Cores

d. For the rib between two hollow cores of precast S/C SS, its top and bottom portion shall be provided with closer shear links of at least 6 numbers of H8 at maximum 100mm c/c spacing as shown in FIGURE 3.5.6.2(d). For area between these top and bottom portions, minimum shear links of at least H8 at maximum 600mm c/c spacing shall be provided as shown in FIGURE 3.5.6.2(d). The hook of the shear links must be anchored around the outermost reinforcements of the internal face of precast S/C SS wall.

Figures & Tables

FIGURE 3.5.6.2(d)

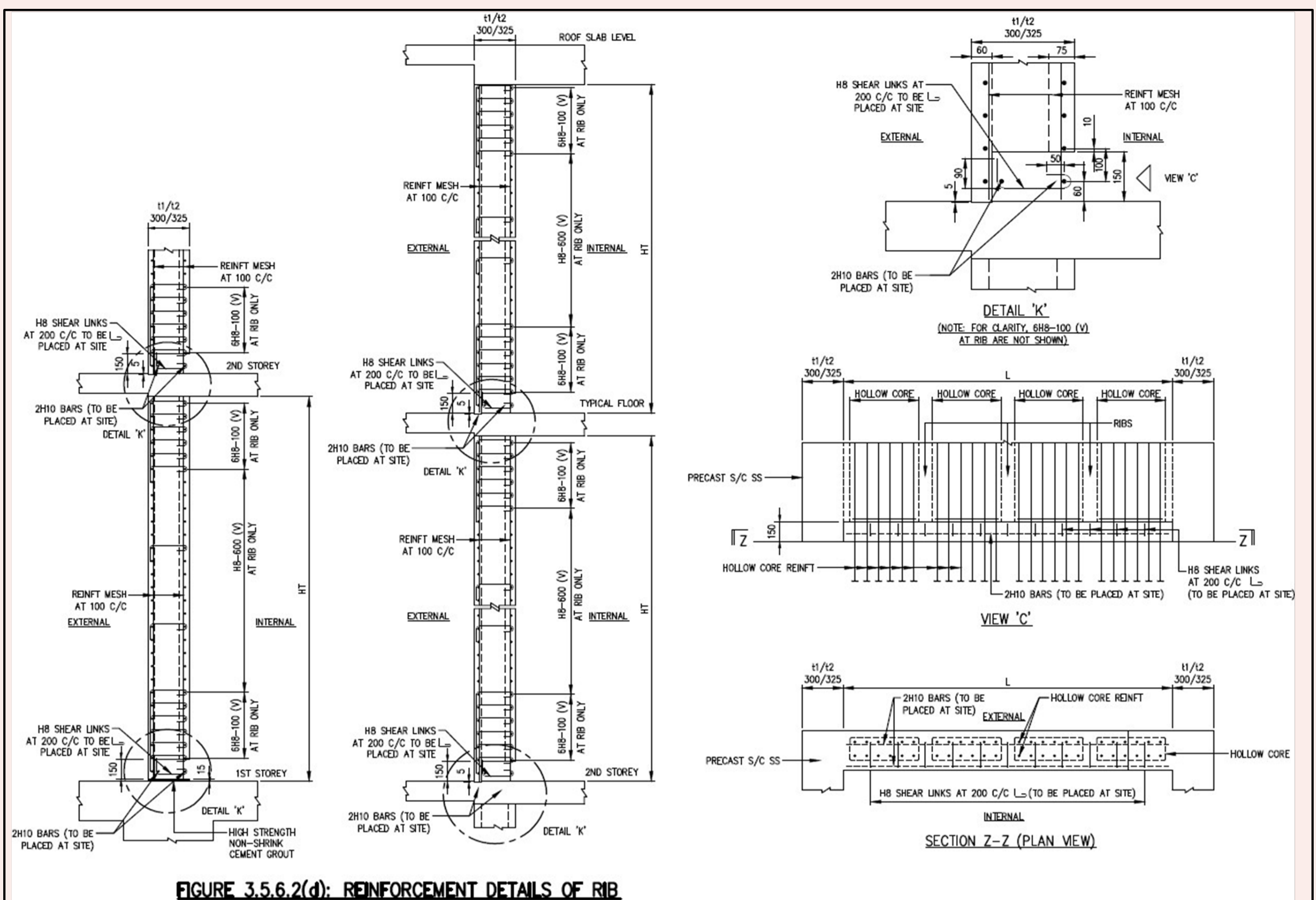

FIGURE 3.5.6.2(d): REINFORCEMENT DETAILS OF RIB

e. The reinforcements for the precast S/C SS door frame, ventilation sleeves, wall recess for electrical fixtures on internal face of precast S/C SS wall and wall recess for the external S/C SS door handle are shown in FIGURE 3.5.6.2(f) to 3.5.6.2(h).

Figures & Tables

FIGURE 3.5.6.2(f) to 3.5.6.2(h)

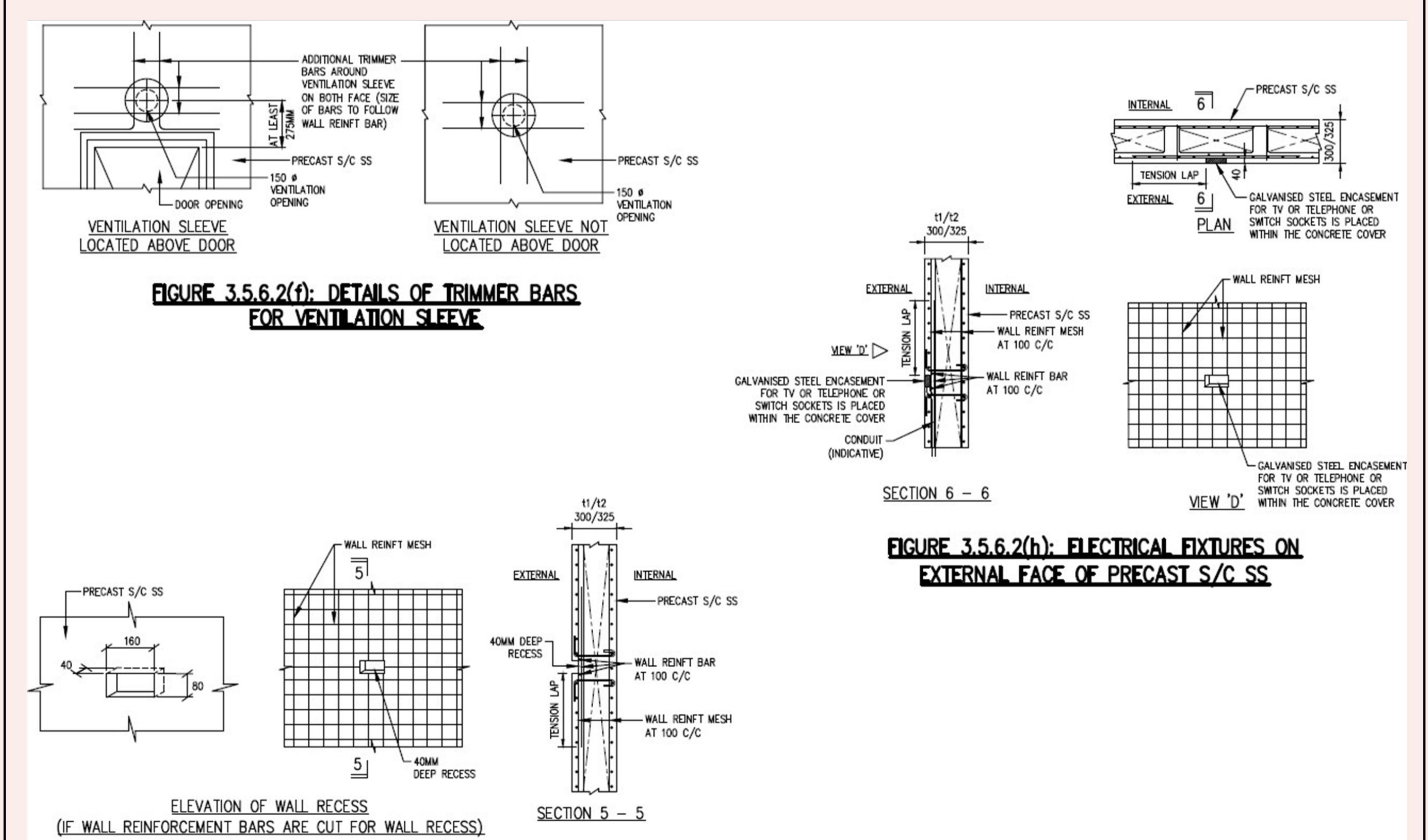

FIGURE 3.5.6.2(f): DETAILS OF TRIMMER BARS FOR VENTILATION SLEEVE

FIGURE 3.5.6.2(h): ELECTRICAL FIXTURES ON EXTERNAL FACE OF PRECAST S/C SS

FIGURE 3.5.6.2(g): DETAILS OF TRIMMER BARS FOR WALL RECESS FOR PRECAST S/C SS DOOR HANDLE

f. The modular length of the hollow cores of precast S/C SS shall vary between minimum 200mm and maximum 500mm with increment of 100mm whereas the modular width of the hollow cores of precast S/C SS shall be 165mm and 190mm for S/C SS wall thickness of 300mm and 325mm respectively as shown in TABLE C of FIGURE 3.5.6.2(i). In these hollow cores, minimum reinforcements and links shall be provided and installed as shown in TABLE D of FIGURE 3.5.6.2(i) and 3.5.6.2(j). Higher reinforcements and links shall be provided if they are required to meet the structural safety and stability requirements.

Figures & Tables

FIGURE 3.5.6.2(i) and 3.5.6.2(j)

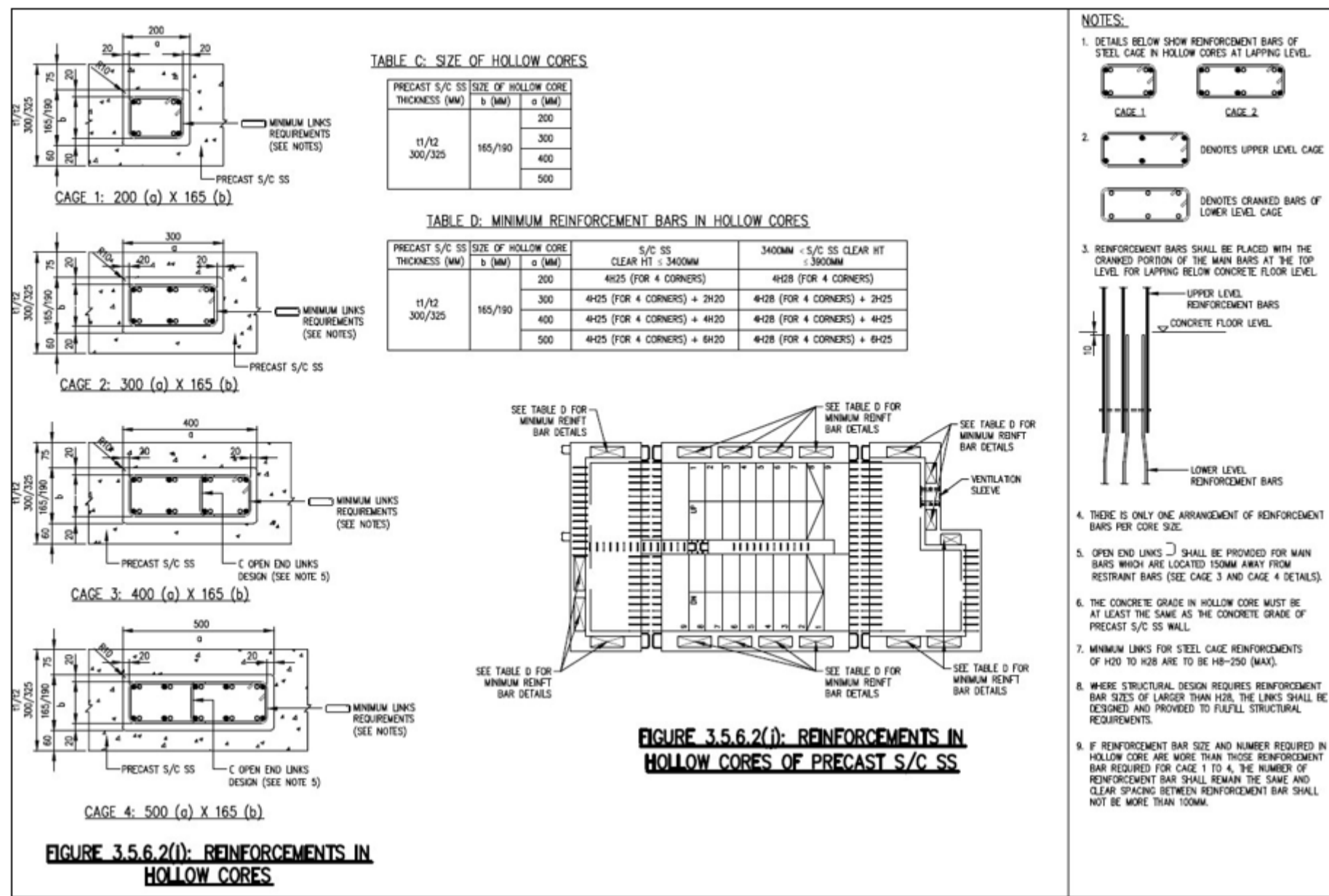

g. All reinforcement bars must be designed and detailed with full tension anchorage or lap length, complying with Clause 3.5.2. The reinforcements for hollow cores of precast S/C SS wall shall be cranked at their upper part to facilitate placing of the reinforcements at lapping level as shown in FIGURE 3.5.6.2(k).

Figures & Tables

FIGURE 3.5.6.2(k)

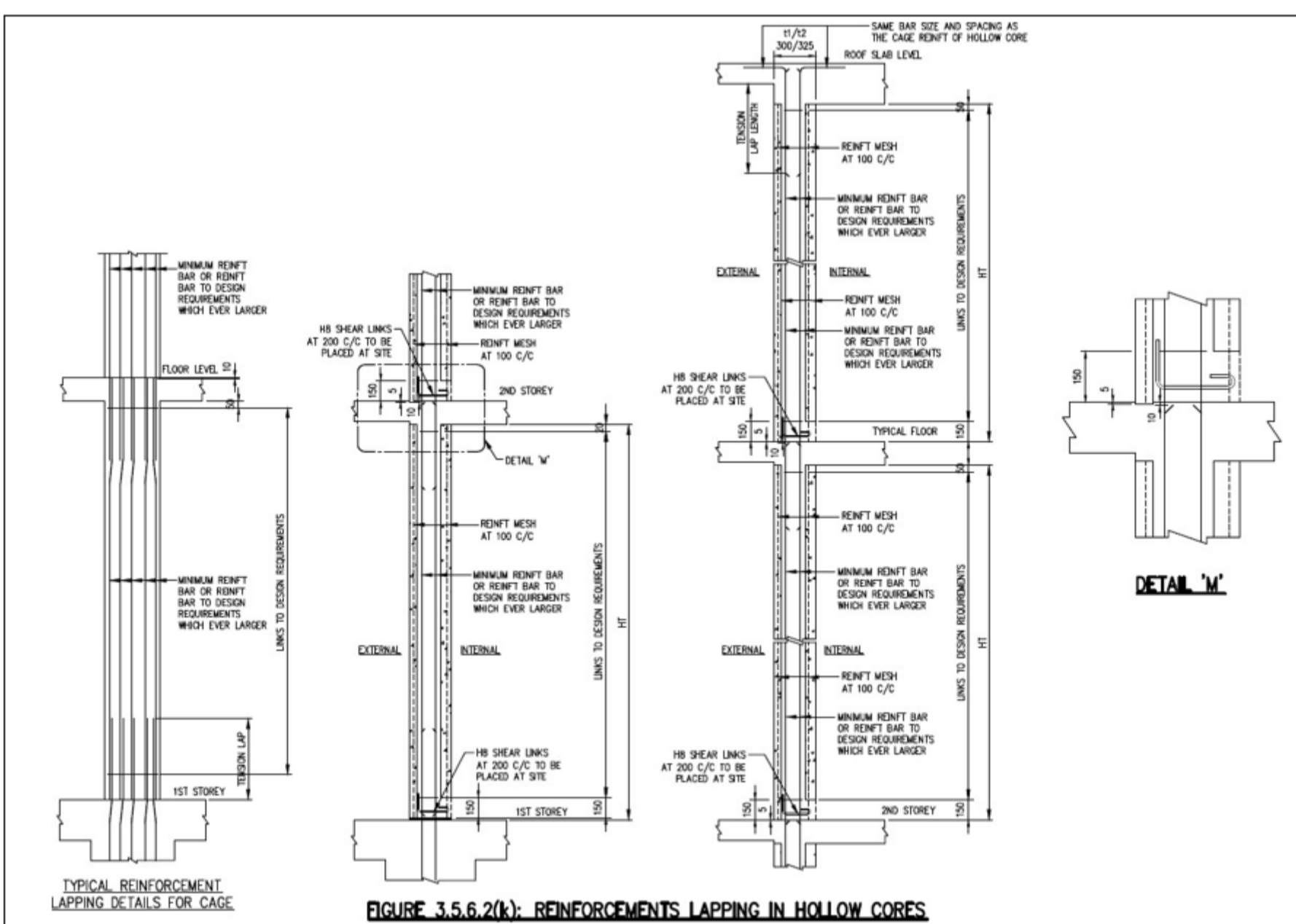

3.5.6.3 Connection between Precast Hollow Core Staircase Storey Shelters

a. The connection between Precast S/C SS hollow cores are shown in FIGURE 3.5.6.3(a) to 3.5.6.3(c):

Figures & Tables

FIGURE 3.5.6.3(a) to 3.5.6.3(c)

FIGURE 3.5.6.3(a)

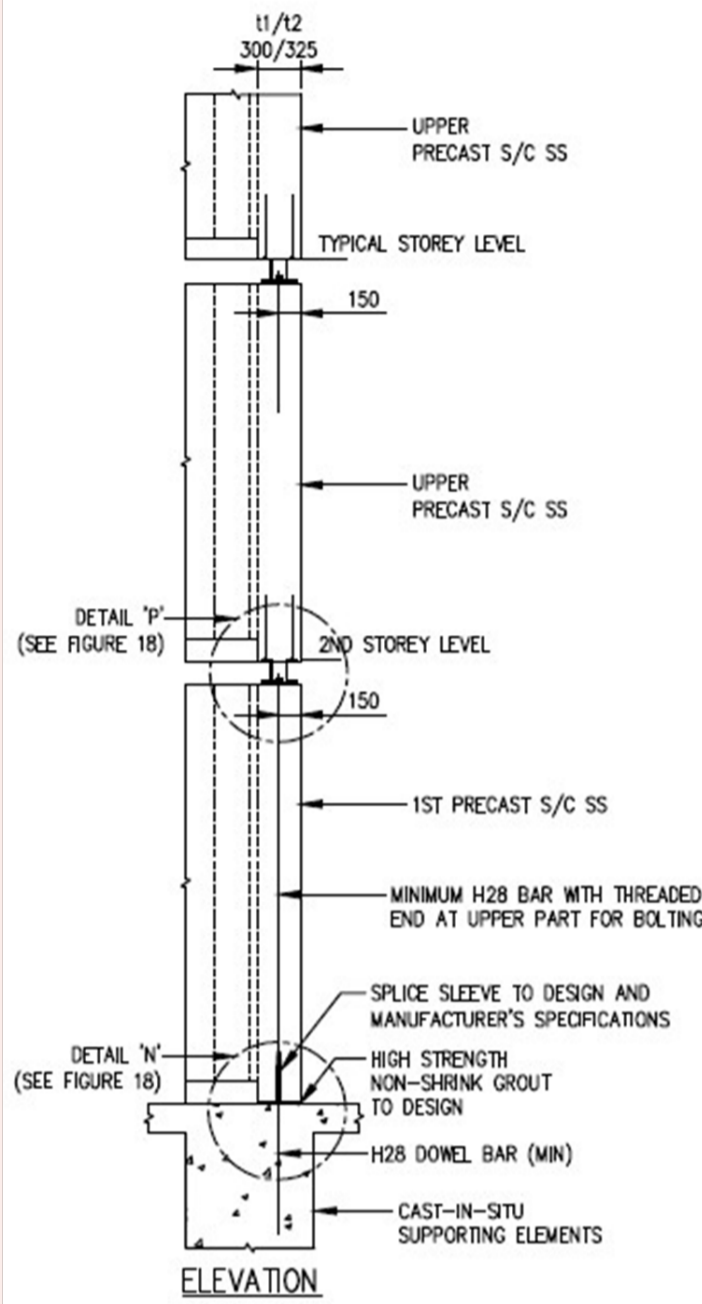

FIGURE 3.5.6.3(a): SPLICE SLEEVE CONNECTION DETAILS BETWEEN PRECAST S/C SS AND CAST IN-SITU ELEMENT AND BOLT CONNECTION DETAILS BETWEEN TWO PRECAST S/C SS

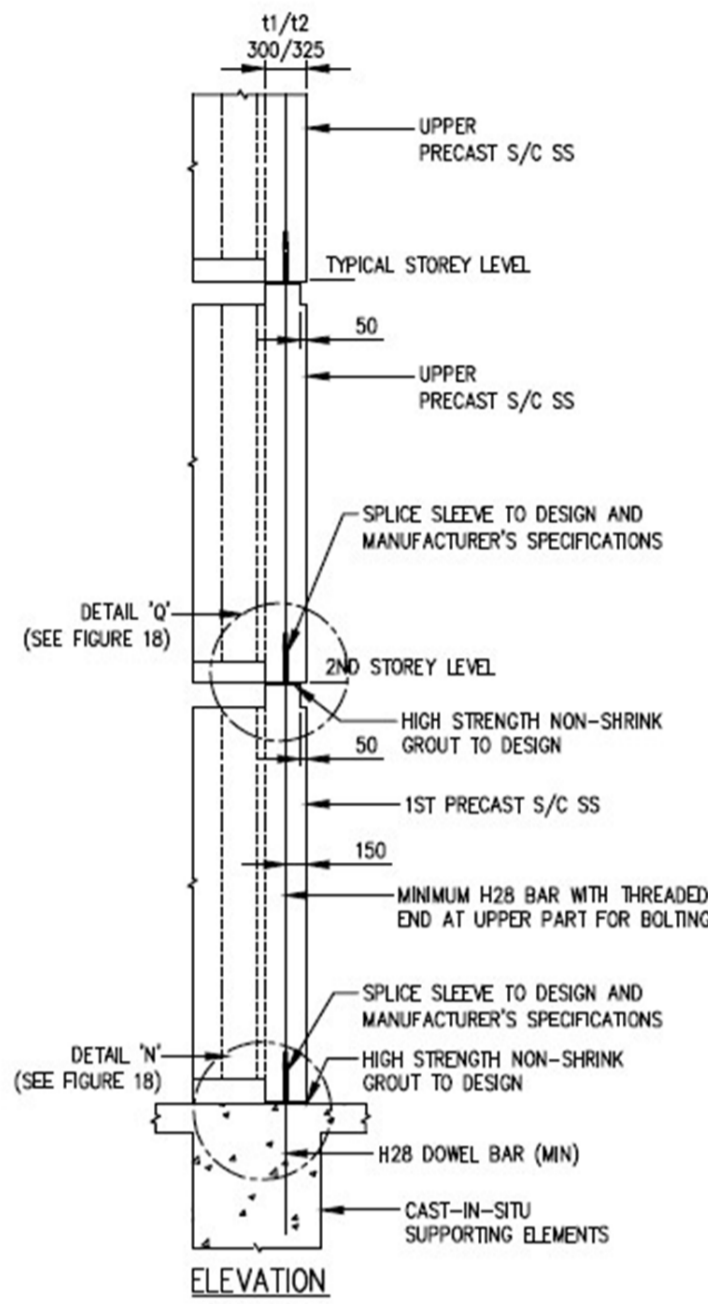
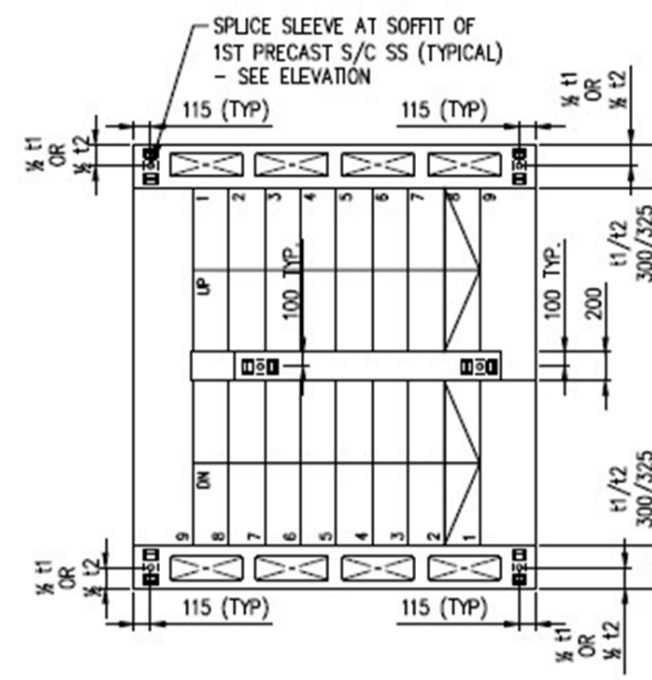
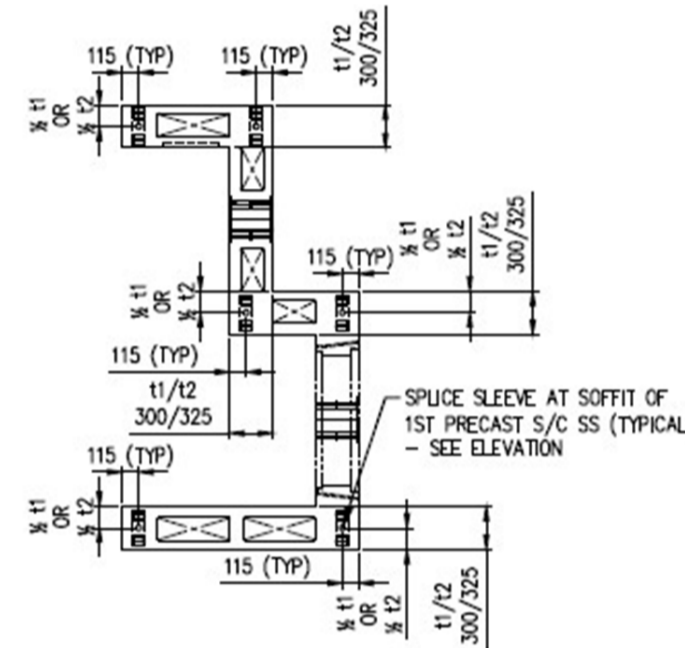

FIGURE 3.5.6.3(b): SPLICE SLEEVE CONNECTION DETAILS FOR PRECAST S/C SS TOWER



REFERENCE PLAN FOR 1ST STOREY COMPONENT 'B' PRECAST S/C SS (SIZE AND ARRANGEMENT OF CORES SHOWN IS INDICATIVE ONLY)



REFERENCE PLAN FOR 1ST STOREY COMPONENT 'C' PRECAST S/C SS (SIZE AND ARRANGEMENT OF CORES SHOWN IS INDICATIVE ONLY)

NOTES:

1. THE 1ST OR LOWEST PRECAST STOREY SHELTER MUST BE CONNECTED BY SPLICE SLEEVE (DETAIL 'N', FIGURE 18) AT 4 CORNERS OR OTHER LOCATIONS OF SHELTER WALL. MINIMUM H28 DOWEL BAR FOR SPLICE SLEEVE SHALL BE CAST IN THE CAST IN-SITU SUPPORTING ELEMENTS (WALL, COLUMN, BEAM OR FOUNDATION).
2. THE UPPER PRECAST STOREY SHELTERS SHALL BE JOINED BY BOLT AND STEEL PLATE CONNECTION (SEE FIGURE 16 FOR DETAIL 'P' AND FIGURE 18 FOR SECTION 9-9, SECTION 10-10 AND DETAIL 'P') AT THEIR 4 CORNERS OR OTHER LOCATION OF SHELTER WALL.
3. ALTERNATIVE TO THE ABOVE NOTE 2, SPLICE SLEEVE CONNECTION CAN BE USED FOR PRECAST S/C SS TOWER (SEE FIGURE 17 FOR DETAIL 'Q' AND FIGURE 18 FOR SECTION 11-11 AND DETAIL 'Q').
4. HOT ROLLED STEEL SECTION OR PLATE SHALL BE GRADE S275.
5. H28 BARS REQUIRED FOR THESE TWO TYPES OF CONNECTION SHALL BE PROPERLY SECURED IN POSITION AT 4 TOP CORNERS OR OTHER LOCATIONS OF LOWER PRECAST S/C SS WALL WITH TEMPLATE SUCH THAT THEY ARE ALIGNED WITH THE BOLT HOLES OR SPLICE SLEEVE PROVIDED AT THE BASE OF THE UPPER PRECAST STAIRCASE STOREY SHELTER.
6. THE BOLT AND STEEL PLATE CONNECTION SHALL BE CHECKED AND DESIGNED BY PROFESSIONAL ENGINEER IF THE PRECAST S/C SS COMPONENT IS LARGER OR HEAVIER THAN THAT SHOWN IN FIGURE 1.

ii. FIGURE 3.5.6.3(b): Splice Sleeve Connection Details for Precast S/C SS Tower.

Figures & Tables

FIGURE 3.5.6.3(b)

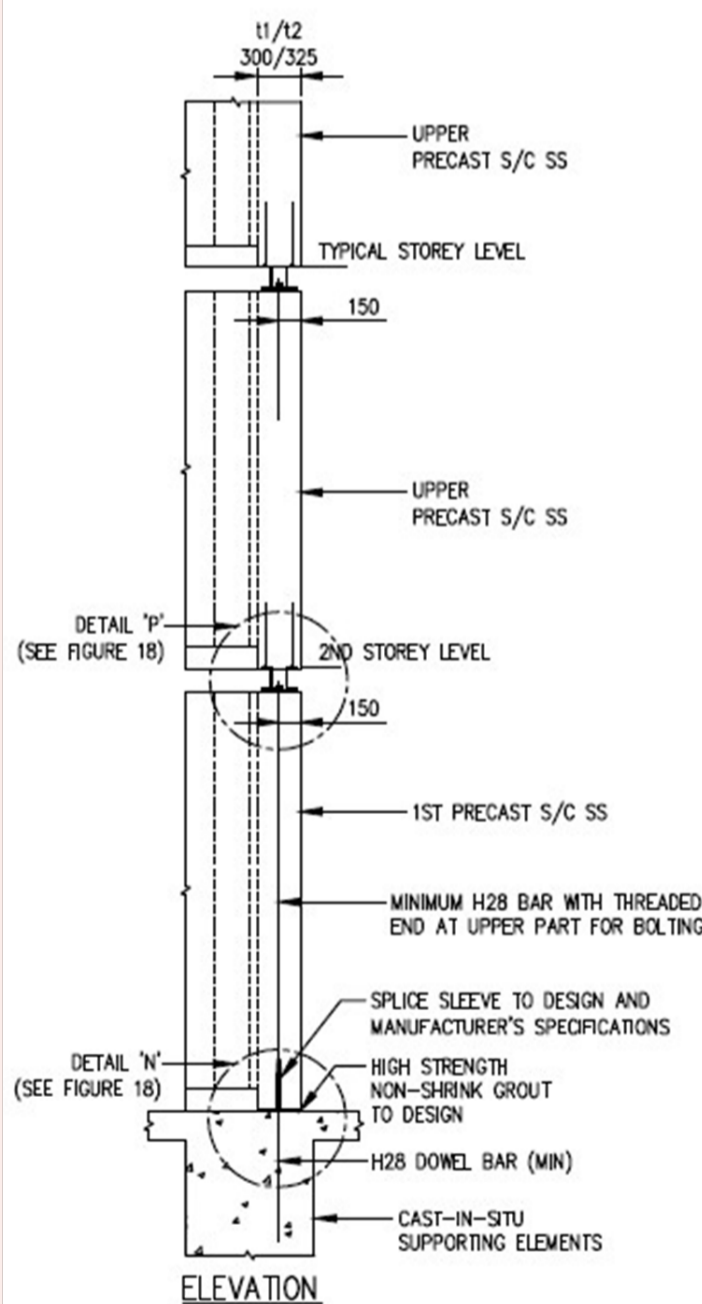

FIGURE 3.5.6.3(a): SPLICE SLEEVE CONNECTION DETAILS BETWEEN PRECAST S/C SS AND CAST IN-SITU ELEMENT AND BOLT CONNECTION DETAILS BETWEEN TWO PRECAST S/C SS

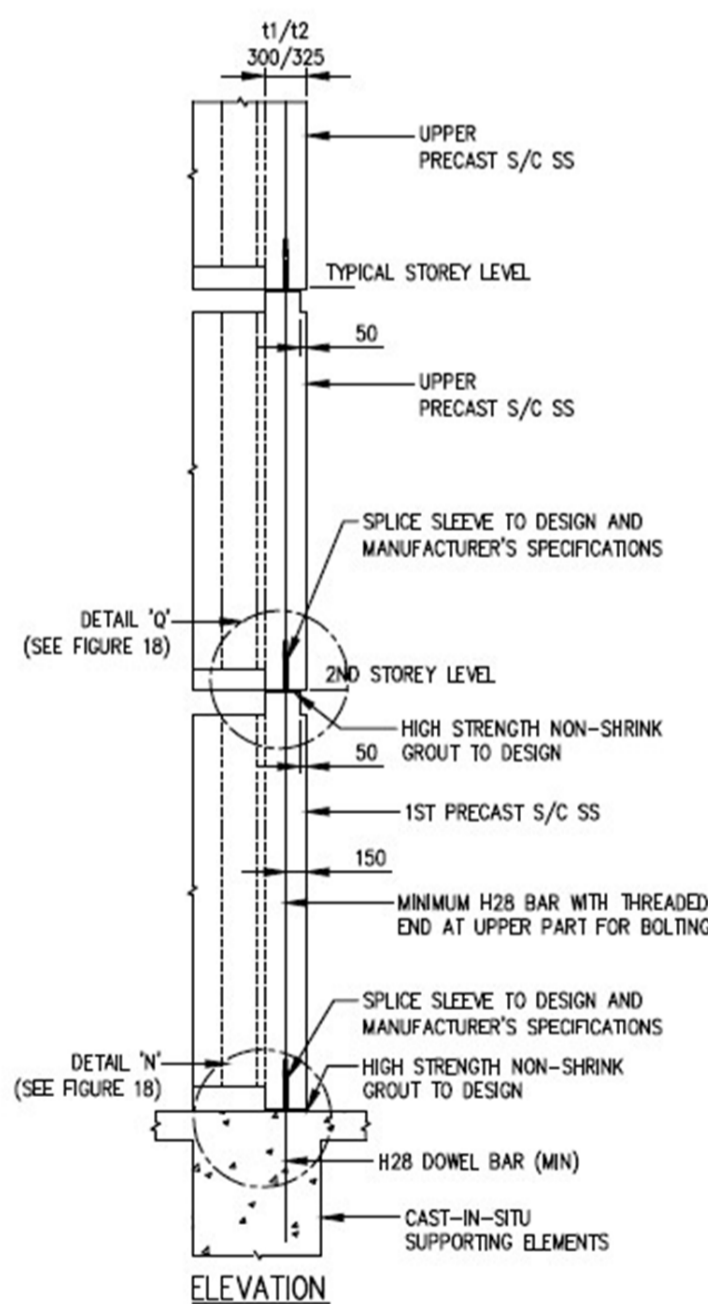
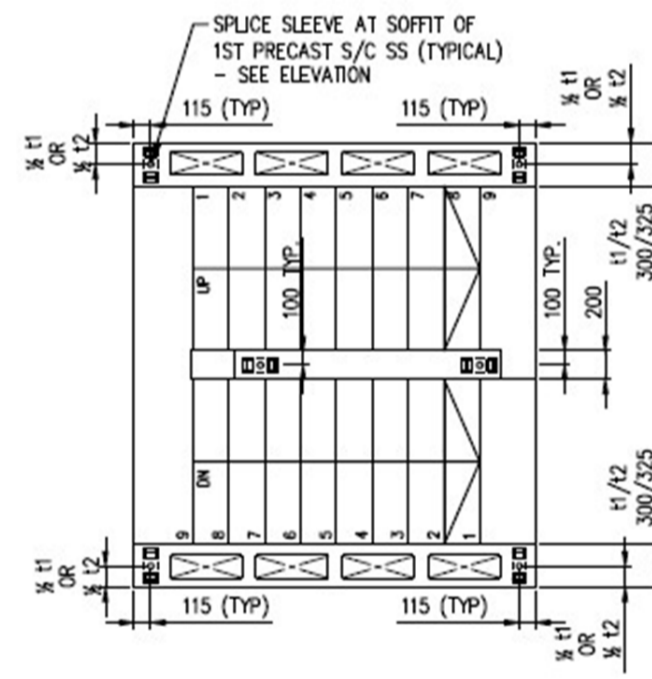
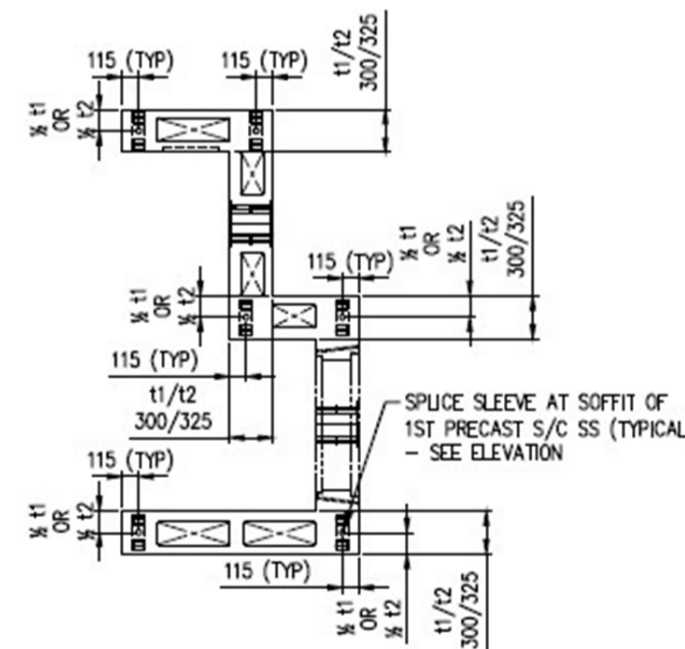

FIGURE 3.5.6.3(b): SPLICE SLEEVE CONNECTION DETAILS FOR PRECAST S/C SS TOWER



REFERENCE PLAN FOR 1ST STOREY COMPONENT 'B' PRECAST S/C SS (SIZE AND ARRANGEMENT OF CORES SHOWN IS INDICATIVE ONLY)



REFERENCE PLAN FOR 1ST STOREY COMPONENT 'C' PRECAST S/C SS (SIZE AND ARRANGEMENT OF CORES SHOWN IS INDICATIVE ONLY)

NOTES:

1. THE 1ST OR LOWEST PRECAST STOREY SHELTER MUST BE CONNECTED BY SPLICE SLEEVE (DETAIL 'N', FIGURE 18) AT 4 CORNERS OR OTHER LOCATIONS OF SHELTER WALL. MINIMUM H28 DOWEL BAR FOR SPLICE SLEEVE SHALL BE CAST IN THE CAST IN-SITU SUPPORTING ELEMENTS (WALL, COLUMN, BEAM OR FOUNDATION).
2. THE UPPER PRECAST STOREY SHELTERS SHALL BE JOINED BY BOLT AND STEEL PLATE CONNECTION (SEE FIGURE 16 FOR DETAIL 'P' AND FIGURE 18 FOR SECTION 9-9, SECTION 10-10 AND DETAIL 'P') AT THEIR 4 CORNERS OR OTHER LOCATION OF SHELTER WALL.
3. ALTERNATIVE TO THE ABOVE NOTE 2, SPLICE SLEEVE CONNECTION CAN BE USED FOR PRECAST S/C SS TOWER (SEE FIGURE 17 FOR DETAIL 'Q' AND FIGURE 18 FOR SECTION 11-11 AND DETAIL 'Q').
4. HOT ROLLED STEEL SECTION OR PLATE SHALL BE GRADE S275.
5. H28 BARS REQUIRED FOR THESE TWO TYPES OF CONNECTION SHALL BE PROPERLY SECURED IN POSITION AT 4 TOP CORNERS OR OTHER LOCATIONS OF LOWER PRECAST S/C SS WALL WITH TEMPLATE SUCH THAT THEY ARE ALIGNED WITH THE BOLT HOLES OR SPLICE SLEEVE PROVIDED AT THE BASE OF THE UPPER PRECAST STAIRCASE STOREY SHELTER.
6. THE BOLT AND STEEL PLATE CONNECTION SHALL BE CHECKED AND DESIGNED BY PROFESSIONAL ENGINEER IF THE PRECAST S/C SS COMPONENT IS LARGER OR HEAVIER THAN THAT SHOWN IN FIGURE 1.

Figures & Tables

FIGURE 3.5.6.3(a) to 3.5.6.3(c)

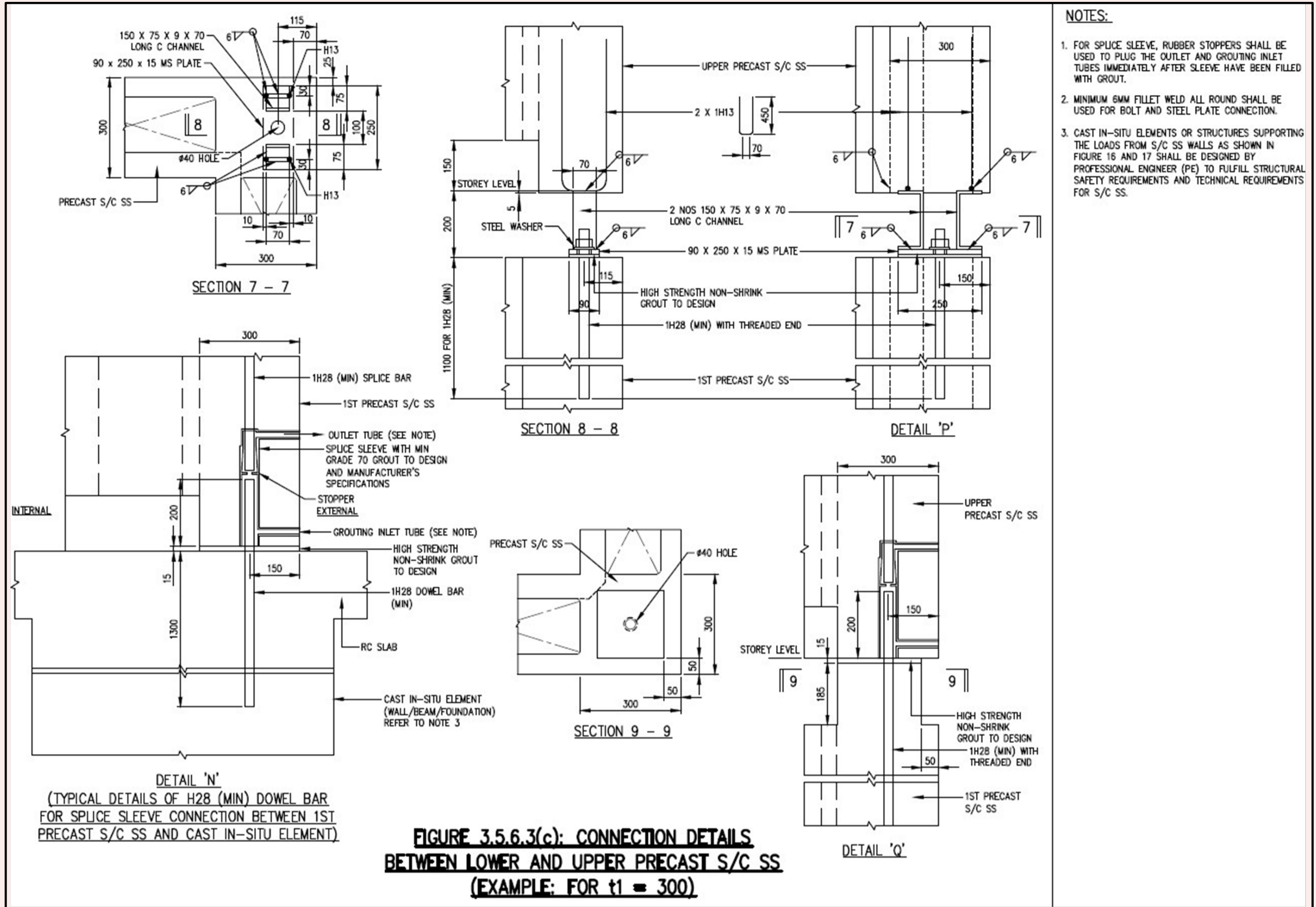

b. Where precast S/C SS is supported on cast in-situ elements (beam or wall), H28 dowel bars shall be cast in the in-situ elements for bolt and steel plate connection or splice sleeve connection between the precast S/C SS and the cast in-situ elements. These dowel bars must be properly secured in position with temporary template such that they are in line with bolt hole or splice sleeve of the upper precast S/C SS hollow core as shown in FIGURE 3.5.6.3(a) to 3.5.6.3(c). In case of the splice sleeve, it shall be pressure-grouted with minimum Grade 70 N/mm² grout to design and manufacturer's specification.

Figures & Tables

FIGURE 3.5.6.3(a) to 3.5.6.3(c)

Figures & Tables

FIGURE 3.5.6.3(a) to 3.5.6.3(c)

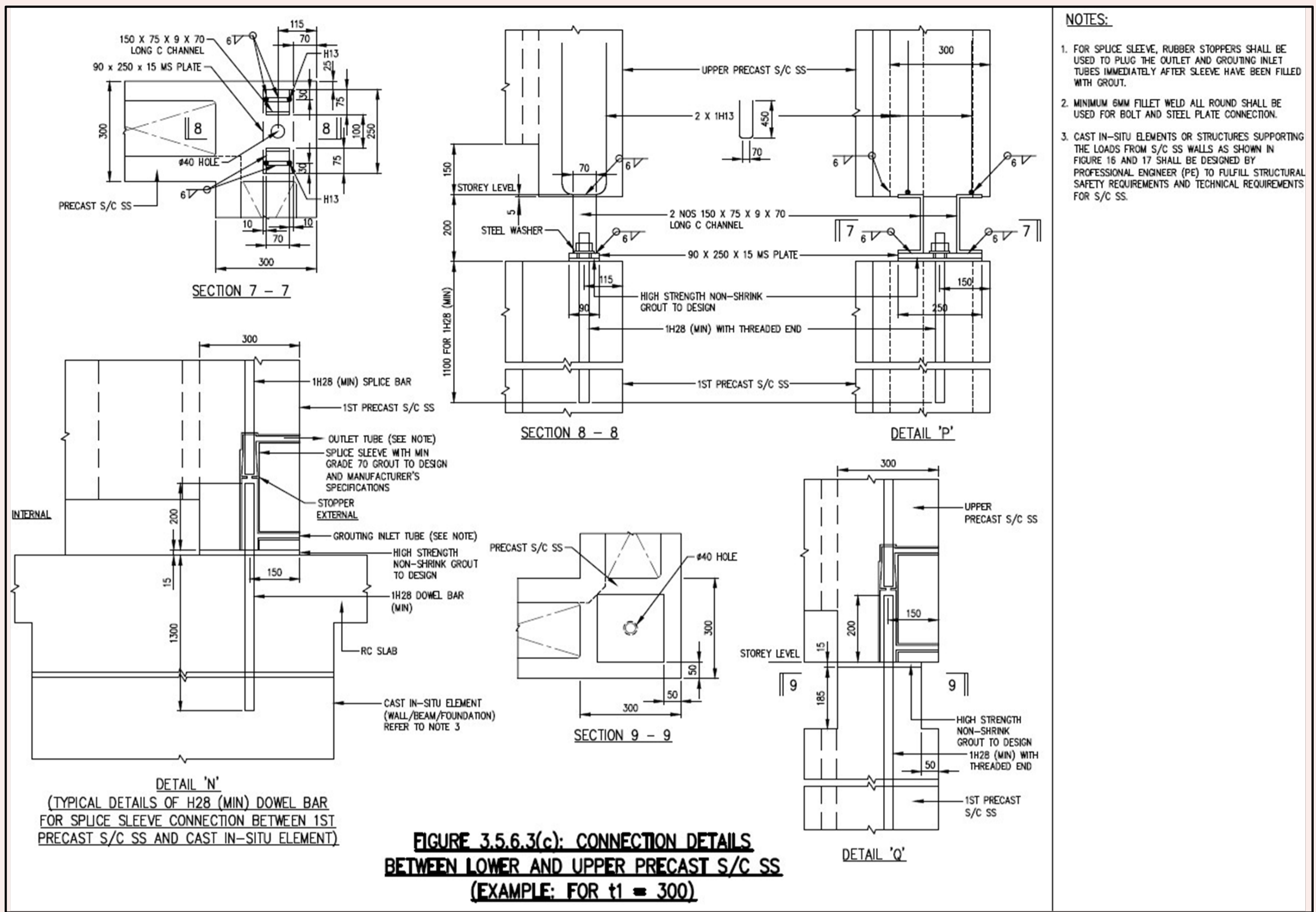

3.5.6.4 Precast Slab

- 90mm thick precast slab is cast as integrated part of the precast S/C SS component.
- The minimum reinforcements to be provided for precast slab and structural concrete topping for the slab shall be as shown in FIGURE 3.5.6.4(a). The details show the thickness of precast slab and in-situ concrete topping.

Figures & Tables

FIGURE 3.5.6.4(a)

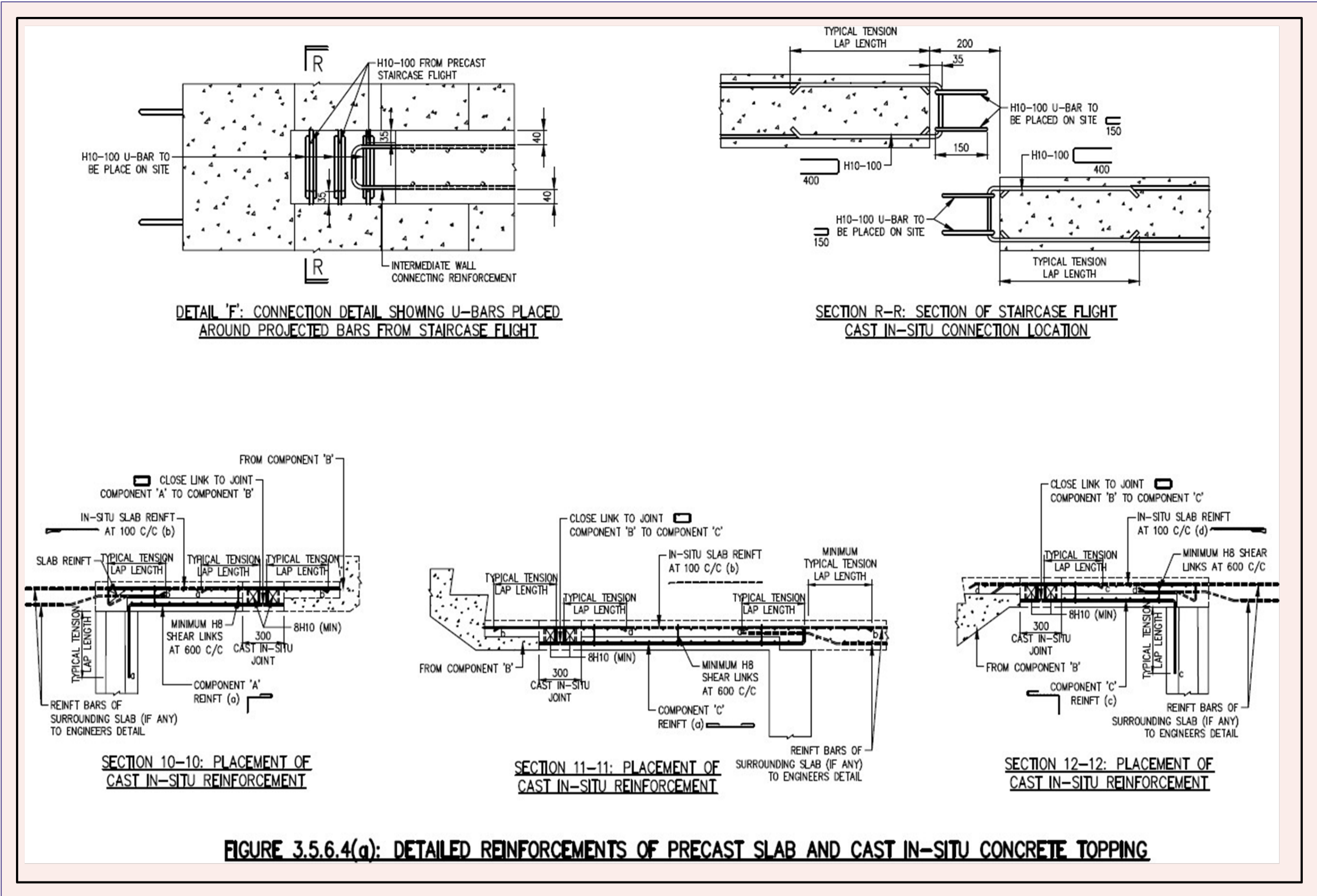

i. FIGURE 3.5.6.4(a): Detailed Reinforcements of Precast Slab and Cast In-Situ Concrete Topping.

Figures & Tables

FIGURE 3.5.6.4(a)

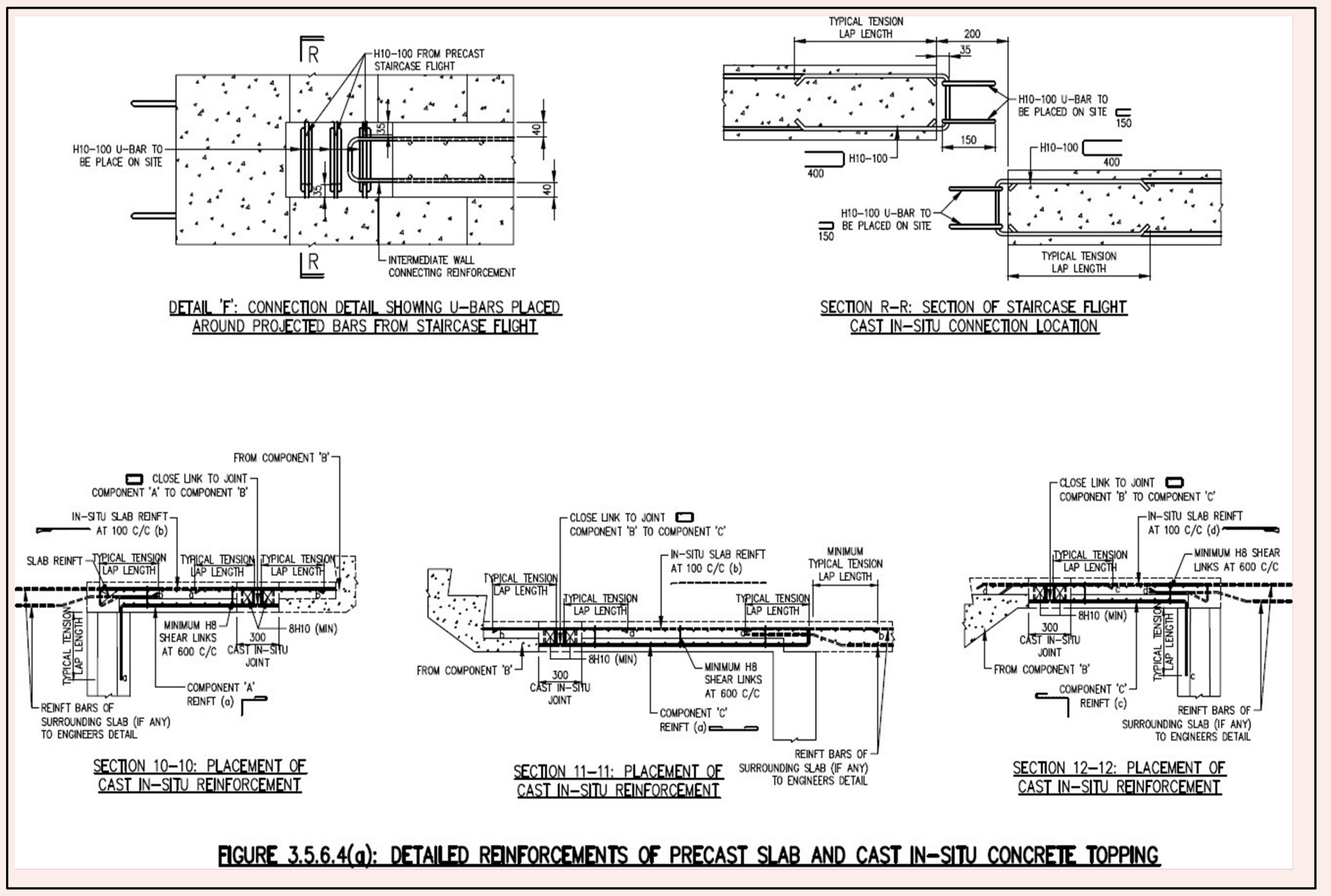

Figures & Tables

FIGURE 3.5.6.4(b)

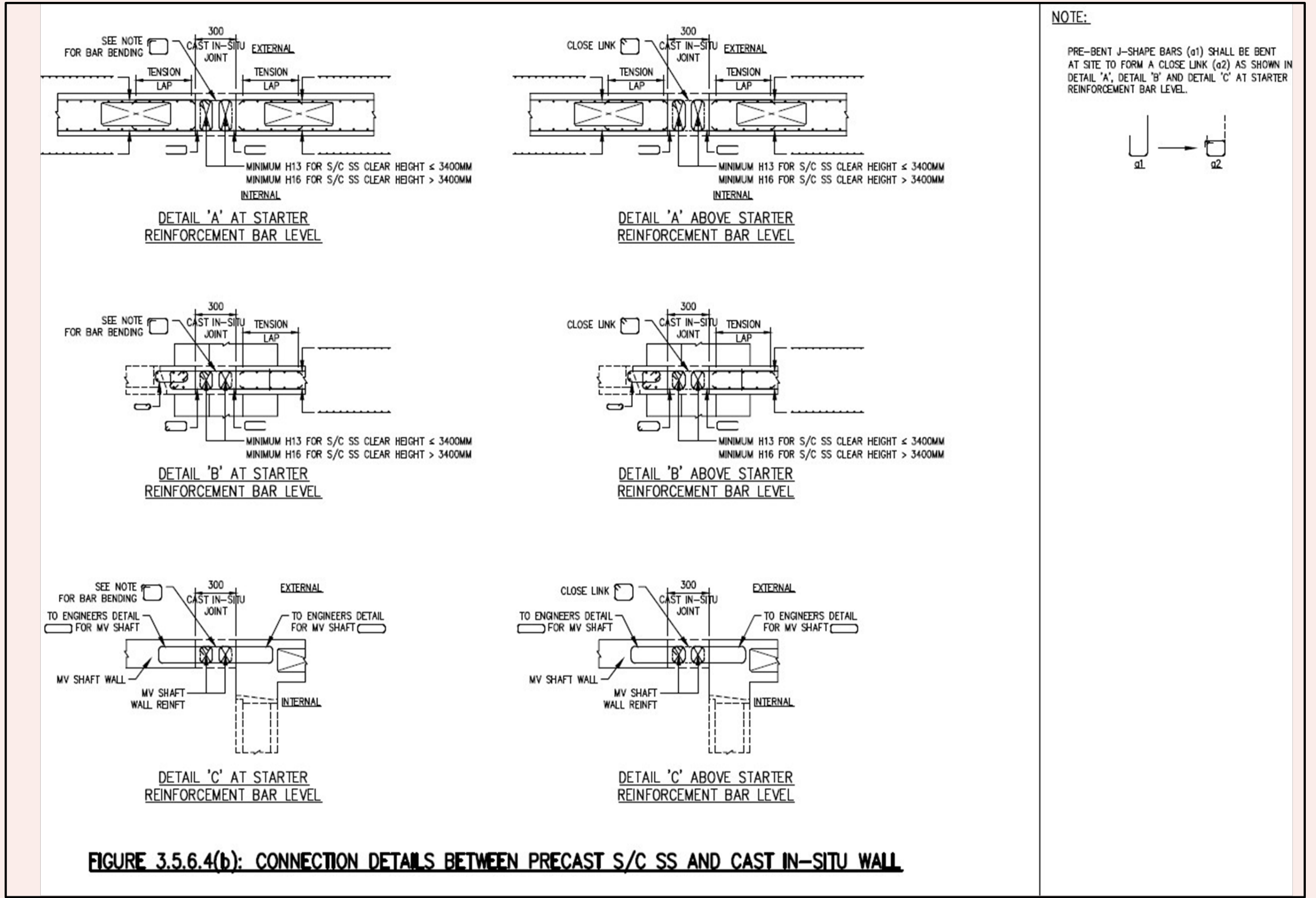

c. The shear links shall be cast in the precast slab. The hook of the shear links must be anchored around the outermost layer of reinforcement bars of the precast slab. The bend of the shear link shall be anchored around the outermost layer of reinforcement bars in the concrete topping.

3.5.6.5 External Electrical Fixtures

Where there are electrical fixtures on external face of S/C SS precast wall, a recess shall be formed on the rib of the precast S/C SS wall as shown in FIGURE 3.5.6.2(h).

Figures & Tables

FIGURE 3.5.6.2(h)

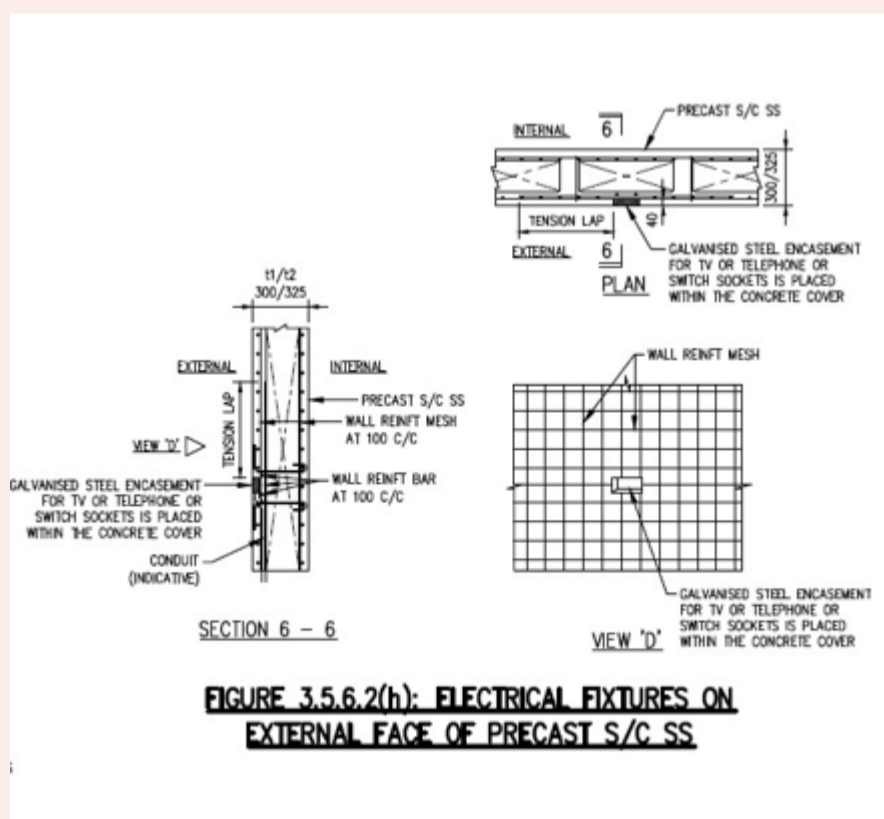

3.5.6.6 Ventilation Sleeves

One of the two ventilation sleeves shall be located above the precast S/C SS door at the entrance.

3.5.6.7 Door Recess on Precast S/C SS Wall

A recess shall be formed on the external face of the precast S/C SS wall to accommodate the S/C SS door handle when the S/C SS door is opened in 180°. The recess shall not be larger than 160mm (length) x 80mm (height) x 40mm (depth). The reinforcement bars for the recess are shown in FIGURE 3.5.6.2(g).

Figures & Tables

FIGURE 3.5.6.2(g)

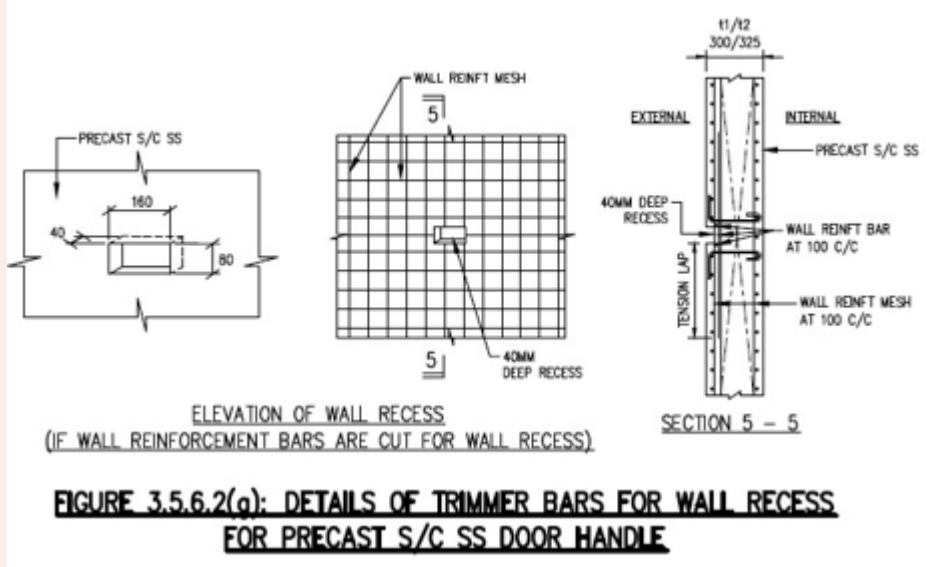

3.5.7 Joints

a. Construction joints in an SS tower shall be properly executed to ensure that the strength and the integrity of the SS are not impaired. The type and location of joints shall be specified in the design after taking into account the following:

- i. A concrete kicker, if provided, shall not be more than 100mm high.
- ii. All SS walls located within each storey shall be cast in one operation.

b. Expansion joints or contraction joints in the SS tower are not permitted.

c. Ventilation sleeve and electrical services shall not be located within connection joint between precast SS door frame and cast in-situ SS/NS wall, and within connection joint between two precast SS walls.

CLAUSE 3.6 PENETRATION OF SERVICES

3.6.1 Electrical Services

- a. All service conduits shall not penetrate directly through the walls and slabs of the SS.
- b. Only service conduits serving the SS shall embed within the SS walls and slabs. Service conduit for electrical and communication fixtures which are located on external face of SS wall may also be embedded in the SS wall. Other than these, all service conduits which do not serve the SS shall not embed within the SS wall and slab.
- c. A maximum of ten numbers of 25mm diameter service conduits for electrical and communication cables serving the SS, and for electrical and communication services which are located on external face of SS wall, are allowed to be embedded in the SS walls. Both ends of these concealed conduits shall be fully sealed with sealing material in accordance with the manufacturer's specification and up to a depth of not less than 100mm into the conduits to ensure air-tightness of the SS.
- d. Two cast-in service outlets located directly back-to-back on the internal and external faces of the SS wall are not permitted (refer to FIGURE 3.6.1(a)). Service outlets shall be fixed with at least a clear distance of 300mm between each other. Refer to FIGURE 2.10.

Figures & Tables

FIGURE 3.6.1(a): MOUNTING OF SERVICES ON EXTERNAL WALL OF A SS

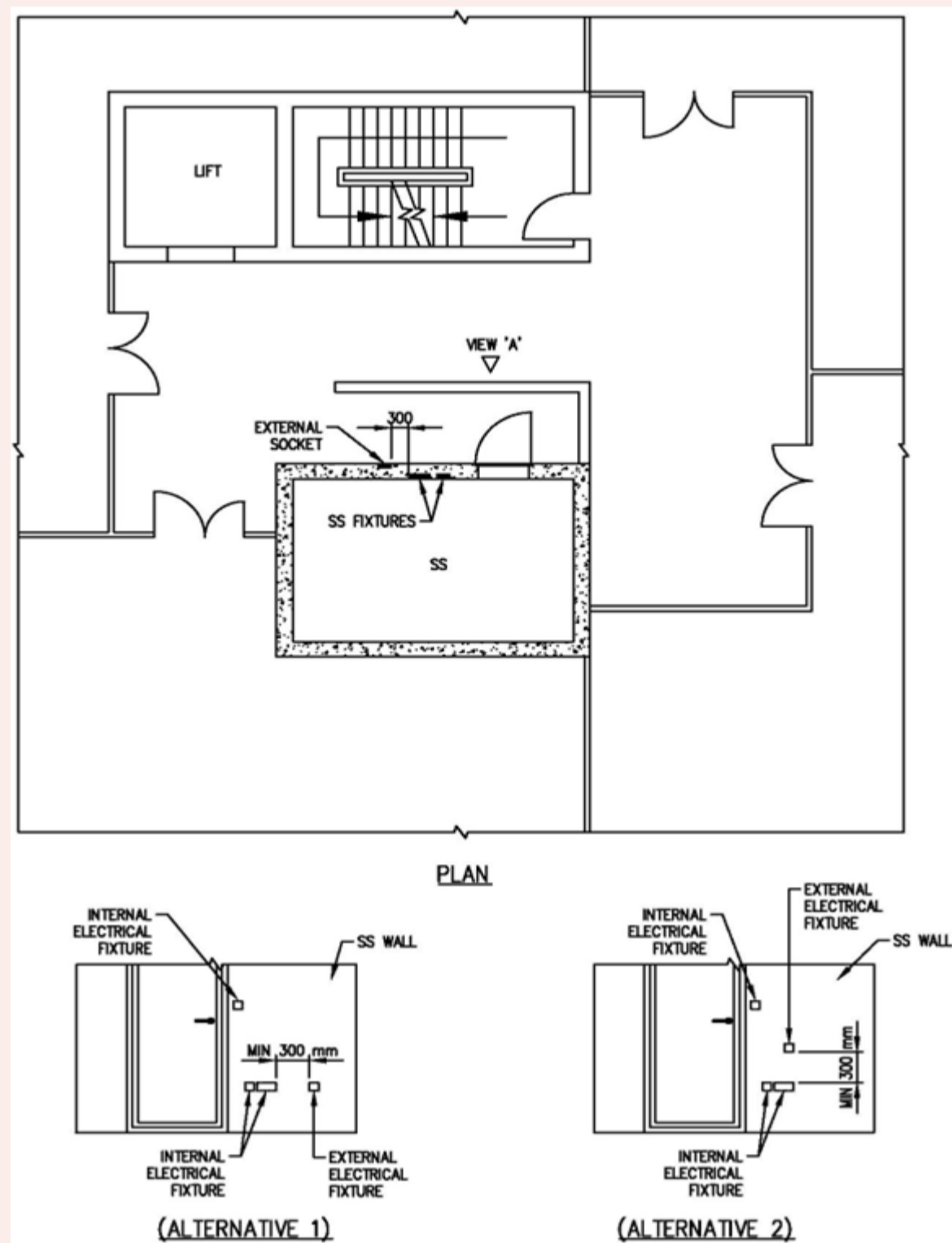

- e. Where service cables and fixtures in the SS are exposed on internal walls and slab, non-metallic inserts are to be used for their mounting. For embedded service cables and fixtures serving the SS, the details shall be as shown in FIGURE 3.5.4(e). The encasement of switch socket outlets, communication line for telephony outlet and switches of [Clause 2.6](#) shall be galvanised steel. Refer to FIGURE 3.6.1(b).

Figures & Tables

FIGURE 3.5.4(e): TYPICAL DETAILS OF EMBEDDED CONDUIT IN SS WALL

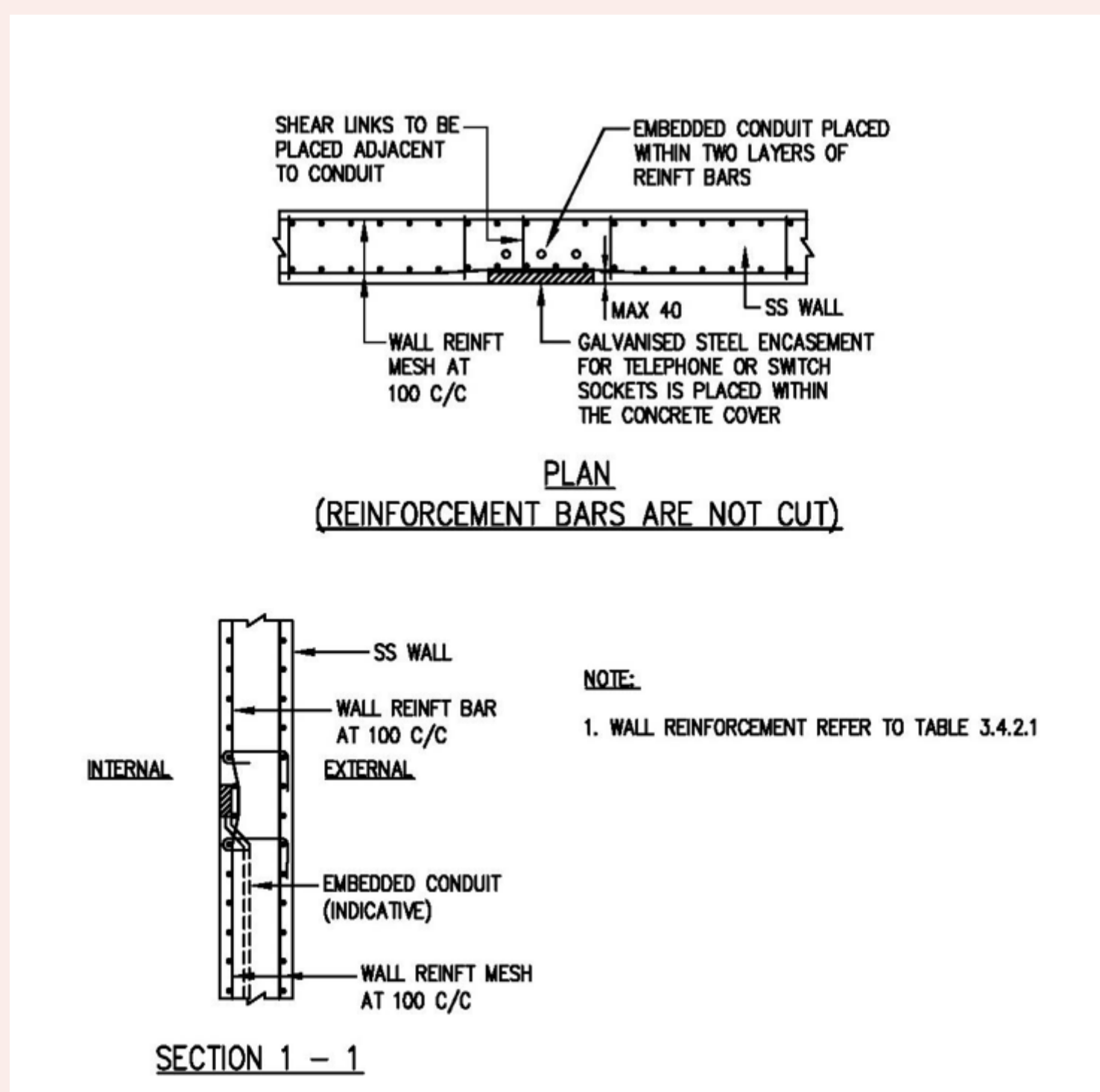
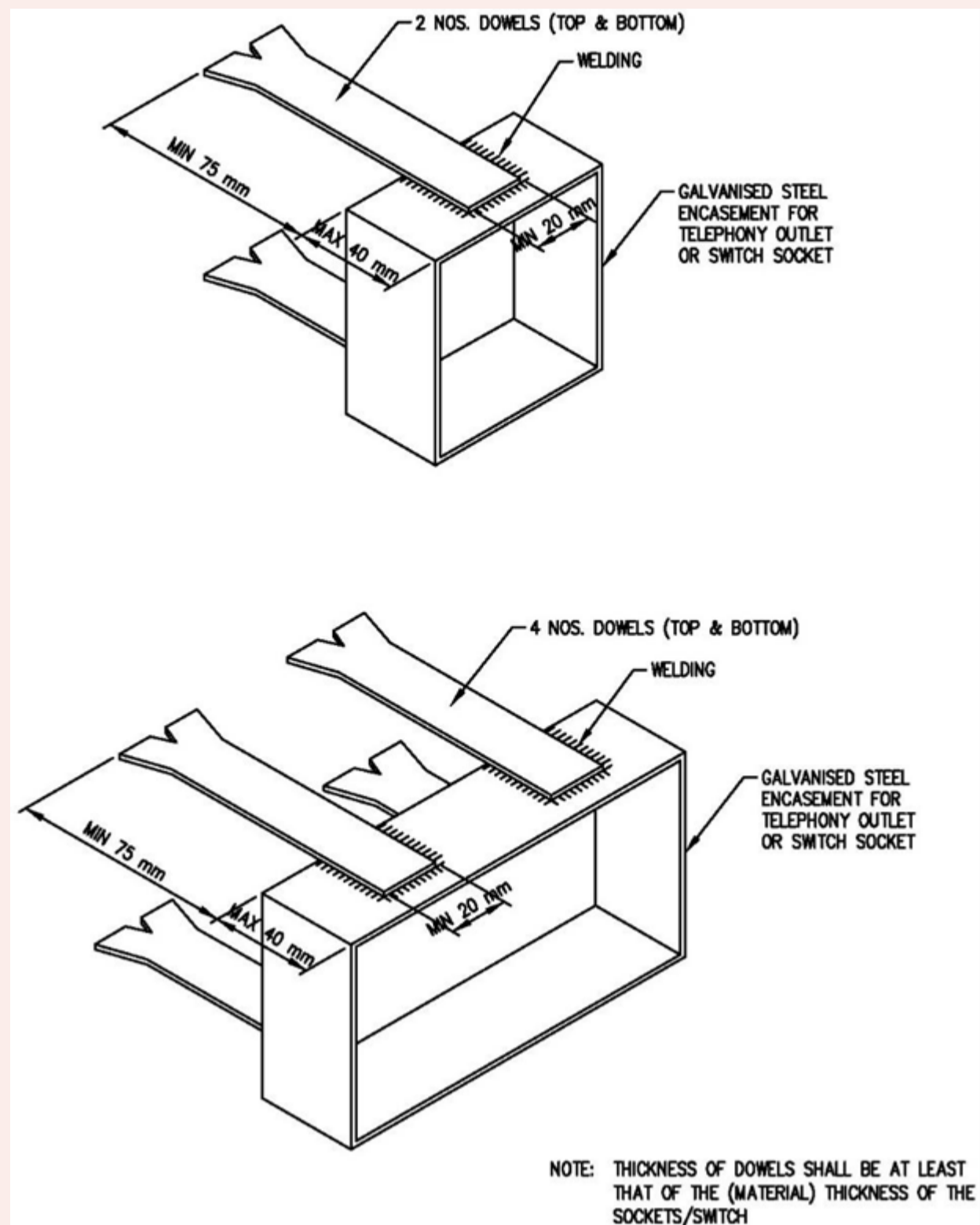

FIGURE 3.6.1(b): TYPICAL DETAILS OF EMBEDDED SOCKET/SWITCH



3.6.2 Water and Gas Services

Water and gas services are allowed to pass through the SS walls provided that they are laid within a stainless steel conduit encased by 150mm reinforced concrete all round. Refer to FIGURE 3.6.2. Joints in the pipes or in the stainless steel conduit shall be located outside the SS. Risers for services can be mounted on the external face of SS tower walls.

Figures & Tables

FIGURE 3.6.2: ENCASEMENT DETAILS OF WATER/ GAS SERVICE PIPES PENETRATING THROUGH SS WALLS

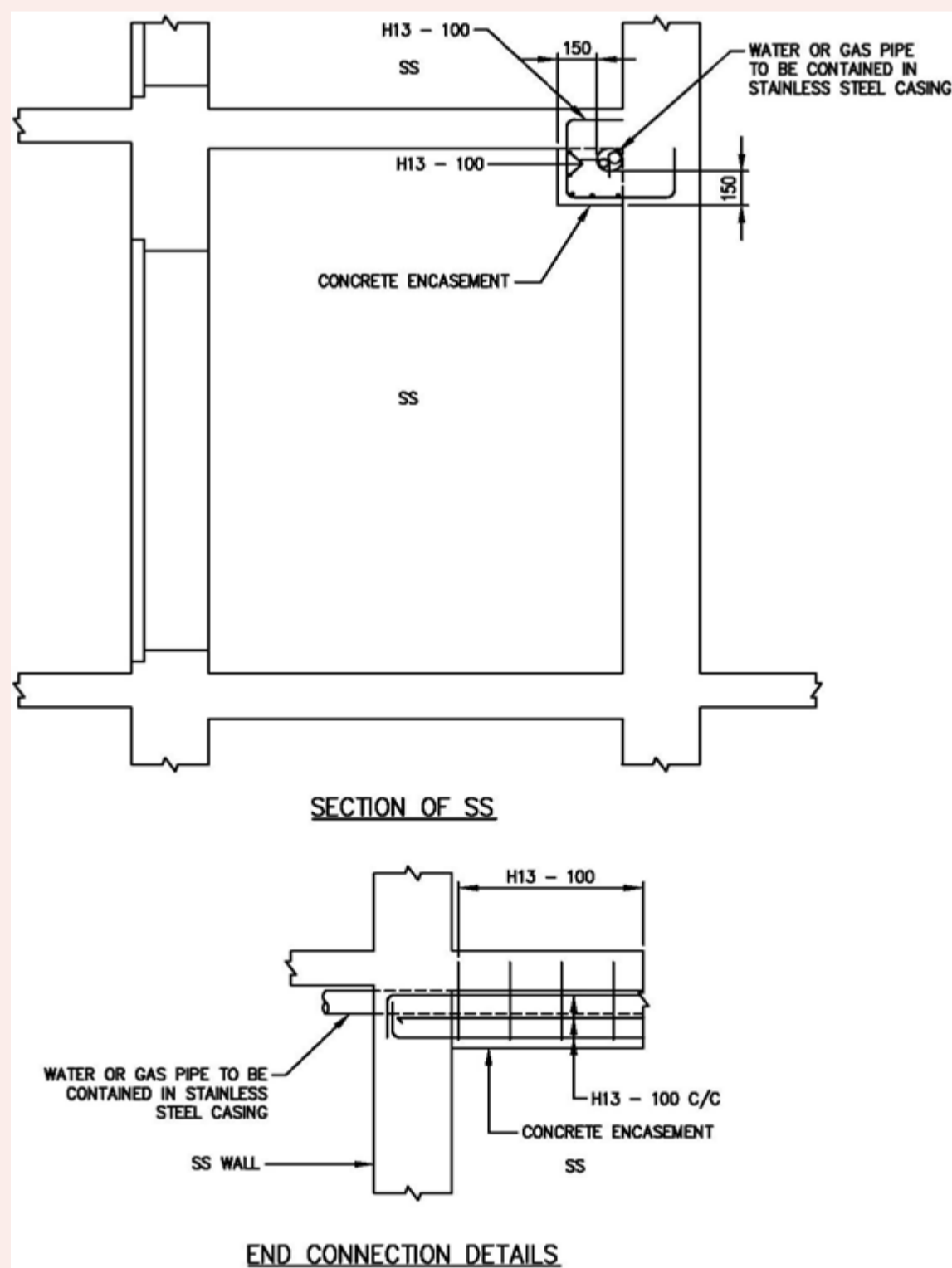

3.6.3 Refuse Chute and Gas Risers and any other service risers within setback distance of SS and S/C SS

Refuse chute and gas risers and service risers can be mounted on the external face of SS walls. Where this structure protrudes above the roof, it shall be designed with a minimum 300mm reinforced concrete all round and reinforcement details are as shown in FIGURE 3.6.3(a) to 3.6.3(c).

Figures & Tables

FIGURE 3.6.3(a): REINFORCEMENT DETAILS OF REFUSE CHUTE ABOVE ROOF LEVEL WITHIN SS SETBACK DISTANCE

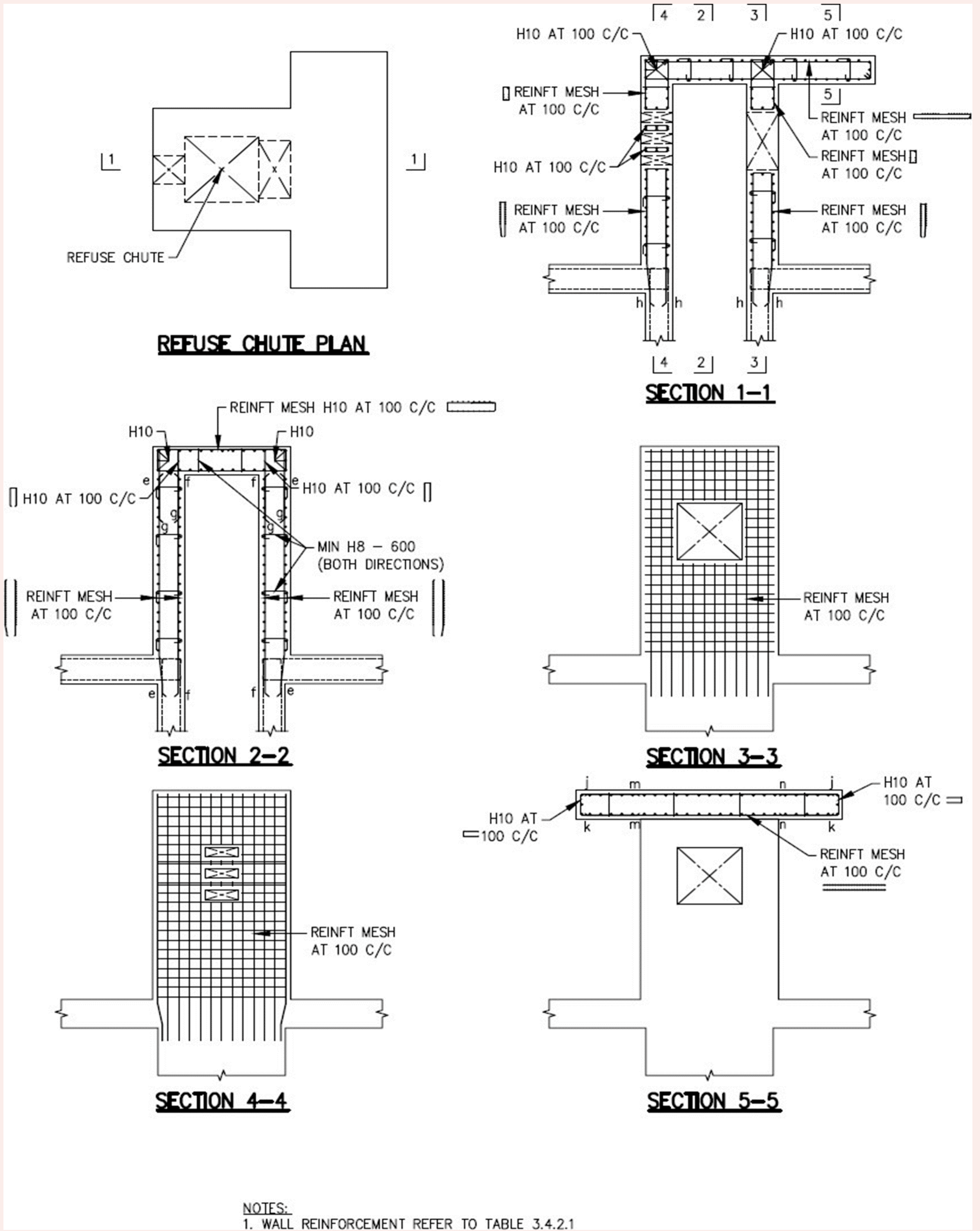
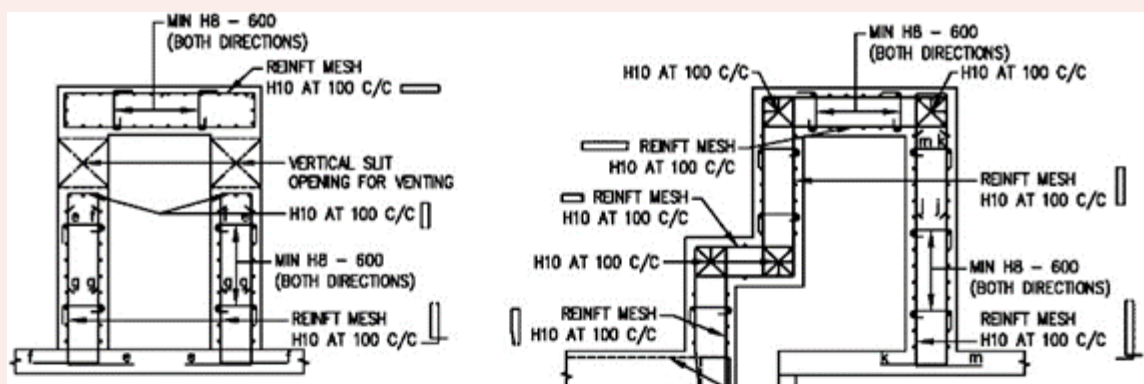
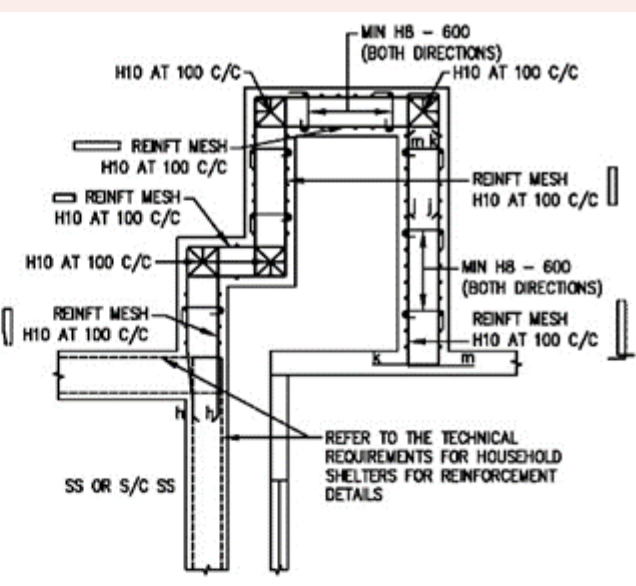

FIGURE 3.6.3(b): REINFORCEMENT DETAILS OF RC STRUCTURES ABOVE ROOF LEVEL FOR GAS RISER WITHIN SS SETBACK DISTANCE (OPENING WIDTH $\leq 100\text{MM}$)



REINFORCEMENT DETAIL OF SECTION 2A-2A OF RC PROTECTION REQUIREMENT AT ROOF LEVEL FOR PROVISION OF GAS AND WATER RISER LOCATED WITHIN SETBACK DISTANCE ENVELOP (TYPE A)



REINFORCEMENT DETAIL OF SECTION 1A-1A OF RC PROTECTION REQUIREMENT AT ROOF LEVEL FOR PROVISION OF GAS AND WATER RISER LOCATED WITHIN SETBACK DISTANCE ENVELOP (TYPE A)

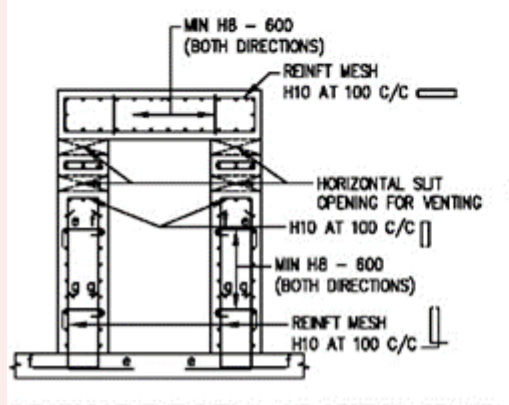

REINFORCEMENT DETAIL OF SECTION 2B-2B OF RC PROTECTION REQUIREMENT AT ROOF LEVEL FOR PROVISION OF GAS AND WATER RISER LOCATED WITHIN SETBACK DISTANCE ENVELOP (TYPE B)

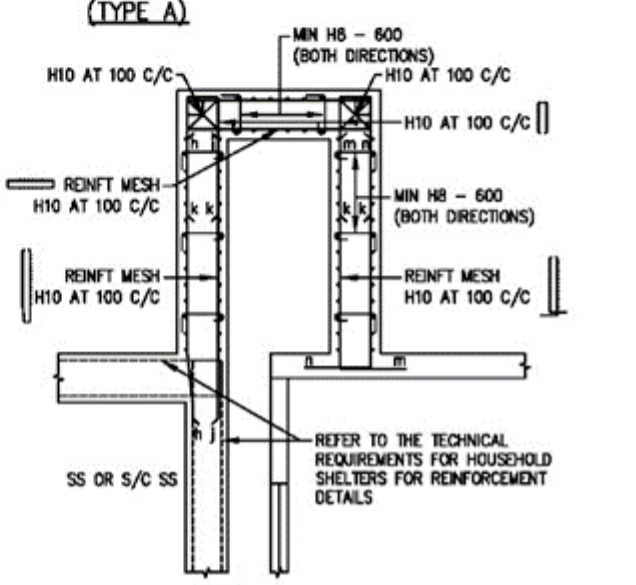

REINFORCEMENT DETAIL OF SECTION 1B-1B OF RC PROTECTION REQUIREMENT AT ROOF LEVEL FOR PROVISION OF GAS AND WATER RISER LOCATED WITHIN SETBACK DISTANCE ENVELOP (TYPE B)

NOTE:
1. WALL REINFORCEMENT REFER TO TABLE 3.4.2.1

FIGURE 3.6.3(c): REINFORCEMENT DETAILS OF RC STRUCTURES ABOVE ROOF LEVEL FOR ANY OTHER SERVICE RISER WITHIN SS SETBACK DISTANCE (OPENING WIDTH ≤ 100MM)

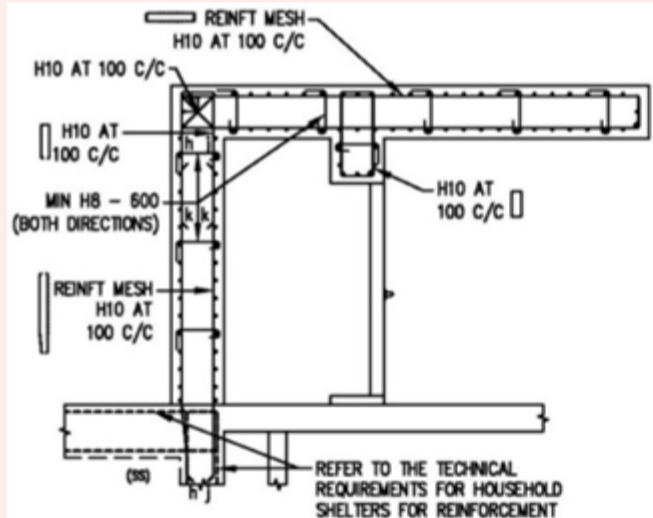

REINFORCEMENT DETAIL OF SECTION 1C-1C OF RC PROTECTION REQUIREMENT AT ROOF LEVEL FOR PROVISION OF ANY OTHER SERVICE RISER LOCATED WITHIN SETBACK DISTANCE ENVELOP

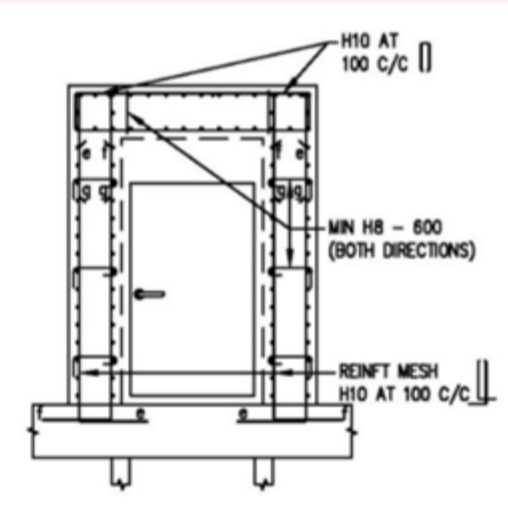

REINFORCEMENT DETAIL OF SECTION 3C-3C OF RC PROTECTION REQUIREMENT AT ROOF LEVEL FOR PROVISION OF ANY OTHER SERVICE RISER LOCATED WITHIN SETBACK DISTANCE ENVELOP

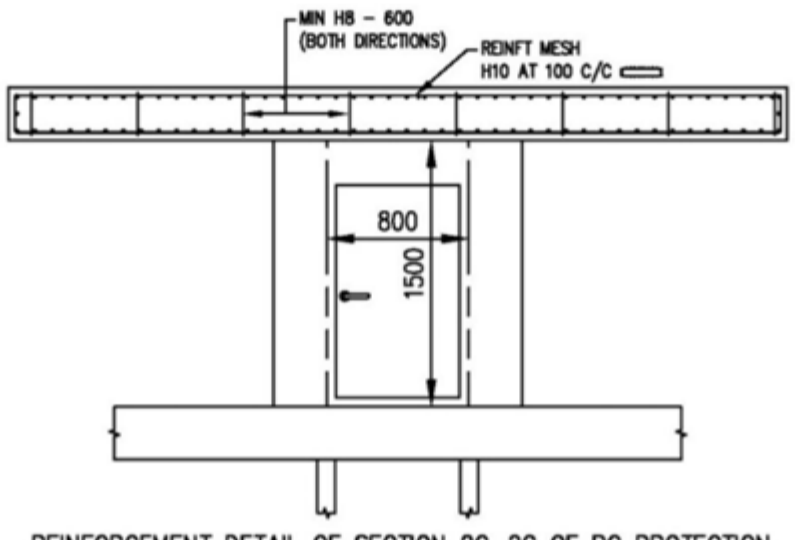

REINFORCEMENT DETAIL OF SECTION 2C-2C OF RC PROTECTION REQUIREMENT AT ROOF LEVEL FOR PROVISION OF ANY OTHER SERVICE RISER LOCATED WITHIN SETBACK DISTANCE ENVELOP

NOTE:
1. WALL REINFORCEMENT REFER TO TABLE 3.4.2.1

Clause No.	Amendment Date	Effective Date	Clause Status	Clause Before Amendment	Circular Date
------------	----------------	----------------	---------------	-------------------------	---------------

CLAUSE 4.1 GENERAL

Two 150mm diameter ventilation sleeves shall be cast into the wall/s of each SS. In the case of S/C SS or scissor S/C SS, no fire rating is required for these fragmentation plates. The two ventilation sleeves shall be provided in the S/C SS or scissor S/C SS wall at the staircase entrance landing or intermediate landing at each storey or one each at the entrance landing and intermediate landing. Only ventilation sleeves of an approved design from approved suppliers shall be used.

CLAUSE 4.2 POSITION

The position of each ventilation sleeve opening shall comply with the below clauses. Refer to FIGURE 4.2(a) and 4.2(b).

- The height of each ventilation sleeve opening, measured from the centre of the opening to internal FFL of the SS shall be between 1900mm and 3550mm.
- The ventilation sleeve opening shall be positioned such that there is sufficient clearance from any structural elements and services. The centre of the ventilation sleeve opening to the soffit of ceiling slab and the nearest face of the internal SS walls shall be at least 350mm.

Figures & Tables

FIGURE 4.2(a): POSITION OF VENTILATION SLEEVES

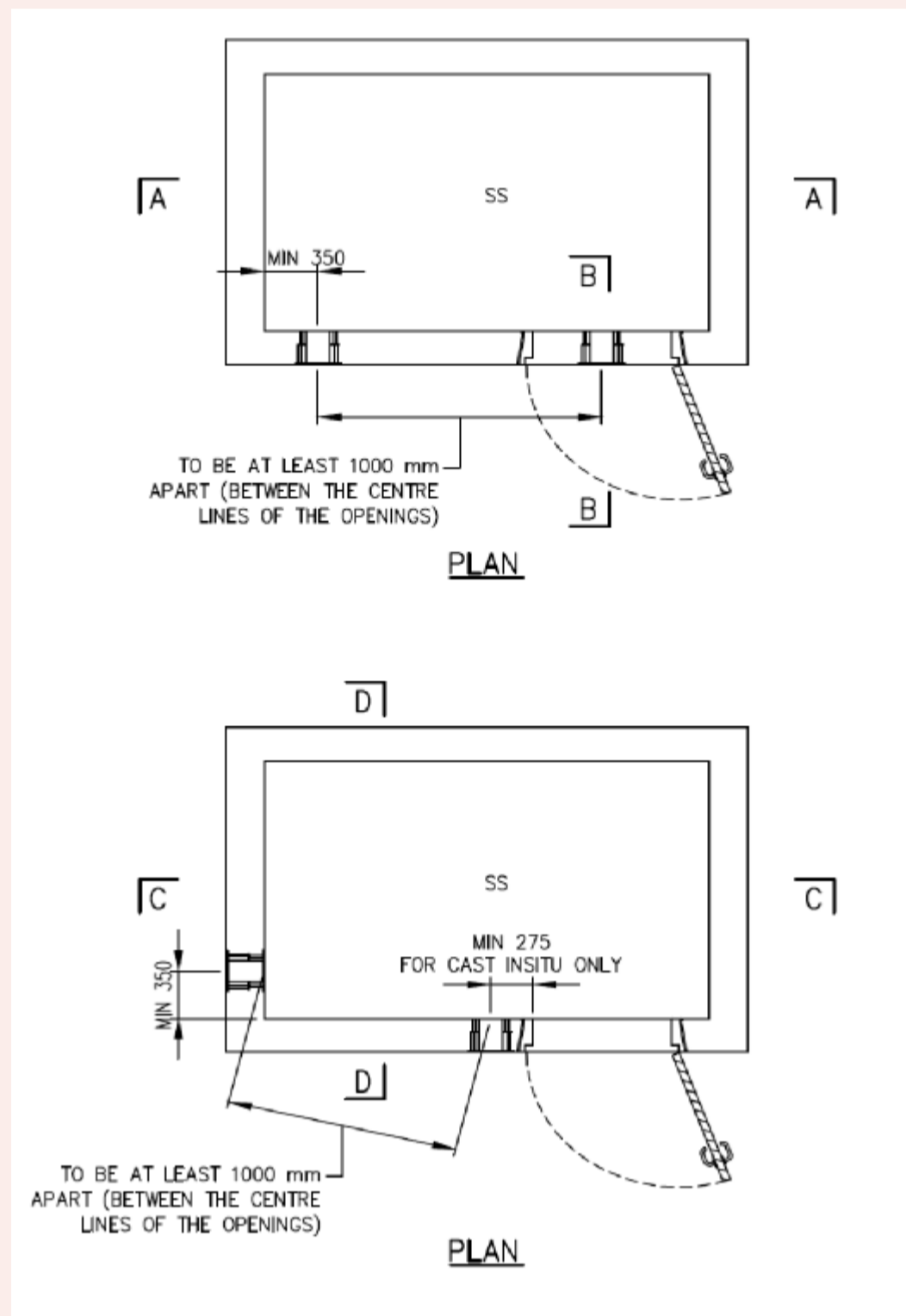
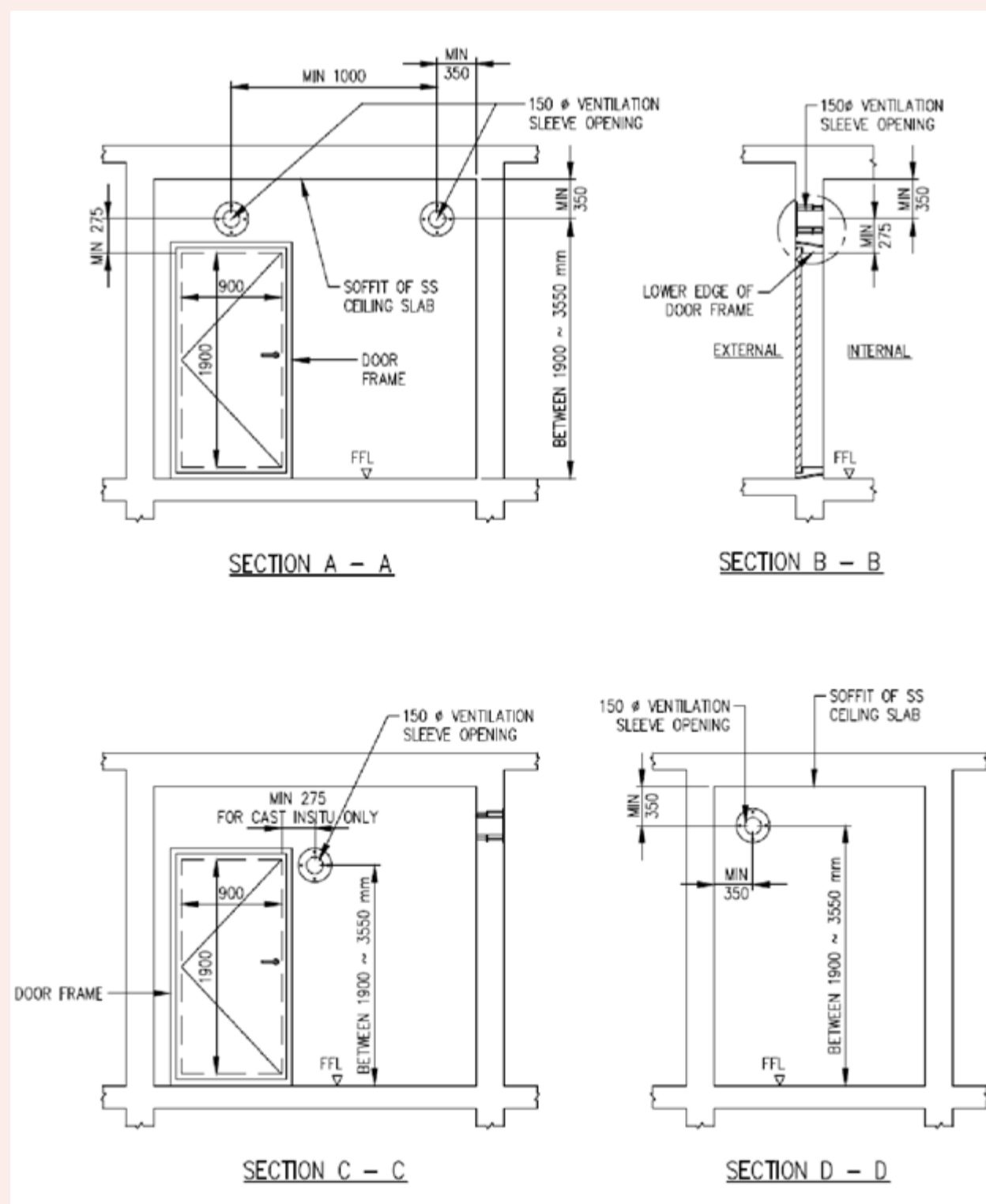

FIGURE 4.2(b): SECTIONAL VIEWS OF VENTILATION SLEEVES



- Where the ventilation sleeve is placed above or adjacent to the SS door frame, the centre of the ventilation sleeve opening shall be at least 275mm from the nearest edge of the SS door frame.
- The minimum distance between the centres of the two ventilation sleeves openings shall be at least 1000mm.
- Where the ventilation sleeve is located along the staircase flight of the S/C SS or scissor S/C SS, the maximum distance measuring between the edge of either end of staircase flight and the centre of the ventilation sleeve opening shall be 500mm.
- The ventilation sleeve openings shall not be opened into enclosed area outside the SS or S/C SS or scissor S/C SS. The ventilation sleeves shall not be located in the SS wall sharing with the dwelling unit. Refer to FIGURE 4.2(c). Enclosed area shall be defined as an area fully surrounded walls with an access door.

Figures & Tables

FIGURE 4.2(c): LOCATION OF VENTILATION SLEEVES

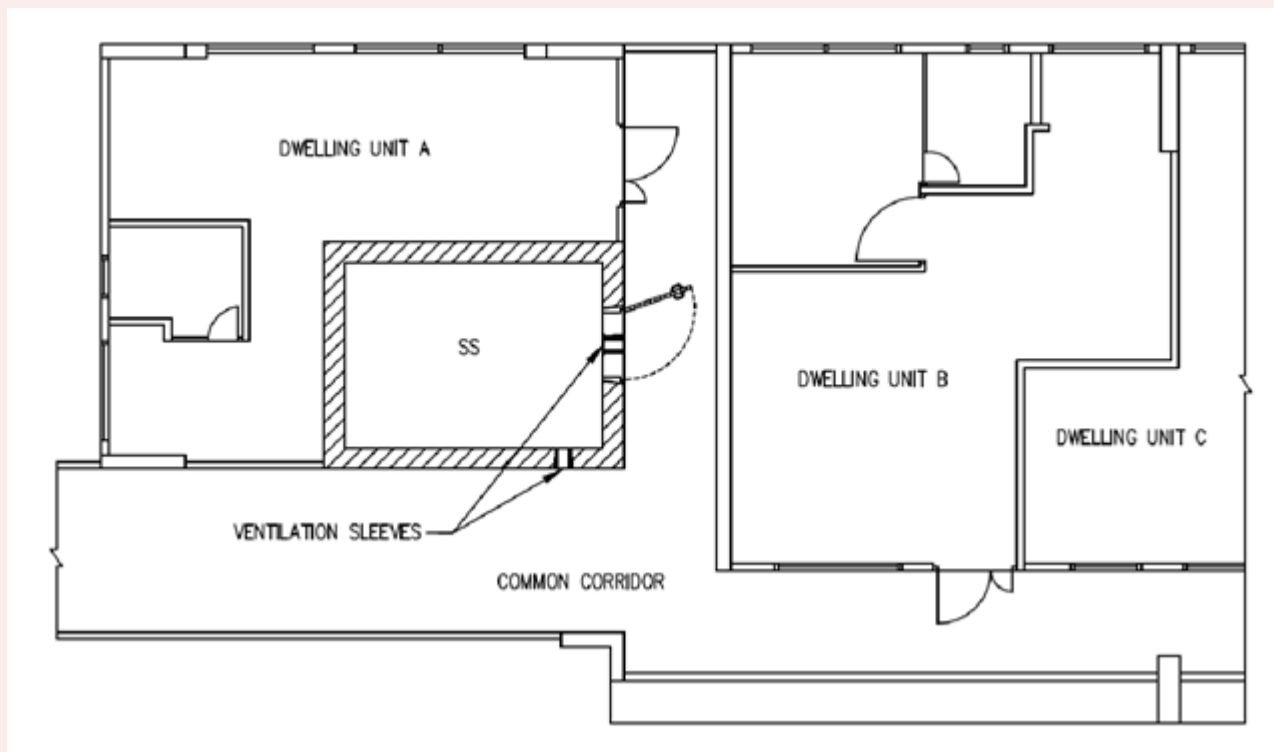

g. In the case of SS, the ventilation sleeve shall be located away from the rescue hatch openings. Refer to FIGURE 2.6.1(a).

Figures & Tables

FIGURE 2.6.1(a): SPECIFIC SS FIXTURE AND OPENINGS

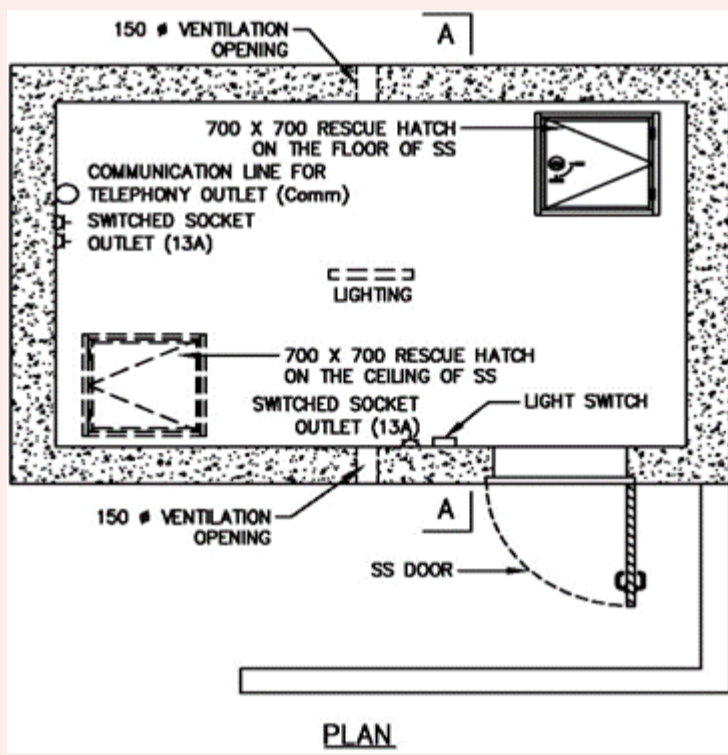

CLAUSE 4.3 ACCESSIBILITY OF VENTILATION SLEEVES

4.3.1 Clearance in front of and around Fragmentation Plates

a. The minimum clearance from the fragmentation plate to RC beam or structure or service shall be 50mm. Where the RC beam or structure or service is fronting the fragmentation plate of ventilation sleeve, the clear distance between them shall be at least 500mm. Refer to FIGURE 4.3.1(a).

Figures & Tables

FIGURE 4.3.1(a): MINIMUM CLEARANCE FOR FRAGMENTATION PLATE

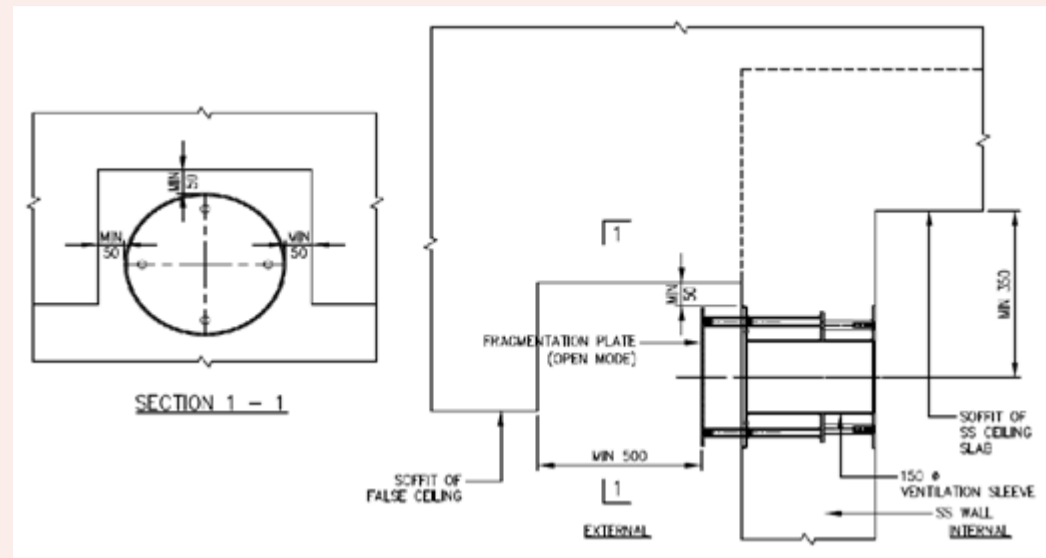

b. In addition, there shall be a minimum unobstructed distance of at least 700mm from the face of the VS openings to the nearest face of any other internal structural elements within the SS, e.g. any protruding parts of a staircase. Refer to FIGURE 4.3.1(b).

Figures & Tables

FIGURE 4.3.1(b): MINIMUM CLEARANCE FROM INTERNAL FACE OF VENTILATION SLEEVE

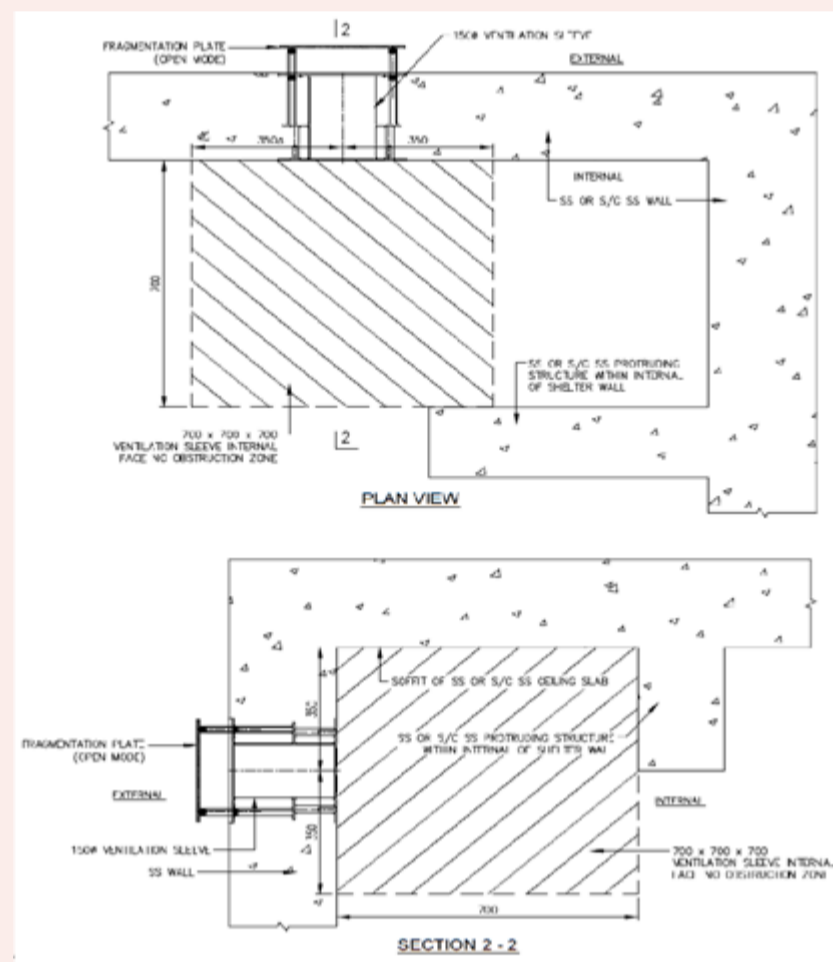

4.3.2 False Ceiling below Ventilation Sleeves

Where false ceilings are provided outside the SS, S/C SS or scissor S/C SS and below the ventilation sleeves, there shall be one access panel of a minimum size of 600mm x 600mm positioned directly below each ventilation sleeve. In the case of SS, one of the access panels shall be perforated and the ventilation sleeve above it shall be left open during peacetime. Refer to FIGURE 4.3.2.

Figures & Tables

FIGURE 4.3.2: PERFORATED ACCESS PANEL BELOW VENTILATION SLEEVE

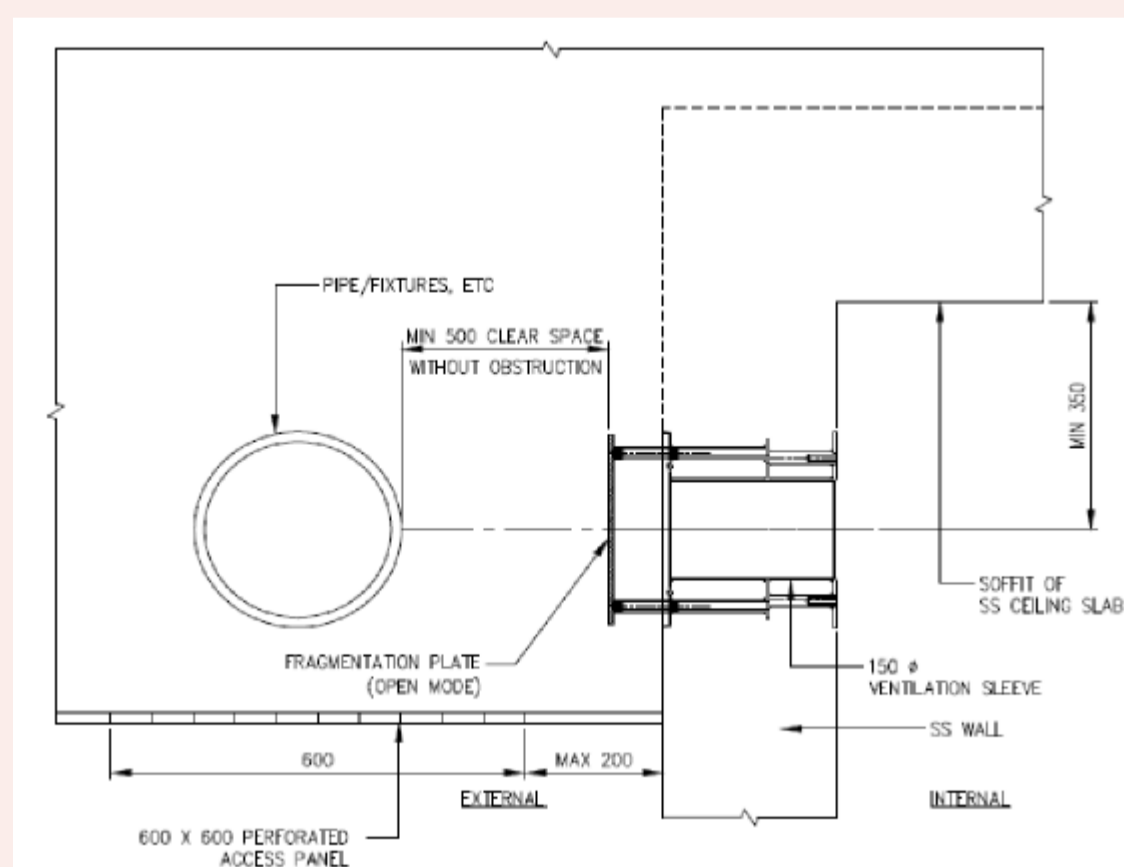

CLAUSE 4.4 FRAGMENTATION PLATE

Each ventilation sleeve shall have a 10mm thick stainless steel fragmentation plate mounted on the external face using 12mm stainless steel bolts. There shall be no drilling of additional holes on the fragmentation plates. Refer to FIGURE 4.4.

Figures & Tables

FIGURE 4.4: DETAILS OF VENTILATION SLEEVE AND FRAGMENTATION PLATE

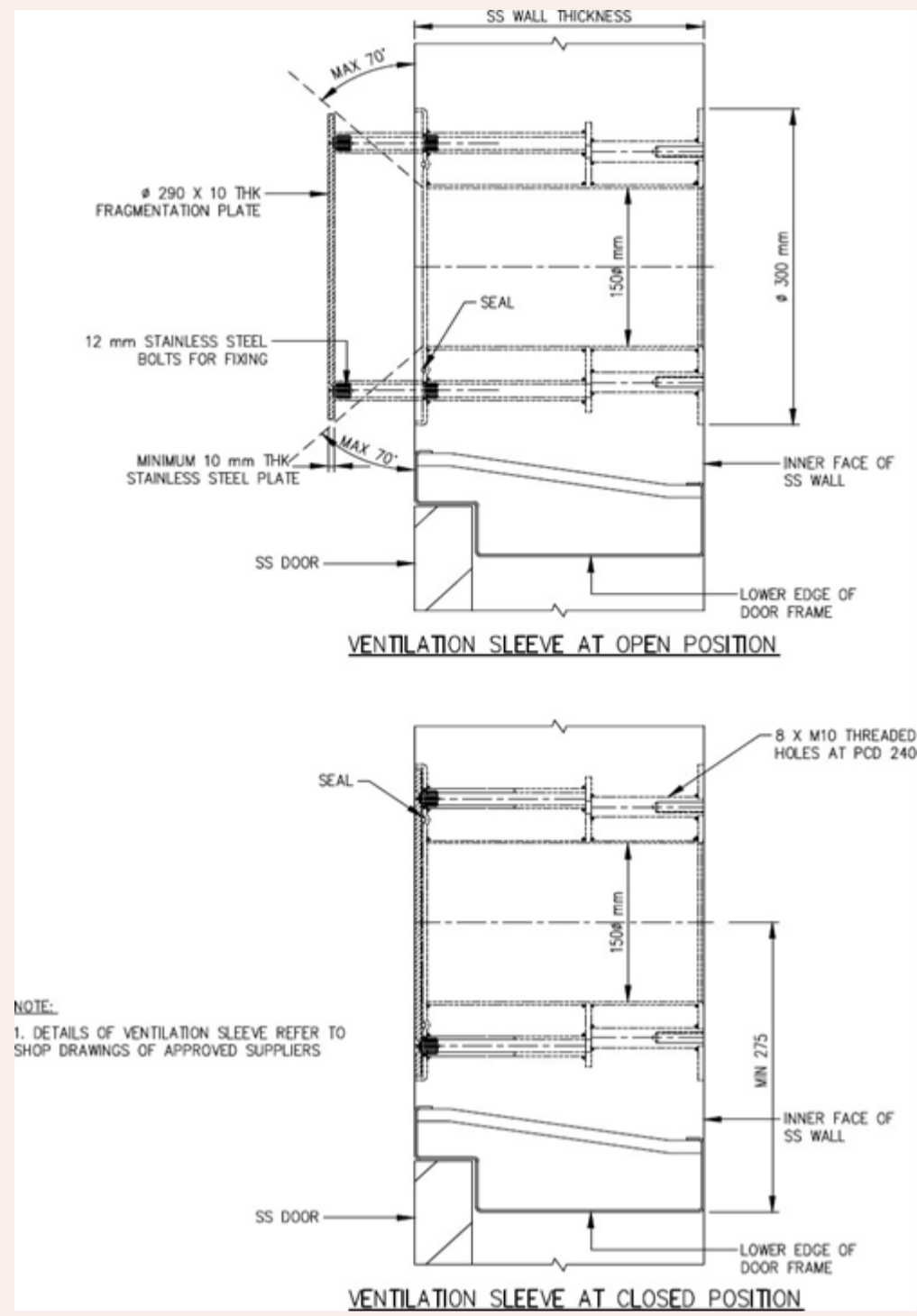

Clause No.	Amendment Date	Effective Date	Clause Status	Clause Before Amendment	Circular Date
------------	----------------	----------------	---------------	-------------------------	---------------

CLAUSE 5.1 GENERAL

The SS door shall provide an airtight closure to the SS. The SS door providing entry into the SS from the outside shall be designed to open outwards from the SS.

SS Door frame that is cast together with the SS wall shall have single or double door rebate. Refer to Figure 2.5.1(a) and 2.5.1(b).

Figures & Tables

FIGURE 2.5.1(a): SS DOOR FRAME WITH SINGLE DOOR REBATE

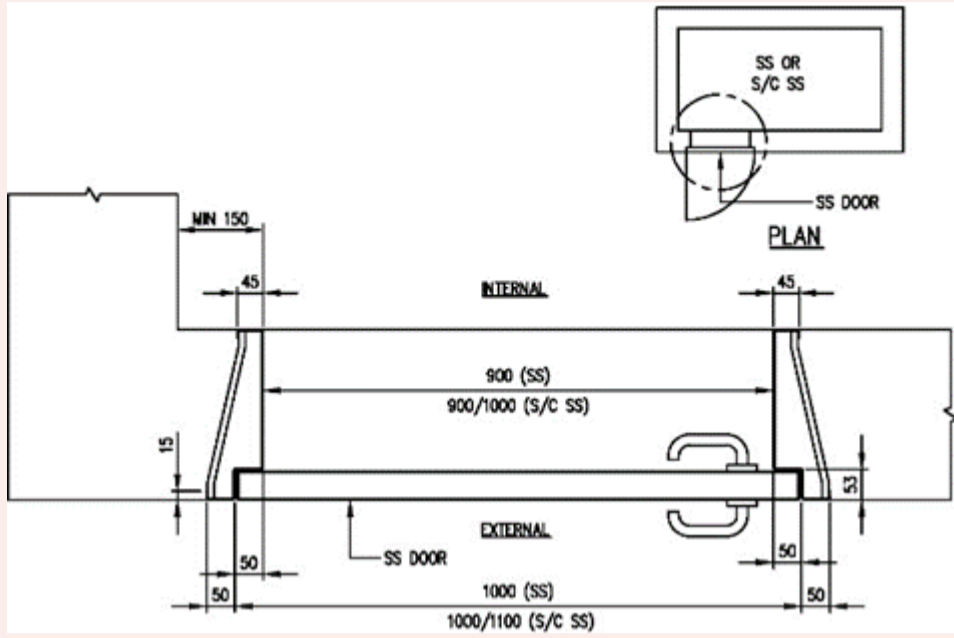
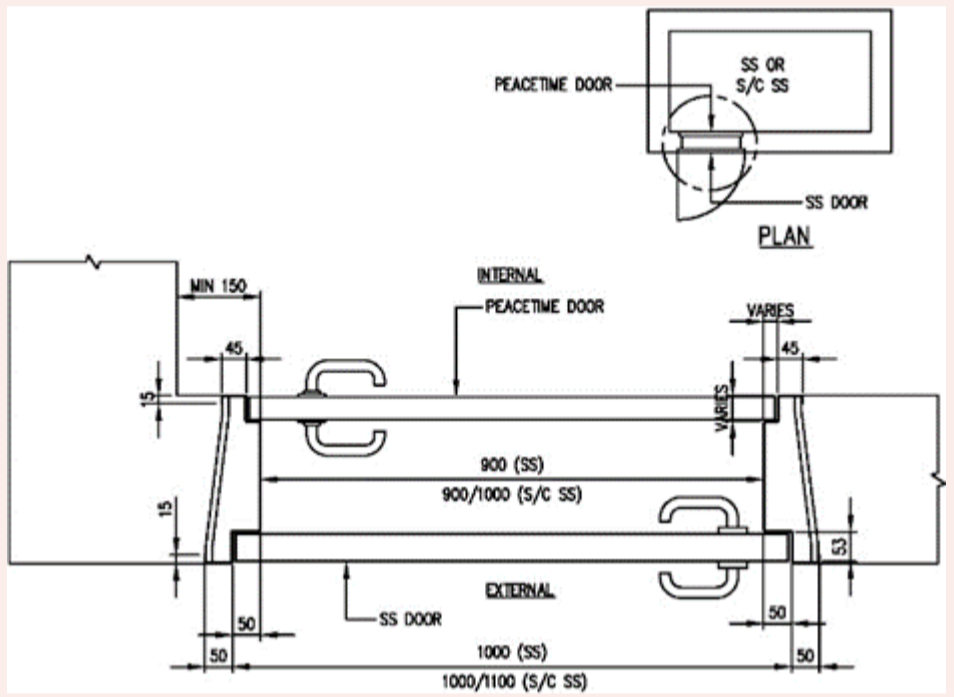

FIGURE 2.5.1(b): SS DOOR FRAME WITH DOUBLE DOOR REBATES



CLAUSE 5.2 APPROVED SS DOOR

Only SS doors of an approved design from an approved supplier, and which have been certified and listed under the Product Listing Scheme with a valid Certificate of Conformity (CoC) (as stipulated in [Chapter 8](#) of this TR), shall be used.

CLAUSE 5.3 REMOVABLE DOOR KERB - APPLICABLE FOR S/C SS AND SCISSOR S/C SS ONLY

The removable SS door kerb shall be mounted on the top part of SS door frame during peacetime. Refer to FIGURE 5.3.

Figures & Tables

FIGURE 5.3: MOUNTING OF REMOVABLE KERB

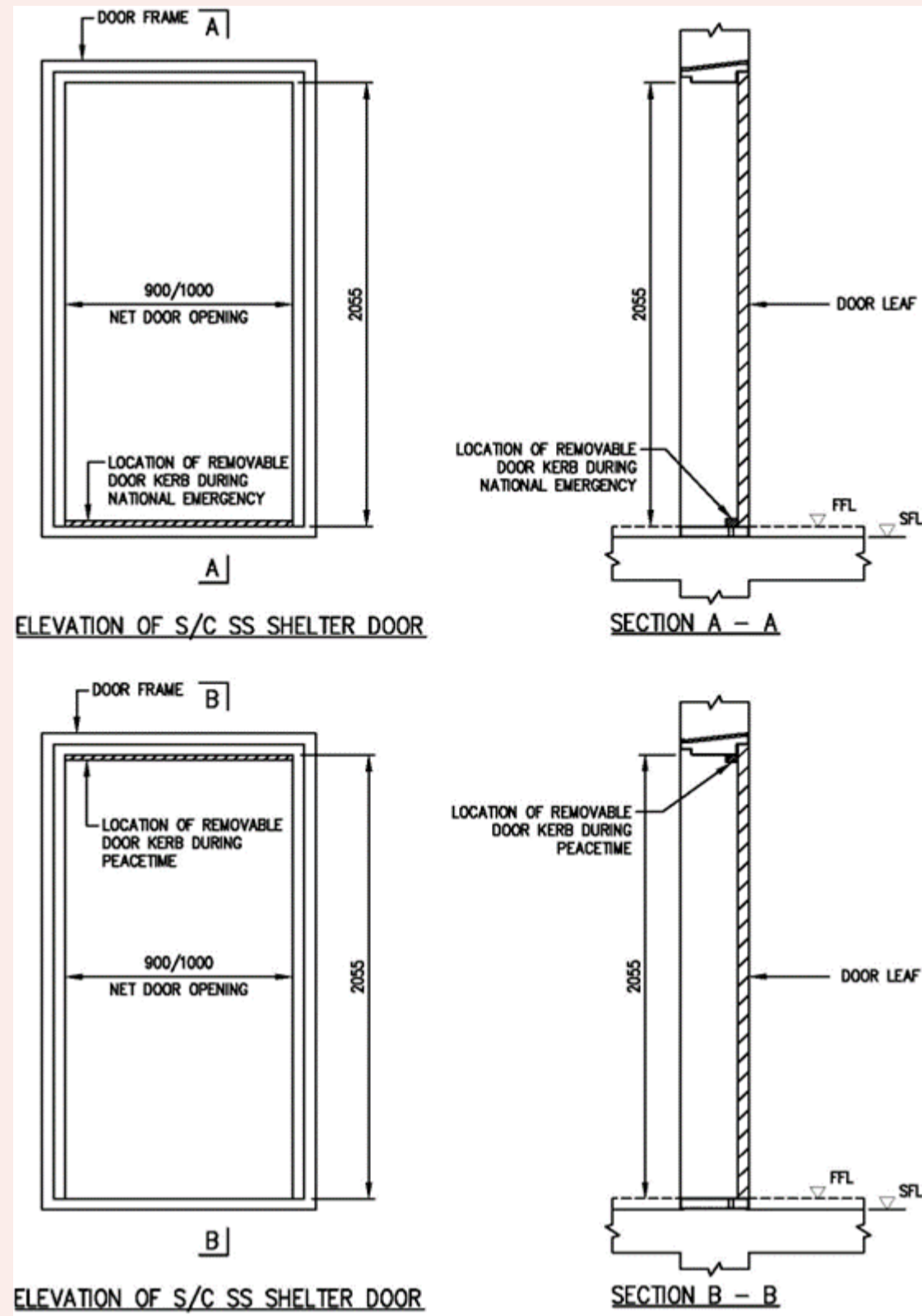

CLAUSE 5.5 SPECIFICATIONS OF SS DOOR NOTICE

a. Manner of Application:

To be affixed on the internal SS door by pressure sensitive and strong adhesive.

b. Special Features:

Non-brittle, rub and mar resistant, storage stability and colour fastness under light

c. Text, Lettering, Layout:

Conform to sample notice

d. Colours:

Background is light yellow, lettering is black, sub- headings, border and triangular logo area are red

Clause No.	Amendment Date	Effective Date	Clause Status	Clause Before Amendment	Circular Date
------------	----------------	----------------	---------------	-------------------------	---------------

CLAUSE 6.1 GENERAL

As the SS is designed to resist weapon effects, good workmanship is essential to achieve the designed protection level.

CLAUSE 6.2 STRUCTURAL WORKS

The following shall be observed:

- a. Only the non-removable type of form-tie (form-tie without through opening) to secure formwork before casting of SS wall is permitted. Upon the removal of every recessible type of plastic cones from the form-tie, the recess shall be sealed with non-shrink grout. The use of reinforcement bar as form-tie is not permitted.
- b. To avoid bending, warping or displacement of HS door frame and honeycombing due to inadequate compaction or leakage of cementitious grout, additional precaution to ensure adequate compaction shall be taken while casting the concrete near the SS door frame.
- c. All embedded items shall be placed and tightly secured in their intended location to ensure their stability during casting. All hacking and drilling of SS tower walls, ceiling slabs or floor slabs are not permitted without prior approval from the Commissioner of Building Control.
- d. The exposed surfaces of SS walls and soffit of SS ceiling slabs shall be cast with smooth concrete finish. A maximum of 2mm thick skim coat on the internal face of the SS walls and ceiling slabs of SS is allowed.
- e. The concrete structural elements shall be adequately compacted to ensure air- tightness. Concrete areas with segregation or honeycombing shall not be hacked and plastered back without prior approval from the Commissioner of Building Control.
- f. Irregularities of exposed surfaces shall not be hacked and plastered back without prior approval from the Commissioner of Building Control.
- g. Method statement of the remedial work on structural elements, including SS door frame, shall be approved by the Commissioner of Building Control.

CLAUSE 6.3 SS DOOR

The following shall be observed:

- a. Allowing an opening in the SS wall and later erecting the SS door frame and door leaf in this opening, followed by casting concrete around it, is not permitted.
- b. When casting the SS wall with SS door frame, a dummy door leaf of adequate design shall be placed to ensure the stability and prevent the bending, warping or displacement of the SS door frame during concreting.
- c. The FFL of the floor slab outside the SS shall be done such that the SS door can be opened adequately for the peacetime use of the SS.

CLAUSE 6.4 PEACETIME REQUIREMENT OF VENTILATION SLEEVES

For ventilation purposes during peacetime, at least 25% of total area of the two ventilation sleeve openings in the SS walls shall be kept uncovered.

In the case of S/C SS and scissor S/C SS, all ventilation sleeve openings shall be fully closed.

CLAUSE 6.5 COMMISSIONING REQUIREMENTS

All electrical and communication fixtures such as switch and lighting point, electrical socket outlets, communication line for telephony outlet, including SS door notice, rescue hatch and cat-ladder (both applicable to SS), blast hatch (applicable to S/C SS or scissor S/C SS) shall be provided inside the completed SS. The service conduits with electrical cables serving the SS shall be provided prior to commissioning.

A SS is considered commissioned only if the SS passes all the following tests in one inspection:

- a. Light penetration test of SS door - an acceptable test method to check on light penetration into the SS is to use torchlight from the exterior of SS door. The test is considered to have passed if no light could be seen from the inside of SS.
- b. Chalk mark test on the SS door - an acceptable test method is to apply chalk to the part of the door frame where the door seal will come into contact with when the door is closed. The test is considered to have passed if there is an unbroken and uniform transfer of the chalk markings onto the door seal when the door is closed and re-opened.
- c. Air-tightness test of the SS - an acceptable test method is to pressurise the SS and measure the rate of pressure drop or the pressure difference between the interior and exterior of the SS. The *pressure gauge can be used for the test. The SS is pressurised by pumping air into the SS such that there is a pressure difference of 250 Pa* between inside and outside of SS. The SS is considered to have passed the test if the pressure gauge shows more than or equal to 50 Pa after 45 seconds.

Except in the case of S/C SS or scissor S/C SS, the ventilation sleeves of the SS, which have been closed for the commissioning tests, shall be opened after the tests to comply with [Clause 6.4](#) for ventilation during peacetime.

* The pressure gauge used should have a dial size with a scale of 0 to 50mm or 0 to 500 Pa. (Note: 1 mm = 10 Pa).

Clause No.	Amendment Date	Effective Date	Clause Status	Clause Before Amendment	Circular Date
------------	----------------	----------------	---------------	-------------------------	---------------

CLAUSE 7.1 GENERAL

Any repair or alteration or renovation works, which are likely to weaken or damage any structural elements of the SS or NS, is not permitted.

CLAUSE 7.2 PERMITTED AND NOT PERMITTED WORKS

7.2.1 Permitted Works in SS

- a. Laying of floor tiles bonded to wet cement mortar. The total thickness of floor finishes and screed is not to exceed 50mm.
- b. Laying of floor skirting tiles (up to a maximum of 100mm high) by bonding them with wet cement mortar to SS walls.
- c. Laying of vinyl or linoleum flooring is permitted in SS but not permitted in S/C SS or scissor S/C SS.
- d. Applying splatter dash or equivalent to the external face of SS walls only to provide rough surface for feature wall panels or wall tiles installation.
- e. Painting of walls, ceiling or door. In the case of SS door, owners shall not cover up or paint over the SS door notice (See [Clause 5.3](#)), locking bolts or door seal. The old paint coat on door and door frame is to be removed prior to repainting to avoid increase in paint thickness resulting in difficulty in closing and opening of the door. The new paint coat must be dried up completely before closing the door as wet or damp paint will cause the door/rubber gasket to stick onto the door frame when opening the closed door.
- f. Painting on only the exterior face of the 10mm fragmentation stainless steel plate of the ventilation sleeves.
- g. Drilling into internal face of SS walls and ceiling slabs to a depth of not more than 50mm to affix inserts and removable screws is permitted in SS but not permitted in S/C SS or scissor S/C SS. Fixtures such as pictures, posters, cabinets or shelves mounted on the internal face of SS walls will have to be removed by the owners within 48 hours upon notification. There is no restriction to the diameter of the non-metallic insert as long as it does not exceed 50mm in length. It is the owner's responsibility to ensure that the strength of the insert is adequately provided for the intended purpose.
- h. Power driven nails are allowed only on external face of the SS walls to facilitate flexibility in mounting of features/fixtures by owners.
- i. Removal of the fragmentation plates (Clause 4.4) covering the ventilation openings is permitted for SS but not permitted in S/C SS or scissor S/C SS. The removal of fragmentation for SS shall comply with the following conditions:
 - i. The plates (after removal) shall be securely mounted with removable screws on non-metallic inserts not exceeding 50mm deep on one of the internal face of SS walls.
 - ii. After the removal of plates, the bolts and nuts shall be installed back to their original positions on the ventilation sleeves.
 - iii. Closing or covering up of ventilation openings by removable aesthetic or architectural finishes is allowed, provided that at least 25% of the total area of the two openings shall be left uncovered for ventilation purposes during peacetime.
- j. The minimum clearance from the fragmentation plate to RC beam or structure or service shall be 50mm. Where RC beam or structure or service is fronting the fragmentation plate of ventilation sleeve, the clear distance between them shall be at least 500mm. Refer to [FIGURE 4.3.1\(a\)](#).

Figures & Tables

FIGURE 4.3.1(a): MINIMUM CLEARANCE FOR FRAGMENTATION PLATE

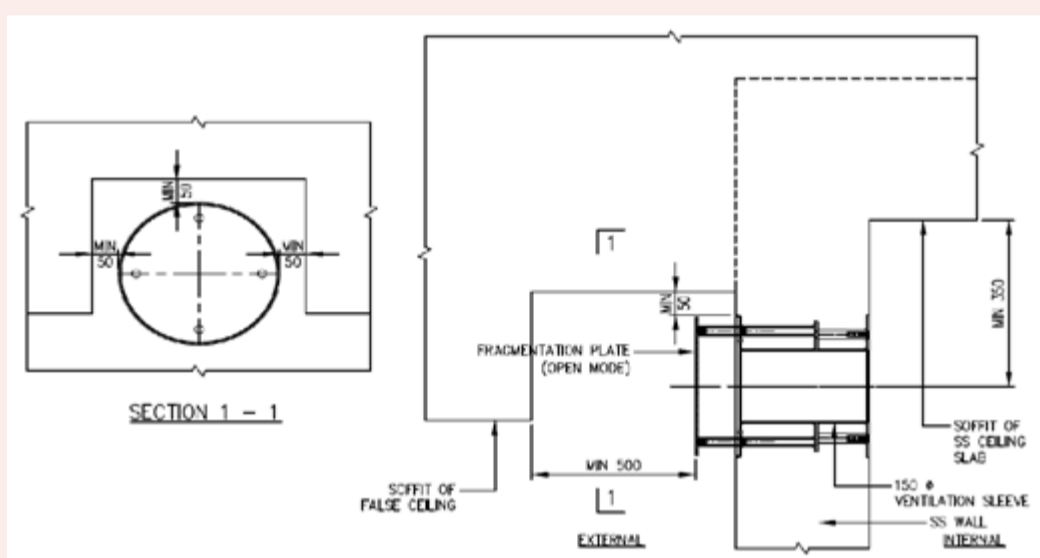

- k. Where false ceilings, which are provided on the exterior of the SS, are to be installed at a level below the ventilation sleeves, there shall be one perforated access panel of a minimum size of 600mm x 600mm to be provided directly below each ventilation sleeve. Refer to [FIGURE 4.3.2](#).

Figures & Tables

FIGURE 4.3.2: PERFORATED ACCESS PANEL BELOW VENTILATION SLEEVE

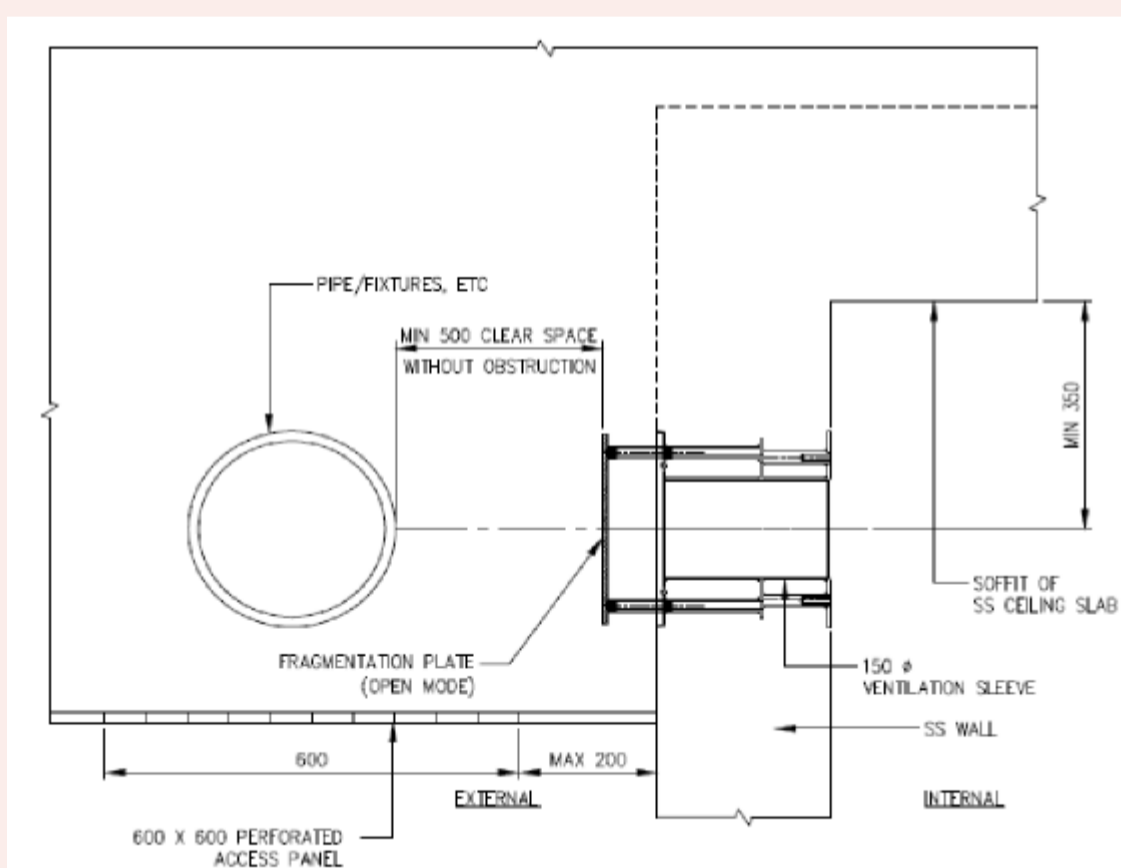

7.2.2 Not Permitted Works in SS

- a. Laying of wall tiles or spray of rock tone finish, cement sand finish and gypsum plastering on the internal faces of SS walls.
- b. Laying of floor tiles using adhesive materials.
- c. Laying of 2nd layer of tiles on floor or skirting tiles.
- d. Installation of cornices within the SS.
- e. Installation works with fixings using power driving nails into the internal SS walls
- f. Tampering with, removing or covering up of the SS door notice. The SS door notice provides important information to the occupants on the use of the SS.
- g. Hacking and drilling of SS walls, floor slabs, and ceiling slabs without prior approval from the Commissioner of Building Control, other than drilling permitted in [Clause 7.2.1\(g\)](#) and [7.2.1\(h\)](#) and shall not exceed 50mm.
- h. Hacking to both internal and external face of the SS walls to form key for tiling.
- i. Hacking on external face of SS wall for mounting of feature wall panels or wall tiles installation.
- j. Modifying, changing, removing or tampering of SS door without prior approval from the Commissioner of Building Control.
- k. Modifying, altering or tampering with any part of the ventilation openings, plates and the mounting devices such as bolts and nuts without prior approval from the Commissioner of Building Control.

1. Painting to the interior face of the 10mm fragmentation stainless steel plate of the ventilation sleeves, the ventilation sleeves, “O” ring rubber gaskets and the four or eight numbers of stainless steel bolts which hold the steel plate to the sleeves.

7.2.3 Not Permitted Works in NS

- a. Hacking and drilling of NS walls, floor slabs, and ceiling slabs without prior approval from the Commissioner of Building Control, other than drilling into NS walls and ceiling slab to affix removable screws on inserts, provided the depth of the insert shall not exceed 50mm.
- b. Modifying, changing, removing or tampering of SS door without prior approval from the Commissioner of Building Control.

Clause No.	Amendment Date	Effective Date	Clause Status	Clause Before Amendment	Circular Date
------------	----------------	----------------	---------------	-------------------------	---------------

CLAUSE 8.1 GENERAL

This Chapter stipulates requirements relating to the certification of shelter products regulated by SCDF under the Product Listing Scheme. These requirements include the acceptable test standards, certification scheme and surveillance regime for the regulated shelter product (refer to Table 8.1).

For the full list of requirements, this Chapter shall be read in conjunction with the Civil Defence Shelter Act (CDSA) and CT 23 of SAC's "Criteria for Product Certification Bodies (Regulated Shelter Products)".

Figures & Tables

TABLE 8.1 : LIST OF REGULATED SHELTER PRODUCT

PRODUCTS	ACCEPTABLE STANDARDS	CERTIFICATION SCHEME	SURVEILLANCE REGIME	
			TESTING	FACTORY AND SITE INSPECTION
Storey Shelter Door	Refer to Table 8.2	Scheme 5 (Label issued)	Once every 3 years for cyclic test. Annually for water tightness test, dimension check, CED coating test & rubber gasket test.	At least once annually or by trigger (every 200 labels).

TABLE 8.2: TEST STANDARDS AND SPECIFICATIONS FOR STOREY SHELTER DOOR

TABLE 8.2: TEST STANDARDS AND SPECIFICATIONS FOR STOREY SHELTER DOOR		
TYPE TESTS – SCHEME TYPE 5		
S/N	TEST	STANDARD/SPECIFICATION
1	Door locking mechanism cyclic test (Once in 3 years)	<p><u>Test Cycles</u></p> <p>The entire test shall consist of 60,000 cycles, which in turn comprise two cyclic types:</p> <ul style="list-style-type: none"> Type A : 10,000 in Civil Defence (CD) mode when the lock bolts are activated. Type B : 50,000 for normal opening and closing of door (based on 900 angle of opening function). <p>(Note: Type A cycles are to be performed interspersed between the Type B cycles in the ratio 1:5, i.e. 1 Type A cycle to be done after every 5 Type B cycles.)</p> <p><u>Test Method and Requirements</u></p> <ul style="list-style-type: none"> The test is conducted using the test rig designed to be able to support the doorset and holding it rigidly in place, preventing any movement that may occur during the tests. 5 Type B cycles to be carried out. Each cycle shall consist of the latch of lockset unlatching (with its level handle completing at 900 angle movement), followed by the door leaf opening to 900 angle and then by the closing of the door leaf and finally latching in place. During each cycle, the lockset shall be able to latch fully. After the 5 Type B cycles, 1 Type A cycle to be performed. The type A cycle is a 900 angle movement of the lever handle of the lockset in locking and unlocking the doorset. During each cycle, the lockset shall fully engage the bolts onto the door frame, with the lever handle completing the full cycle of operation without straining. This pattern of 5 Type B cycles followed by 1 Type A cycle is to be repeated 10,000 times. <p><u>After completion of 60,000 cycles</u></p> <ul style="list-style-type: none"> After the test, the doorset shall be checked manually that it is still able to lock in place without causing any strains and all functions of the lockset shall still operate. Check that there shall be no damages or evidence of undue wear or loosening of any parts of the doorset including the hardware installed or other defects that may impair its reliability of functioning and the test leaf shall remain connected to the frame. Check that the lockset's spring bolt through the striking plate shall continue to function correctly and be able to return to its normally extended position under its own spring pressure and all functions of the lockset shall still operate. Check for visible cracking or breakage of any components on the hinges and check that the doorset is capable of closing properly, maintaining all clearances between leaf to frame and floor as measured before the test.
2	Water-tightness test	Water tightness test shall be carried out on the door leaf and frame assembly in their closed position. The enclosure formed by the door leaf and frame assembly in their closed position shall be filled with water to a uniform depth of 25mm of water for a period of 2 hours. There shall be no seepage of water within this period.
3	CED/Galvanised Coating Test	<p><u>CED</u></p> <ul style="list-style-type: none"> ASTM D3359 - Rating 5B (no removal of coating). SS5 : Part F2 - The coating shall withstand test load of 2000g. ASTM 3363 - 2H shall be the hardest pencil that does not scratch the film. SS5 : Part B1 - Dry film thickness shall be $20 \pm 5\mu\text{m}$ SS5 : Part G1. Test duration = 500 hours - The coating may have any quantity of Size 2 blisters but shall have no more than Density 2 Size 3 blisters as illustrated in ISO 4628-2. - Degree of rusting shall not be more than scale Ri 2 according to ISO 4628-3. SS5 : Part G6. Test duration = 500 hours - The coating shall have no more than Density 2 Size 2 blisters as illustrated in ISO 4628-2. - Degree of rusting shall not be more than scale Ri 1 accordingly to ISO 4628-3. <p><u>Electro-galvanised</u></p> <ul style="list-style-type: none"> ASTM A90 - Coating thickness = 3.5 microns minimum.
4	Rubber gasket test	ASTM D1056 (Grade 2A3, 2A4, 2A5, 2B3, 2B4 or 2B5).
SURVEILLANCE TESTS – SCHEME TYPE 5		
1	Door locking mechanism cyclic test	<u>Test Cycles</u>

		<p>The entire test shall consist of 60,000 cycles, which in turn comprise two cyclic types:</p> <ul style="list-style-type: none"> • Type A : 10,000 in Civil Defence (CD) mode when the lock bolts are activated. • Type B :: 50,000 for normal opening and closing of door (based on 90° angle of opening function). <p>(Note: Type A cycles are to be performed interspersed between the Type B cycles in the ratio 1:5, i.e. 1 Type A cycle to be done after every 5 Type B cycles.)</p> <p><u>Test Method and Requirements</u></p> <ul style="list-style-type: none"> • The test is conducted using the test rig designed to be able to support the doorset and holding it rigidly in place, preventing any movement that may occur during the tests. • 5 Type B cycles to be carried out. Each cycle shall consist of the latch of lockset unlatching (with its level handle completing at 90° angle movement), followed by the door leaf opening to 90° angle and then by the closing of the door leaf and finally latching in place. During each cycle, the lockset shall be able to latch fully. • After the 5 Type B cycles, 1 Type A cycle to be performed. The type A cycle is a 90° angle movement of the lever handle of the lockset in locking and unlocking the doorset. During each cycle, the lockset shall fully engage the bolts onto the door frame, with the lever handle completing the full cycle of operation without straining. • This pattern of 5 Type B cycles followed by 1 Type A cycle is to be repeated 10,000 times. <p><u>After completion of 60,000 cycles</u></p> <ul style="list-style-type: none"> • After the test, the doorset shall be checked manually that it is still able to lock in place without causing any strains and all functions of the lockset shall still operate. • Check that there shall be no damages or evidence of undue wear or loosening of any parts of the doorset including the hardware installed or other defects that may impair its reliability of functioning and the test leaf shall remain connected to the frame. • Check that the lockset's spring bolt through the striking plate shall continue to function correctly and be able to return to its normally extended position under its own spring pressure and all functions of the lockset shall still operate. • Check for visible cracking or breakage of any components on the hinges and check that the doorset is capable of closing properly, maintaining all clearances between leaf to frame and floor as measured before the test.
2	Water-tightness test	Water tightness test shall be carried out on the door leaf and frame assembly in their closed position. The enclosure formed by the door leaf and frame assembly in their closed position shall be filled with water to a uniform depth of 25mm of water for a period of 2 hours. There shall be no seepage of water within this period.
3	Production test	Dimensional checks in accordance to approved drawings. The door frame can be double rebated to facilitate the installation of a fire door.
4	CED/Galvanised Coating Test	<p><u>CED</u></p> <ul style="list-style-type: none"> • ASTM D3359 <ul style="list-style-type: none"> - Rating 5B (no removal of coating). • SS5 : Part F2 <ul style="list-style-type: none"> - The coating shall withstand test load of 2000g. • ASTM 3363 <ul style="list-style-type: none"> - 2H shall be the hardest pencil that does not scratch the film. • SS5 : Part B1 <ul style="list-style-type: none"> - Dry film thickness shall be 20 ± 5µm. • SS5 : Part G1. Test duration = 500 hours <ul style="list-style-type: none"> - The coating may have any quantity of Size 2 blisters but shall have no more than Density 2 Size 3 blisters as illustrated in ISO 4628-2. - Degree of rusting shall not be more than scale Ri 2 according to ISO 4628-3. • SS5 : Part G6. Test duration = 500 hours <ul style="list-style-type: none"> - The coating shall have no more than Density 2 Size 2 blisters as illustrated in ISO 4628-2. - Degree of rusting shall not be more than scale Ri 1 accordingly to ISO 4628-3. <p><u>Electro-galvanised</u></p> <ul style="list-style-type: none"> • ASTM A90 <ul style="list-style-type: none"> - Coating thickness = 3.5 microns minimum.
5	Rubber gasket test	ASTM D1056 (Grade 2A3, 2A4, 2A5, 2B3, 2B4 or 2B5)

CLAUSE 8.2 DEFINITIONS

8.2.1 Accredited Certification Body

“Accredited certification body” (CB) refers to a body corporate or corporation incorporated or constituted under the law of Singapore, accredited under the Singapore Accreditation Council (SAC)’s certification body accreditation scheme administered by the Enterprise Singapore Board.

8.2.2 Accredited Laboratory

“Accredited laboratory” refers to a body corporate or corporation providing laboratory testing services, which is accredited under SAC’s laboratory accreditation scheme administered by the Enterprise Singapore Board, or recognised under the International Laboratory Accreditation Cooperation (ILAC) Mutual Recognition Agreement/Arrangement between Singapore and other countries.

8.2.3 Certificate of Conformity (CoC)

“Certificate of Conformity” refers to a certificate issued by CBs for a regulated shelter product that meets product testing standards and certification requirements. These certified products shall be recorded in a product directory on the CB’s website for reference and verification of the CoCs’ validity.

8.2.4 Local Representative

“Local representative” refers to the Singapore-registered agent/partner appointed by a foreign CoC holder, in order for its certified regulated shelter products to be supplied in Singapore.

8.2.5 Mutual Recognition Arrangement/Agreement (MRA)

“Mutual Recognition Arrangement” or “Mutual Recognition Agreement” refers to the arrangements signed between SAC and other international assessment bodies, which mutually recognise reports and certificates issued by an accredited Conformity Assessment Body (CAB) as equivalent to their own accreditation requirements.

8.2.6 Product Listing Scheme (PLS)

“Product listing scheme” refers to the third-party certification scheme administered by SCDF for regulated shelter products.

8.2.7 Scheme Type 5 (Scheme 5)

“Scheme Type 5” consists of type testing and factory inspection during initial certification, and ongoing assessment of the entire quality management system, including auditing the production process and management system. Surveillance testing of the product is done either from the market or at the point of production, or both, to check that items produced fulfil the specified requirements.

8.2.8 Serial Label

“Serial label” refers to a certification label issued by CBs, with unique serial numbers. These are affixed to certified regulated shelter products, such as SS doors (refer to Table 8.1). Such labels allow tracing of these products to their corresponding CoC and the specific installation location of each product.

Figures & Tables

TABLE 8.1 : LIST OF REGULATED SHELTER PRODUCT

PRODUCTS	ACCEPTABLE STANDARDS	CERTIFICATION SCHEME	SURVEILLANCE REGIME	
			TESTING	FACTORY AND SITE INSPECTION
Storey Shelter Door	Refer to Table 8.2	Scheme 5 (Label issued)	Once every 3 years for cyclic test. Annually for water tightness test, dimension check, CED coating test & rubber gasket test.	At least once annually or by trigger (every 200 labels).

TABLE 8.2: TEST STANDARDS AND SPECIFICATIONS FOR STOREY SHELTER DOOR

TABLE 8.2: TEST STANDARDS AND SPECIFICATIONS FOR STOREY SHELTER DOOR		
TYPE TESTS – SCHEME TYPE 5		
S/N	TEST	STANDARD/SPECIFICATION
1	Door locking mechanism cyclic test (Once in 3 years)	<p><u>Test Cycles</u></p> <p>The entire test shall consist of 60,000 cycles, which in turn comprise two cyclic types:</p> <ul style="list-style-type: none"> Type A : 10,000 in Civil Defence (CD) mode when the lock bolts are activated. Type B : 50,000 for normal opening and closing of door (based on 900 angle of opening function). <p>(Note: Type A cycles are to be performed interspersed between the Type B cycles in the ratio 1:5, i.e. 1 Type A cycle to be done after every 5 Type B cycles.)</p> <p><u>Test Method and Requirements</u></p> <ul style="list-style-type: none"> The test is conducted using the test rig designed to be able to support the doorset and holding it rigidly in place, preventing any movement that may occur during the tests. 5 Type B cycles to be carried out. Each cycle shall consist of the latch of lockset unlatching (with its level handle completing at 900 angle movement), followed by the door leaf opening to 900 angle and then by the closing of the door leaf and finally latching in place. During each cycle, the lockset shall be able to latch fully. After the 5 Type B cycles, 1 Type A cycle to be performed. The type A cycle is a 900 angle movement of the lever handle of the lockset in locking and unlocking the doorset. During each cycle, the lockset shall fully engage the bolts onto the door frame, with the lever handle completing the full cycle of operation without straining. This pattern of 5 Type B cycles followed by 1 Type A cycle is to be repeated 10,000 times. <p><u>After completion of 60,000 cycles</u></p> <ul style="list-style-type: none"> After the test, the doorset shall be checked manually that it is still able to lock in place without causing any strains and all functions of the lockset shall still operate. Check that there shall be no damages or evidence of undue wear or loosening of any parts of the doorset including the hardwares installed or other defects that may impair its reliability of functioning and the test leaf shall remain connected to the frame. Check that the lockset’s spring bolt through the striking plate shall continue to function correctly and be able to return to its normally extended position under its own spring pressure and all functions of the lockset shall still operate. Check for visible cracking or breakage of any components on the hinges and check that the doorset is capable of closing properly, maintaining all clearances between leaf to frame and floor as measured before the test.
2	Water-tightness test	Water tightness test shall be carried out on the door leaf and frame assembly in their closed position. The enclosure formed by the door leaf and frame assembly in their closed position shall be filled with water to a uniform depth of 25mm of water for a period of 2 hours. There shall be no seepage of water within this period.

3	CED/Galvanised Coating Test	<p>CED</p> <ul style="list-style-type: none"> • ASTM D3359 - Rating 5B (no removal of coating). • SS5 : Part F2 - The coating shall withstand test load of 2000g. • ASTM 3363 - 2H shall be the hardest pencil that does not scratch the film. • SS5 : Part B1 - Dry film thickness shall be 20 ± 5µm • SS5 : Part G1. Test duration = 500 hours - The coating may have any quantity of Size 2 blisters but shall have no more than Density 2 Size 3 blisters as illustrated in ISO 4628-2. - Degree of rusting shall not be more than scale Ri 2 according to ISO 4628-3. • SS5 : Part G6. Test duration = 500 hours - The coating shall have no more than Density 2 Size 2 blisters as illustrated in ISO 4628-2. - Degree of rusting shall not be more than scale Ri 1 accordingly to ISO 4628-3. <p>Electro-galvanised</p> <ul style="list-style-type: none"> • ASTM A90 - Coating thickness = 3.5 microns minimum.
4	Rubber gasket test	ASTM D1056 (Grade 2A3, 2A4, 2A5, 2B3, 2B4 or 2B5).
SURVEILLANCE TESTS – SCHEME TYPE 5		
1	Door locking mechanism cyclic test	<p>Test Cycles</p> <p>The entire test shall consist of 60,000 cycles, which in turn comprise two cyclic types:</p> <ul style="list-style-type: none"> • Type A : 10,000 in Civil Defence (CD) mode when the lock bolts are activated. • Type B :: 50,000 for normal opening and closing of door (based on 900 angle of opening function). <p>(Note: Type A cycles are to be performed interspersed between the Type B cycles in the ratio 1:5, i.e. 1 Type A cycle to be done after every 5 Type B cycles.)</p> <p>Test Method and Requirements</p> <ul style="list-style-type: none"> • The test is conducted using the test rig designed to be able to support the doorset and holding it rigidly in place, preventing any movement that may occur during the tests. • 5 Type B cycles to be carried out. Each cycle shall consist of the latch of lockset unlatching (with its level handle completing at 900 angle movement), followed by the door leaf opening to 900 angle and then by the closing of the door leaf and finally latching in place. During each cycle, the lockset shall be able to latch fully. • After the 5 Type B cycles, 1 Type A cycle to be performed. The type A cycle is a 900 angle movement of the lever handle of the lockset in locking and unlocking the doorset. During each cycle, the lockset shall fully engage the bolts onto the door frame, with the lever handle completing the full cycle of operation without straining. • This pattern of 5 Type B cycles followed by 1 Type A cycle is to be repeated 10,000 times. <p>After completion of 60,000 cycles</p> <ul style="list-style-type: none"> • After the test, the doorset shall be checked manually that it is still able to lock in place without causing any strains and all functions of the lockset shall still operate. • Check that there shall be no damages or evidence of undue wear or loosening of any parts of the doorset including the hardware installed or other defects that may impair its reliability of functioning and the test leaf shall remain connected to the frame. • Check that the lockset's spring bolt through the striking plate shall continue to function correctly and be able to return to its normally extended position under its own spring pressure and all functions of the lockset shall still operate. • Check for visible cracking or breakage of any components on the hinges and check that the doorset is capable of closing properly, maintaining all clearances between leaf to frame and floor as measured before the test.
2	Water-tightness test	Water tightness test shall be carried out on the door leaf and frame assembly in their closed position. The enclosure formed by the door leaf and frame assembly in their closed position shall be filled with water to a uniform depth of 25mm of water for a period of 2 hours. There shall be no seepage of water within this period.
3	Production test	Dimensional checks in accordance to approved drawings. The door frame can be double rebated to facilitate the installation of a fire door.
4	CED/Galvanised Coating Test	<p>CED</p> <ul style="list-style-type: none"> • ASTM D3359 - Rating 5B (no removal of coating). • SS5 : Part F2 - The coating shall withstand test load of 2000g. • ASTM 3363 - 2H shall be the hardest pencil that does not scratch the film. • SS5 : Part B1 - Dry film thickness shall be 20 ± 5µm. • SS5 : Part G1. Test duration = 500 hours - The coating may have any quantity of Size 2 blisters but shall have no more than Density 2 Size 3 blisters as illustrated in ISO 4628-2. - Degree of rusting shall not be more than scale Ri 2 according to ISO 4628-3. • SS5 : Part G6. Test duration = 500 hours - The coating shall have no more than Density 2 Size 2 blisters as illustrated in ISO 4628-2. - Degree of rusting shall not be more than scale Ri 1 accordingly to ISO 4628-3. <p>Electro-galvanised</p> <ul style="list-style-type: none"> • ASTM A90 - Coating thickness = 3.5 microns minimum.
5	Rubber gasket test	ASTM D1056 (Grade 2A3, 2A4, 2A5, 2B3, 2B4 or 2B5)

8.2.9 Surveillance Window

'Surveillance window', also known as "surveillance cycle", refers to the period of 12 or 36 months (as stipulated in Table 8.1), starting from the date that a CoC is issued in relation to a regulated shelter product, and every subsequent period of 12 or 36 months or shorter, if the CoC expires, or is terminated or withdrawn. Products may be subjected to post -certification testing and/or inspection, based on the surveillance window.

Figures & Tables

TABLE 8.1 : LIST OF REGULATED SHELTER PRODUCT

PRODUCTS	ACCEPTABLE STANDARDS	CERTIFICATION SCHEME	SURVEILLANCE REGIME	
			TESTING	FACTORY AND SITE INSPECTION
Storey Shelter Door	Refer to Table 8.2	Scheme 5 (Label issued)	Once every 3 years for cyclic test. Annually for water tightness test, dimension check, CED coating test & rubber gasket test.	At least once annually or by trigger (every 200 labels).

TABLE 8.2: TEST STANDARDS AND SPECIFICATIONS FOR STOREY SHELTER DOOR

TABLE 8.2: TEST STANDARDS AND SPECIFICATIONS FOR STOREY SHELTER DOOR		
TYPE TESTS – SCHEME TYPE 5		
S/N	TEST	STANDARD/SPECIFICATION
1	Door locking mechanism cyclic test (Once in 3 years)	<p><u>Test Cycles</u></p> <p>The entire test shall consist of 60,000 cycles, which in turn comprise two cyclic types:</p> <ul style="list-style-type: none"> Type A : 10,000 in Civil Defence (CD) mode when the lock bolts are activated. Type B : 50,000 for normal opening and closing of door (based on 900 angle of opening function). <p>(Note: Type A cycles are to be performed interspersed between the Type B cycles in the ratio 1:5, i.e. 1 Type A cycle to be done after every 5 Type B cycles.)</p> <p><u>Test Method and Requirements</u></p> <ul style="list-style-type: none"> The test is conducted using the test rig designed to be able to support the doorset and holding it rigidly in place, preventing any movement that may occur during the tests. 5 Type B cycles to be carried out. Each cycle shall consist of the latch of lockset unlatching (with its level handle completing at 900 angle movement), followed by the door leaf opening to 900 angle and then by the closing of the door leaf and finally latching in place. During each cycle, the lockset shall be able to latch fully. After the 5 Type B cycles, 1 Type A cycle to be performed. The type A cycle is a 900 angle movement of the lever handle of the lockset in locking and unlocking the doorset. During each cycle, the lockset shall fully engage the bolts onto the door frame, with the lever handle completing the full cycle of operation without straining. This pattern of 5 Type B cycles followed by 1 Type A cycle is to be repeated 10,000 times. <p><u>After completion of 60,000 cycles</u></p> <ul style="list-style-type: none"> After the test, the doorset shall be checked manually that it is still able to lock in place without causing any strains and all functions of the lockset shall still operate. Check that there shall be no damages or evidence of undue wear or loosening of any parts of the doorset including the hardware installed or other defects that may impair its reliability of functioning and the test leaf shall remain connected to the frame. Check that the lockset's spring bolt through the striking plate shall continue to function correctly and be able to return to its normally extended position under its own spring pressure and all functions of the lockset shall still operate. Check for visible cracking or breakage of any components on the hinges and check that the doorset is capable of closing properly, maintaining all clearances between leaf to frame and floor as measured before the test.
2	Water-tightness test	Water tightness test shall be carried out on the door leaf and frame assembly in their closed position. The enclosure formed by the door leaf and frame assembly in their closed position shall be filled with water to a uniform depth of 25mm of water for a period of 2 hours. There shall be no seepage of water within this period.
3	CED/Galvanised Coating Test	<p><u>CED</u></p> <ul style="list-style-type: none"> ASTM D3359 - Rating 5B (no removal of coating). SS5 : Part F2 - The coating shall withstand test load of 2000g. ASTM 3363 - 2H shall be the hardest pencil that does not scratch the film. SS5 : Part B1 - Dry film thickness shall be 20 ± 5µm SS5 : Part G1. Test duration = 500 hours - The coating may have any quantity of Size 2 blisters but shall have no more than Density 2 Size 3 blisters as illustrated in ISO 4628-2. - Degree of rusting shall not be more than scale Ri 2 according to ISO 4628-3. SS5 : Part G6. Test duration = 500 hours - The coating shall have no more than Density 2 Size 2 blisters as illustrated in ISO 4628-2. - Degree of rusting shall not be more than scale Ri 1 accordingly to ISO 4628-3. <p><u>Electro-galvanised</u></p> <ul style="list-style-type: none"> ASTM A90 - Coating thickness = 3.5 microns minimum.
4	Rubber gasket test	ASTM D1056 (Grade 2A3, 2A4, 2A5, 2B3, 2B4 or 2B5).
SURVEILLANCE TESTS – SCHEME TYPE 5		
1	Door locking mechanism cyclic test	<p><u>Test Cycles</u></p> <p>The entire test shall consist of 60,000 cycles, which in turn comprise two cyclic types:</p> <ul style="list-style-type: none"> Type A : 10,000 in Civil Defence (CD) mode when the lock bolts are activated. Type B :: 50,000 for normal opening and closing of door (based on 900 angle of opening function). <p>(Note: Type A cycles are to be performed interspersed between the Type B cycles in the ratio 1:5, i.e. 1 Type A cycle to be done after every 5 Type B cycles.)</p> <p><u>Test Method and Requirements</u></p> <ul style="list-style-type: none"> The test is conducted using the test rig designed to be able to support the doorset and holding it rigidly in place, preventing any movement that may occur during the tests. 5 Type B cycles to be carried out. Each cycle shall consist of the latch of lockset unlatching (with its level handle completing at 900

		<p>angle movement), followed by the door leaf opening to 900 angle and then by the closing of the door leaf and finally latching in place. During each cycle, the lockset shall be able to latch fully.</p> <ul style="list-style-type: none"> • After the 5 Type B cycles, 1 Type A cycle to be performed. The type A cycle is a 900 angle movement of the lever handle of the lockset in locking and unlocking the doorset. During each cycle, the lockset shall fully engage the bolts onto the door frame, with the lever handle completing the full cycle of operation without straining. • This pattern of 5 Type B cycles followed by 1 Type A cycle is to be repeated 10,000 times. <p><u>After completion of 60,000 cycles</u></p> <ul style="list-style-type: none"> • After the test, the doorset shall be checked manually that it is still able to lock in place without causing any strains and all functions of the lockset shall still operate. • Check that there shall be no damages or evidence of undue wear or loosening of any parts of the doorset including the hardware installed or other defects that may impair its reliability of functioning and the test leaf shall remain connected to the frame. • Check that the lockset's spring bolt through the striking plate shall continue to function correctly and be able to return to its normally extended position under its own spring pressure and all functions of the lockset shall still operate. • Check for visible cracking or breakage of any components on the hinges and check that the doorset is capable of closing properly, maintaining all clearances between leaf to frame and floor as measured before the test.
2	Water-tightness test	Water tightness test shall be carried out on the door leaf and frame assembly in their closed position. The enclosure formed by the door leaf and frame assembly in their closed position shall be filled with water to a uniform depth of 25mm of water for a period of 2 hours. There shall be no seepage of water within this period.
3	Production test	Dimensional checks in accordance to approved drawings. The door frame can be double rebated to facilitate the installation of a fire door.
4	CED/Galvanised Coating Test	<p><u>CED</u></p> <ul style="list-style-type: none"> • ASTM D3359 - Rating 5B (no removal of coating). • SS5 : Part F2 - The coating shall withstand test load of 2000g. • ASTM 3363 - 2H shall be the hardest pencil that does not scratch the film. • SS5 : Part B1 - Dry film thickness shall be 20 ± 5µm. • SS5 : Part G1. Test duration = 500 hours - The coating may have any quantity of Size 2 blisters but shall have no more than Density 2 Size 3 blisters as illustrated in ISO 4628-2. - Degree of rusting shall not be more than scale Ri 2 according to ISO 4628-3. • SS5 : Part G6. Test duration = 500 hours - The coating shall have no more than Density 2 Size 2 blisters as illustrated in ISO 4628-2. - Degree of rusting shall not be more than scale Ri 1 accordingly to ISO 4628-3. <p><u>Electro-galvanised</u></p> <ul style="list-style-type: none"> • ASTM A90 - Coating thickness = 3.5 microns minimum.
5	Rubber gasket test	ASTM D1056 (Grade 2A3, 2A4, 2A5, 2B3, 2B4 or 2B5)

8.2.10 Suspension of CoC

“Suspension of CoC” refers to the temporary invalidation of a CoC by a CB under circumstances not limited to the following:

- Non-compliance to any component of the surveillance regime.
- Products are suspected to not meet shelter requirements but are still in the process of being tested/investigated.
- CoC holder breaching the CB's terms and conditions (including non - payment of fees).

8.2.11 Termination of CoC

“Termination of CoC” refers to the cancellation of a CoC, either on the request of the CoC holder before its expiry, or due to reasons not related to shelter requirements. Examples of such circumstances include:

- CoC holder ceases to supply the product due to business considerations (e.g. shutting down of business, liquidation).
- CoC holder fails to take adequate rectification measures within the given timeframe, despite being suspended for a breach in the CB's terms and conditions (including non-payment of fees).

8.2.12 Type Testing

“Type testing”, also known as prototype testing, refers to testing of a product according to the test standard(s) and specification(s) for that product for the application of CoC, as specified in Table 8.2.

Figures & Tables

TABLE 8.2: TEST STANDARDS AND SPECIFICATIONS FOR STOREY SHELTER DOOR

TYPE TESTS – SCHEME TYPE 5		
S/N	TEST	STANDARD/SPECIFICATION
1	Door locking mechanism cyclic test (Once in 3 years)	<p><u>Test Cycles</u></p> <p>The entire test shall consist of 60,000 cycles, which in turn comprise two cyclic types:</p> <ul style="list-style-type: none"> • Type A : 10,000 in Civil Defence (CD) mode when the lock bolts are activated. • Type B : 50,000 for normal opening and closing of door (based on 900 angle of opening function). <p>(Note: Type A cycles are to be performed interspersed between the Type B cycles in the ratio 1:5, i.e. 1 Type A cycle to be done after every 5 Type B cycles.)</p> <p><u>Test Method and Requirements</u></p> <ul style="list-style-type: none"> • The test is conducted using the test rig designed to be able to support the doorset and holding it rigidly in place, preventing any movement that may occur during the tests. • 5 Type B cycles to be carried out. Each cycle shall consist of the latch of lockset unlatching (with its level handle completing at 900 angle movement), followed by the door leaf opening to 900 angle and then by the closing of the door leaf and finally latching in place. During each cycle, the lockset shall be able to latch fully. • After the 5 Type B cycles, 1 Type A cycle to be performed. The type A cycle is a 900 angle movement of the lever handle of the lockset in locking and unlocking the doorset. During each cycle, the lockset shall fully engage the bolts onto the door frame, with the lever handle completing the full cycle of operation without straining.

		<ul style="list-style-type: none"> This pattern of 5 Type B cycles followed by 1 Type A cycle is to be repeated 10,000 times. <p><u>After completion of 60,000 cycles</u></p> <ul style="list-style-type: none"> After the test, the doorset shall be checked manually that it is still able to lock in place without causing any strains and all functions of the lockset shall still operate. Check that there shall be no damages or evidence of undue wear or loosening of any parts of the doorset including the hardware installed or other defects that may impair its reliability of functioning and the test leaf shall remain connected to the frame. Check that the lockset's spring bolt through the striking plate shall continue to function correctly and be able to return to its normally extended position under its own spring pressure and all functions of the lockset shall still operate. Check for visible cracking or breakage of any components on the hinges and check that the doorset is capable of closing properly, maintaining all clearances between leaf to frame and floor as measured before the test.
2	Water-tightness test	Water tightness test shall be carried out on the door leaf and frame assembly in their closed position. The enclosure formed by the door leaf and frame assembly in their closed position shall be filled with water to a uniform depth of 25mm of water for a period of 2 hours. There shall be no seepage of water within this period.
3	CED/Galvanised Coating Test	<p><u>CED</u></p> <ul style="list-style-type: none"> ASTM D3359 <ul style="list-style-type: none"> - Rating 5B (no removal of coating). SS5 : Part F2 <ul style="list-style-type: none"> - The coating shall withstand test load of 2000g. ASTM 3363 <ul style="list-style-type: none"> - 2H shall be the hardest pencil that does not scratch the film. SS5 : Part B1 <ul style="list-style-type: none"> - Dry film thickness shall be 20 ± 5µm SS5 : Part G1. Test duration = 500 hours <ul style="list-style-type: none"> - The coating may have any quantity of Size 2 blisters but shall have no more than Density 2 Size 3 blisters as illustrated in ISO 4628-2. - Degree of rusting shall not be more than scale Ri 2 according to ISO 4628-3. SS5 : Part G6. Test duration = 500 hours <ul style="list-style-type: none"> - The coating shall have no more than Density 2 Size 2 blisters as illustrated in ISO 4628-2. - Degree of rusting shall not be more than scale Ri 1 accordingly to ISO 4628-3. <p><u>Electro-galvanised</u></p> <ul style="list-style-type: none"> ASTM A90 <ul style="list-style-type: none"> - Coating thickness = 3.5 microns minimum.
4	Rubber gasket test	ASTM D1056 (Grade 2A3, 2A4, 2A5, 2B3, 2B4 or 2B5).
SURVEILLANCE TESTS – SCHEME TYPE 5		
1	Door locking mechanism cyclic test	<p><u>Test Cycles</u></p> <p>The entire test shall consist of 60,000 cycles, which in turn comprise two cyclic types:</p> <ul style="list-style-type: none"> Type A : 10,000 in Civil Defence (CD) mode when the lock bolts are activated. Type B :: 50,000 for normal opening and closing of door (based on 90° angle of opening function). <p>(Note: Type A cycles are to be performed interspersed between the Type B cycles in the ratio 1:5, i.e. 1 Type A cycle to be done after every 5 Type B cycles.)</p> <p><u>Test Method and Requirements</u></p> <ul style="list-style-type: none"> The test is conducted using the test rig designed to be able to support the doorset and holding it rigidly in place, preventing any movement that may occur during the tests. 5 Type B cycles to be carried out. Each cycle shall consist of the latch of lockset unlatching (with its level handle completing at 90° angle movement), followed by the door leaf opening to 90° angle and then by the closing of the door leaf and finally latching in place. During each cycle, the lockset shall be able to latch fully. After the 5 Type B cycles, 1 Type A cycle to be performed. The type A cycle is a 90° angle movement of the lever handle of the lockset in locking and unlocking the doorset. During each cycle, the lockset shall fully engage the bolts onto the door frame, with the lever handle completing the full cycle of operation without straining. This pattern of 5 Type B cycles followed by 1 Type A cycle is to be repeated 10,000 times. <p><u>After completion of 60,000 cycles</u></p> <ul style="list-style-type: none"> After the test, the doorset shall be checked manually that it is still able to lock in place without causing any strains and all functions of the lockset shall still operate. Check that there shall be no damages or evidence of undue wear or loosening of any parts of the doorset including the hardware installed or other defects that may impair its reliability of functioning and the test leaf shall remain connected to the frame. Check that the lockset's spring bolt through the striking plate shall continue to function correctly and be able to return to its normally extended position under its own spring pressure and all functions of the lockset shall still operate. Check for visible cracking or breakage of any components on the hinges and check that the doorset is capable of closing properly, maintaining all clearances between leaf to frame and floor as measured before the test.
2	Water-tightness test	Water tightness test shall be carried out on the door leaf and frame assembly in their closed position. The enclosure formed by the door leaf and frame assembly in their closed position shall be filled with water to a uniform depth of 25mm of water for a period of 2 hours. There shall be no seepage of water within this period.
3	Production test	Dimensional checks in accordance to approved drawings. The door frame can be double rebated to facilitate the installation of a fire door.
4	CED/Galvanised Coating Test	<p><u>CED</u></p> <ul style="list-style-type: none"> ASTM D3359 <ul style="list-style-type: none"> - Rating 5B (no removal of coating). SS5 : Part F2 <ul style="list-style-type: none"> - The coating shall withstand test load of 2000g. ASTM 3363 <ul style="list-style-type: none"> - 2H shall be the hardest pencil that does not scratch the film. SS5 : Part B1 <ul style="list-style-type: none"> - Dry film thickness shall be 20 ± 5µm. SS5 : Part G1. Test duration = 500 hours <ul style="list-style-type: none"> - The coating may have any quantity of Size 2 blisters but shall have no more than Density 2 Size 3 blisters as illustrated in ISO 4628-2. - Degree of rusting shall not be more than scale Ri 2 according to ISO 4628-3. SS5 : Part G6. Test duration = 500 hours <ul style="list-style-type: none"> - The coating shall have no more than Density 2 Size 2 blisters as illustrated in ISO 4628-2. - Degree of rusting shall not be more than scale Ri 1 accordingly to ISO 4628-3. <p><u>Electro-galvanised</u></p>

		<ul style="list-style-type: none"> • ASTM A90 - Coating thickness = 3.5 microns minimum.
5	Rubber gasket test	ASTM D1056 (Grade 2A3, 2A4, 2A5, 2B3, 2B4 or 2B5)

8.2.13 Withdrawal of CoC

“Withdrawal of CoC” refers to the cancellation of a CoC by the CB under circumstances not limited to the following:

- a. Non-compliance with the requirements of the Product Listing Scheme, including:
 - i. Regulated shelter product that is supplied to the industry differs from the prototype described in the CoC and laboratory test report.
 - ii. Misuse of certification mark, logo and certificates.
 - iii. Supply of products from a factory which differs from the factory declared during the CoC application.
- b. Failure to take adequate rectification measures within the given timeframe, despite being suspended for a shelter-related non-compliance.
- c. Non-compliance that failure production process to consistently produce products of acceptable quality, including:
 - i. Failure or refusal of test/analysis of the product.
 - ii. The surveillance regime is not completed within the surveillance window.
- d. Other reasons related to shelter requirements.

CLAUSE 8.3 ACCREDITATION AND CERTIFICATION

8.3.1 General

All regulated shelter products shall be certified and have valid CoCs before they can be used on/in buildings as part of shelter works in Singapore (henceforth, for the purpose of this Chapter, “use in Singapore” shall be taken to mean “on/in buildings as part of shelter works in Singapore”).

8.3.2 Age of Test Reports for Regulated Shelter Products

Certification of regulated shelter products under the Product Listing Scheme shall be based on test report(s) that were issued within the specified timeframes, as listed below.

Certification Scheme (with reference to Table 8.1)	Age of Test Reports that can be Considered for Issuance of CoC
Scheme 5	Less than 5 years

8.3.3 Validity of CoC for Regulated Shelter Products

- a. A CoC for regulated shelter products is valid for 5 years from the date of issuance.
- b. A CoC which is terminated, expired or withdrawn shall be considered permanently invalid, whereas a CoC which is suspended shall be considered temporarily invalid until the suspension is lifted.
- c. The status of the CoC will determine whether the regulated shelter products are permitted to be supplied and used in Singapore. Information relating to the CoCs, including the status, can be verified against CBs’ online directories.
 - i. For products with valid CoCs at the date of delivery to the project site, i.e. not suspended, terminated, expired or withdrawn, these are permitted to be used in Singapore.
 - ii. For products with CoCs that are not valid on the date of delivery to the project site, i.e. suspended, terminated, expired or withdrawn, usage of these products in Singapore is prohibited.
 - iii. Notwithstanding (1), for products with CoCs that were valid on the date of delivery, but are subsequently withdrawn, usage of the affected batches of such products in Singapore is subject to further assessment and investigation by SCDF and/or the CBs.
 - iv. Notwithstanding (1), for products with CoCs that were valid on the date of delivery, but are subsequently suspended for shelter - related reasons, e.g. pending investigation, it is not recommended that such products be used, as the investigation may show that the products are non-compliant and cannot be used (e.g. products that have been installed will need to be replaced/removed).
 - v. CBs shall not allow the termination of a CoC which is suspended for shelter-related reasons, or which is under investigation by SCDF.

8.3.4 Accreditation Requirements

- a. Regulated shelter products used in shelter works shall be certified by a local certification body accredited by SAC.
- b. Regulated shelter products shall be accompanied by test reports from testing laboratories accredited by SAC or recognised by SAC via the International Laboratory Accreditation Cooperation (ILAC) MRA.
- c. Any new CB participating in the PLS shall notify SCDF, in writing, of its accreditation by SAC, and submit its Certificate of Accreditation and Schedule issued by SAC for SCDF’s record. SCDF may request for additional information from the CB.

8.3.5 Certification Requirements

a. General Requirements

CoCs issued for products intended for use in Singapore shall bear SAC’s accreditation mark.

b. Information Submitted for New CoC Applications

The following information, at minimum, shall be submitted to a CB for application of a CoC. Where the information/documents are not provided in English, an official English translation, endorsed by a Notary Public, shall also be provided:

- i. CoC applicant details, including:
 - a. Unique Entity Number (UEN) issued by the Accounting and Corporate Regulatory Authority (ACRA), or foreign equivalent, where applicable.
 - b. Full names of the company directors, or equivalent .
 - c. Name, address, contact number and email address of the company.
 - d. Where the applicant is a foreign company, the details of the appointed local representative, for parts (1)(a) through (1)(c) shall also be included./p>
 - e. Proof of partnership between the local representative and foreign CoC holder.
- ii. Manufacturer’s details, for all the manufacturing plants of components of the regulated shelter product affecting shelter - related requirements, including:
 - a. Country, name, address, contact number and email address of the manufacturer.
- iii. Certification scheme details, including:
 - a. Product category as classified under Table 8.1.
 - b. Certification scheme, according to [Clause 8.2.7](#).
- iv. Product details, including:
 - a. Brand and model, as determined by the manufacturer.
 - b. Density and weight, where applicable, measured in kg/m³ and kg, respectively.
 - c. Dimensions, where applicable, measured in mm.
 - d. Latest product catalogue stipulating the specifications and user instructions.
- v. Details of type tests, including:
 - a. The reference number of the test report.
 - b. Test standards (including version of the test standard, i.e. year) which the product is tested to.

Figures & Tables

TABLE 8.1 : LIST OF REGULATED SHELTER PRODUCT

PRODUCTS	ACCEPTABLE STANDARDS	CERTIFICATION SCHEME	SURVEILLANCE REGIME	
			TESTING	FACTORY AND SITE INSPECTION
Storey Shelter Door	Refer to Table 8.2	Scheme 5 (Label issued)	Once every 3 years for cyclic test. Annually for water tightness test, dimension check, CED coating test & rubber gasket test.	At least once annually or by trigger (every 200 labels).

TABLE 8.2: TEST STANDARDS AND SPECIFICATIONS FOR STOREY SHELTER DOOR

TYPE TESTS – SCHEME TYPE 5		
S/N	TEST	STANDARD/SPECIFICATION
1	Door locking mechanism cyclic test (Once in 3 years)	<p><u>Test Cycles</u></p> <p>The entire test shall consist of 60,000 cycles, which in turn comprise two cyclic types:</p> <ul style="list-style-type: none"> • Type A : 10,000 in Civil Defence (CD) mode when the lock bolts are activated. • Type B : 50,000 for normal opening and closing of door (based on 900 angle of opening function). <p>(Note: Type A cycles are to be performed interspersed between the Type B cycles in the ratio 1:5, i.e. 1 Type A cycle to be done after every 5 Type B cycles.)</p> <p><u>Test Method and Requirements</u></p> <ul style="list-style-type: none"> • The test is conducted using the test rig designed to be able to support the doorset and holding it rigidly in place, preventing any movement that may occur during the tests. • 5 Type B cycles to be carried out. Each cycle shall consist of the latch of lockset unlatching (with its level handle completing at 900 angle movement), followed by the door leaf opening to 900 angle and then by the closing of the door leaf and finally latching in place. During each cycle, the lockset shall be able to latch fully. • After the 5 Type B cycles, 1 Type A cycle to be performed. The type A cycle is a 900 angle movement of the lever handle of the lockset in locking and unlocking the doorset. During each cycle, the lockset shall fully engage the bolts onto the door frame, with the lever handle completing the full cycle of operation without straining. • This pattern of 5 Type B cycles followed by 1 Type A cycle is to be repeated 10,000 times. <p><u>After completion of 60,000 cycles</u></p> <ul style="list-style-type: none"> • After the test, the doorset shall be checked manually that it is still able to lock in place without causing any strains and all functions of the lockset shall still operate. • Check that there shall be no damages or evidence of undue wear or loosening of any parts of the doorset including the hardwares installed or other defects that may impair its reliability of functioning and the test leaf shall remain connected to the frame. • Check that the lockset's spring bolt through the striking plate shall continue to function correctly and be able to return to its normally extended position under its own spring pressure and all functions of the lockset shall still operate. • Check for visible cracking or breakage of any components on the hinges and check that the doorset is capable of closing properly, maintaining all clearances between leaf to frame and floor as measured before the test.
2	Water-tightness test	Water tightness test shall be carried out on the door leaf and frame assembly in their closed position. The enclosure formed by the door leaf and frame assembly in their closed position shall be filled with water to a uniform depth of 25mm of water for a period of 2 hours. There shall be no seepage of water within this period.
3	CED/Galvanised Coating Test	<p><u>CED</u></p> <ul style="list-style-type: none"> • ASTM D3359 - Rating 5B (no removal of coating). • SS5 : Part F2 - The coating shall withstand test load of 2000g. • ASTM 3363 - 2H shall be the hardest pencil that does not scratch the film. • SS5 : Part B1 - Dry film thickness shall be 20 ± 5µm • SS5 : Part G1. Test duration = 500 hours - The coating may have any quantity of Size 2 blisters but shall have no more than Density 2 Size 3 blisters as illustrated in ISO 4628-2. - Degree of rusting shall not be more than scale Ri 2 according to ISO 4628-3. • SS5 : Part G6. Test duration = 500 hours - The coating shall have no more than Density 2 Size 2 blisters as illustrated in ISO 4628-2. - Degree of rusting shall not be more than scale Ri 1 accordingly to ISO 4628-3. <p><u>Electro-galvanised</u></p> <ul style="list-style-type: none"> • ASTM A90 - Coating thickness = 3.5 microns minimum.
4	Rubber gasket test	ASTM D1056 (Grade 2A3, 2A4, 2A5, 2B3, 2B4 or 2B5).
SURVEILLANCE TESTS – SCHEME TYPE 5		
1	Door locking mechanism cyclic test	<p><u>Test Cycles</u></p> <p>The entire test shall consist of 60,000 cycles, which in turn comprise two cyclic types:</p> <ul style="list-style-type: none"> • Type A : 10,000 in Civil Defence (CD) mode when the lock bolts are activated. • Type B :: 50,000 for normal opening and closing of door (based on 900 angle of opening function). <p>(Note: Type A cycles are to be performed interspersed between the Type B cycles in the ratio 1:5, i.e. 1 Type A cycle to be done after every 5 Type B cycles.)</p> <p><u>Test Method and Requirements</u></p> <ul style="list-style-type: none"> • The test is conducted using the test rig designed to be able to support the doorset and holding it rigidly in place, preventing any movement that may occur during the tests. • 5 Type B cycles to be carried out. Each cycle shall consist of the latch of lockset unlatching (with its level handle completing at 900 angle movement), followed by the door leaf opening to 900 angle and then by the closing of the door leaf and finally latching in place. During each cycle, the lockset shall be able to latch fully. • After the 5 Type B cycles, 1 Type A cycle to be performed. The type A cycle is a 900 angle movement of the lever handle of the lockset in locking and unlocking the doorset. During each cycle, the lockset shall fully engage the bolts onto the door frame, with the lever handle completing the full cycle of operation without straining. • This pattern of 5 Type B cycles followed by 1 Type A cycle is to be repeated 10,000 times. <p><u>After completion of 60,000 cycles</u></p> <ul style="list-style-type: none"> • After the test, the doorset shall be checked manually that it is still able to lock in place without causing any strains and all functions of the lockset shall still operate. • Check that there shall be no damages or evidence of undue wear or loosening of any parts of the doorset including the hardwares installed or other defects that may impair its reliability of functioning and the test leaf shall remain connected to the frame. • Check that the lockset's spring bolt through the striking plate shall continue to function correctly and be able to return to its normally

		<p>extended position under its own spring pressure and all functions of the lockset shall still operate.</p> <ul style="list-style-type: none"> • Check for visible cracking or breakage of any components on the hinges and check that the doorset is capable of closing properly, maintaining all clearances between leaf to frame and floor as measured before the test.
2	Water-tightness test	Water tightness test shall be carried out on the door leaf and frame assembly in their closed position. The enclosure formed by the door leaf and frame assembly in their closed position shall be filled with water to a uniform depth of 25mm of water for a period of 2 hours. There shall be no seepage of water within this period.
3	Production test	Dimensional checks in accordance to approved drawings. The door frame can be double rebated to facilitate the installation of a fire door.
4	CED/Galvanised Coating Test	<p><u>CED</u></p> <ul style="list-style-type: none"> • ASTM D3359 <ul style="list-style-type: none"> - Rating 5B (no removal of coating). • SS5 : Part F2 <ul style="list-style-type: none"> - The coating shall withstand test load of 2000g. • ASTM 3363 <ul style="list-style-type: none"> - 2H shall be the hardest pencil that does not scratch the film. • SS5 : Part B1 <ul style="list-style-type: none"> - Dry film thickness shall be 20 ± 5µm. • SS5 : Part G1. Test duration = 500 hours <ul style="list-style-type: none"> - The coating may have any quantity of Size 2 blisters but shall have no more than Density 2 Size 3 blisters as illustrated in ISO 4628-2. - Degree of rusting shall not be more than scale Ri 2 according to ISO 4628-3. • SS5 : Part G6. Test duration = 500 hours <ul style="list-style-type: none"> - The coating shall have no more than Density 2 Size 2 blisters as illustrated in ISO 4628-2. - Degree of rusting shall not be more than scale Ri 1 accordingly to ISO 4628-3. <p><u>Electro-galvanised</u></p> <ul style="list-style-type: none"> • ASTM A90 <ul style="list-style-type: none"> - Coating thickness = 3.5 microns minimum.
5	Rubber gasket test	ASTM D1056 (Grade 2A3, 2A4, 2A5, 2B3, 2B4 or 2B5)

c. Documents Submitted for New CoC Applications

The following documents shall also be submitted for CoC applications:

- i. Test reports, including the full type test reports and other test(s) required by the CB (e.g. material tests), which shall be:
 - a. In full colour.
 - b. Bear the brand and model of the regulated shelter product.
- ii. For each test report, the credentials of the accredited laboratory which issued the test report, including:
 - a. Documentation that the test laboratory is accredited by SAC or recognised by SAC via ILAC MRA.
 - b. The accreditation scope indicating the test laboratory is accredited to perform such a test.

d. Information and Documents Submitted for Renewal of CoC

CoC holders shall submit the information stipulated in [Clause 8.3.5b](#)(1) and (2) and provide the date of issue of the very first CoC that had been issued for the product (i.e. "Original date of issue"). The CB shall make an assessment on whether there is a need to submit information stipulated in [Clause 8.3.5b](#)(3) – (5), as well as documents stipulated in [Clause 8.3.5c](#)(1) and (2). CB may require submission of any further information/documents as it deems fit.

CLAUSE 8.4 SERIAL LABELS

8.4.1 Traceability of Certified Shelter Products

a. Serial labels affixed to certified shelter products shall be water -proof and tamper-proof, and shall include a Quick Response (QR) code that stores the following information on an online database, which can be read by scanning the QR code:

- i. CoC holder company name.
- ii. CoC holder ACRA UEN.
- iii. CoC reference number
- iv. Brief product description.
- v. Exact location, including unit number, where applicable, where the regulated shelter product is installed.
- vi. The status of the label (“valid” or “void”).

Note: The status of the label will be ‘void’ if SCDF detects discrepancies relating to the use of serial labels and digitally voided the serial label.

b. The following information shall be printed on the label itself:

- i. Product category.
- ii. Unique serial number.
- iii. CB’s logo or CB’s certification mark.

8.4.2 Replacement of Serial Labels

a. The following information shall be printed on the label itself:

b. An investigation by the CB shall also be conducted on the nature of the damage and/or loss, with the findings reported to SCDF for accountability.

Exemption: If labels are returned to the CB with the serial numbers still legible, a police report is not required.

CLAUSE 8.5 REQUIREMENTS AND RESPONSIBILITIES FOR QUALIFIED PERSONS

Where shelter works involve the use of regulated shelter products, Qualified Persons shall carry out inspections of the shelter products, including but not limited to, the following:

- Verify that the regulated shelter product(s) have valid CoC(s) and that the CoC(s) match exactly with the products used.
- Verify that the regulated shelter product(s) are affixed with serial labels, if said products are stipulated to have labels in Table 8.1.
- Where there are serial labels, verify that the serial label affixed on the product, are accurate and match exactly with the product.

Figures & Tables

TABLE 8.1 : LIST OF REGULATED SHELTER PRODUCT

PRODUCTS	ACCEPTABLE STANDARDS	CERTIFICATION SCHEME	SURVEILLANCE REGIME	
			TESTING	FACTORY AND SITE INSPECTION
Storey Shelter Door	Refer to Table 8.2	Scheme 5 (Label issued)	Once every 3 years for cyclic test. Annually for water tightness test, dimension check, CED coating test & rubber gasket test.	At least once annually or by trigger (every 200 labels).

TABLE 8.2: TEST STANDARDS AND SPECIFICATIONS FOR STOREY SHELTER DOOR

TYPE TESTS – SCHEME TYPE 5		
S/N	TEST	STANDARD/SPECIFICATION
1	Door locking mechanism cyclic test (Once in 3 years)	<p><u>Test Cycles</u></p> <p>The entire test shall consist of 60,000 cycles, which in turn comprise two cyclic types:</p> <ul style="list-style-type: none"> Type A : 10,000 in Civil Defence (CD) mode when the lock bolts are activated. Type B : 50,000 for normal opening and closing of door (based on 900 angle of opening function). <p>(Note: Type A cycles are to be performed interspersed between the Type B cycles in the ratio 1:5, i.e. 1 Type A cycle to be done after every 5 Type B cycles.)</p> <p><u>Test Method and Requirements</u></p> <ul style="list-style-type: none"> The test is conducted using the test rig designed to be able to support the doorset and holding it rigidly in place, preventing any movement that may occur during the tests. 5 Type B cycles to be carried out. Each cycle shall consist of the latch of lockset unlatching (with its level handle completing at 900 angle movement), followed by the door leaf opening to 900 angle and then by the closing of the door leaf and finally latching in place. During each cycle, the lockset shall be able to latch fully. After the 5 Type B cycles, 1 Type A cycle to be performed. The type A cycle is a 900 angle movement of the lever handle of the lockset in locking and unlocking the doorset. During each cycle, the lockset shall fully engage the bolts onto the door frame, with the lever handle completing the full cycle of operation without straining. This pattern of 5 Type B cycles followed by 1 Type A cycle is to be repeated 10,000 times. <p><u>After completion of 60,000 cycles</u></p> <ul style="list-style-type: none"> After the test, the doorset shall be checked manually that it is still able to lock in place without causing any strains and all functions of the lockset shall still operate. Check that there shall be no damages or evidence of undue wear or loosening of any parts of the doorset including the hardwares installed or other defects that may impair its reliability of functioning and the test leaf shall remain connected to the frame. Check that the lockset's spring bolt through the striking plate shall continue to function correctly and be able to return to its normally extended position under its own spring pressure and all functions of the lockset shall still operate. Check for visible cracking or breakage of any components on the hinges and check that the doorset is capable of closing properly, maintaining all clearances between leaf to frame and floor as measured before the test.
2	Water-tightness test	Water tightness test shall be carried out on the door leaf and frame assembly in their closed position. The enclosure formed by the door leaf and frame assembly in their closed position shall be filled with water to a uniform depth of 25mm of water for a period of 2 hours. There shall be no seepage of water within this period.
3	CED/Galvanised Coating Test	<p><u>CED</u></p> <ul style="list-style-type: none"> ASTM D3359 - Rating 5B (no removal of coating). SS5 : Part F2 - The coating shall withstand test load of 2000g. ASTM 3363 - 2H shall be the hardest pencil that does not scratch the film. SS5 : Part B1 - Dry film thickness shall be 20 ± 5µm SS5 : Part G1. Test duration = 500 hours - The coating may have any quantity of Size 2 blisters but shall have no more than Density 2 Size 3 blisters as illustrated in ISO 4628-2. - Degree of rusting shall not be more than scale Ri 2 according to ISO 4628-3. SS5 : Part G6. Test duration = 500 hours - The coating shall have no more than Density 2 Size 2 blisters as illustrated in ISO 4628-2. - Degree of rusting shall not be more than scale Ri 1 accordingly to ISO 4628-3. <p><u>Electro-galvanised</u></p> <ul style="list-style-type: none"> ASTM A90 - Coating thickness = 3.5 microns minimum.
4	Rubber gasket test	ASTM D1056 (Grade 2A3, 2A4, 2A5, 2B3, 2B4 or 2B5).
SURVEILLANCE TESTS – SCHEME TYPE 5		
1	Door locking mechanism cyclic test	<u>Test Cycles</u>

		<p>The entire test shall consist of 60,000 cycles, which in turn comprise two cyclic types:</p> <ul style="list-style-type: none"> • Type A : 10,000 in Civil Defence (CD) mode when the lock bolts are activated. • Type B :: 50,000 for normal opening and closing of door (based on 90° angle of opening function). <p>(Note: Type A cycles are to be performed interspersed between the Type B cycles in the ratio 1:5, i.e. 1 Type A cycle to be done after every 5 Type B cycles.)</p> <p><u>Test Method and Requirements</u></p> <ul style="list-style-type: none"> • The test is conducted using the test rig designed to be able to support the doorset and holding it rigidly in place, preventing any movement that may occur during the tests. • 5 Type B cycles to be carried out. Each cycle shall consist of the latch of lockset unlatching (with its level handle completing at 90° angle movement), followed by the door leaf opening to 90° angle and then by the closing of the door leaf and finally latching in place. During each cycle, the lockset shall be able to latch fully. • After the 5 Type B cycles, 1 Type A cycle to be performed. The type A cycle is a 90° angle movement of the lever handle of the lockset in locking and unlocking the doorset. During each cycle, the lockset shall fully engage the bolts onto the door frame, with the lever handle completing the full cycle of operation without straining. • This pattern of 5 Type B cycles followed by 1 Type A cycle is to be repeated 10,000 times. <p><u>After completion of 60,000 cycles</u></p> <ul style="list-style-type: none"> • After the test, the doorset shall be checked manually that it is still able to lock in place without causing any strains and all functions of the lockset shall still operate. • Check that there shall be no damages or evidence of undue wear or loosening of any parts of the doorset including the hardwares installed or other defects that may impair its reliability of functioning and the test leaf shall remain connected to the frame. • Check that the lockset's spring bolt through the striking plate shall continue to function correctly and be able to return to its normally extended position under its own spring pressure and all functions of the lockset shall still operate. • Check for visible cracking or breakage of any components on the hinges and check that the doorset is capable of closing properly, maintaining all clearances between leaf to frame and floor as measured before the test.
2	Water-tightness test	Water tightness test shall be carried out on the door leaf and frame assembly in their closed position. The enclosure formed by the door leaf and frame assembly in their closed position shall be filled with water to a uniform depth of 25mm of water for a period of 2 hours. There shall be no seepage of water within this period.
3	Production test	Dimensional checks in accordance to approved drawings. The door frame can be double rebated to facilitate the installation of a fire door.
4	CED/Galvanised Coating Test	<p><u>CED</u></p> <ul style="list-style-type: none"> • ASTM D3359 - Rating 5B (no removal of coating). • SS5 : Part F2 - The coating shall withstand test load of 2000g. • ASTM 3363 - 2H shall be the hardest pencil that does not scratch the film. • SS5 : Part B1 - Dry film thickness shall be $20 \pm 5\mu\text{m}$. • SS5 : Part G1. Test duration = 500 hours - The coating may have any quantity of Size 2 blisters but shall have no more than Density 2 Size 3 blisters as illustrated in ISO 4628-2. - Degree of rusting shall not be more than scale Ri 2 according to ISO 4628-3. • SS5 : Part G6. Test duration = 500 hours - The coating shall have no more than Density 2 Size 2 blisters as illustrated in ISO 4628-2. - Degree of rusting shall not be more than scale Ri 1 accordingly to ISO 4628-3. <p><u>Electro-galvanised</u></p> <ul style="list-style-type: none"> • ASTM A90 - Coating thickness = 3.5 microns minimum.
5	Rubber gasket test	ASTM D1056 (Grade 2A3, 2A4, 2A5, 2B3, 2B4 or 2B5)

Clause No.	Amendment Date	Effective Date	Clause Status	Clause Before Amendment	Circular Date
------------	----------------	----------------	---------------	-------------------------	---------------