

CHAPTER 2

OFFICE, SHOP AND PLACE OF PUBLIC RESORT

2.1 GENERAL

- 2.1.1 The provisions of this chapter of the Code shall serve to express the intentions for determining the design, construction, protection, location, arrangement and maintenance of exit facilities to provide safe means of escape for occupants from all buildings hereafter erected, altered or changed in occupancy.

This chapter focuses on illustrating the intentions stated above for occupants of all buildings of Purpose Group IV, V and Purpose Group VII. Example of Purpose Group IV buildings are office premises, and examples of Purpose Group V buildings are shops, departmental stores, supermarkets, shopping arcades, drug stores and etc. Whereas, examples of Purpose Group VII buildings are premises used for social, recreational or business purposes such as, hotels, holiday resorts, boarding houses, convention centres, private clubs, community centres, theatres, airports and etc.

The provision of fire escape in buildings under Purpose Groups IV, V & VII comprises 3 distinct parts;

- (a) The part within the functional room spaces to the exit staircase/area of refuge;*
 - (b) The exit staircase; and*
 - (c) The exit discharge.*
- (a) The part within the functional room spaces to the exit staircase/area of refuge.*

It is critical that occupants from their respective areas of occupancy are able to get out within a prescribed distance, should a fire break out. The prescribed distances (given in Table 2.2A) shall be measured from the most remote point in that room space to its entrance (on first storey), or to the nearest exit staircase door, serving that storey or to door of area of refuge.

Occupants in room spaces, provided with two or more exit doors, should ensure that all these doors are readily opened for escape in emergency situations.

(b) *The exit staircase*

Once the occupants have entered the exit staircase, they shall be protected (from exposure to fire risk and obstacle) throughout their descent down the staircase to the final exit at ground level.

(c) *The exit discharge*

Occupants exiting from the exit staircases shall be able to discharge into the open external space at the ground level. From this point on they should no longer be in any danger from the fire or smoke in the building.

Where an exit opens or discharges into an internal courtyard, a safe passageway must be readily available to lead the occupants out from this internal courtyard to safety at the building exterior.

Examples on the detailed workings in deriving the total number of and widths of exit doorways and staircases, applying the above steps are furnished herewith as Attachment 1 which can be found at the end of the chapter.

Staircase Identification

Staircase identification is required for all buildings (except Purpose Group 1) irrespective of the height of the building.

Staircase identification is to facilitate fire fighting operation. It also enables the user of the staircase to orientate his location or whereabouts. This would help to alleviate any fear of disorientation by a person using the staircase during a fire emergency.

Requirement on Stairway numbering system

(a) *The Numbering System is composed of square signs of at least 30cm x 30cm located, or painted, on the wall surface adjacent to the door on the stairway side.*

(b) *A sign should be located at each level landing in the stairway. The bottom of the sign should be located not less than 1.5m above the floor of the staircase landing. The sign should be placed adjacent to the door and shall be visible with the door opened or closed.*

(c) *The block-lettered sign may be of any colour that will contrast with the colour scheme of the stairway.*

(1) *The height of the large number(s) in the middle of the sign denoting the storey should be a minimum of 12.5cm.*

Location of sign in staircase

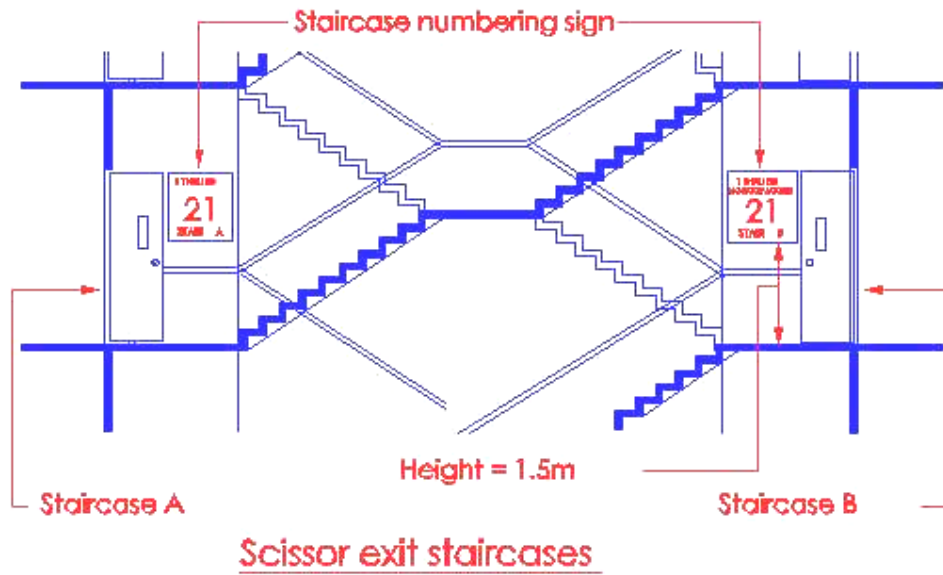
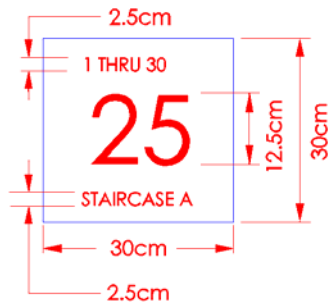

Diagram 2.1.1 - 1



EXAMPLE 1

25th storey of a staircase that extends from the 1st storey to the 30th storey of a 30-storey building. The staircase terminates at the roof.

This is the 'A' staircase in the building.

Diagram 2.1.1 - 1a

2.1.1
Cont'd

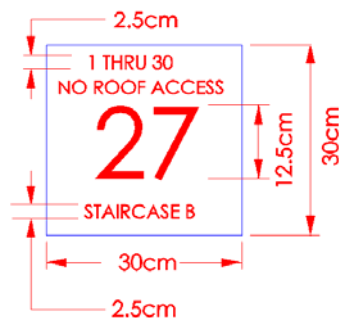

EXAMPLE 2

27th storey of a staircase that extends from the 1st storey to the 30th storey of a 30-storey building. The staircase does not provide access to the roof.

This is the 'B' staircase in the building.

Diagram 2.1.1 - 1b

- (2) The number(s) and/or letter(s) at the top of the sign denoting the upper and lower terminations of the stairway should be a minimum of 2.5cm.

Staircases that extend to the topmost storey of the building should have 2.5cm minimum height letters stating "NO ROOF ACCESS" on the sign below the upper storey designation.

Staircases in the building should be consecutively indicated in alphabetical order. The lettering height should be 2.5cm minimum, e.g., Staircase A, and located at the bottom of the sign.

Fire Escape Plan

Fire escape plan is to be provided for all buildings (except Purpose Group 1) irrespective of height.

A fire escape plan is for use by the public and occupants in case of a fire as well as for the fire fighters. A good fire escape plan should therefore be clearly visible, with legible lettering and the fire escape route made clear to the readers. It should clearly show the layout of the floor in the correct building orientation and highlight the escape routes (in relation to viewer's location), escape corridors and exit staircases using appropriate colours, directional signs and words. Other information required on the plan are for fire fighting purposes and these include the following;

- (1) Firemen's lift
- (2) Hosereels
- (3) Extinguishers
- (4) Dry and wet risers
- (5) Fire indicator board
- (6) Manual alarm call points

These plans should be placed at common area locations in such buildings where the public and occupants of the building are most likely to frequent or use. Such locations can include the common corridors, lobbies/lift lobbies (if available) and staircases. These plans should be placed at locations such that the general public can locate them immediately when moving through these common areas.

Air supported structure

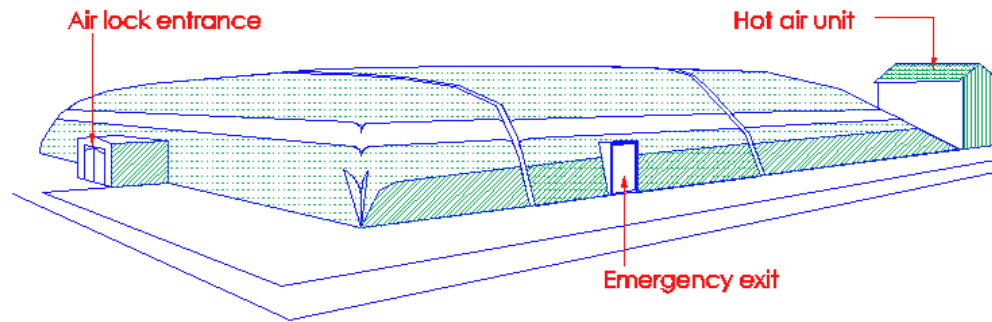

Diagram 2.1.1 – 2

- a) *There are various types of air supported or pneumatic building. Air supported structures are used for commercial and industrial applications, such as dining area, warehousing and manufacturing processes, for the agricultural and horticultural industries etc.*
- b) *The membrane used for the air supported structures are usually nylon, plastic, PVC or polythene sheet material, which are combustible in a fire.*
- c) *The main concerns are :*
 - (i) *the likelihood of the collapse of the roof owing to lack of pressure inside the structure or during times of emergency;*
 - (ii) *the combustibility of the structure itself; and*
 - (iii) *the collapse of the roof may cause panic and difficulties to occupants escaping during times of emergency.*
- d) *In view of the above, proposal for air supported structure shall be evaluated separately and SCDF (FSSD)'s consent shall be obtained before making building plan submission.*

2.2 DETERMINATION OF EXIT REQUIREMENTS

2.2.1 General

The determination of exit requirements for a building shall be based upon the type of use or occupancy of the building, the occupant load, the floor area, the travel distance to an exit and the capacity of exits as provided in Table 2.2A and herein. Every storey of a building shall be provided with exit facilities for its occupant load. Vertical exits provided from any storey above ground level may serve simultaneously all storeys above the ground level and vertical exits provided from any storey below ground level may serve all storeys below ground level, subject to the provisions of Cl. 2.3.5 which prohibit basement staircases being continuous with exit staircases serving the upper storeys, unless otherwise allowed by the Relevant Authority.

The process on how to determine the number of and adequacy of exit facilities from a given space or a storey of a building will be explained herewith. Schedules 4, 5 & 7.1 to 7.10, and Table 2.2A as given in the Fire Code will be referred to.

The Cl.2.3.5 referred here covers requirements pertaining to the non-continuity, or separation, of exit staircases serving upper storeys from that serving the basement storeys of a building. Its details and the conditions for exemptions, if any, will be illustrated under the Cl.2.3.5.

Determining number and capacity of exit facilities

It is very essential that the building designers establish the number, sizes and capacity of exit facilities, especially that of exit doorways and exit staircases, to ensure their adequacy in facilitating the evacuation of all the occupants from that building during an emergency.

To determine the number and adequacy of exit doorways and staircases from a building or storey of a building, the following 3 steps may be taken:

- (1) Determine the occupant load, OL, on each storey of the building. This means computing the total number of persons that could be 'accommodated' in all spaces on a storey of the building. This is done on a storey by storey basis.*
- (2) Determine the number of 'unit of width' of exit required facilitating escape for the above OL from each storey of that building. Clause 2.2.5 shall be referred for the explanation and application of the 'unit of width' for exit computation.*

- (3) Determine the number of and the minimum widths of the exit doors and exit staircases required facilitating escape for that OL on each storey of that building.

Examples on the detailed workings in deriving the total number of and widths of exit doorways and staircases, applying the above steps are furnished herewith as Attachment 1, which can be found at the end of the chapter.

2.2.2 Mixed Occupancy

Where different parts of a building or storey of a building are designed for different types of occupancies or used for different purposes at the same time, the exit requirements of the entire building or storey of the building shall be determined on the basis of that type of occupancy or usage having the strictest exit requirements or the exit requirements for each building section shall be determined separately.

- (1) *Travel distance requirement:-*

For a storey of mixed occupancy building consisting of offices, shops and place of public resort, the exit capacity of staircases may be based on the total of the occupancies computed separately for each usage type as per schedules 4, 5 and 7. However the position of the exit staircases shall be so located that the maximum permissible travel distance from any remote point to the staircase shall be based on that of the shop, having the stricter requirements in Table 2.2A. That is, maximum 45m two-way escape travel distance for non-sprinkler protected buildings and 60m two-way escape travel distance for sprinkler protected buildings shall be applicable and not the 45m and 75m distances allowable for office developments. Hence:

Travel distance (dotted in diagram 2.2.2 – 1) to the nearest exit staircase shall not exceed 30m or 60m (if sprinkler protected).

The Direct distance to the nearest exit staircase, if there are no predetermined walls, shall not exceed 30m ($\frac{2}{3} \times 45\text{m}$) or 40m ($\frac{2}{3} \times 60\text{m}$, if sprinkler protected).

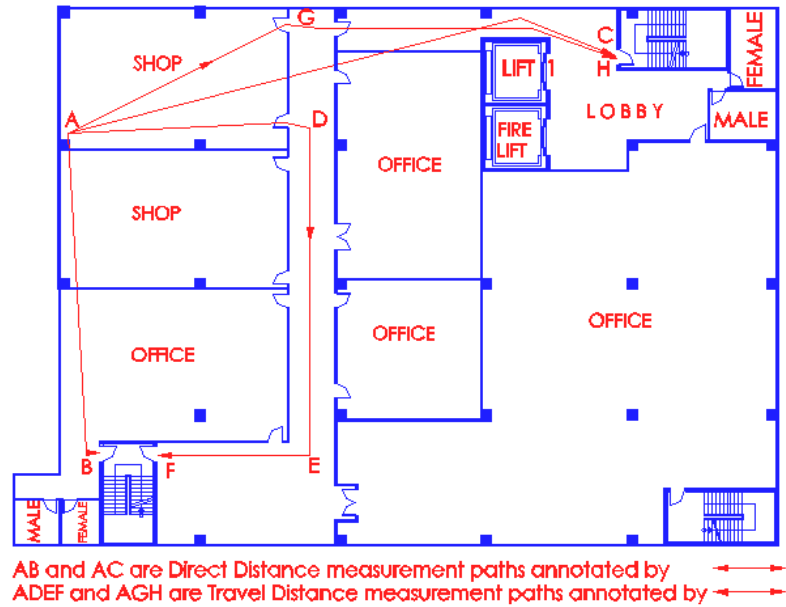

Diagram 2.2.2 - 1

The exit provisions in a mixed development may be assessed and provided separately if the differing purpose types are clearly defined and compartmentalized.

For example, the escape distances for the offices' area, which is clearly located in one part of the building as shown in diagram 2.2.2 – 2, may be based on the office configurations given in Table 2.2A. The remaining part of the building with the shopping usage is then based on the shop configurations.

EXAMPLE OF SEPARATE TRAVEL DISTANCE APPLICATION

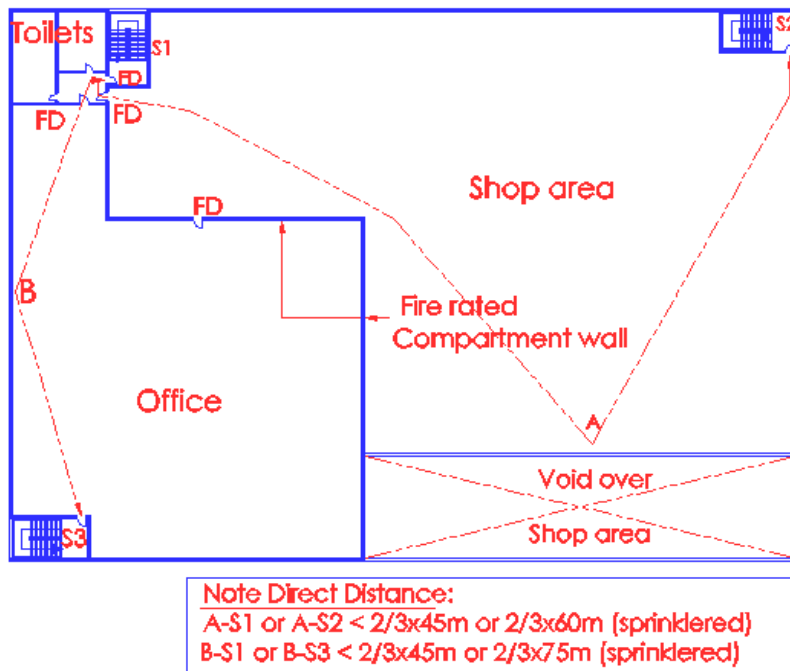

Diagram 2.2.2 – 2

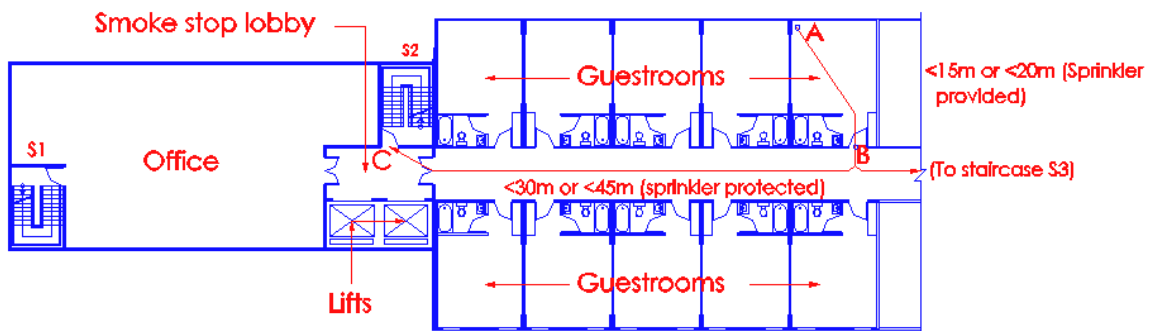

Diagram 2.2.2 – 3

(2) Exit requirement:-

Buildings with mixed occupancies the exit capacity of its exit staircases shall be based on the type of occupancy or usage having the strictest exit requirements given in Table 2.2A.

For example, see diagram 2.2.2 -3

A storey of a building comprises office and hotel residential occupancy separated by compartment walls, but shares common facilities like the staircases and lifts.

Then the exit capacity of its shared staircase (staircase S2) shall be based on the most stringent type of mixed occupancies, i.e. hotel residential floors.

Office occupancy (Staircase S1)

Number of persons per unit of exit width (500mm) of staircase = 60 persons.

Hotel residential occupancy (Staircase S2 & S3)

Number of persons per unit of exit width (500mm) of staircase = 30 persons.

Mixed Development with Office/Shop And Restaurant Sharing Common Exit Staircases

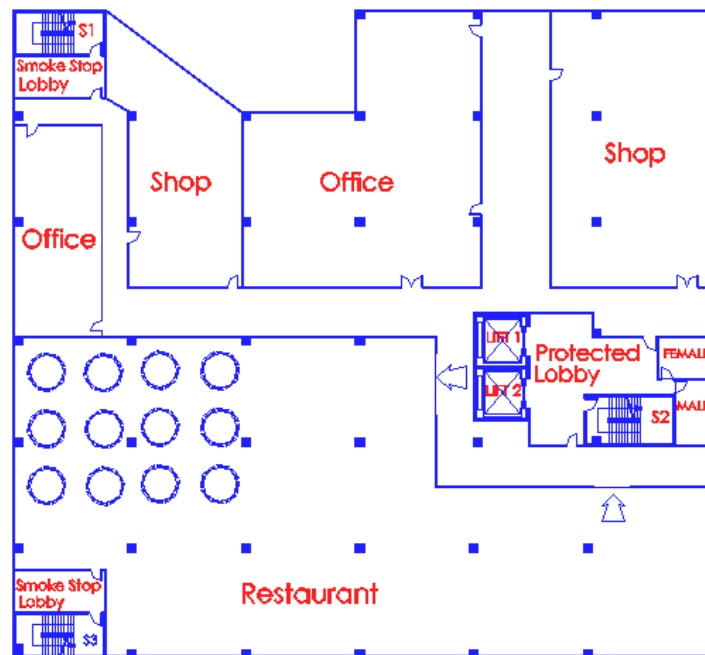

Diagram 2.2.2 - 4

The above diagram illustrates a mixed occupancies of office, shop and restaurant sharing common exit staircases (S1 & S2).

In the case of restaurant, the maximum permissible occupant load can be based on the capacity of the three staircases. As Staircase S3 is for the exclusive use of restaurant, owing to its location, this staircase is inaccessible to occupants from offices and shops. Therefore, Staircase S3 shall not be computed as a common exit staircase rather computed as exit staircase for restaurant only.

i.e.:

$$\begin{aligned} \text{Exit capacity of common staircases} &= 4 \text{ units} \times 60 \text{ persons} \times 2 \text{ staircases} \\ \text{(Staircases S1 \& S2 of 2m width each)} &= 480 \text{ persons} \end{aligned}$$

Hence, each common exit staircase can accommodate 240 persons (½ of 480 persons)

It is acceptable to allow ½ the occupant load of restaurant to use Staircase S3 and the other ½ to use the common exit staircases S1 & S2. Therefore, the maximum permissible occupant load for shops and offices shall include ½ the occupant load of restaurant, subject to not exceeding a total of 480 persons.

Situation where the exit capacities of entire staircase on all storeys are accounted similarly

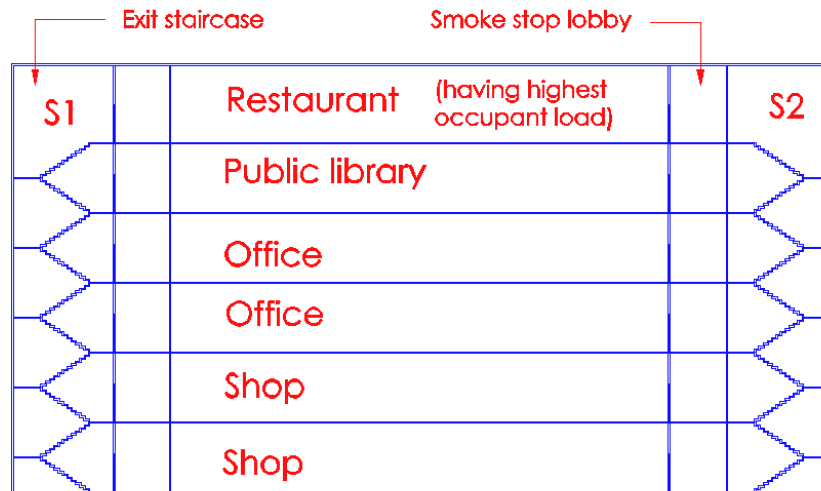

Diagram 2.2.2 - 5

The strictest capacity of staircase exit width (applicable to restaurant) shall be applicable to all levels or storeys of the building with such shared staircase arrangement. This is regardless of the restaurant being located on the second storey or the top most storey of a multi-storey building.

2.2.3 Multiple occupancy or use

Where a building or storey of a building or a part of a building is used for multiple purposes involving different activities at different times, that purpose or use involving the greatest number of occupants shall form the basis for determining the exit requirements.

A Multipurpose Hall is an example of a space with multiple occupancy or use. It may have the various uses as listed below. Its exit provisions shall be based on the usage with the greatest occupant load. In this case it should cater to that of the dance hall, being the most stringent basing on an area of 1m² per person.

Examples of usage of multipurpose hall:-

- * Sports gym
- * Dinner / buffet functions
- * Exhibitions / seminars
- * Church assembly
- * Lecture hall / classroom
- * Dance hall

2.2.3

Example of building with a Multiple usage storey

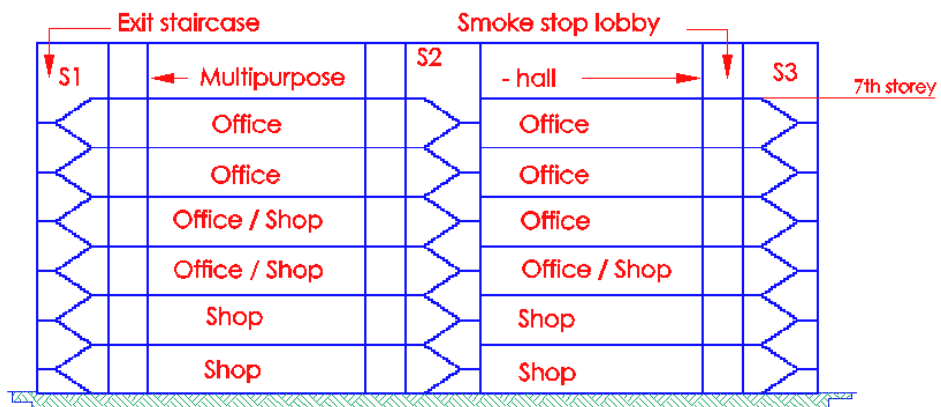

Diagram 2.2.3 - 1

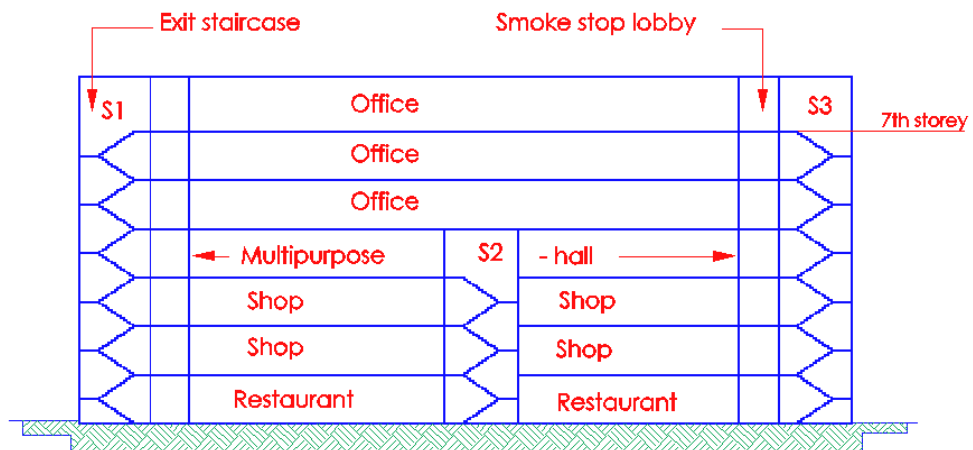

Diagram 2.2.3 - 2

In diagram 2.2.3 - 1, the multipurpose hall located on the 7th storey would have the highest occupant load. Hence, adequate number of exit staircases required to accommodate the evacuation of its occupant load shall be provided to the building. The total exit capacity of its exit staircases shall be determined based on its usage with the highest density of people. The exit staircases shall be carried right down to the ground level without any reduction in its width, regardless of the lower storeys having less number of occupants.

On the other hand, if the multipurpose hall is located on an intermediate storey, then the exit requirements or provisions based on its usage should be applicable to the entire storey including the storeys below it.

2.2.4 Non-simultaneous occupancy

The floor areas of toilets, locker rooms, storage rooms, staff canteens, lobbies, corridors and similar rooms and spaces that serve other rooms and spaces on the same storey but are not occupied at the same time as such other rooms or spaces, may be omitted from the occupant load calculations of that storey of the building on which they are located.

It is to be noted that the staff canteens, though inadvertently included in this clause, is to be treated as simultaneous occupancies as reflected in the schedules. This is due to the nature of its usage, whereby the public or staff from other levels of the building would be patronizing it. Pantries, on the other hand, provided in the various levels of offices catering to specific groups of staff, may be treated as non-simultaneous areas. Hence, in applying the above clause, building owners have to be certain that such rooms or spaces are not accessible by the public.

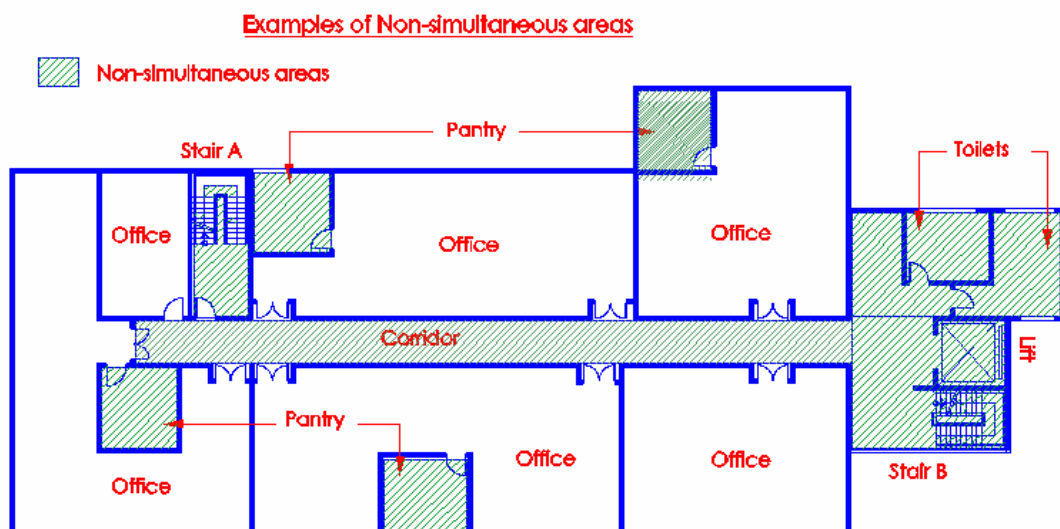
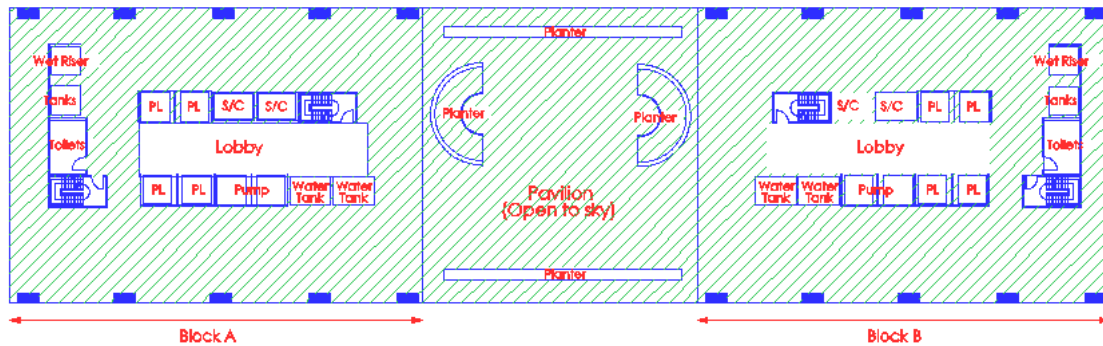

Diagram 2.2.4- 1

Examples of Non-simultaneous areas



20th storey



The communal floor space intended for non-residential use shall be subjected to occupant load calculation.

Diagram 2.2.4- 2

Diagrams 2.2.4-1 & 2 show examples of areas that may be treated as non-simultaneous areas that may be exempted from computation of the occupant load for that storey of the building.

2.2.5 Capacity of exits and exit facilities

The capacity of exits, exit staircases, exit passageways, corridors, exit doors and other exit facilities shall be measured in units of width of one half of a metre. The type of occupancy and type of exit as listed under Table 2.2A shall determine the number of persons per unit of width. In the determination of each exit width, fractions of a unit width less than 250 mm shall not be credited. Where 250 mm or more are added to one or more full units, half of a unit of width shall be credited.

Where a room or space is required to be provided with two exits, each exit shall be of sufficient width to accommodate not less than one half the total occupant load.

To prevent overcrowding one has to ensure that the corridor and the exit staircases serving a storey of a building are adequate in size to receive all the occupants on that floor at the time of evacuation.

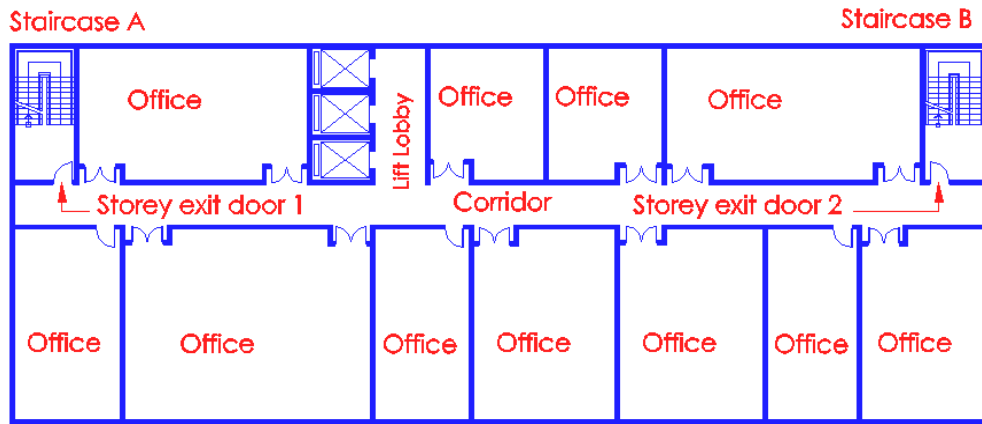

Diagram 2.2.5-1

The capacity of exit doors to room, corridor, exit doors to staircases and exit staircases are measured in units of width of one half of a metre i.e.:

Clear width of exit door/corridor/staircase	Number of unit widths
1m	2
1.5m	3
2m	4

Where a fraction of 250mm or more are added to one or more full units, half of a unit of width shall be credited, for example:

Clear width of exit door/corridor/staircase (mm)	Number of unit widths
1000 to 1249	2
1250 to 1499	2.5
1500 to 1749	3
1750 to 1999	3.5
2000 (maximum)	4 (maximum number per exit)

The number of persons per unit of width shall be determined by the type of occupancy and type of exit as listed under Table 2.2A of the Fire Code.

Example 1;

Office/Shop/Places of public resort:

1 unit width = 500mm = 60 and 80 persons per unit width through staircase and doorway respectively.

This means that 1m of doorway of the above development permits the passage of 160 persons, while 1m of its staircase permits the passage of only 120 persons per storey. The difference in the number of person per unit width is due to the difference in speed of movement over a level plane as against that down a staircase. It shall be noted here that these are computed per storey basis. For hotel residential occupancy, 1 unit width = 500mm =30 persons.

Acceptable – Even distribution of exit capacity

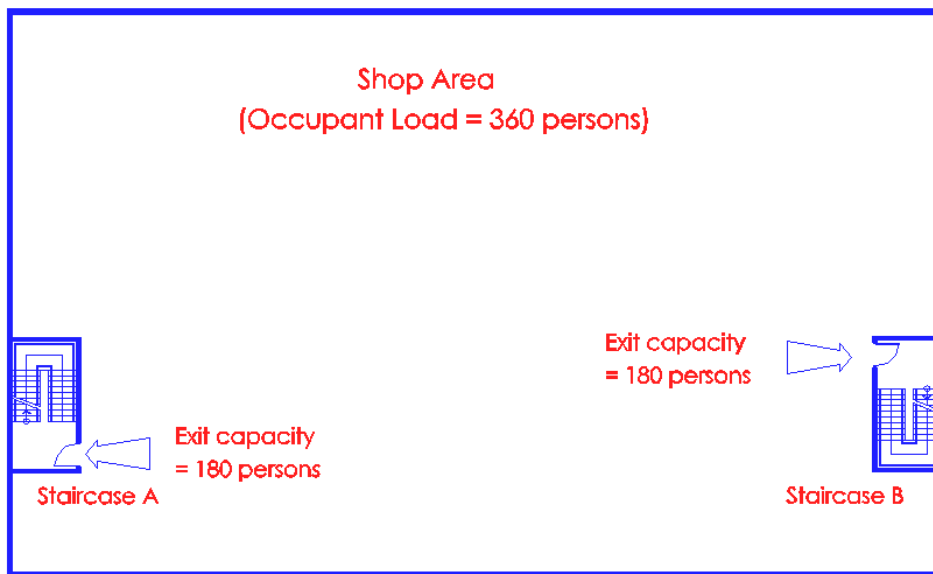

Diagram 2.2.5 – 2

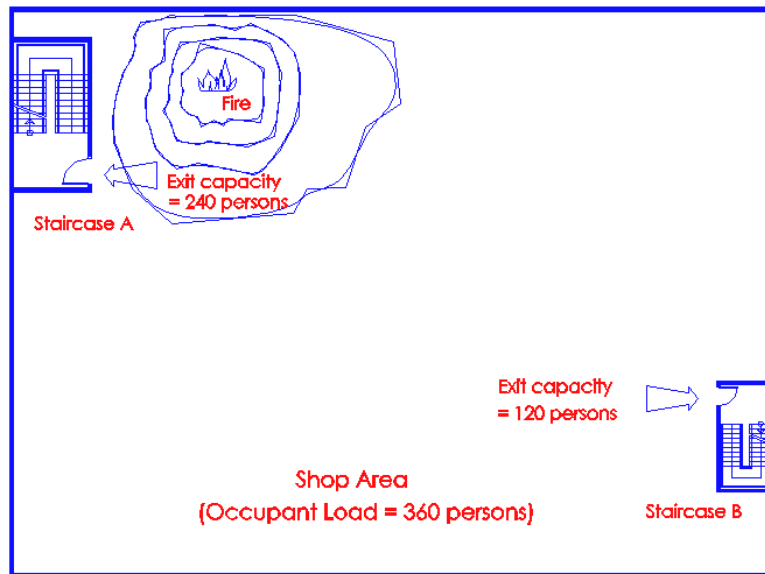

Diagram 2.2.5 – 3

- 2.2.5 The above sub-clause is to address the problem, which may arise if staircases are not proportionately sized and distributed. For example, a fire near Staircase A in diagram 2.2.5 – 3, which is designed to facilitate escape for 240 persons, can render it inaccessible. This would mean that, the other exit, Staircase B, which is only designed for 120 persons' escape, would thence need to facilitate escape for the full occupant load of 360 persons from that storey.

This scenario would render Staircase B to be drastically inadequate to facilitate the timely escape of all the occupants, before the fire and smoke engulfs the entire floor space. This is because it would require three times as long to evacuate the occupants from that storey using only Staircase B.

2.2.6 Determination of travel distance

The maximum travel distance for the respective types of occupancies shall be not greater than as laid down in Table 2.2A read in conjunction with the following:

- (a) In the case of a floor area designed with minimum two exits, the maximum travel distance as given in Table 2.2A shall be applicable. The maximum travel distance starting from the most remote point in any occupied space to the nearest exit, shall not exceed the limits specified in Table 2.2A, and

Not acceptable

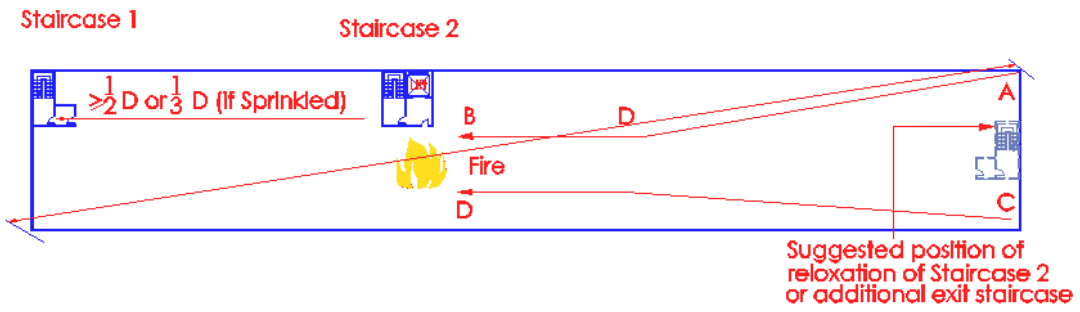

Diagram 2.2.6(a) - 1

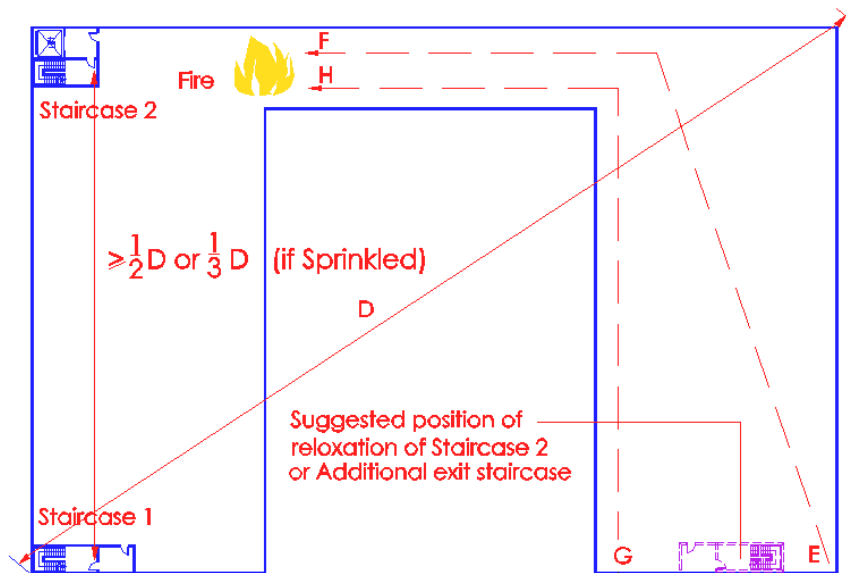

Diagram 2.2.6(a) - 2

In the above diagrams, the exit staircases are not remotely located from each other to reduce the possibility that more than one staircase can be blocked off by fire or other emergency condition. The escape routes AB, CD, EF, and GH are all considered as one-way direct travel as there is no alternative escape route. Occupants escaping in a fire emergency are unable to reach the nearest staircase as the escape routes are blocked by fire. The distribution of the staircases does not meet the intents of CL.1.2.60 of Fire Code '97, which require that "such exits shall be remotely located from each other and shall be arranged and constructed to minimise the possibility that more than one can be blocked by any fire or other emergency condition".

In the above diagrams, direct travel distances, which are highlighted, will be considered as one-way direct travel instead of two-way direct distance travel. To overcome the problems of one-way direct travel, relocation or addition of an exit staircase would be necessary, subject to meeting the direct travel distance requirements.

- 2.2.6 (b) In a large floor area sub-divided into rooms, corridors and so forth, the travel distance requirements of the foregoing paragraphs of this clause shall be deemed to be satisfied if the 'direct distance' does not exceed two-third of the maximum travel distance permitted under Table 2.2A, and

(Note: "travel distance" is to be taken as direct Distance).

Maximum escape distance design parameters

	<u>SPRINKLERED</u>			<u>NON-SPRINKLERED</u>		
	<i>Shops</i>	<i>Offices</i>	<i>Places of public resort</i>	<i>Shops</i>	<i>Offices</i>	<i>Places of public resort</i>
<i>One-way Travel Distance (m)</i>	25	30	25	15	15	15
<i>One-way Direct Distance (m)</i>	16.6	20	16.6	10	10	10
<i>Two-way Travel Distance (m)</i>	60	75	60	45	45	45
<i>Two-way Direct Distance (m)</i>	40	50	40	30	30	30

Typical Storey Plan of Office Building

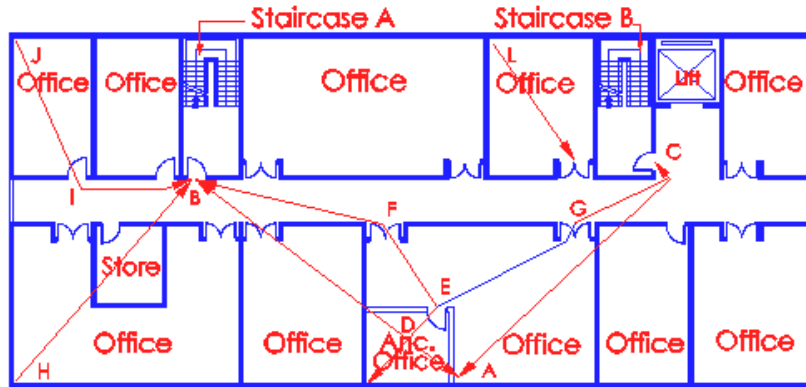

- AB and AC are Two-way Direct Distance measurement paths annotated by ↔
- DEFB and DEGC are Two-way Travel Distance ↔
- HB is One-way Direct Distance →
- Measurement path annotated by →
- JIB is One-way Travel Distance →
- Measurement path annotated by →
- L is one-way Direct Distance [$\frac{2}{3}$ t.d.] →
- Measurement path annotated by (internal partitioning of office space is expected)

Diagram 2.2.6 (a) & (b) – 1

DIRECT DISTANCE = $\frac{2}{3}$ TRAVEL DISTANCE

The actual path that an occupant needs to take from any part of a storey space to the nearest exit door to the external space or exit staircase, will be measured for escape travel distance compliance. This distance takes into account the internal partitions within that floor space and it shall comply with the relevant travel distances stipulated in Table 2.2A.

Thus, where details of the internal layout are furnished in the building plan submissions, for example Diagram 2.2.6 (a) & (b) –1, the full travel distances permissible under the Table 2.2A would be applied.

However, in most situations during the planning and building plan submission stages of a building, the designer is unable to confirm the internal layout of the storey spaces. It is recommended that the direct distance measurements, which is two thirds of the allowable travel distances, should be applied to such 'open' layout plans.

Example:

Typical single tenancy single office storey

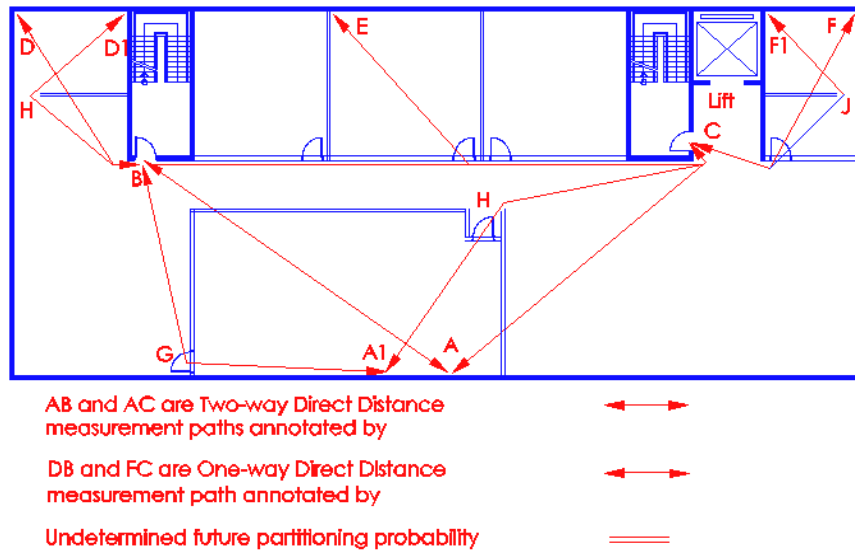

Diagram 2.2.6 (a) & (b) – 2

The dotted walls in diagram 2.2.6(a) & (b) - 2, for example, may not be shown on plan. In such indefinite situation, a straight line drawn from the most remote point A to B or C shall be taken as the two-way direct distance. If the maximum permissible two-way travel distance given in Table 2.2A for such usage is 75m (sprinklered), the direct distances (straight lines AB or AC) shall not exceed 50m, i.e. $\frac{2}{3} \times 75\text{m}$. This shall also apply to the one-way direct distances BD and CF, as the actual one-way travel distances could possibly be D1HB and F1JC.

This application of the direct distance measurements, besides facilitating flexibility for future inclusions and changes in layout, ensures that escape distances for the occupants would not subsequently be excessive.

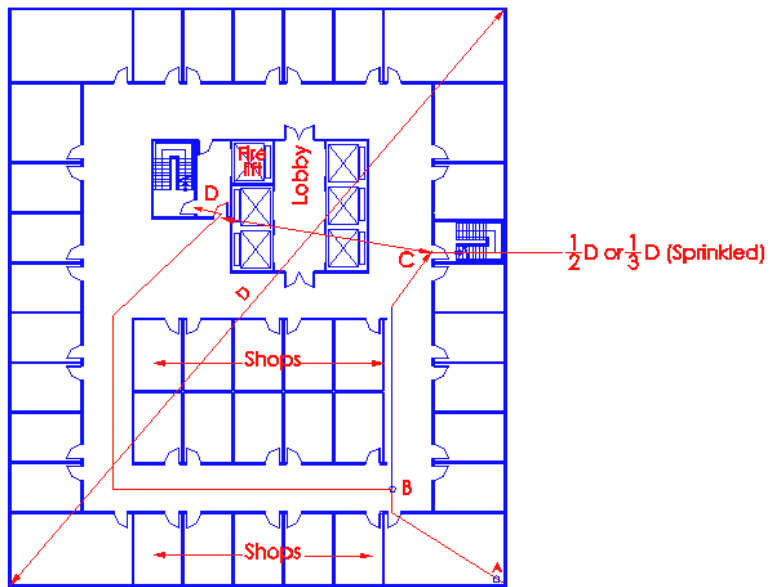

Diagram 2.2.6 (a) & (b) -3

A to B is considered as one-way travel distance and it shall be not more than 25m (sprinklered). In computing two-way travel distance, the escape route from point A, B, C shall not exceed 60m (sprinklered).

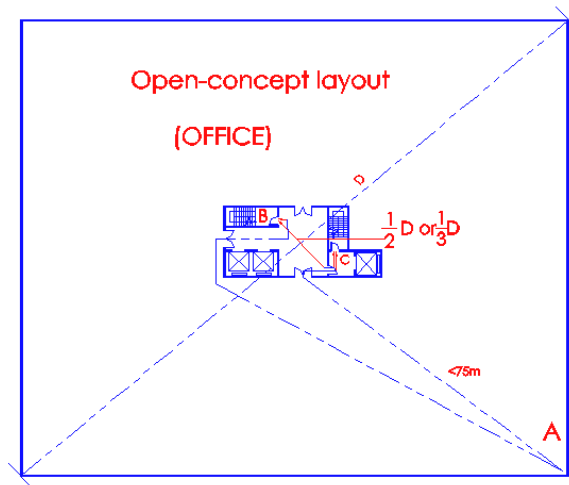

Diagram 2.2.6 (a) & (b) -4

Point A to C and Point A to B are considered two-way travel distance if the separation distance between exit doors of the two staircases is equal to or more than $\frac{1}{2}D$ or $\frac{1}{3}D$ (sprinklered). If the storey space is to be subdivided for occupation by more than one occupier, a common corridor around the service core shall be created to meet the travel distance requirements.

2.2.6

Some examples of one-way direct and travel distances from subdivision of storey spaces

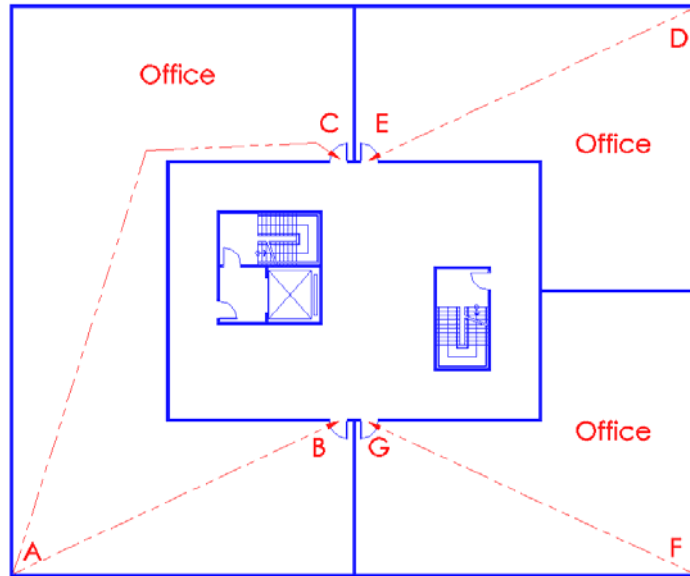

Diagram 2.2.6 (a) & (b) -5

Escape routes AB, AC are considered two-way direct travel. Escape routes DE, FG are considered one-way direct travel distances.

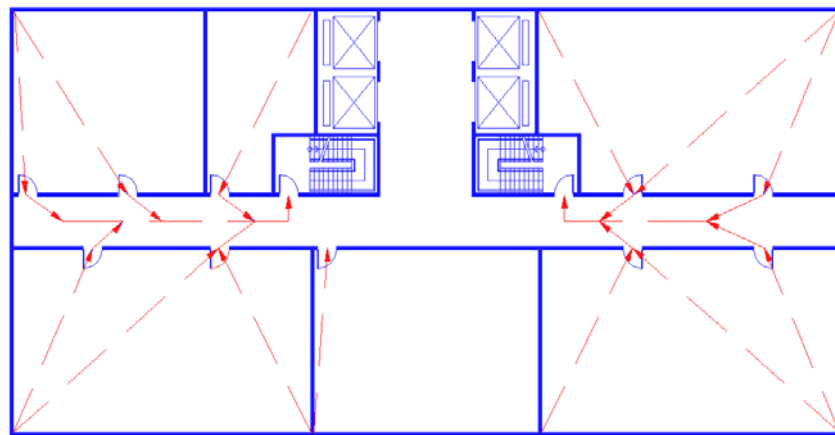

Diagram 2.2.6 (a) & (b) -6

The numerous one-way direct travel distances are illustrated by dashed lines.

The provision of fixed corridors and rooms in an open floor space would create numerous "common paths" from the rooms to the exit staircases as shown in the above diagram. Common paths of travel are one-direction travel only without the choice of travelling in another separate direction toward an exit.

2.2.6

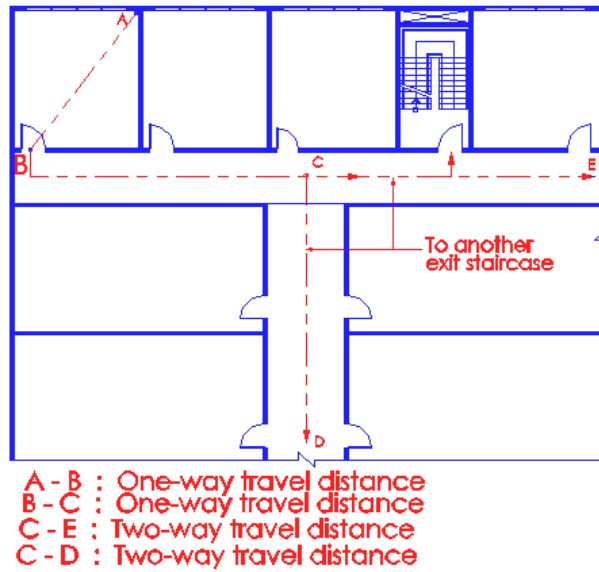

Diagram 2.2.6 (a) & (b) -7

In determining the types of travel distance, Point A, B or C is considered one-way travel distance or "common path". At point C, where an occupant has the choice of more than one escape direction, would be considered as the starting point for 2-way travel distance. Hence, escape routes C E and C D are considered two-way travel distance.

- (c) For the purpose of this clause, the most remote point from which the travel distance is measured shall be taken as being 400mm from the enclosure walls of the room or space, and

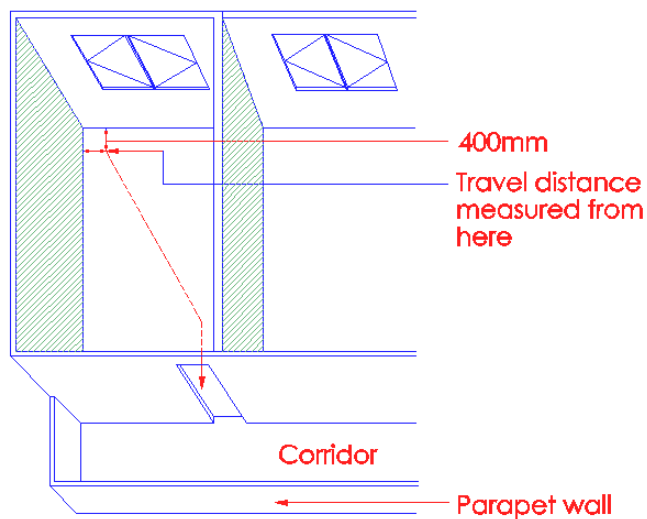

Diagram 2.2.6 (c)

- 2.2.6 (d) In the case of a hotel bedroom, travel distance shall be determined based on the provisions under Cl.2.7.4 for Exit Requirements for Hotels, and

(No illustration)Please refer to clause 2.7.4

- (f) Where Area of Refuge is provided in lieu of required exits, travel distance shall be measured to the exit door at the corridor leading to the Area of Refuge, and

Where an area is designated as 'area of refuge' (Building B in diagrams 2.2.6 (f) – 1 & 2), it must have adequate provision and shall be adequate in size to hold the occupant load it receives from the floor area (Building A) it serves, allowing at least 0.3m² per person. Area of refuge acts as a temporary holding area allowing the occupants more time for evacuation. Hence, it shall be protected from the fire and smoke risk from building A via the provision of cross-ventilated bridges or protected external passageways.

While some conditions for the area of refuge are given below, reference shall also be made to Cl.1.2.4 and Cl.2.2.15 for more explanations and details on the area of refuge.

Area of refuge

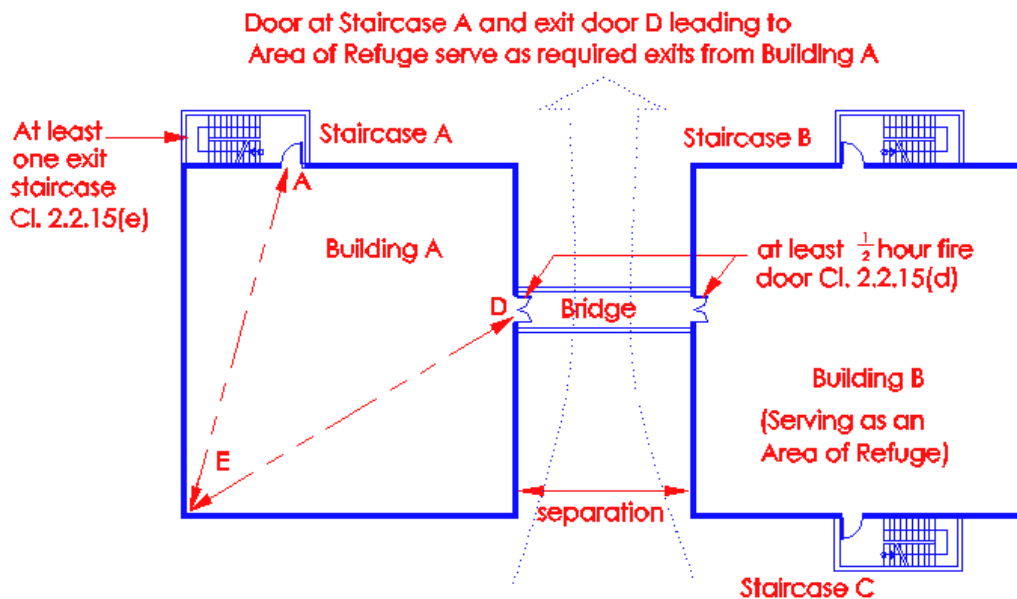

Diagram 2.2.6 (f) - 1

Lines EA and ED are taken as two-way Direct Distance Measurements.

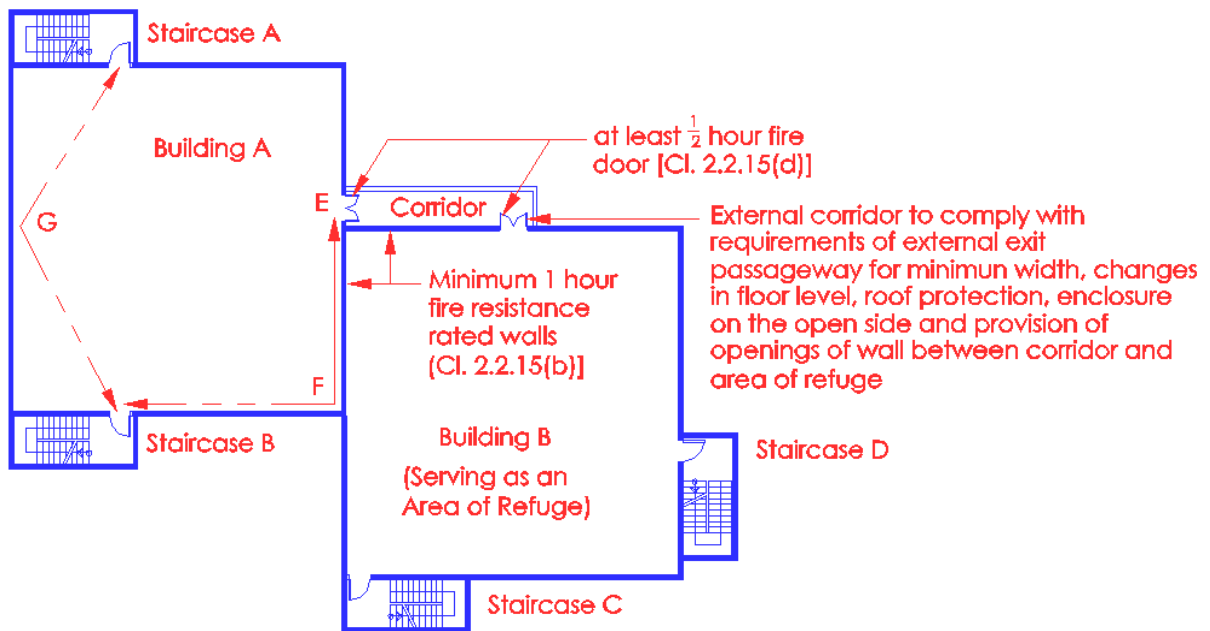

Diagram 2.2.6 (f) - 2

General conditions for Area of Refuge

- * *Area of Refuge shall be adequate in size to hold the occupant load it receives from Building A, in addition to its own occupant load calculated on the basis 0.3m² per person.*
- * *Each connecting area or floor served by an Area of Refuge shall have at least one protected staircase or exit facility of adequate width discharging at ground level.*
- * *Access door to area of refuge shall be kept accessible at all times*
- * *Door D & E, {in diagrams 2.2.6 (f) – 1 & 2 respectively} leading to area of refuge can also be treated as a required exit from the area served by it, and hence travel distance can also be measured to these doors.*

- 2.2.6 (g) Where permitted under Cl. 2.3.3 for exit staircases to be entered without the provision of an exit door, the travel distance shall be measured to a position where the exit door would be installed if otherwise required.

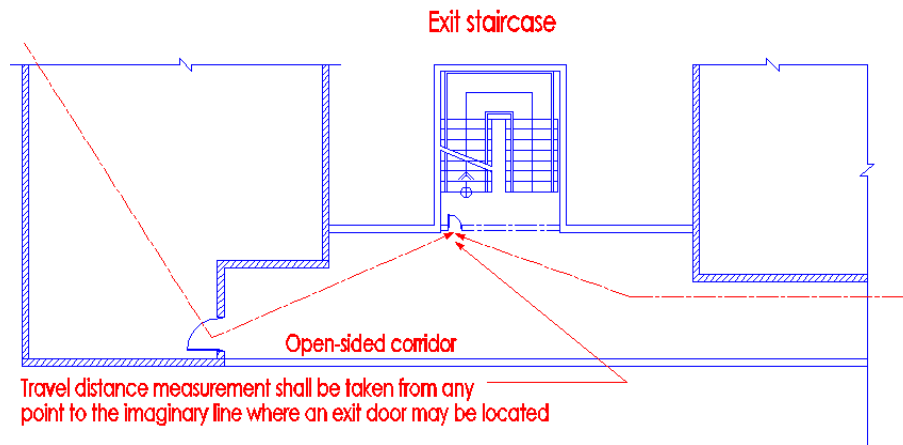

Diagram 2.2.6 (g)

Ancillary office within other purpose groups

- 2.2.6 (h) Where an ancillary office is housed within a space belong to other purpose groups, the travel distance requirement for the ancillary office is allowed to be based on purpose group IV, provided :
- (i) the ancillary office is fire compartmented from spaces belonging to the other purpose groups; and
 - (ii) the ancillary office occupants shall have access to exit(s) within the ancillary office compartment leading to direct discharge at ground level into a safe exterior open space, into a protected exit staircase or internal/external exit passageway.

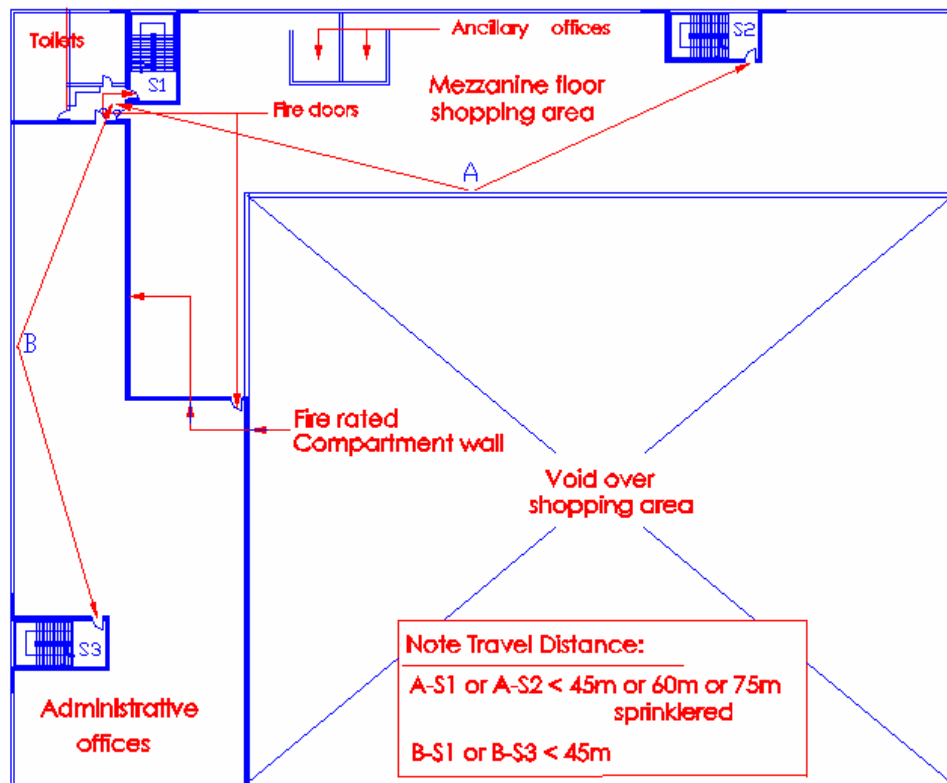

Diagram 2.2.6(h)

The fire risk in office space is lower than shopping space. If there is fire separation between office and shopping spaces as shown above, the travel distance requirement for the ancillary office is allowed to be based on office use under purpose group IV.

2.2.7 Minimum width

No exit, exit staircase or other exit facilities shall be narrower than the minimum width requirement as specified under Table 2.2A. The minimum clear width of an exit door opening shall not be less than 850mm.

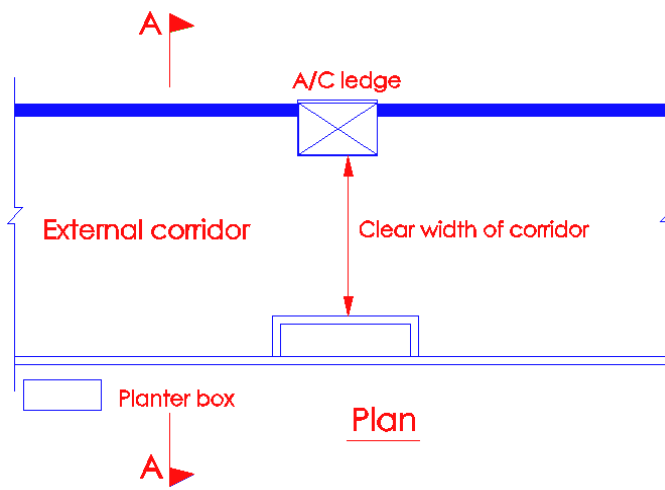

Diagram 2.2.7 – 1

Clear width of corridor leading to an exit shall not be less than 1000mm.

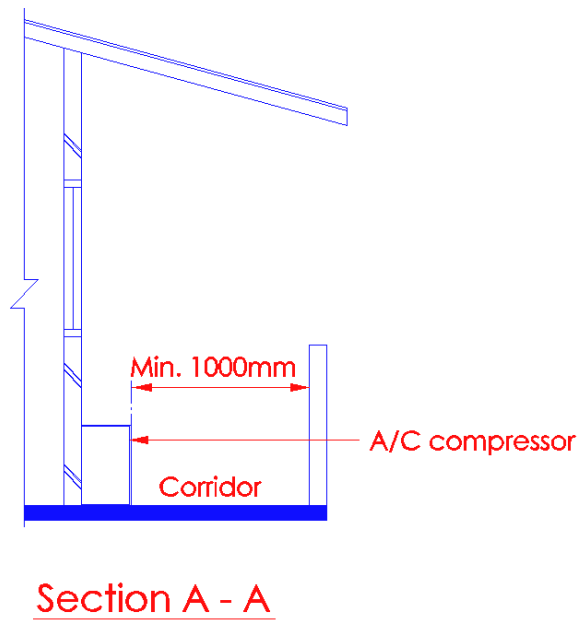

Diagram 2.2.7 – 2

Other exit facilities refer to exit passageways, defined corridors, etc.

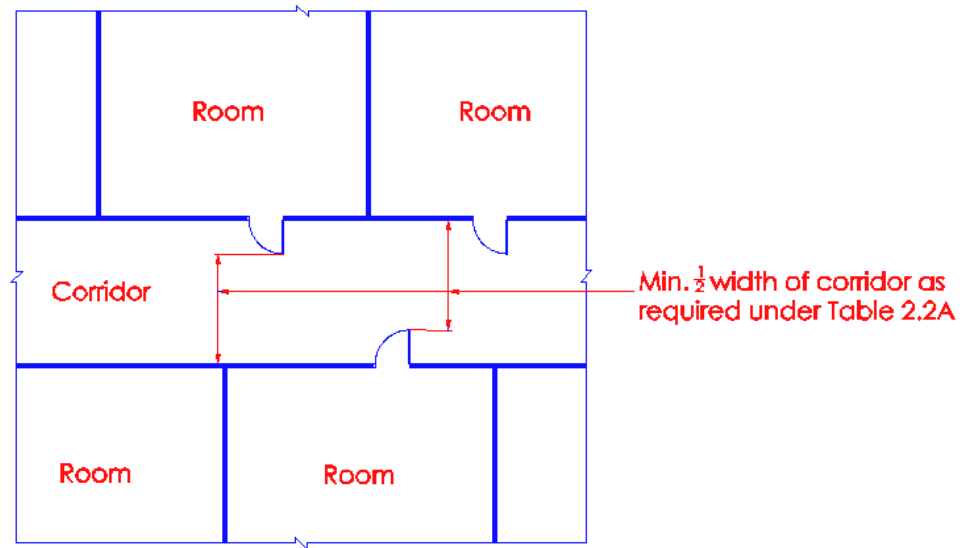

Diagram 2.2.7 - 3

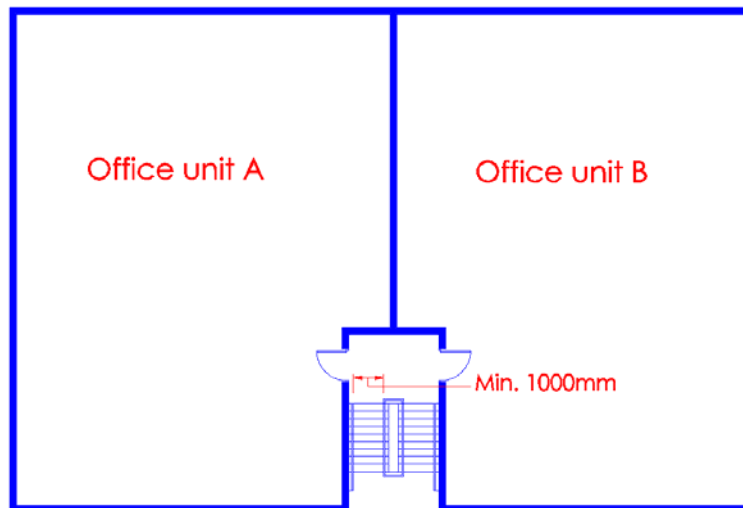

Diagram 2.2.7 - 4

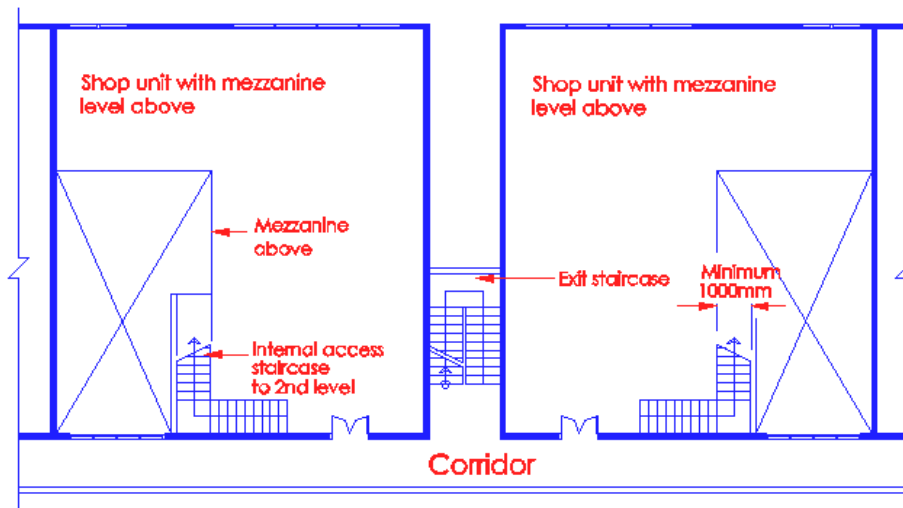

Diagram 2.2.7 - 5

Clear width of internal access staircase in shop unit with mezzanine level shall not be less than 1000mm. The One-way travel distance from the most remote point on mezzanine level to the exit door on the main storey level of shop shall not exceed the permissible limits of Table 2.2A.

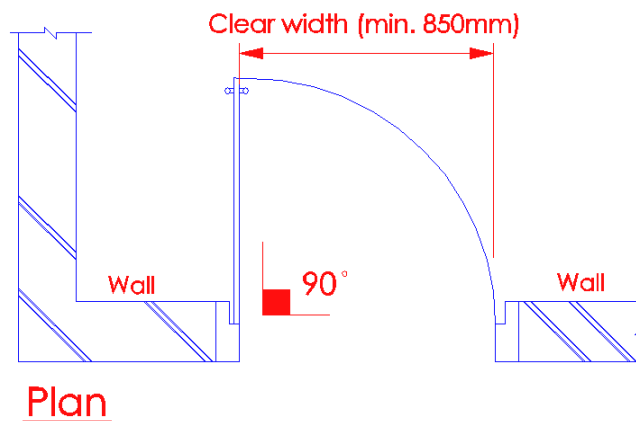

Diagram 2.2.7- 6

Clear width of exit door opening shall not be less than 850mm. This shall be measured clear of any protrusion except doorknob or lockset, subject to complying with exit requirements. 850mm is equivalent to 1¹/₂ units of width only, for the purpose of determining the exit capacity.

2.2.8 Maximum width

The maximum width of exit staircases shall be not more than 2000mm. Where staircases exceed 2000mm in width, handrails shall be used to divide the staircase into sections of not less than 1000mm of width or more than 2000mm of width.

For the purpose of determining the exit capacity of a staircase that is wider than 2000mm that forms part of the required means of escape from any storey of the building, that part of its width in excess of 2000mm shall not be taken into account.

Maximum and minimum widths of Exit Staircases

The above sub-clause does not preclude the design of staircases wider than 2000mm. It is intended to limit the maximum number of occupants to be allocated to a single exit staircase, and thereby, prevent the concentration of the occupants' escape at any one point of exit. The consequences, if higher capacity is to be permitted through an exit staircase without capping, would be disastrous, if that staircase is to be rendered unusable in an emergency situation.

Hence, where a staircase is designed with a width greater than 2000mm, its total exit capacity shall be based on the capacity of only 4 units of exit width when determining the adequacy of exit provisions from that storey of building served by that staircase.

This staircase is also required to be sub-divided equally into 2 or more sections with handrails such that the spacing between the handrails are not less than 1000mm and not more than 2000mm.

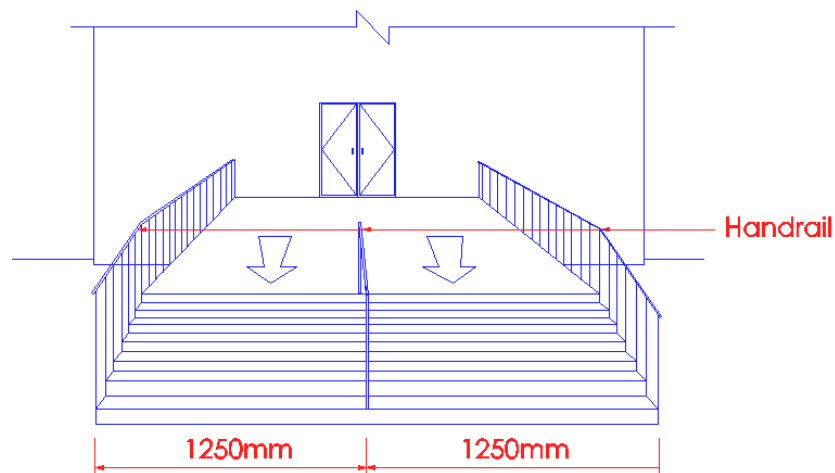

Diagram 2.2.8 - 1

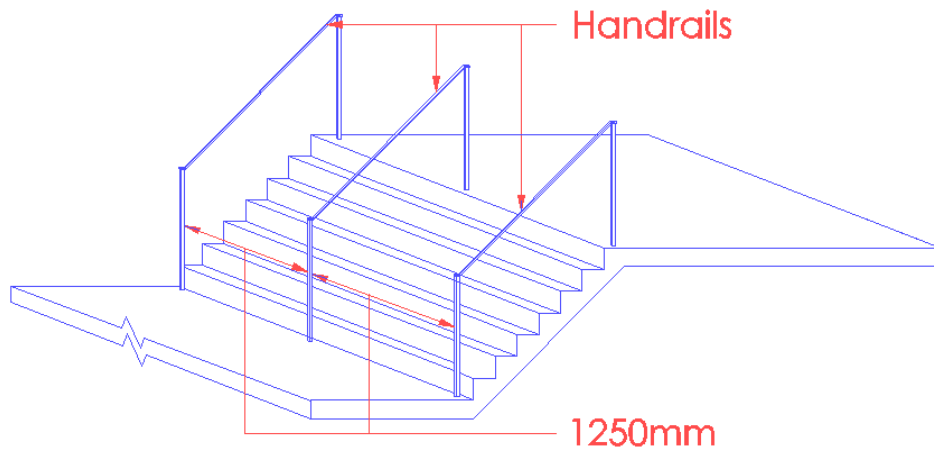

Diagram 2.2.8 - 2

The width of staircase of 2500mm is being divided into 2 sections of 1250mm each by the introduction of an intermediate handrail, although the staircase is 2500mm clear it is still computed as 2000mm only. Dividing staircase wider than 2000mm enables better crowd control and orderly evacuation in times of emergency.

2.2.9 Measurement of width

The measurement of width referred to under Clauses 2.2.7 and 2.2.8 shall be the clear width :

- (a) In the case of an exit staircase, between –
- (i) the finished surfaces of the walls, if the staircase is enclosed on both sides by walls only, or

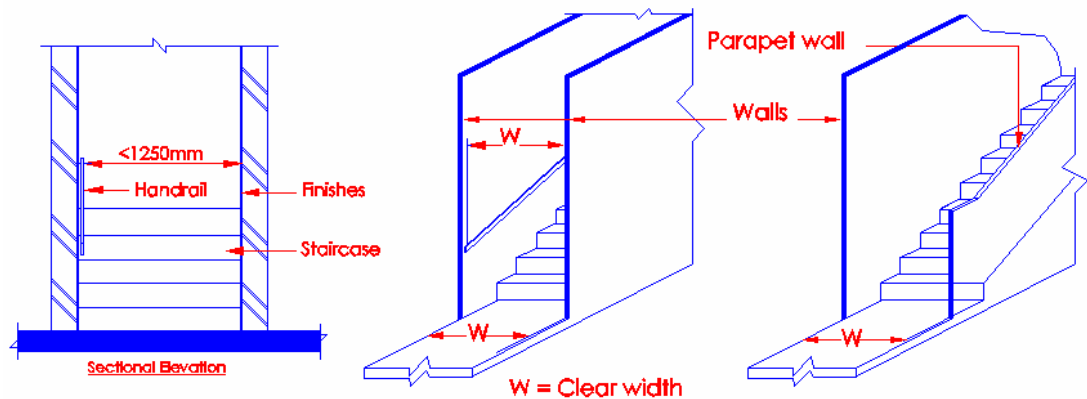

Diagram 2.2.9(a)(i)

- (ii) the finished surfaces of the wall and the inner side of the balustrade, if the staircase has a wall on one side and a balustrade on the other side, or

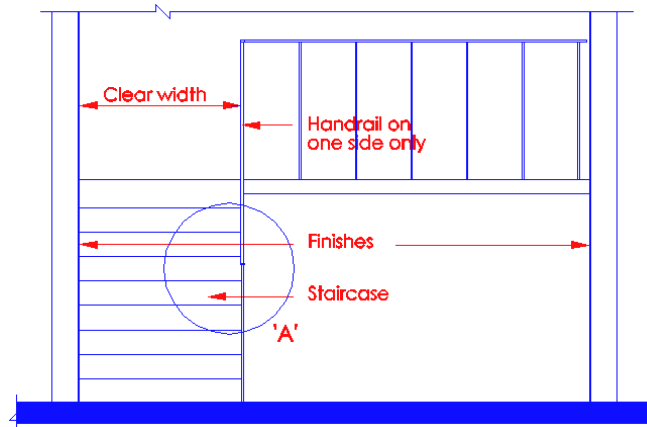

Diagram 2.2.9(a)(ii) - 1

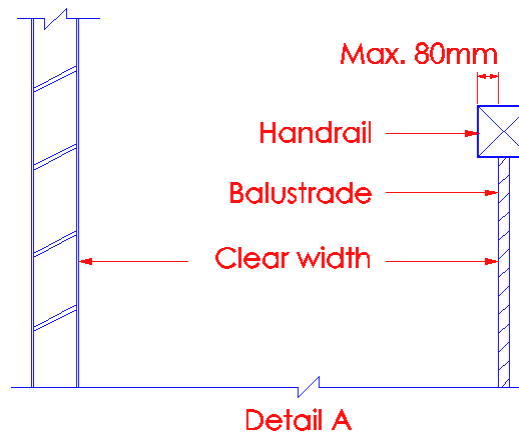
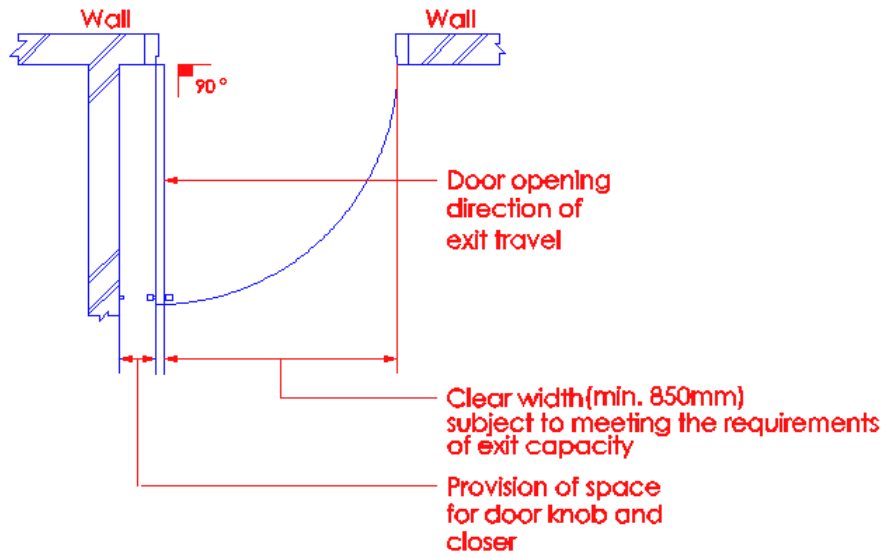

Diagram 2.2.9(a)(ii) - 2

- (iii) the inner sides of the balustrades if the staircase has balustrades on both sides, and

the projection of handrail into the clear width of a staircase shall not exceed 80mm on each side of the staircase. If the projection exceeds 80mm, the clear width of the staircase shall be measured from the inner sides of the handrails.

- (b) In the case of an exit door opening, between the edge of the door jamb or stop and the surface of the door when kept open at an angle of 90 degrees in the case of a single leaf door; and in the case of a double leaf door opening, between the surface of one leaf to the other when both leaves are kept open at an angle of 90 degrees. See diagrams 2.2.9(b) -1 and 2.



Plan : Single Leaf Door

Diagram 2.2.9(b) -1

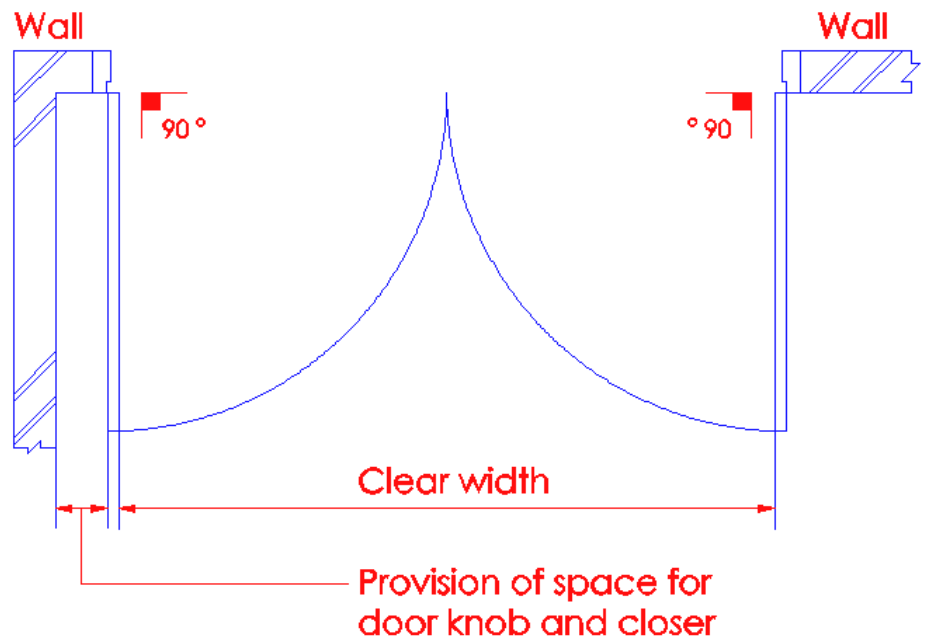

Diagram 2.2.9(b) -2

2.2.10 Number of exits from rooms and spaces

There shall be at least two door openings remote from each other and leading to exits from every room or enclosed space in which the total occupant load exceeds the maximum permissible occupant load for one door as listed in the table below:

Type of Occupancy	Maximum Occupant Load with One Door
High Hazard	10
Patient accommodation area	15
Classrooms	25
Dormitories	20
Godowns, stores, and factories not being of high hazard type	50
Assembly	50
Rooms and spaces with occupancy of more than 50 persons shall comply with the requirements for 'Number and Width of Exits' under Cl.2.8.2 for Assembly Occupancy.	

Note:	<ul style="list-style-type: none"> i. For residential occupancy, see cl.2.4. ii. For health care occupancy, see cl.2.5. iii. For office/shop, see cl.2.6. iv. For hotels, see cl.2.7. v. For assembly occupancy, see cl.2.8.
-------	---

(No illustration)

The table to clause 2.8.2 is reproduced for easy reference.

No of Occupants	Min No of Doors	Min. Width of Corridors
50 - 200	2	1000 mm
201 - 500	2	1250 mm
501 - 1000	3	1250 mm
exceeding 1000	4	1250 mm

In general, if an office is used as classroom (e.g. training room) having an occupant load of more than 50 persons, the provision of two exits will be required.

The occupancy load of 50 persons or more under clause 2.8.2 should not be taken as applicable to assembly occupancy only, it is applicable to all non-residential occupancies as a general requirement.

2.2.11 Number of exit staircases or exits per storey

There shall be at least two independent exit staircases or other exits from every storey of a building, unless otherwise permitted under other subsequent provisions of the code.

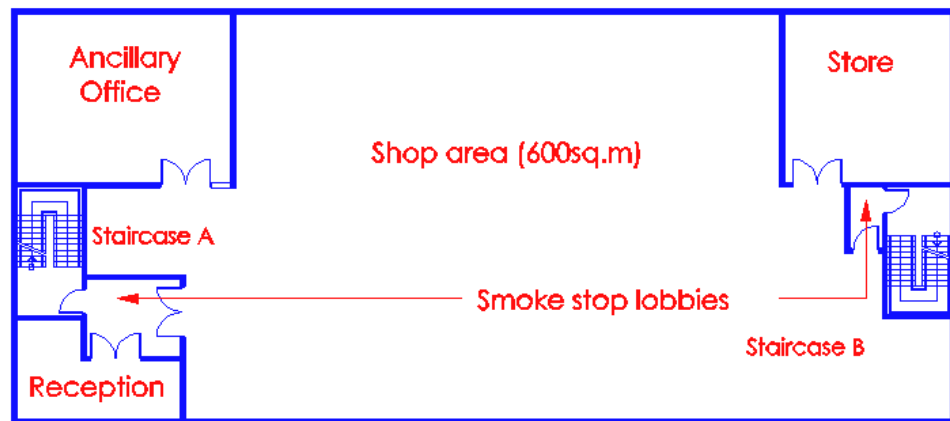

Diagram 2.2.11

Minimum requirement – 2 Exit Staircases per storey

Single exit is permissible if the storey of the building can satisfy the conditions stipulated in clauses 2.2.10 and 2.6 (for office/shop occupancy).

2.2.12 Location of exits & access to exits

All exits and access facilities shall be required to comply with the following:

- (a) Exits and access facilities shall be clearly visible or their locations shall be clearly indicated and shall be kept readily accessible and unobstructed at all times, and

(No illustration). Please refer to Chapter 8 for more details.

- (b) Every occupant or tenant within a building or a storey of a building shall have direct access to the required exit or exits without the need to pass through the spaces or rooms occupied by other occupants or tenants.

Where any storey of a building is occupied by more than one tenant, it is imperative that each occupant from any of the tenancies shall have direct accessibility to alternate exit staircases without having to enter other tenancies. This could be facilitated via common or neutral spaces like corridors or lobbies that are accessible to all occupants on that storey.

Examples of correct method of determining access routes to the required exits:

Multiple Tenancy - each with access to the two exit staircases

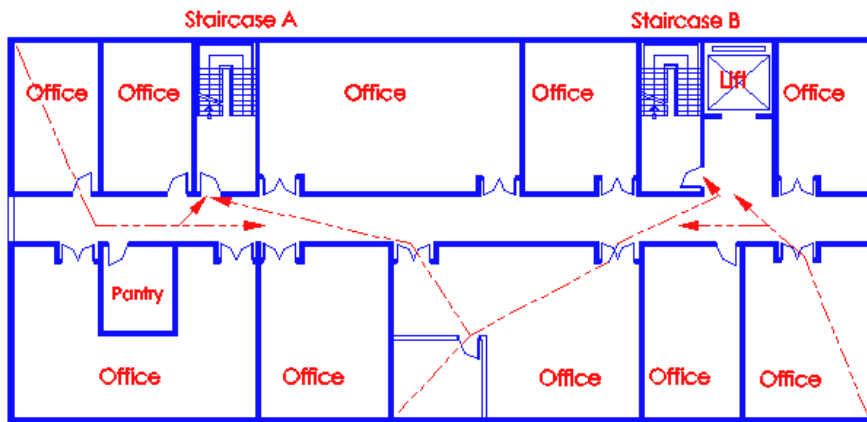

Diagram 2.2.12 (b) – 1

Acceptable

Two tenancies, both with access to two smoke-stop lobbies

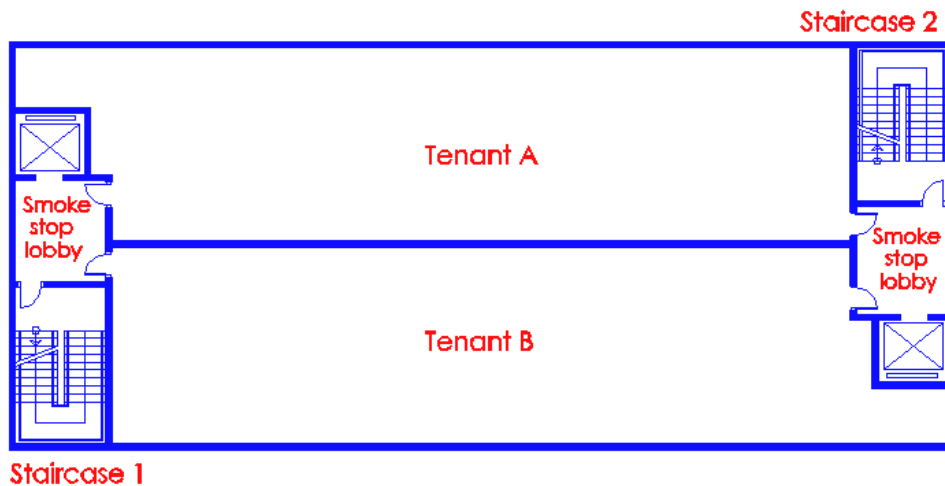

Diagram 2.2.12 (b) – 2

Not Acceptable

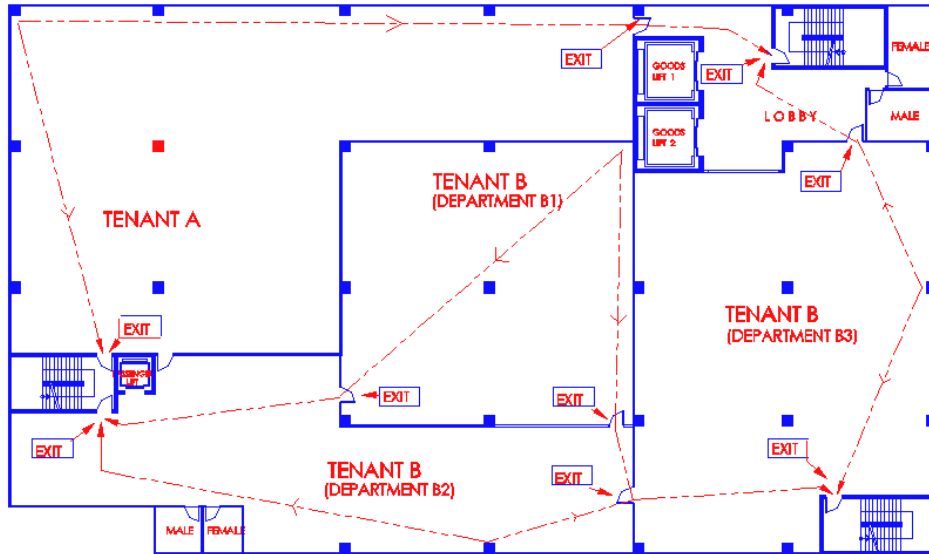

Diagram 2.2.12 (b) – 3

Diagram 2.2.12 (b) – 3 shows an incorrect method of determining access travel routes as the paths have to traverse through the room occupied by other occupants. Departments B1, B2, B3 are single tenancy. While Department B3 has direct access to both exit staircases, occupants in B1, B2 are required to traverse Department B3 to reach an exit staircase. As such, it is considered not acceptable even though travel distance meet the stipulated maximum distance requirements.

Another example of a layout that is NOT Acceptable

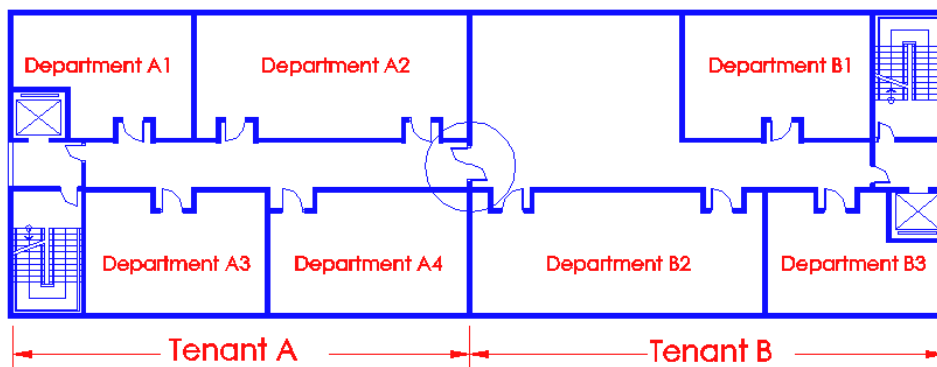

Diagram 2.2.12 (b) – 4

This arrangement of exits for the separate tenancies is not acceptable because the central door, circled in diagram 2.2.12 (b) – 4, would be kept locked for security reasons and to prevent or avoid any intrusion from one another. This would render the occupants from that storey with insufficient number of exits for escape in an emergency.

Despite, meeting the two-way travel distance requirements, tenants should have direct access to two exit staircases without having to traverse through door of other tenancies. Thus, such layout is not acceptable.

- (c) When more than one exit is required from any room or space or a storey of a building, each exit shall be placed as remote as possible from the other as permitted under Cl.1.2.60 (a), (b) or (c).

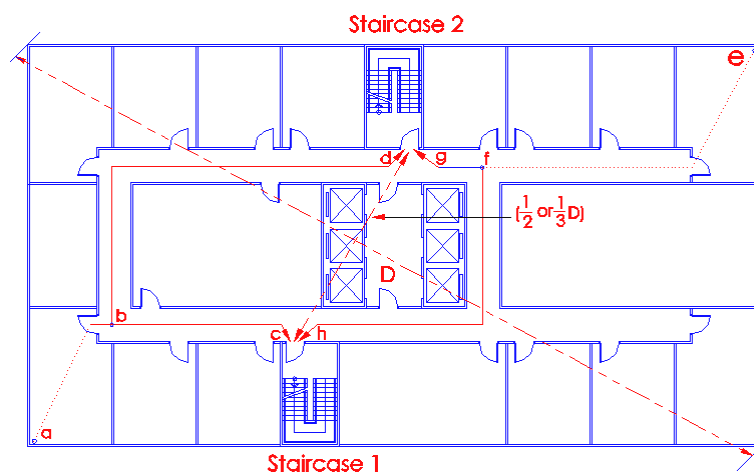

Diagram 2.2.12 (c) - 1

Distance between exit door of staircase 1 to that of staircase 2 shall be at least $\frac{1}{2}$ (or $\frac{1}{3}$, if sprinkler protected) the longest diagonal of the building indicated as (D) in the above diagram.

One-way travel distance exists where a space is arranged so that occupants within that space are able to travel in only one direction to reach any of the exits or to reach the point at which the occupants have the choice of two-way travel to remote exits.

For example, the portions of the escape routes in an office development from points a to b and e to f are one-way travel, which shall not exceed $\frac{2}{3}$ of 15m or 30m (sprinklered) as the office tenants' spaces are not yet subdivided by partitions. The option to travel in another escape route occurs at points b and f, which provide two-way travel distances to the exit staircases 1 & 2 respectively. The dashed lines indicate one-way travel distances. See further illustrations under cl.1.2.60 (a), (b) or (c).

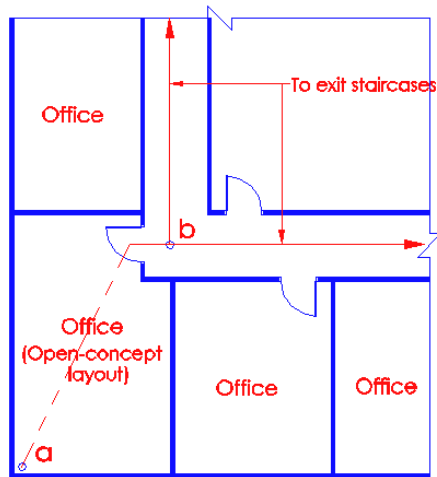

Diagram 2.2.12 (c) - 2

The office unit is small in floor area and considered as having an open-concept layout, thus point 'a' to point 'b' should not exceed the maximum one-way travel of 15m.

Single Occupancy

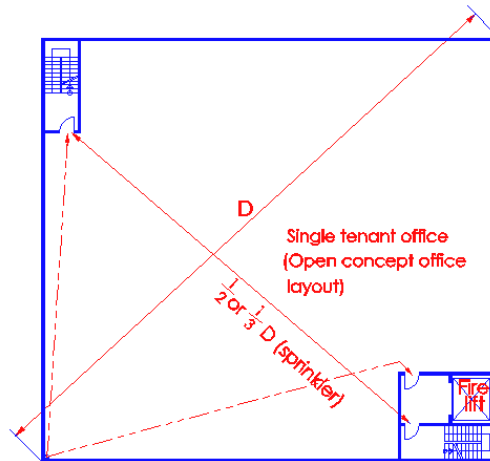

Diagram 2.2.12 (c) - 3

The above diagram shows a single tenant office floor with open concept layout. To determine travel distance, it shall be taken as $\frac{2}{3}$ of the maximum travel distance.

This is to cater for future partitioning works or alteration of the workstations layout that would increase the travel distance from any point in the floor space to the exit staircases.

2.2.13 Smoke free approach to exit staircase

Entry at every storey level to an exit staircase of any building or part of a building more than four storeys above ground level shall be through:

(a) External approach

An external exit passage way or external corridor. The openings for natural lighting and ventilation to the corridor shall be so located that they face and open upon:

- (i) The external space; or
- (ii) A street, service road or other public space which is open to the sky; or
- (iii) an air-well which opens vertically to the sky and having a min. width of 6m and a superficial plan area of not less than 93m².

It is important that exit staircases are kept free of any smoke at all times, especially in times of a fire emergency, as it is the main essential means for evacuating occupants from the building. In order to attain this smoke free environment, a buffer zone is created at the entry of the staircases. In the diagram below, the buffer zone takes the form of an external corridor and lift lobby. These unenclosed spaces, which are relatively free of smoke for safe escape of the occupants, are referred to as smoke free approach.

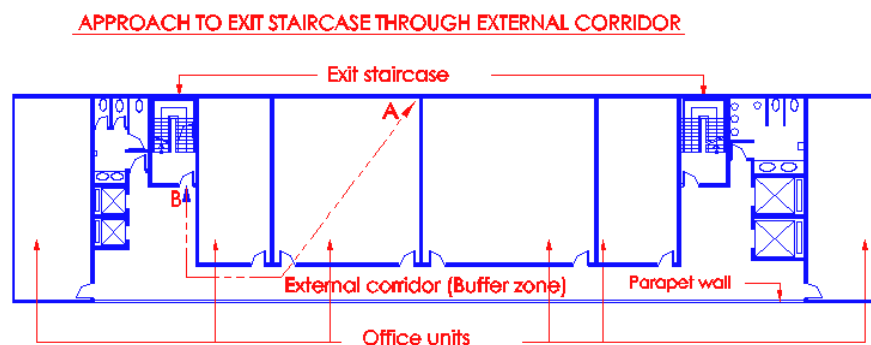

Distance AB is taken as the Direct Travel Distance from point A
Distance BC is taken as Travel Distance

Diagram 2.2.13(a) – 1

Travel Distance measurement, as shown by line AB in diagram 2.2.13 (a) – 1, in the external corridor situation is taken from the most remote point within the occupied area to the exit door of the exit staircase.

External Exit passageway, as shown in diagrams 2.2.13 (a) – 2 to 4 below, is a protected area, which is an extension of the vertical exit staircase. It is a provision to overcome excessive travel distances.

A Smoke screen should be provided above the passageway before the entry into the exit staircase to prevent smoke at the ceiling level from entering the staircase.

Approach to exit staircase through external exit passageway

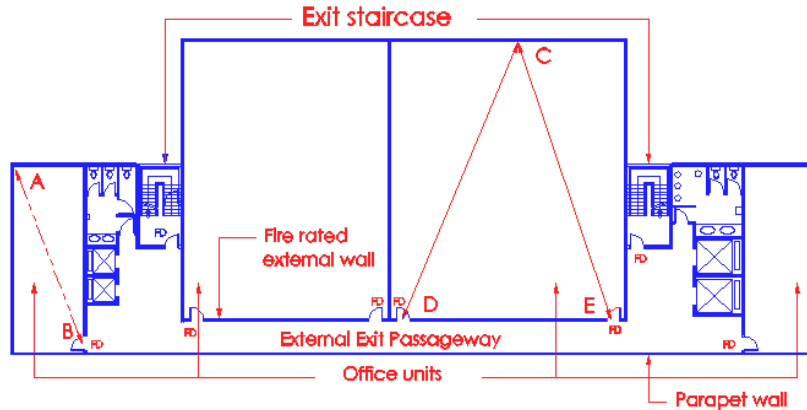

Distance AB = One-way direct distance from point A
 Distance CD or CE = Two-way direct distance from point C
 All doors opening to external exit passageway shall be fire rated
 FD - Fire rated exit door

Diagram 2.2.13(a) – 2

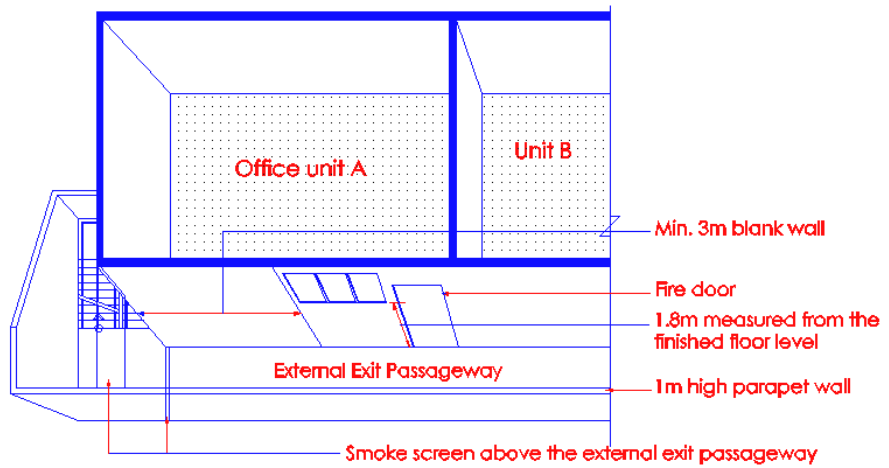

Diagram 2.2.13(a) – 3

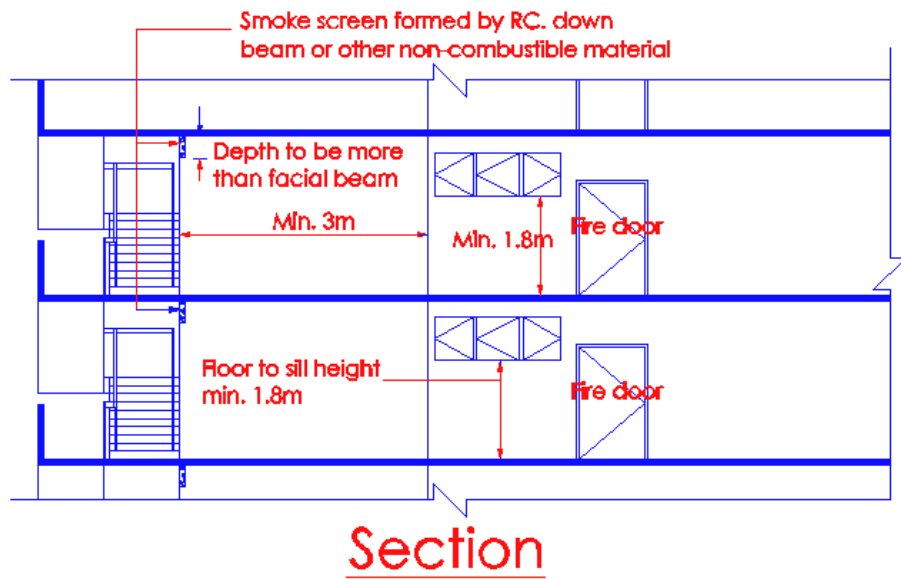

Diagram 2.2.13(a) – 4

In order for the smoke screen to be effective in preventing smoke from streaming into the staircase enclosure, it shall be brought lower than the facial beam of the external exit passageway.

Main differences between external corridor and external exit passageway

	<i>External Corridor</i>	<i>External Exit Passageway</i>
<i>Entrance door</i>	<i>No fire rating</i>	<i>Fire rated as per compartment</i>
<i>Usage</i>	<i>As smoke free approach</i>	<i>As extension of the exit staircase</i>
<i>Ventilation openings for occupied areas into:</i>	<i>No restriction</i>	<i>1800mm or higher from finish floor level of passageway</i>

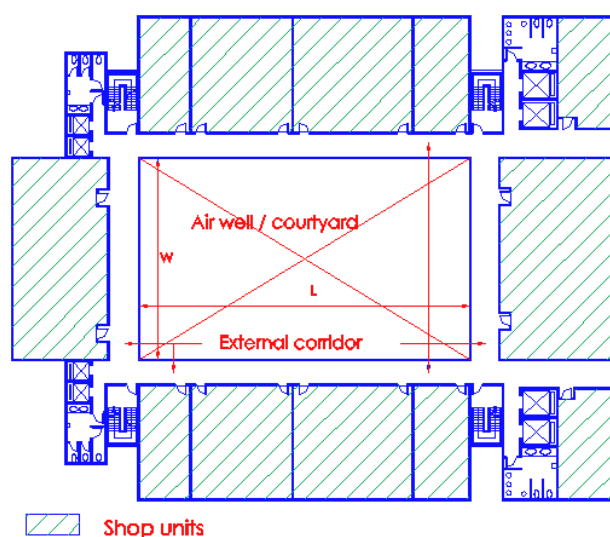

Diagram 2.2.13(a)(iii) - 1

The height of parapet walls of corridors alongside an air-well shall not exceed 1000mm measured from its finished floor level. It shall be noted here that the ventilation openings for exit staircases in the above design layout shall not open into the air-well.

2.2.13 (b) Smoke-stop lobby

a lobby that is separated from the adjoining areas of the building by a wall having a fire resistance of at least 1 hour. The exit access door shall have fire resistance of at least half an hour fitted with automatic self-closing device conforming to the requirements of Cl.3.9.2. The design of a smoke-stop lobby must be such as not to impede movement of occupants through the escape route. The floor area of a smoke-stop lobby shall be not less than 3m² and if a smoke-stop lobby also serves as a fire fighting lobby, the floor area shall be not smaller than 6 m² and with no dimension smaller than 2m. The floor shall be graded from the lift door towards the lobby door with a fall not exceeding 1 in 200.

A smoke stop lobby, including fire-fighting lobby, which acts as buffer space for entry into the protected staircase and use by fire fighters during emergency, shall be maintained as common property.

For illustrations see clauses 1.2.34 and 1.2.58 in Vol. 1 of the Handbook on Definitions for fire fighting and smoke stop lobbies respectively.

A smoke-stop lobby shall be ventilated by:

- (i) permanent fixed ventilation openings in the external wall of the lobby; such ventilation openings shall have an area of not less than 15 per cent of the floor area of the lobby and located not more than 9m from any part of the lobby, or

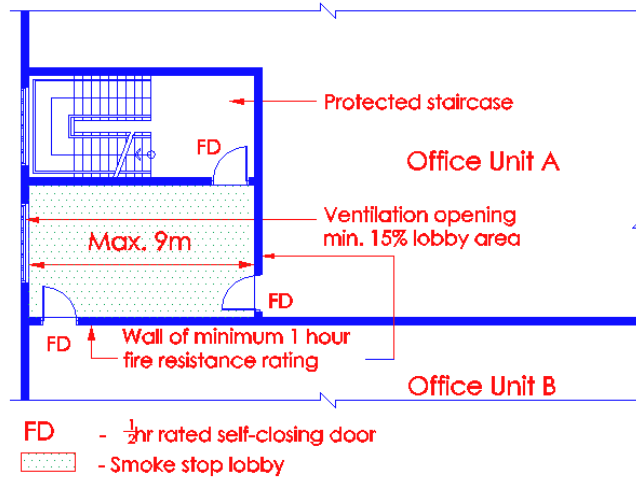
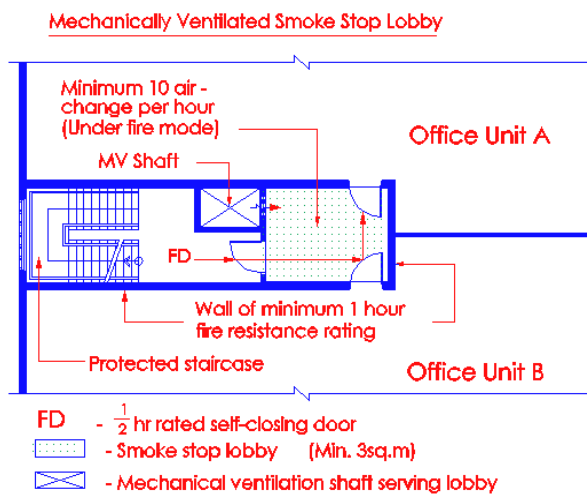

Diagram 2.2.13(b)(i)

For effective natural ventilation of the smoke stop lobby, all parts of the smoke stop lobby shall be within 9m of its ventilation opening. To ensure the integrity of smoke stop lobbies as dedicated buffers protecting exit staircases from smoke infiltration, it must be located in neutral spaces. This arrangement would prevent any misuse by tenants, as the case may be if the lobby is to be located within a privately owned space.

- (ii) mechanical ventilation complying with the requirements in Chapter 7, or



- (iii) permanently fixed ventilation openings of area not less than 15 per cent of the floor area of the lobby and located not more than 9m from any part of the lobby, opening to an open air well which is open vertically to the sky for its full height. The air-well shall have a horizontal plan area of not less than 10m² or 0.1m² for each 300mm of height of the building, whichever is the greater. The minimum width of such space shall not be less than 3000mm. The enclosure walls to the air well shall have a minimum fire resistance of 1 hour and have no openings other than ventilation openings for the smoke-stop lobby, exit staircase and toilets, or

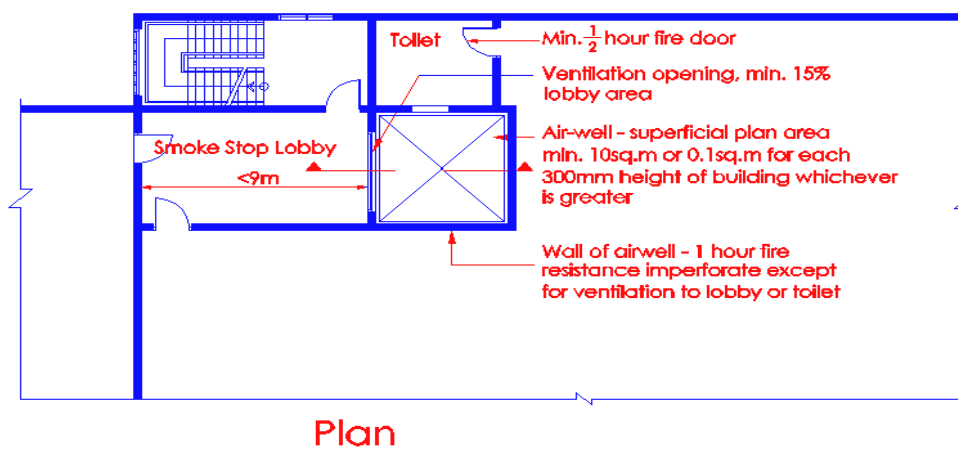

Diagram 2.2.13(b)(iii) - 1

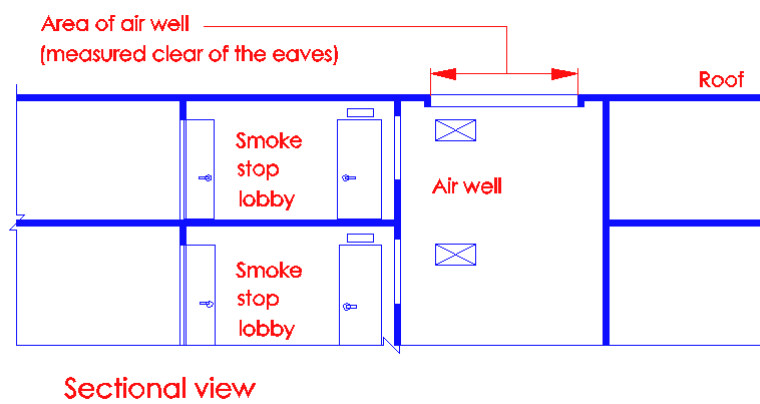

Diagram 2.2.13(b)(iii) - 2

The provision of air well to ventilate the internal smoke stop lobby as shown above is an alternative to mechanical ventilation. This provision is a relaxation to allow toilets, considered as wet areas having low fire risk, to ventilate into such air wells. The doors to the toilets shall have min. ½ hour fire resistance rating. The required area shall be maintained throughout its entire height and shall be maintained and fully open to the sky at all times.

- (iv) Cross-ventilated corridor having fixed ventilation openings in at least two external walls. The openings to each part of the external walls shall not be less than 50 per cent of the superficial area of the wall enclosing the corridors. No part of the floor area of the corridor shall be at a distance of more than 13m from any ventilation openings.

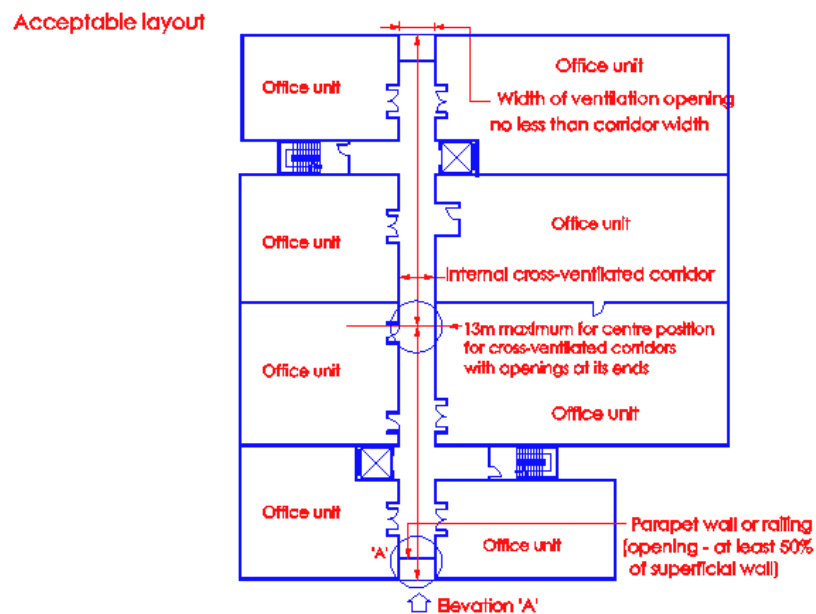

Diagram 2.2.13(b)(iv) – 1

For the purpose of measuring the horizontal distance of max. 13m from any floor space of the corridor to the ventilation openings, the ventilation openings shall be assumed to be located at the edge of the building and not at the edge of the corridor.

The above requirements shall not be taken to equal other clauses that require smoke free approach and cross-ventilated lobby approach under Cl.2.4.5 (f).

Not acceptable layout

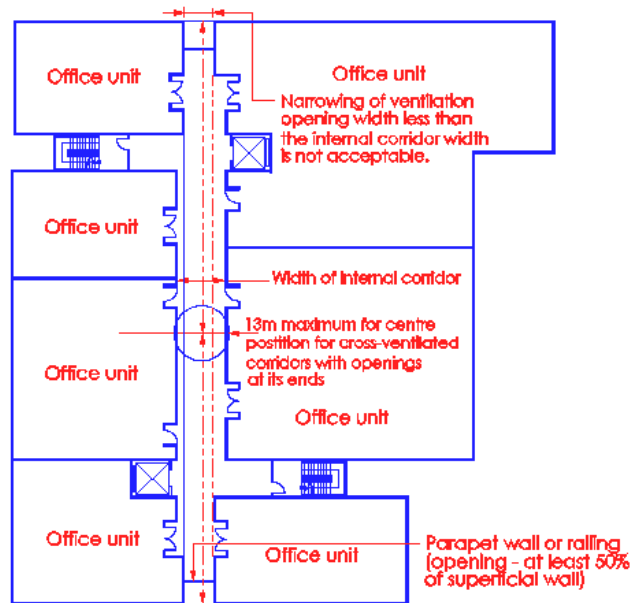

Diagram 2.2.13(b)(iv) – 2

The above provision of cross-ventilated corridor is not acceptable, as the ventilation opening on one side of the building is narrower than the width of the corridor. This could adversely affect the movement of air currents through the corridor, intended to draw out any smoke in the corridor area before it can affect the staircase.

2.2.13 (c) Exception:

Omission of smoke stop lobby is allowed

- (i) The omission of smoke stop lobby required under cl.2.2.13(b) to exit staircase of any building exceeding 4 storeys is allowed under the following situations, provided the door opening into the exit staircases shall be fire door of at least 1-hour fire resistance and fitted with automatic self-closing device to comply with the requirements of cl.3.9.2:
 - (a) where the internal exit staircase is provided with pressurization up to a habitable height of 24m in compliance with the requirements of Chapter 7;
 - (b) where an external exit staircase is constructed to comply with cl.1.2.29;

- (c) where an external exit staircase of a building is located along its perimeter wall and provided with uninterrupted external ventilation openings having not less than 50% of the planal area of the staircase at each storey level;

(Note: cl.2.2.13(c)(i) is not applicable to buildings under purpose group VII)

- (ii) The omission of smoke stop lobby to exit staircases shall not be allowed under the following situations : -

- (a) where the building exceeds 4 storeys and belongs to purpose group VII;
- (b) where the internal exit staircase, which is provided with pressurization, exceeds the habitable height of 24m;
- (c) where the exit staircase is designated as fire fighting staircase adjacent to a fire lift as required in Chapter 6.

(Note: cl 2.2.13(c) (ii)(b) is not applicable to buildings under purpose group VII)

Smoke stop lobby is exempted for the arrangements shown in diagrams 2.2.13 (c)(i) – 1 & 2 in building of Purpose Groups IV and V (office and shop) up to 60m high. The reasons for this relaxation being:

Any internal exit staircase without provision for natural ventilation and in habitable height not exceeding 60m will be provided with dedicated pressurization system. The door opening into the staircase is required to have minimum 1-hour fire resistance rating.

Partially enclosed staircase is required to be cross-ventilated having uninterrupted external openings of minimum 50% of the plan area of the staircase.

Fixed unobstructed ventilation openings

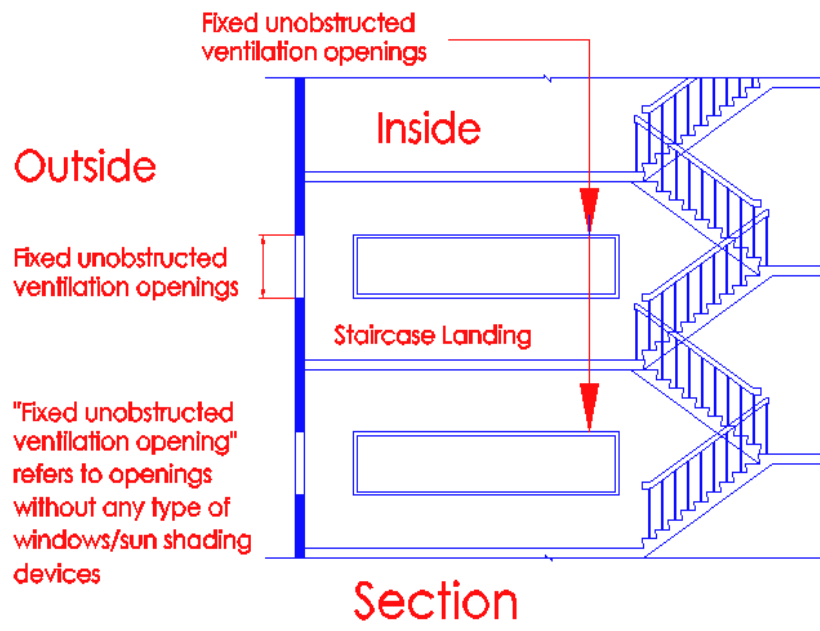

Diagram 2.2.13(c)(I) - 1

Conditions for Exemption

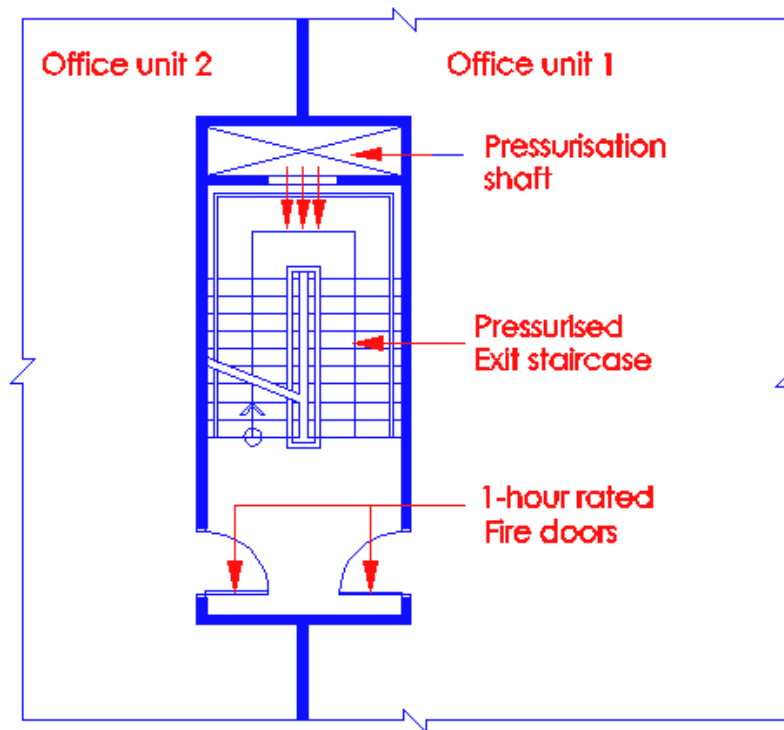

Diagram 2.2.13(c)(i) - 2

The positive pressure in the pressurised staircase diagram 2.2.13 (c)(i) - 2 acts to force smoke away from the doorway of the staircase when that exit door is opened, thereby preventing smoke entry into the staircase. The above exemption shall apply to building of which the habitable height does not exceed 24m. This is to meet the requirements under cl.2.3.3(g) and cl.7.2.1(a) which specifically require all internal staircases of building having a habitable height exceeding 24m to be pressurised. If the habitable height of the building exceeds 24m, the entry to the internal exit staircase shall be through smoke stop lobby or external approach.

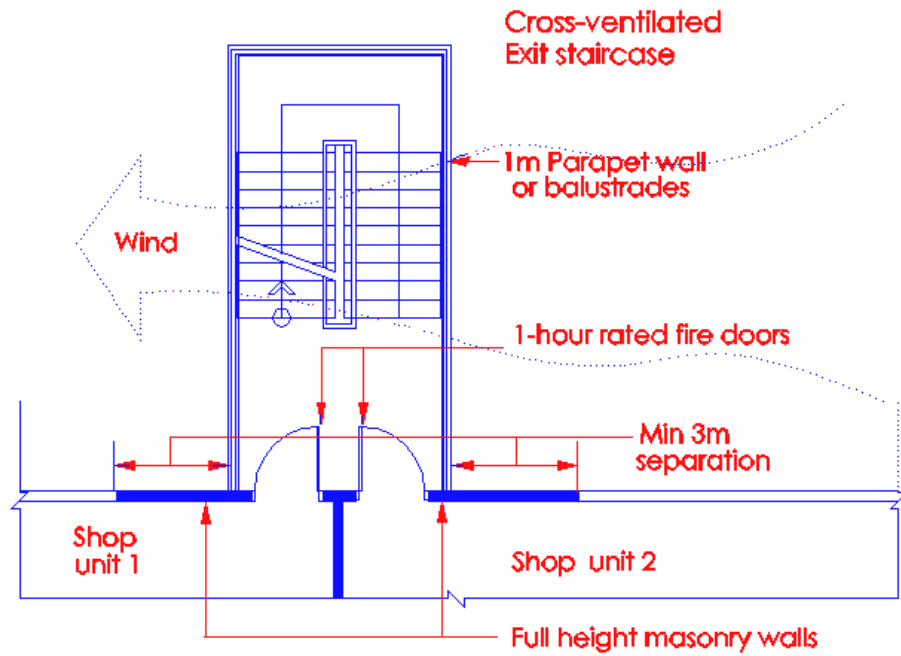

Diagram 2.2.13(c)(i) - 3

In the case of the cross-ventilated staircase (diagram 2.2.13 (c)(i) – 3, its open sides allow for quick dispersal of any smoke infiltrating the doorway when opened.

If the staircase is to be partially enclosed, uninterrupted external openings having 50% of the plan area of the staircase shall be provided for cross-ventilation.

Hence, in both these situations, it is possible to achieve a relatively safe smoke free environment in the exit staircase for facilitating escape for its occupants.

Situation where exemption does not apply when adjacent to fire lift

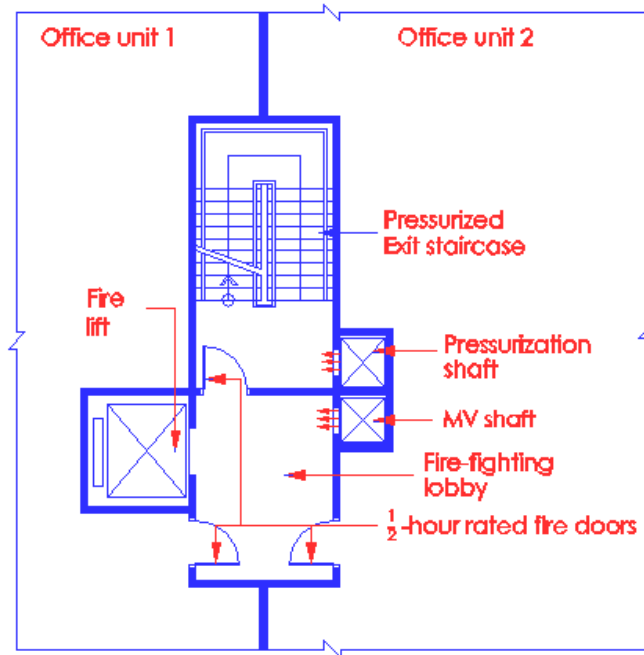

Diagram 2.2.13 (c) (ii) - 1

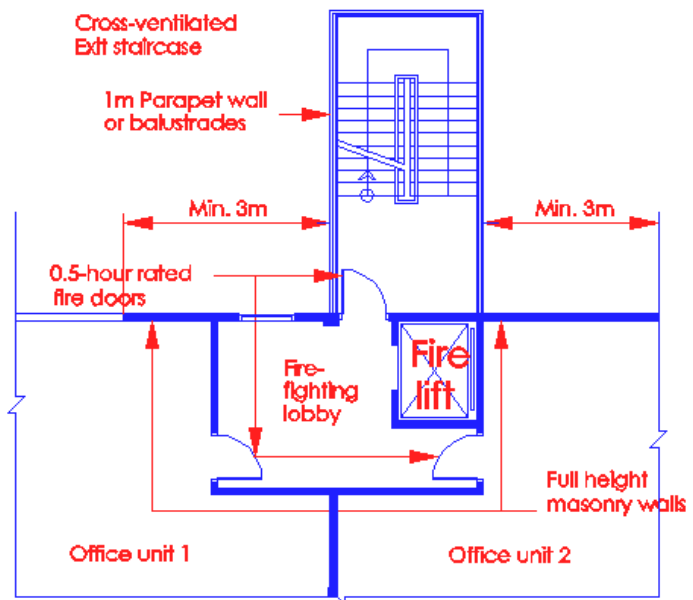

Diagram 2.2.13 (c) (ii) - 2

No exemption of the smoke stop lobby will be granted for such exit staircases if it is a fire-fighting staircase adjacent to a fire lift. The fire fighters would require the lobby space as a 'staging' point in their fire fighting operations, prior to entering into the affected areas, in fire emergencies.

Situation where exemption does not apply:

internal staircase serving building exceeding 24m habitable height

(refer to clauses 2.3.3(g) and 7.2.1(a) for pressurisation to exit staircase)

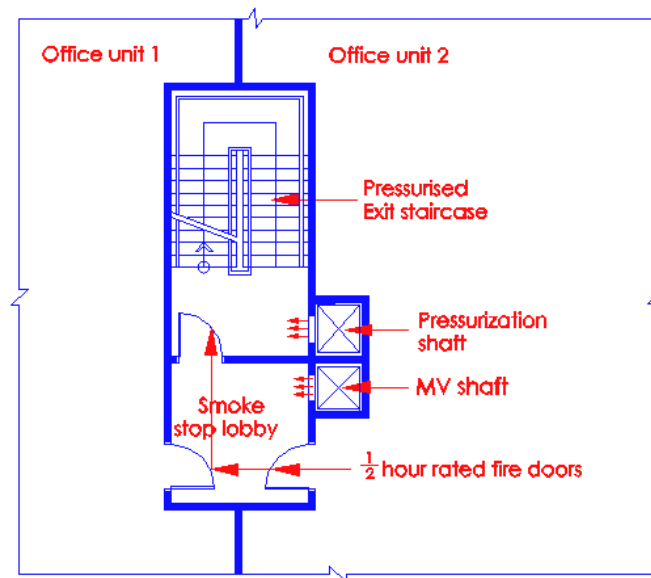

building with habitable height exceeding 60m

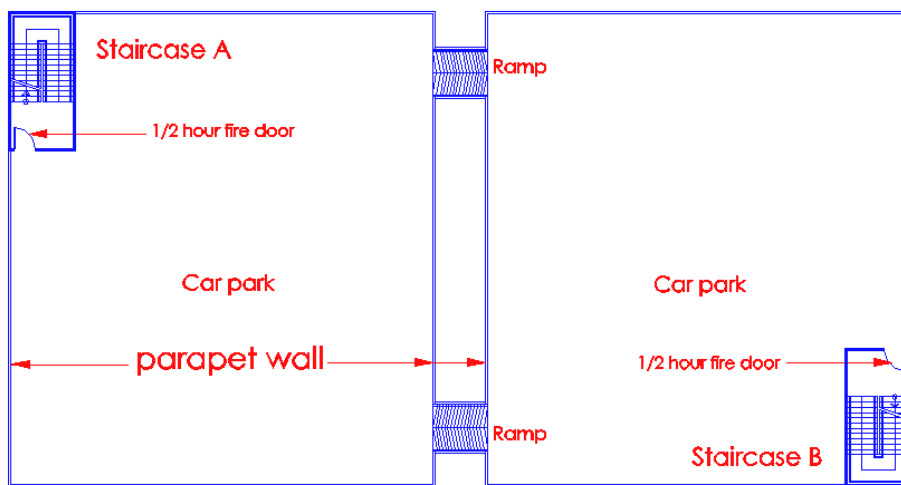

Plan

Open-sided multi-storey car park

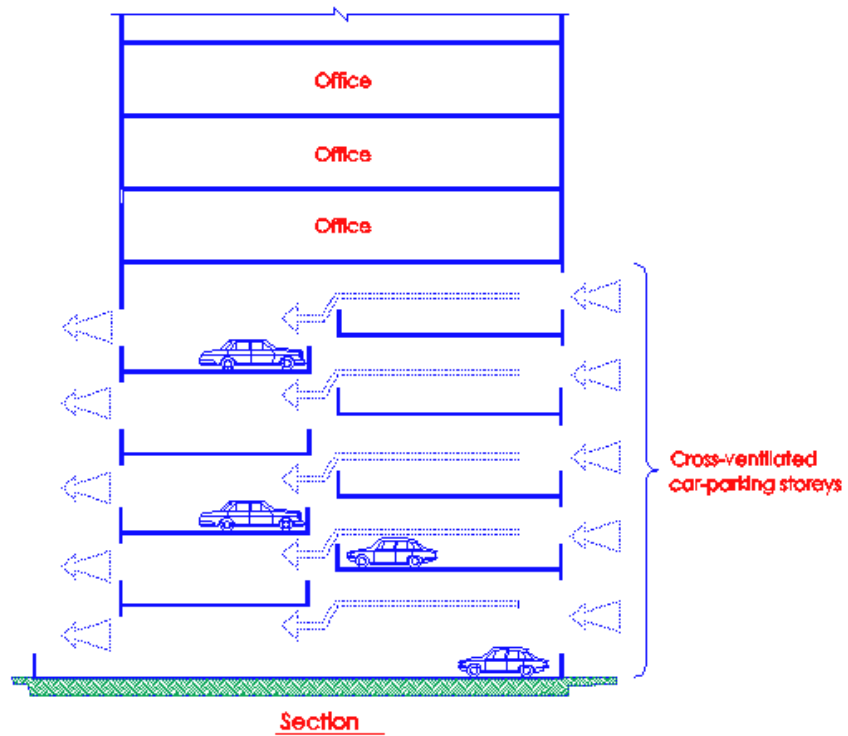

Diagram 2.2.13 (d)(i) - 2

In diagram 2.2.13(c)(ii) - 1, the space before the exit staircases can satisfactorily achieve a smoke free environment. The doors to the exit staircases shall be minimum 1-hour fire rated.

Likewise a cross-ventilated car parking storey in diagram 2.2.13(c)(ii) - 2 is exempted from the provision of smoke stop lobby to exit staircase. However, the upper storeys above the car parking floors are not exempted from provision of Cl.2.2.13(c)(ii).

Annex car park block

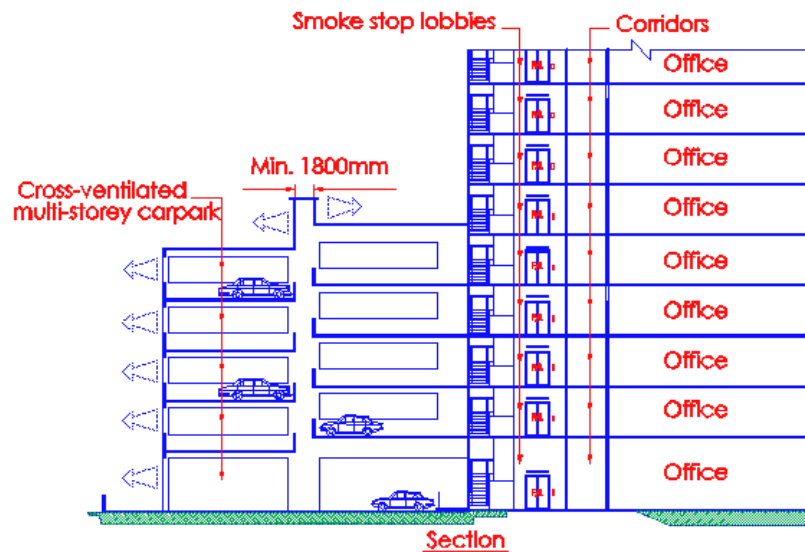

Diagram 2.2.13(d)(i) – 3

The above requirement exempts the provision of smoke stop lobby to exit staircases in cross-ventilated annex car park block only.

2.2.14 Smoke free approach to exit staircase in basement occupancy:

- (a) In a building comprising more than 4 basement storeys, entry to exit staircases serving the basement storeys at every basement storey level shall be through smoke-stop lobbies, one of which shall be designated as fire fighting lobby. The exit staircase connecting to the fire fighting lobby shall be pressurised to comply with the requirements in Chapter 7, and

More than 4 basement storeys

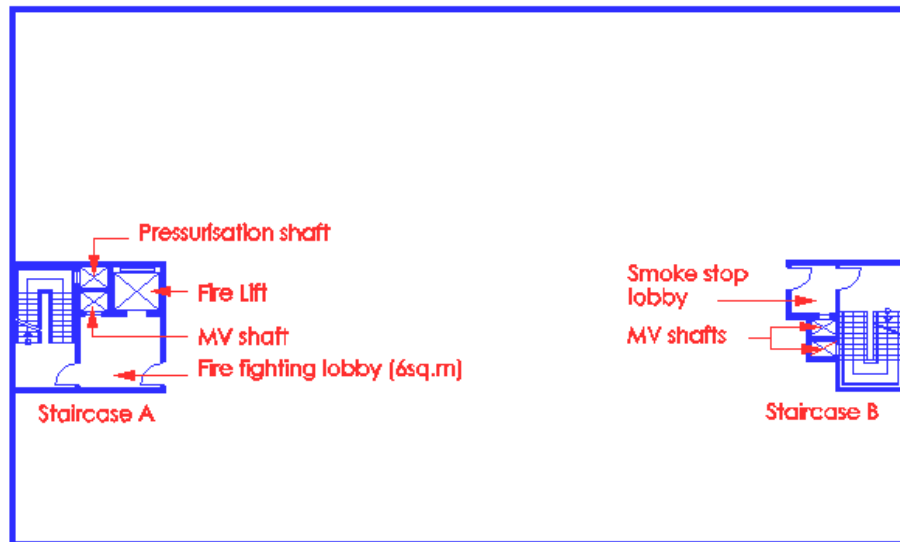

Typical Plan of Basement storey

Diagram 2.2.14 (a)

Smoke stop lobby is required for all staircases, one of which shall be designated as a fire fighting lobby. Also refer to clause 6.6.3. Owing to the depth of the basement, and to prevent heat and smoke from getting into the staircase, the provision of smoke stop lobby is required. This is similar to the requirement of smoke stop lobby to building exceeding 4 storeys above ground.

- (b) In a building comprising 2, 3 or 4 basement storeys, entry at every basement storey level to at least one of the exit staircases serving the basement storeys shall be through a smoke-stop lobby and where only one smoke-stop lobby is provided, it shall be required to serve as a fire fighting lobby, and

4 or less number of basement storeys

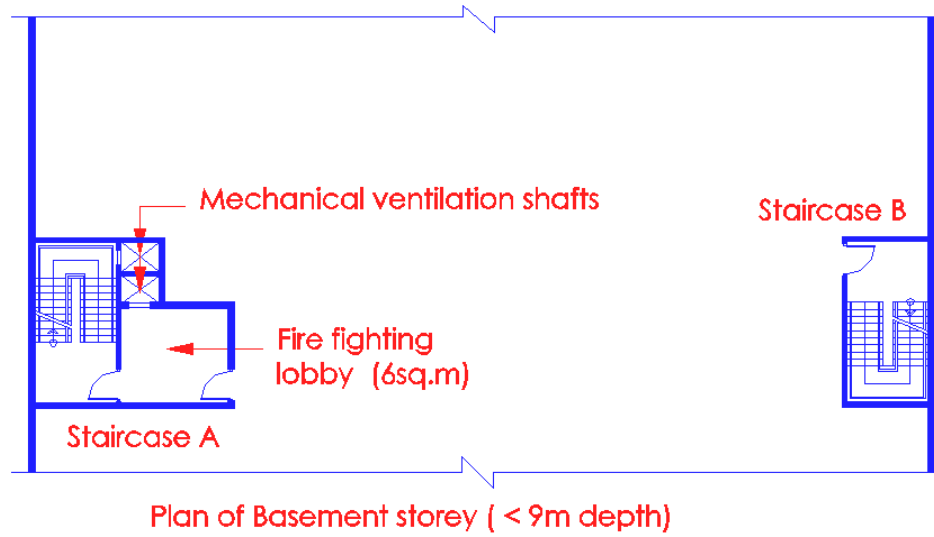

Diagram 2.2.14 (b) - 1

Only one staircase requires smoke stop lobby, which shall serve as fire fighting lobby. The protected lobby area serves as a staging area for the fire fighters when using the rising main for fire fighting.

Basement storey $\geq 9m$ depth

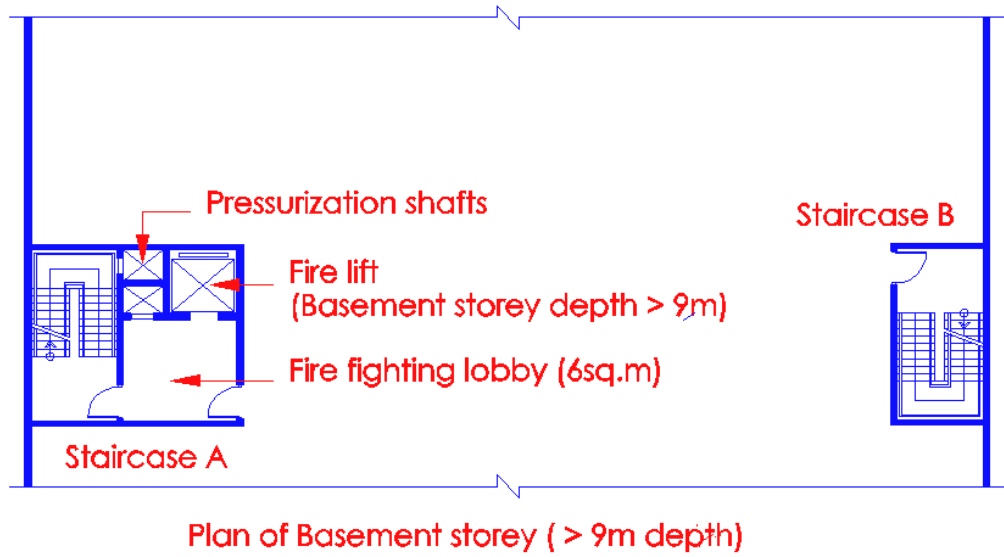

Diagram 2.2.14(b) - 2

Only one staircase requires smoke stop lobby, which shall serve as fire fighting lobby. Also refer to clause 6.6.3. which requires fire lift and fire fighting staircase to be provided.

- (c) Smoke-stop lobbies in basement occupancies shall be required to comply with the relevant provisions under Cl. 2.2.13(b) and shall be mechanically ventilated to comply with the requirements in Chapter 7.

(No illustration). Please refer to Chapter 7.

Area of refuge and exit reduction

2.2.15 When a floor area has access to Area of Refuge in compliance with following requirements in this Clause, the occupant load for which vertical exits are to be accounted for the floor area may be reduced to half when one Area of Refuge is provided and to one-third when two or more Areas of Refuge are provided.

- (a) Area of Refuge shall be :
 - (i) Adequate in size to hold the occupant load it receives from the floor area it serves as provision for required exit, in addition to its own occupant load calculated on the basis of 0.3 m² per person; and
 - (ii) Provided with at least one staircase for use by the occupants to gain access to other exit staircases or the ground level directly to an exterior open space; and
- (b) An Area of Refuge shall be entered through an external corridor and the room or space or Area of Refuge shall be separated from the corridor by a wall with minimum 1 hour fire resistance and
- (c) External corridors when used as entry into an Area of Refuge shall conform to the requirements of external exit passageway for minimum width, changes in floor level, roof protection, enclosure on the open side and provision of opening of wall between the room or space and the exit passageway, and
- (d) Exit doors between the room or space or Area of Refuge and the external corridor shall have fire resistance of at least half an hour and fitted with automatic self-closing device to comply with the requirements of Cl. 3.9.2, and

- (e) Every fire compartment in which exit reduction is permitted in connection with Area of Refuge shall have in addition to exit through the Area(s) of Refuge at least one staircase complying with Cl.2.3.3.

(See cl.1.2.4 and sub-clause 2.2.6(f) for illustration).

2.3 MEANS OF ESCAPE-GENERAL

2.3.1 General

Means of escape shall be provided for all buildings by one or more of the facilities listed herein. Access and exit facilities not specifically covered in this Code shall not be used without the approval of the Relevant Authority. Required exits shall be kept readily accessible, and doors shall be openable and unobstructed at all times during the occupancy of the building.

2.3.2 Exit passageways

(a) Fire resistance

Exit passageways that serve as a means of escape or required exits from any building or storey of a building shall have the requisite fire resistance as specified under Cl. 3.3.

(No illustration). Please refer to Cl.3.3 for details.

(b) Internal exit passageway

- (i) an internal exit passageway which serves as required exit of the building shall be enclosed with construction complying with the provisions of Cl. 3.3, and
- (ii) the enclosure walls of an exit passageway shall have not more than two exit doors opening into the exit passageway, and
- (iii) exit doors opening into an exit passageway shall have fire resistance rating as required for exit doors opening into exit staircases, fitted with automatic self-closing device and complying with the requirements of Cl. 3.9.2 for fire resisting doors, and

- (iv) the minimum width and capacity of exit passageway shall comply with the requirements as provided in Table 2.2A, and
- (v) changes in level along an exit passageway requiring less than two risers shall be by a ramp complying with the provisions under Cl.2.3.8, and
- (vi) if the exit staircase which connects to the internal exit passageway is pressurised, the internal exit passageway shall not be naturally ventilated but shall be mechanically ventilated, and it shall be pressurised to comply with the requirements in Chapter 7.

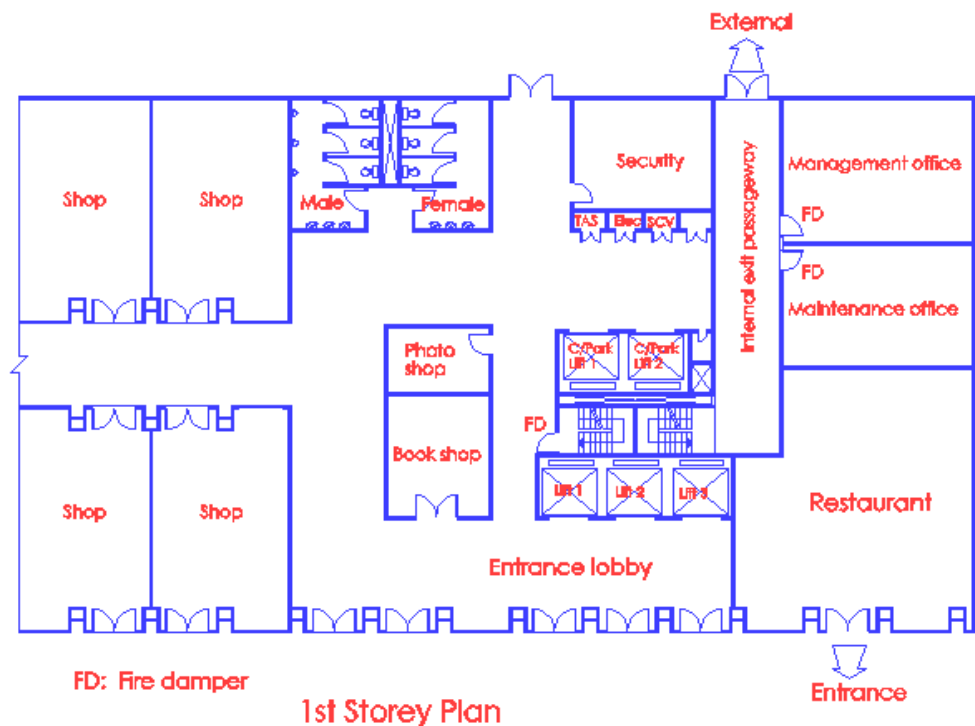

Diagram 2.3.2(b)

In the above diagram, the internal exit passageways serve as an extension to the exit staircase so that at least one of the 2 exit staircases discharges into the exterior at 1st storey. As the measurement of travel distance ends at the point of entry into it, the enclosing structural elements of the internal exit passageways shall have the same degree of protection as the exit staircase shaft it is linking. Internal exit passageways are also used when travel distances to exit staircases, stipulated in Table 2.2A cannot be met. The number of door opening directly into the staircase shaft or exit passageway at each storey shall not exceed 2 doors. In the above diagram, the 2 doors refer to the doors to the management and maintenance offices.

Where the exit passageway is provided with an internal straight ramp, the slope of the ramp shall not be steeper than 1 in 10. For pressurization of exit staircase and internal exit passageway, please refer to chapter 7 for illustration.

The requirements given in the above subclauses are illustrated in Cl.1.2.26 of Vol. 1.

2.3.2 (c) External exit passageway

- (i) an external exit passageway may be used as a required exit in lieu of an internal exit passageway, provided that the external wall between the exit passageway and the rest of the floor space may have ventilation openings of non-combustible construction, fixed at or above a level 1.8m, measured from the finished floor level of the passageway to the sill level of the openings and such ventilation openings shall be located not less than 3.0m from any opening of an exit staircase, and
- (ii) an external exit passageway may not be subjected to the limitations of a maximum of two exit doors opening into the exit passageway, and
- (iii) an external exit passageway may be roofed over provided the depth of the roofed over portion shall not exceed 3m to avoid smoke logging, and

- (iv) an external exit passageway may be enclosed on the open side by only a parapet wall of not less than 1.0 m or more than 1.1m in height and the vertical height of the unobstructed ventilation opening measured from the parapet wall up to the top edge of the opening or eaves of overhang shall not be less than 1.2m, and
- (v) exit doors opening into an external exit passageway shall have fire resistance for at least half an hour and fitted with automatic self-closing device.

(No illustration)

The above requirements are illustrated and explained in Cl.1.2.30 of Vol. 1 and Cl.2.2.13 (a).

- (d) Ventilation
 - (i) all internal exit passageways shall be naturally ventilated by fixed ventilation openings in an external wall, such ventilation openings being not less than 15 per cent of the floor area of the exit passageway, and
 - (ii) internal exit passageways that cannot be naturally ventilated shall be mechanically ventilated to comply with the requirements in Chapter 7.

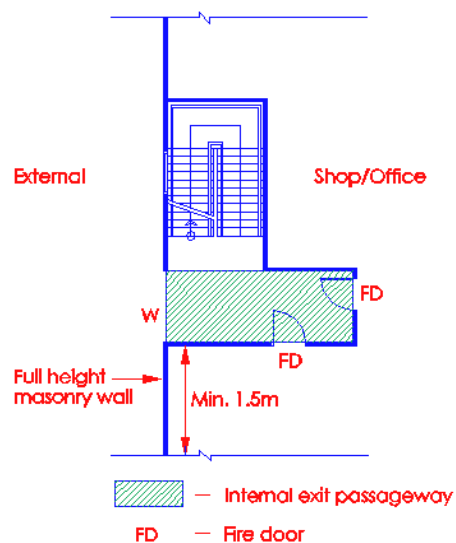

Diagram 2.3.2(d)

Natural ventilation shall be provided to all internal exit passageways. Window openings (W) shall not be less than 15% of the floor area of internal exit passageway shown above. Where internal exit passageway cannot be naturally ventilated, mechanical ventilation shall be provided to comply with Chapter 7. There shall be not more than 2 exit doors opening into the internal exit passageway.

2.3.3 Exit Staircase

(a) Internal Exit Staircase

- (i) an internal exit staircase which serves as the required exit of the building shall be enclosed with construction complying with the provisions of Cl. 3.8, and

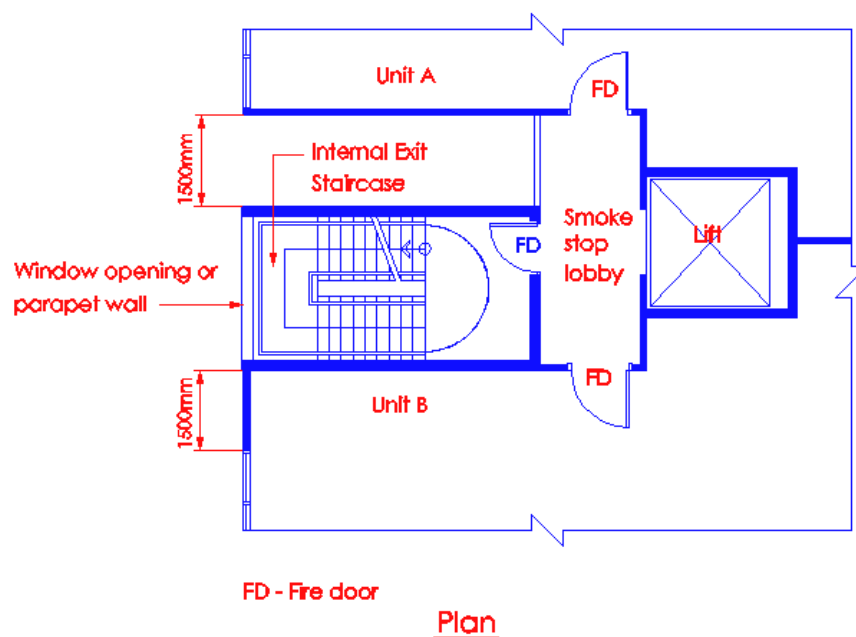

Diagram 2.3.3

No unprotected openings of occupancy area within 1.5m horizontally from window opening of internal staircase.

- (ii) where an internal exit staircase is directly approached from an external exit passageway or external corridor, it shall not be necessary to provide such enclosure between the staircase and the external exit passageway or external corridor; and

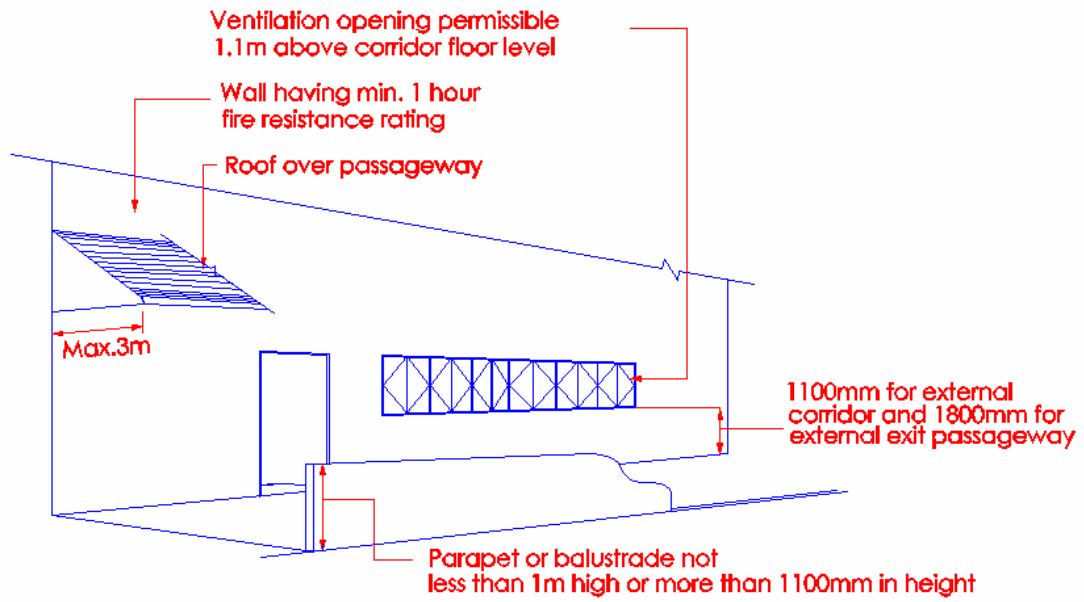

Diagram 2.3.3(a)(ii)-1

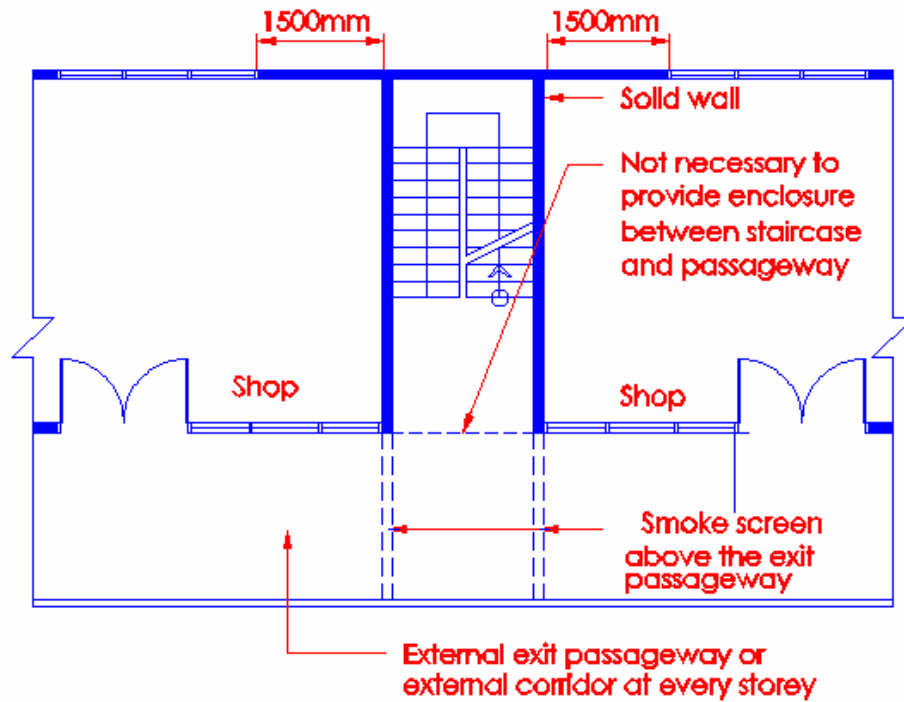

Diagram 2.3.3(a)(ii) -2

(iii) Unprotected openings

There shall be no unprotected openings of occupancy area within 1.5m horizontally or within 3m vertically below any part of the ventilation openings located in the external wall of the internal exit staircase.

Cross-ventilated exit staircase to L shape block with external corridor approach.

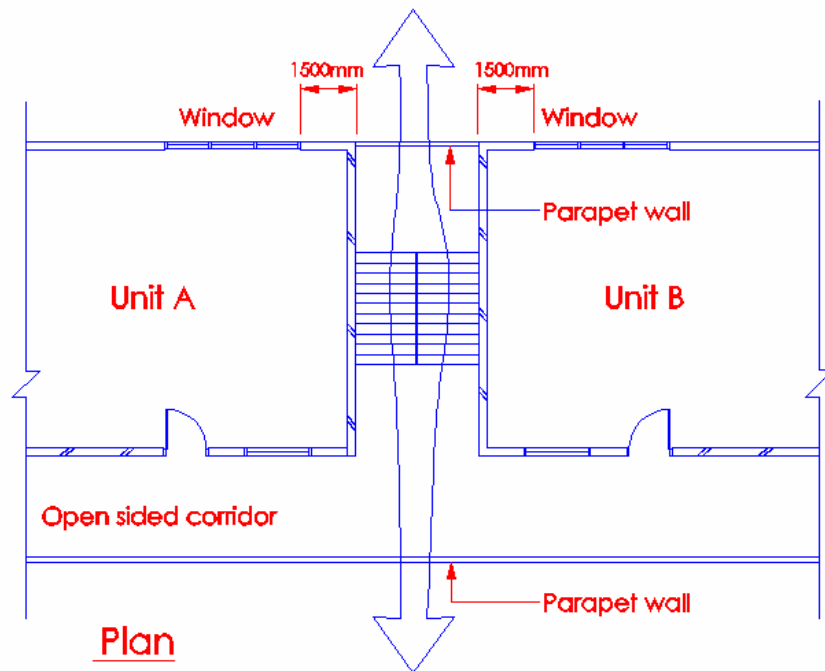

Diagram 2.3.3 (a)(iii) - 1

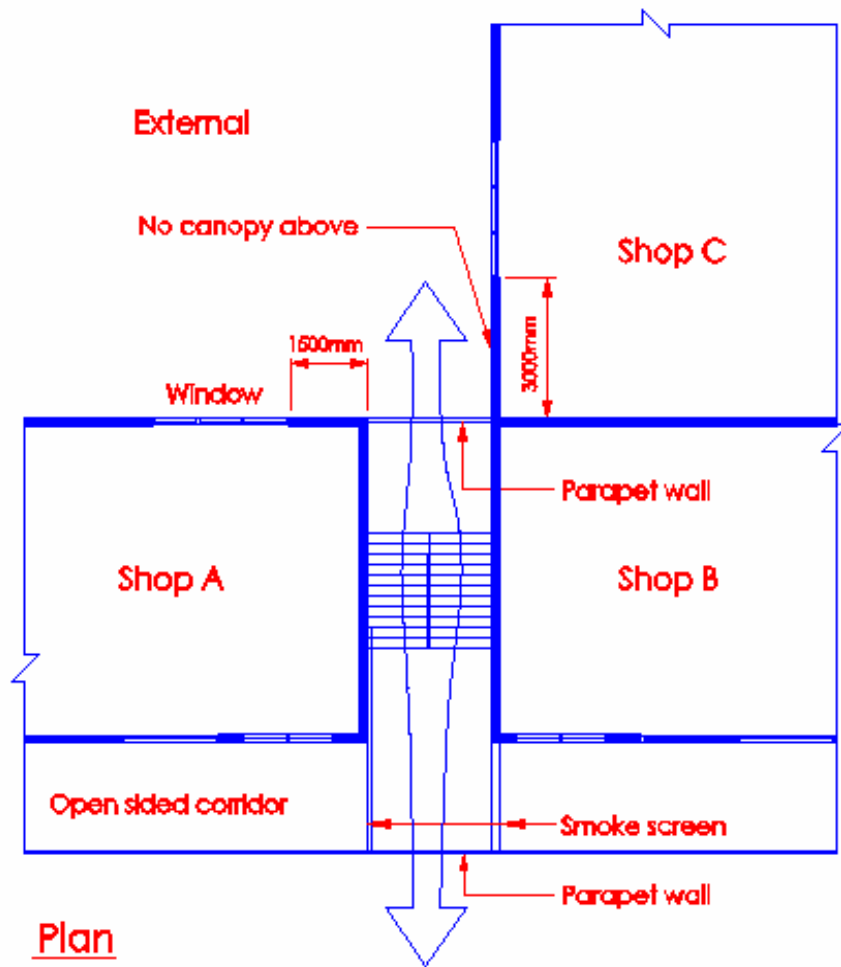

Diagram 2.3.3 (a) (iii) - 2

Cross ventilation provided to staircase will help to disperse smoke more readily. No unprotected openings from the shop units should face or ventilate into the exit staircase enclosure. The rear portion of shop unit C shall have 3m blank wall next to the staircase, otherwise smoke could be channelled into the staircase where there is a fire in the shop.

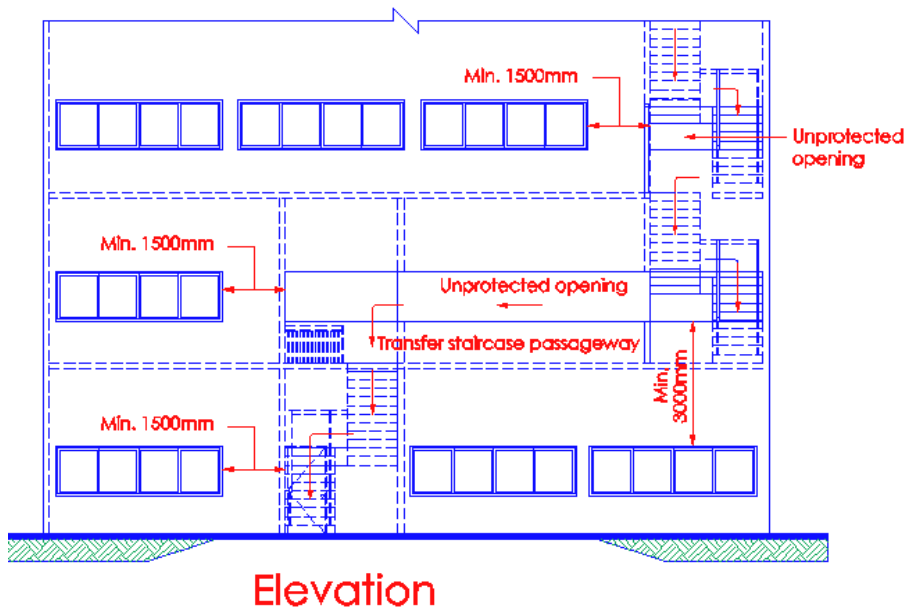

Diagram 2.3.3(a)(iii) - 3

Unprotected openings of external wall to staircase.

2.3.3 (b) External Exit Staircase

- (i) external exit staircase may be used as required exit in lieu of internal exit staircase provided it complies with the requirements of exit staircase, except for enclosure of an internal staircase, and

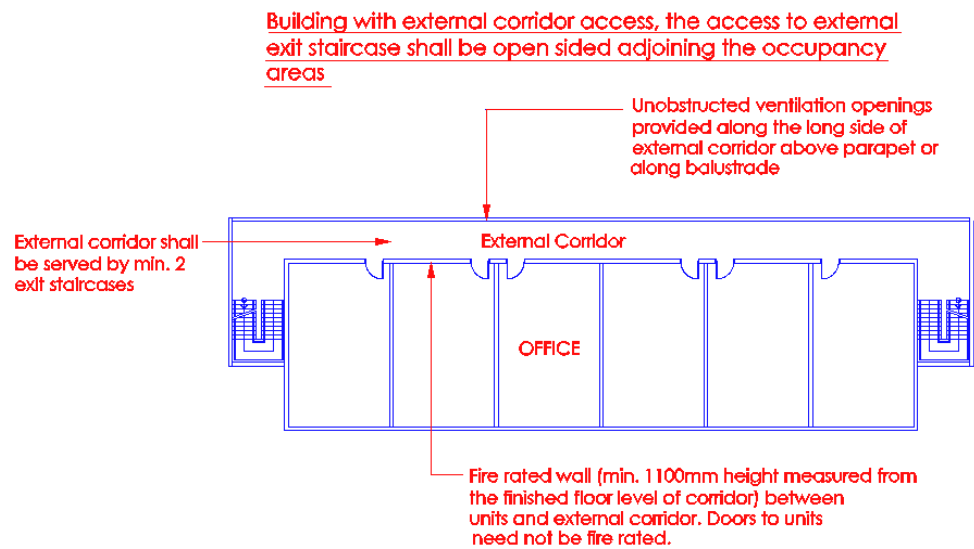

Diagram 2.3.3(b)(i)-1

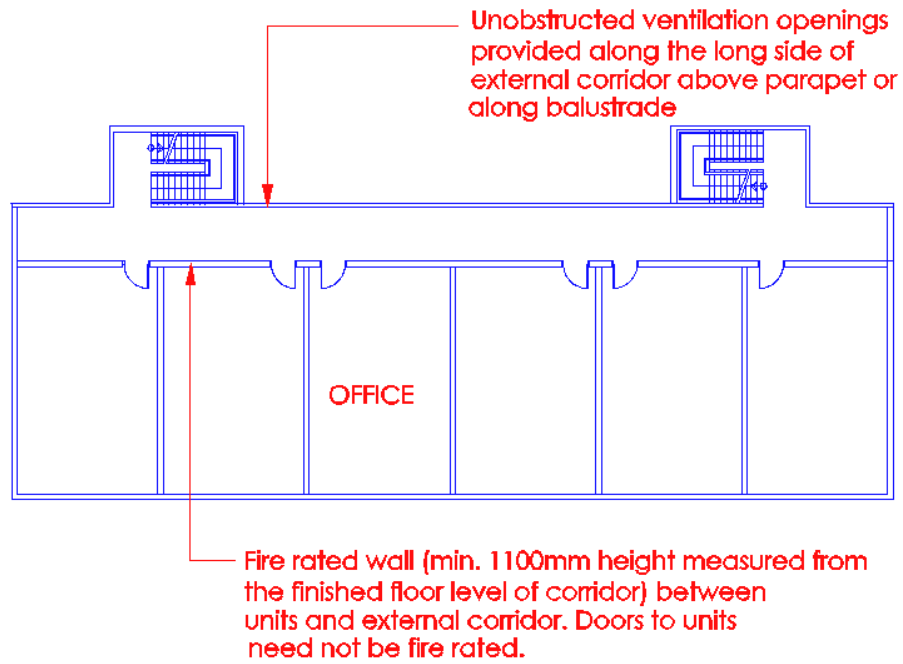

Diagram 2.3.3(b)(i)-2

- (ii) there shall be no unprotected openings within 3 m horizontally or within 3 m vertically below, or adjacent or facing (unless there is adequate separation complying with cl.3.5) any part of the external exit staircase; and

Exception:

In building designed with external corridor access, the access to the external exit staircase shall be permitted by means of the open sided external corridor adjoining the occupancy areas, subject to the following :

- (a) the external corridor shall be served by at least 2 exit staircases; and
 - (b) that unobstructed ventilation openings shall be provided along the long side of the external corridor above the parapet or balustrade.
- (iii) the external exit staircase shall be located so as to lead directly to a street or open space with direct access to street.

Protection of external staircase

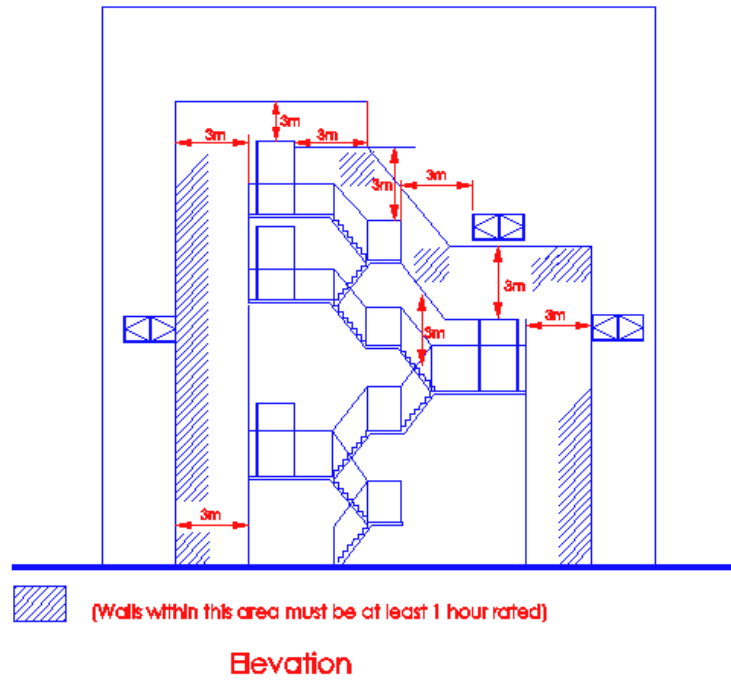

Diagram 2.3.3(b)(ii) – 1

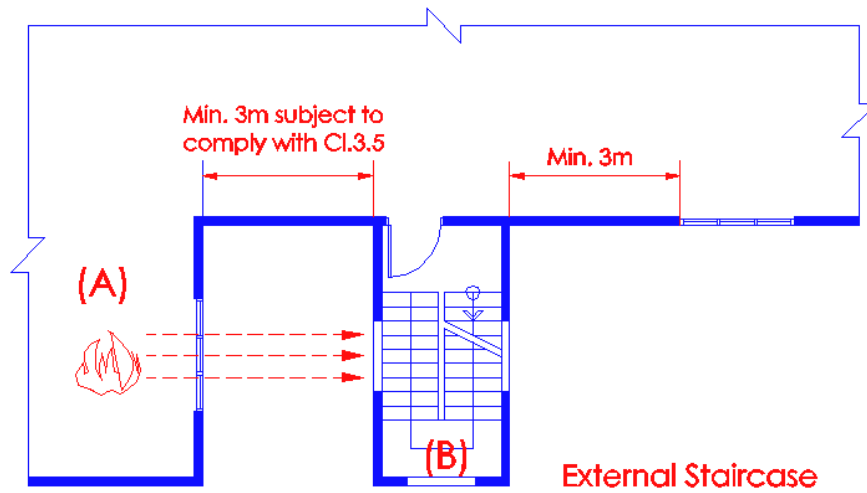

Diagram 2.3.3(b)(ii) – 2

Heat radiation from a fire through external window in part of the building at (A) would affect occupants escaping down the external staircase at (B). To avoid this situation, the separation distance between that part of the building and the staircase shall comply with the separation requirements under CL. 3.5.

CL. 3.5 would prescribe the separation distance between that part of the building (A) and the external staircase (B) in accordance with the amount of unprotected openings provided in the external wall to part of the building (A).

Alternatively, to omit the unprotected openings in the external wall of staircase (B) facing part of the building (A).

2.3.3 (c) Discharge

All exit staircases shall discharge at ground level directly into a safe exterior open space. However, in sprinkler protected building, maximum 50% of the total building exits may be allowed to discharge directly to the ground level circulation space subject to the following :

- (i) The discharge point of the exit staircase shall be at a location in the circulation space at ground level within sight of and with direct access to a safe exterior open space; and
- (ii) The maximum distance between the discharge point of an exit staircase and the exterior open space shall not exceed 10m.
- (iii) The clear width of the exit doors leading to the safe exterior open space shall be adequate to receive the occupant load in the 1st storey circulation space and the total number of people discharging from the internal exit staircases.

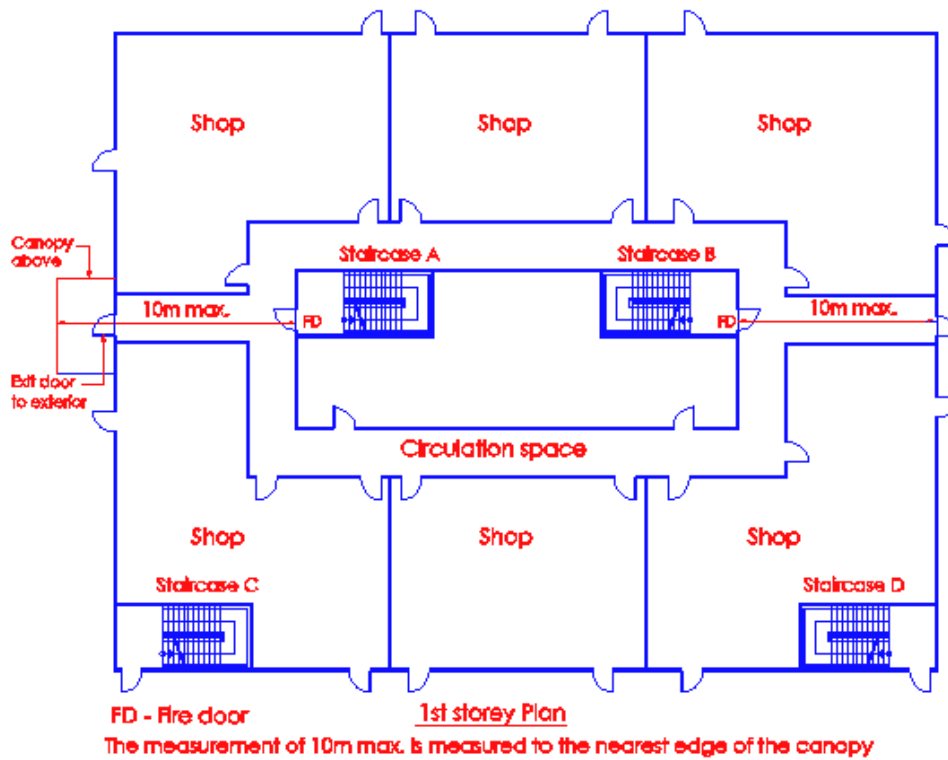

Diagram 2.3.3(c) – 1

In sprinkler protected building a relaxation is granted for 50% of the exit staircases of the building to discharge at 1st storey circulation space, subject to 3 conditions in the above sub-clause.

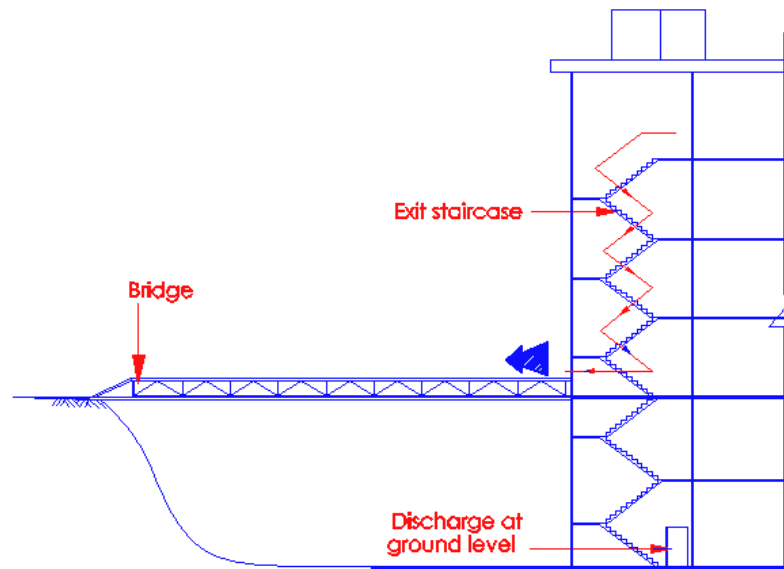

Diagram 2.3.3(c) – 2

Exit staircase is provided with discharge into unenclosed bridge leading to safe exterior space at ground level.

- (d) The minimum width and capacity of exit staircases shall be as specified in Table 2.2A, and such staircases shall comply with the following:
- (i) Winders shall not be permitted.

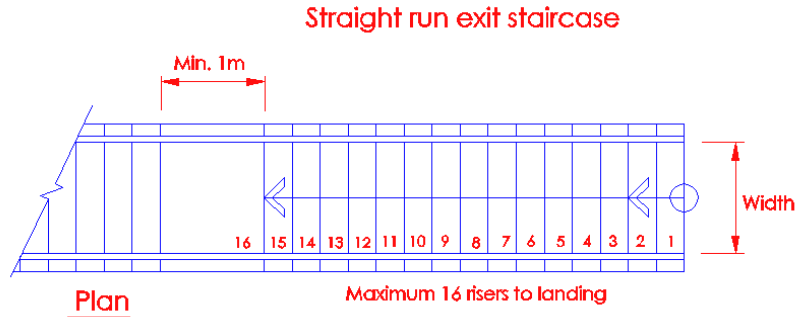

Diagram 2.3.3(d)(i) - 1

The distance between risers of the flight and lower flight shall be minimum 1m irrespective of the width of the staircase. This is to allow more standing space for occupants within the staircase when making a change from one flight of steps to another.

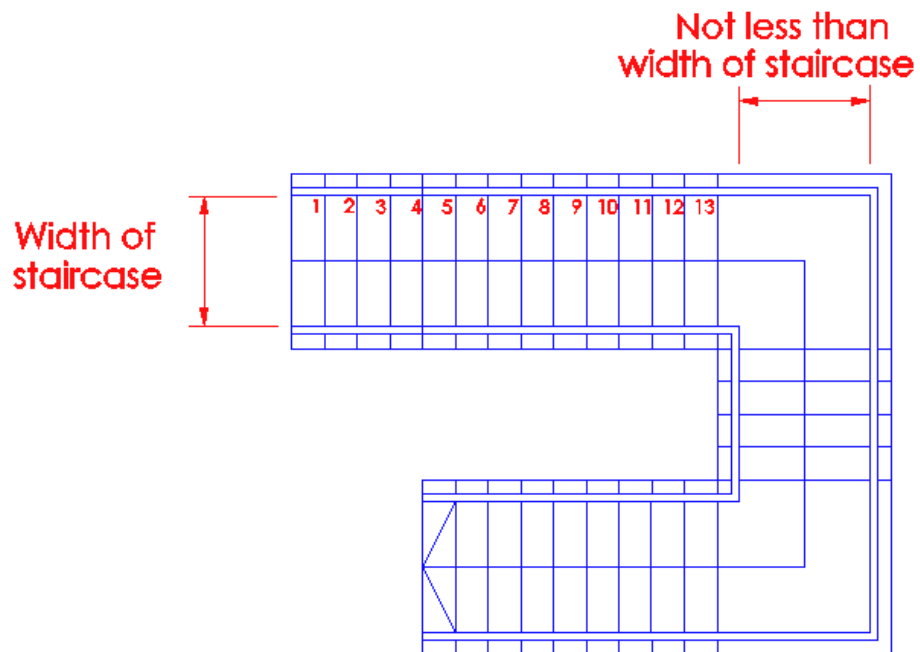

Diagram 2.3.3(d)(i) - 2

Treads for circular/ geometric staircases

- (ii) Where circular/geometric staircases are used as exit staircases, the width of treads measured at the narrower end shall be not less than 125mm and at a distance of half metre from the narrower end shall be not less than 250mm.

Circular/Geometric staircase

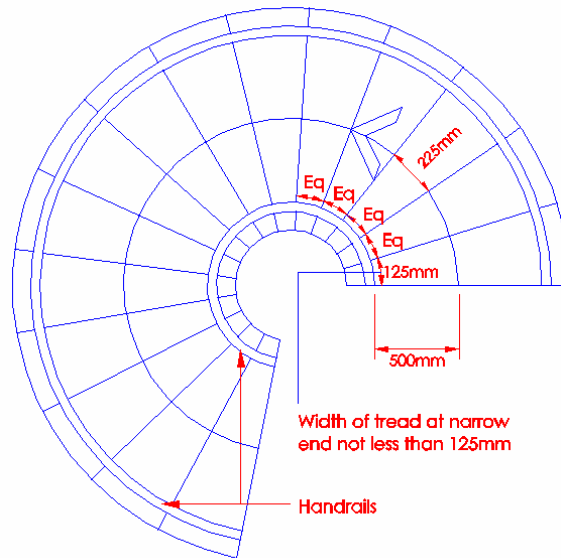

Diagram 2.3.3(d)(iv)

Circular/geometric staircases are not recommended for use as exit staircases due to their varying tread size, which can cause escaping occupants to lose footing and falling more frequently than straight run staircases. However, it may be permitted with limitations as provided for under Cl.2.3.7, or otherwise consented by the Relevant Authority.

2.3.3 (e) Handrails

Where the width of the exit staircase exceeds 2000 mm, handrails shall be provided in accordance with the requirements of Cl. 2.2.8.

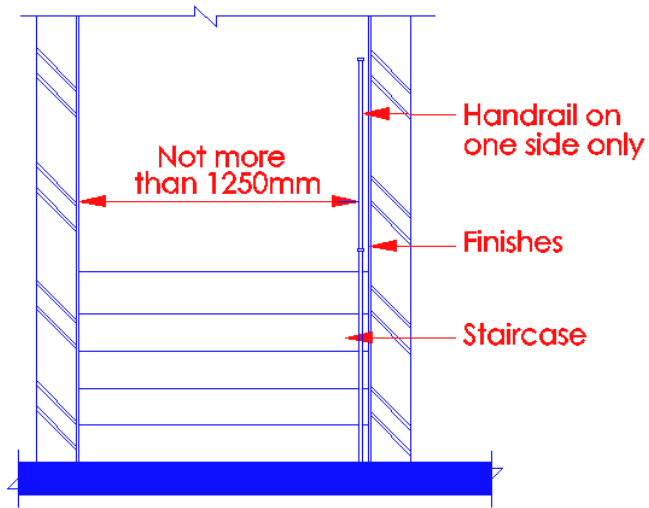

Diagram 2.3.3(e) – 1

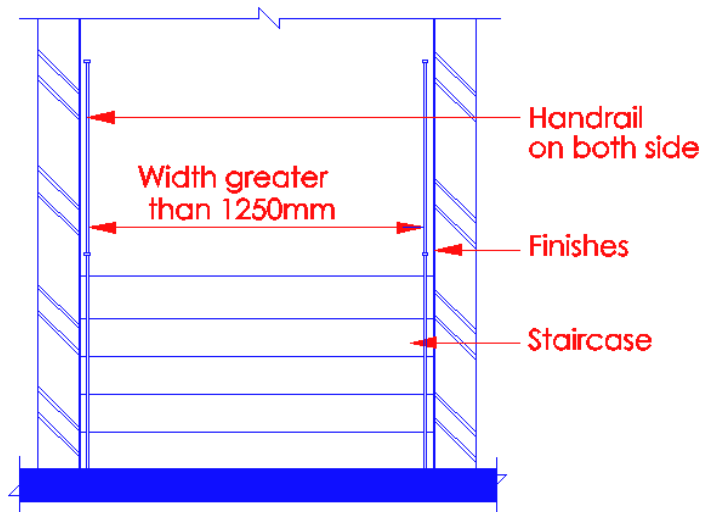

Diagram 2.3.3(e) – 2

2.3.3 (f) Ventilation

All exit staircases shall be ventilated by fixed openings in the external walls, such openings being of area not less than 10 per cent of the floor area per floor of the staircase, or mechanically ventilated to comply with the requirements in Chapter 7. Exit staircase and occupancy area shall not share the same airwell or void for lighting and ventilation.

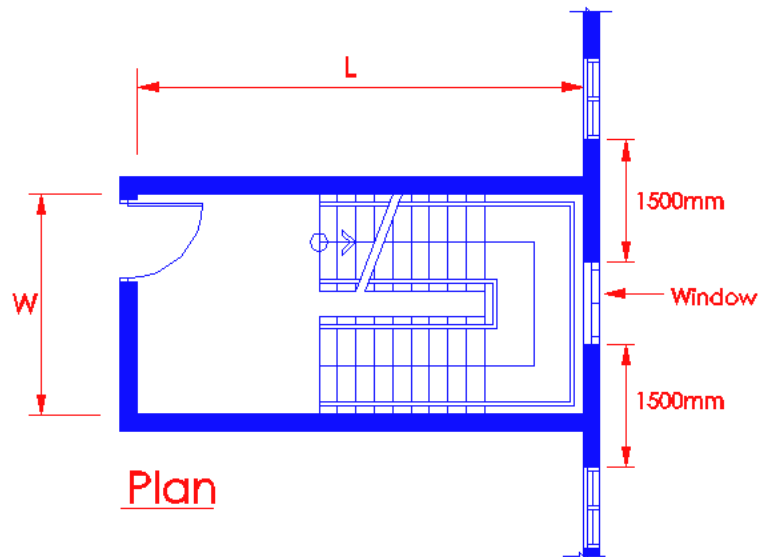

Diagram 2.3.3(f) - 1

Area of window opening shall not be less than 10% of the floor area per floor of the staircase ($L \times W$). However, mechanical ventilation to the staircase is acceptable provided requirements under Chapter 7 of the Fire Code are complied with.

Not Acceptable Ventilation Arrangement

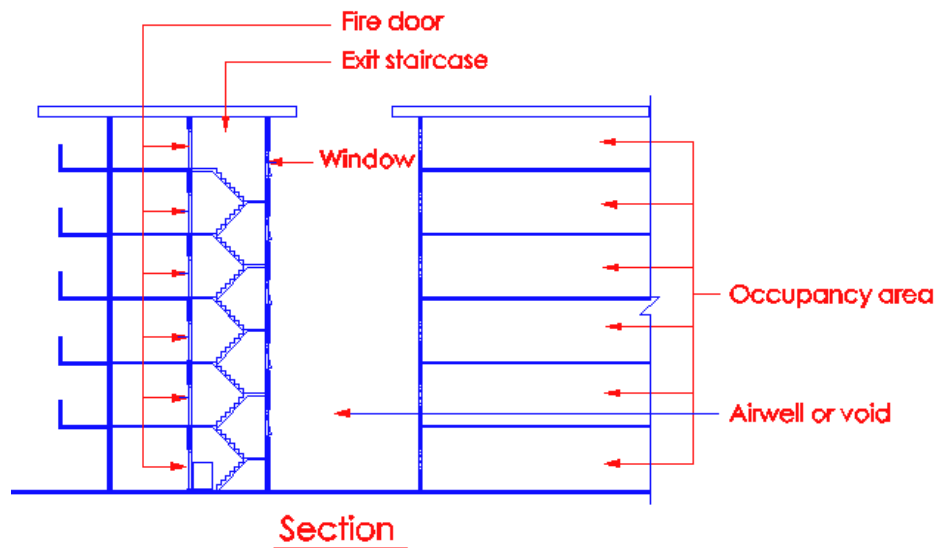

Diagram 2.3.3 (f) - 2

Exit staircase and occupancy area shall not share the same air well or void for lighting and ventilation to prevent smoke from being drawn into the staircase.

2.3.3 (g) Pressurisation

In any building of which the habitable height exceeds 24 m, any internal exit staircases without provision for natural ventilation shall be pressurised to comply with the requirements in Chapter 7. In a building comprising more than four basement storeys, the exit staircase connecting to the fire fighting lobby shall be pressurised.

For illustrations please referred to Cl.2.2.13 and Cl.2.2.14.

In addition to the provision of pressurisation, the entry into the internal staircase shall be through a smoke stop lobby. The smoke stop lobby acts as a buffer zone for the effective operation of the pressurisation system to the staircase.

2.3.4 Scissors Exit Staircase

- (a) Where two separate internal exit staircases are contained within the same enclosure, each exit staircase shall be separated from the other by non-combustible construction having fire resistance for a minimum period equal to that required for the enclosure, and
- (b) Such scissor exit staircases shall comply with all applicable provisions for exit staircase.

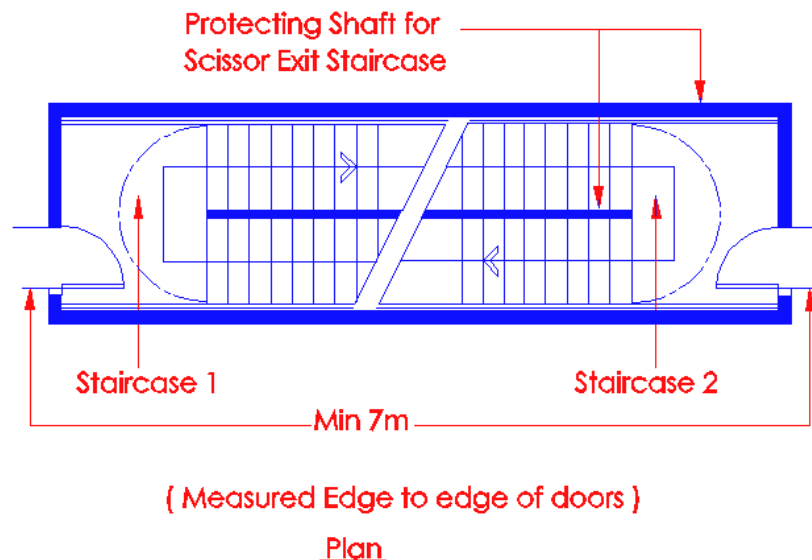

Diagram 2.3.4 – 1

Door opening into scissors exit staircases shall be at least 5m distance from each other. The separation distance shall be measured alongside the wall. With adequate separation, a fire occurring near one staircase exit will not affect the escape route leading to the other staircase exit.

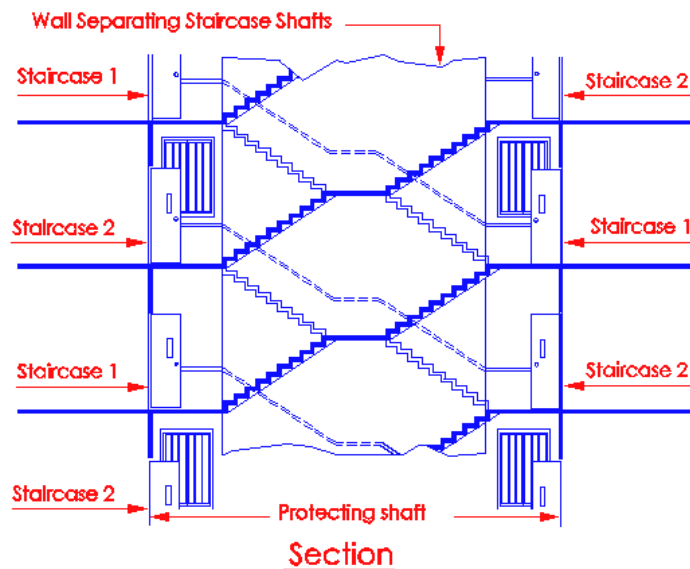

Diagram 2.3.4 – 2

- (1) Scissors staircases shall comply with cl.2.3.3 for internal staircases;
- (2) Doors opening into scissors exit staircases shall be spaced at least $\frac{1}{3}$ or $\frac{1}{2}$ the diagonal dimension of the building or area to be served in sprinkler or non-sprinkler protected building respectively under cl.1.1.60 and subject to a minimum of 5m.
- (3) Windows for ventilation should preferably be located on alternate storeys such that window serving the same staircase will appear on the same side so that if one staircase gets 'smoke-locked', the smoke would not spread into the other staircase through window opening.

2.3.4 (c) Door opening into scissor exit staircases shall be at least 7m travel distance from each other.

2.3.5 Basement Exit Staircase

- (a) Any exit staircase which serves a basement storey of a building shall comply with all the applicable provisions for exit staircase, and
- (b) Such exit staircase shall not be made continuous with any other exit staircase which serves a non-basement storey of the building, and

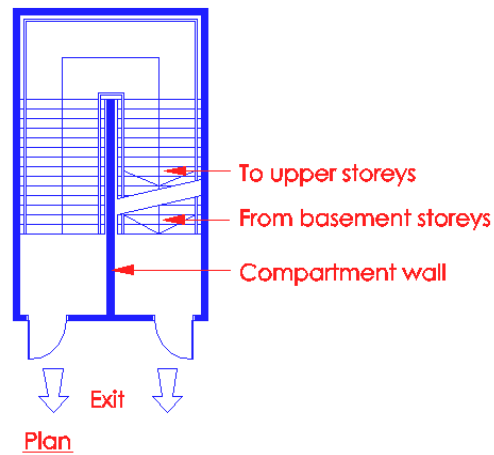

(c) Separate protected shaft

Basement exit staircases, which are vertically aligned with the exit staircases of non-basement storeys, shall be separated from such other exit staircases by construction having fire resistance for a minimum period equal to that required for the enclosure.

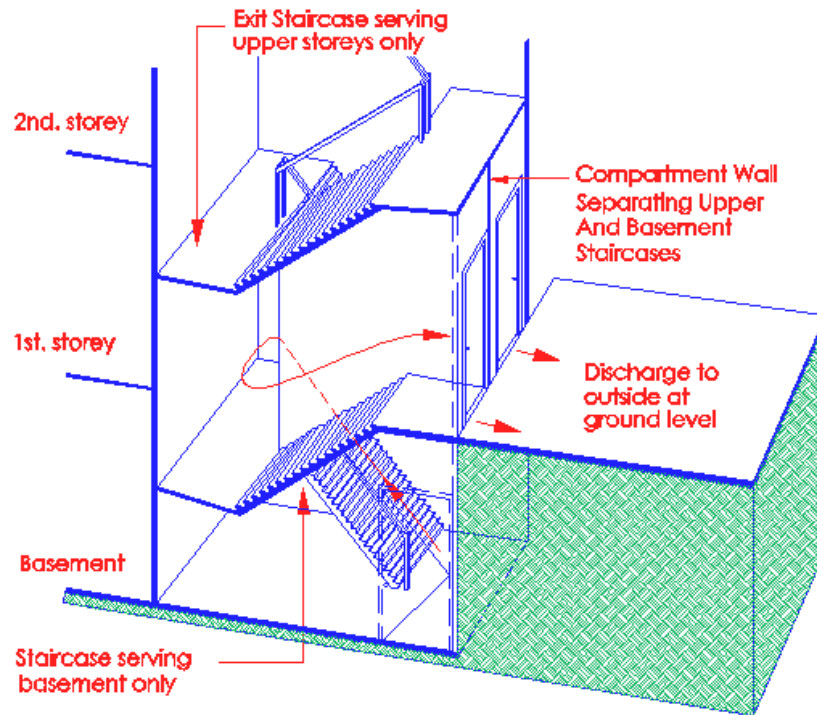

Diagram 2.3.5(c)

The provision of compartment wall is to separate the basement staircase from the above ground staircase so that each is located in a separate shaft.

2.3.5 (d) Upper storey staircase continue into basement

Where upper storey staircase is allowed by the Relevant Authority to be continuous with that serving the basement which is naturally ventilated, the following shall be complied with:

(i) Entry at basement

the entry into the basement staircase shall be through a protected lobby or directly from the basement occupancy area, provided the door to the basement staircase is minimum 1-hour fire rated;

(ii) Barrier

to prevent occupants exiting continuously from upper storeys into the basement floor during an emergency, a physical barrier in the form of a door or gate could be provided across the staircase landing at ground level to separate the discharge route of upper storeys from the basement staircase;

Applicable only if staircase serves 4 storeys or less and entry into the staircase from the basement car park is through a 1 hour rated fire door

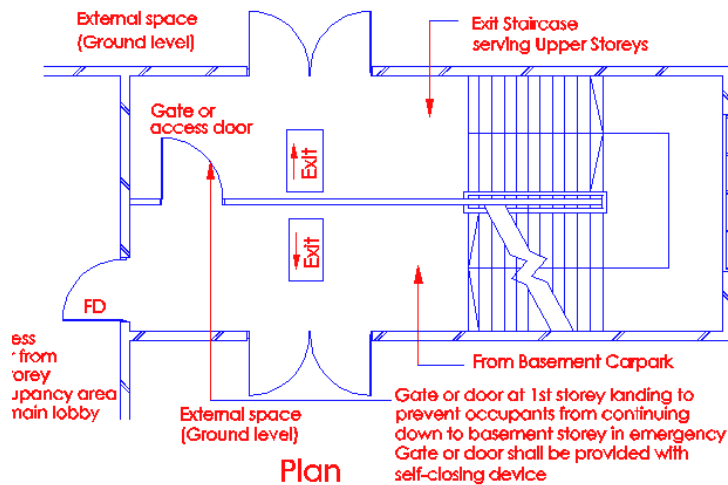

Diagram 2.3.5(d)(ii)

Interruption of Exit Stair at Level of Exit Discharge.

This can be done by placing a physical barrier, like the gate shown above, to prevent occupants from continuing to the basement in emergency. This, together with the aid of exit directional sign, helps to alert occupants in the stair enclosure that they are on the level of exit discharge.

(iii) Smoke stop lobby

smoke stop lobby shall be provided for entry into the staircase at all storeys, including basement if the staircase serves more than 4 storeys, including basement;

(iv) Signages

appropriate signage shall be provided inside the staircase enclosure to direct occupants out of the building at ground level.

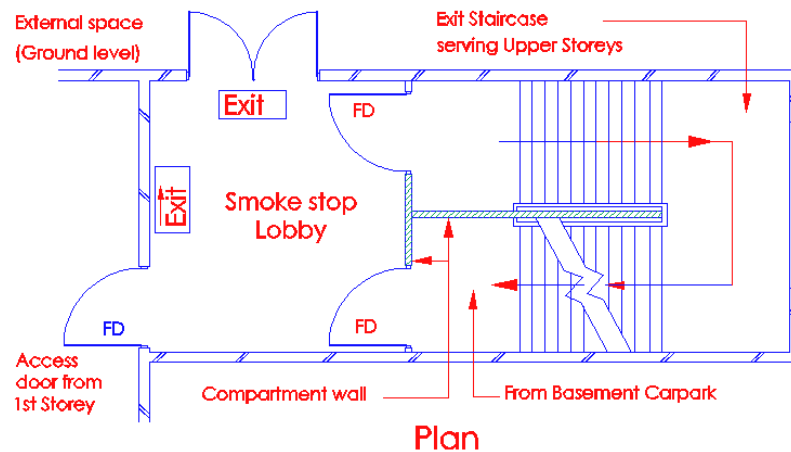

Diagram 2.3.5(d)(iii)

- 2.3.6 (a) Hardwood staircase shall be allowed to be used as internal access staircase in building.

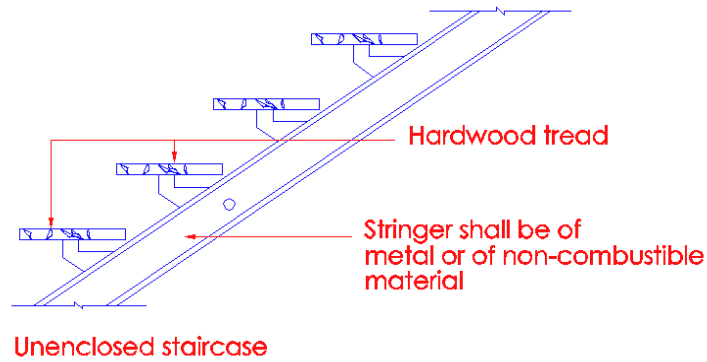

Diagram 2.3.6

As stringer is considered as part of an element of structure, it shall be of non-combustible material having the necessary fire resistance rating of ½ hour or 1 hour as the case may be under clause 3.3

2.3.7 Spiral Staircases

- (a) Spiral staircases shall not serve as required exits except that external unenclosed spiral staircases when built of non-combustible materials and having a tread length of at least 750 mm may serve as required exits from mezzanine floors and balconies or any storey having an occupant load not exceeding 25 persons, and
- (b) Such spiral staircases shall be not more than 10 m high.

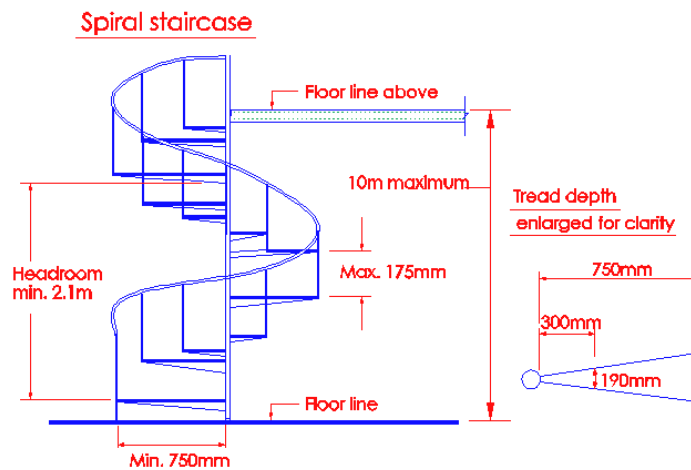

Diagram 2.3.7

Minimum and maximum dimensions for spiral stairs are shown above. All treads must be identical, and the stair can serve a maximum occupant load of 25 persons.

Spiral staircase is slightly different from curved or other geometric staircases, as all its treads must be identical, subject to a height restriction of 10m and being located on the external facade of the building to qualify as exit staircase.

As spiral staircase is very steep and winding, the time taken by occupants to exit downward during an emergency would be much longer, hence there is a need to limit the occupant load to max. 25 persons. In permitting the spiral staircase to be used as exit staircase in case of fire, and for rescue and fire fighting operations by fire fighters, the width of the staircase should not be less than 750mm. This width would be just adequate to permit movement of fire fighters in full body gear and carrying casualties in moving down the stair.

2.3.8 Exit Ramp

Internal and external exit ramps may be used as exits in lieu of internal and external exit staircases subject to compliance to the applicable requirements of Cl.2.3.3 and to the following:

(a) Slope

The slope of the ramp shall not be steeper than 1 in 10, and

(b) Changes in direction

The exit ramps shall be straight with changes in direction being made at level platforms or landings only, except that exit ramps having a slope not greater than 1 in 12 at any place may be curved, and

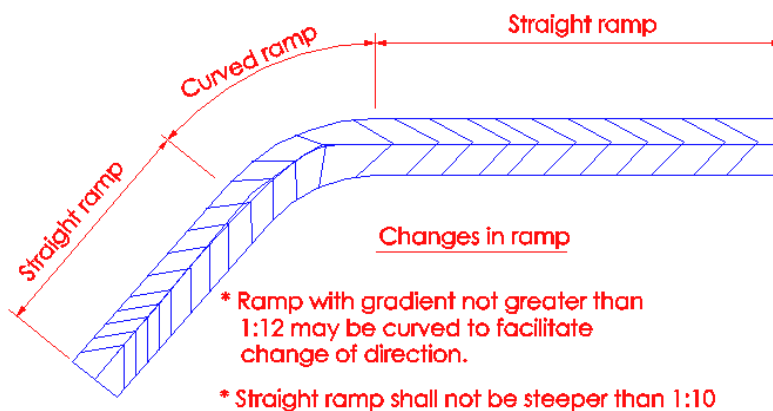

Diagram 2.3.8(b) - 1

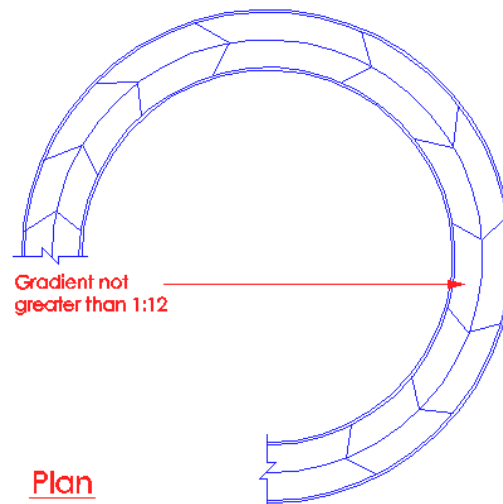

Diagram 2.3.8(b) - 2

Circular ramp having a gradient not greater than 1:12 is acceptable as an exit ramp.

(c) Platform

- (i) level platforms or landings shall be provided at the bottom, at intermediate levels where required and at the top of all exit ramps, and
- (ii) level platforms shall be provided at each door opening into or from an exit ramp, and
- (iii) the minimum width of a platform or landing and length shall be not less than the width of the ramp, except that on a straight-run ramp, the length of the level platform or landing need not be more than 1 m, and

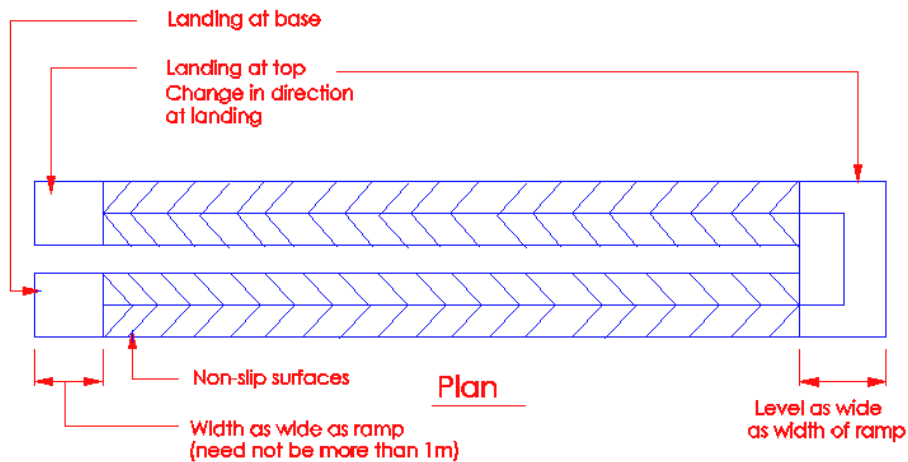

Diagram 2.3.8 (c)

The minimum width for the landing is to be 1m irrespective of the width of the ramp.

2.3.8 (d) Guards and handrails

Exit ramps shall have walls, guards or handrails and shall comply with the applicable requirements of Cl.2.3.3(d) for exit staircases, and

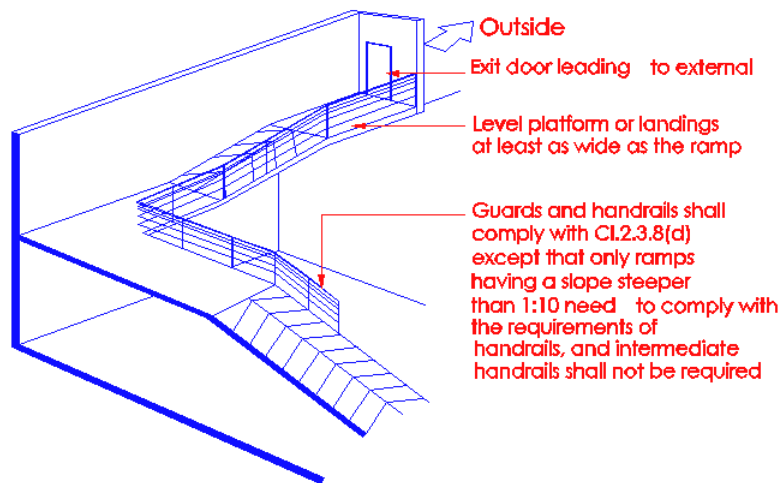

Diagram 2.3.8(d) & (g)

The above clause applies only to ramp serving one level. Occupants using the exit ramp, shown in diagram 2.3.8(d), would be able to travel at a quicker pace to exit directly into the exterior space at grade level. As only one level is involved and that final exit is within sight of exiting occupants, there is no need to protect the ramp with enclosure walls, provided travel distance is measured to the door at grade level and comply with Table 2.2A.

All exit ramps shall be constructed of non-combustible materials to have the necessary fire resistance rating as exit staircase. Similarly, the width of the exit ramp shall have the adequate exit capacity to receive the occupant load from the floor space it serves.

2.3.8 (e) Surface

All exit ramps shall be provided with non-slip surface finishes, and

(No illustration)

(f) Ventilation

Exit ramps shall be ventilated to comply with the requirements for ventilation of exit staircases, and

See Cl.2.3.3(f)

(g) Enclosure exemption

Exit ramps, serving as means of escape to only one basement storey, need not be protected by enclosure walls.

See Diagram 2.3.8(d) & (g) for illustration.

2.3.9 Exit doors and exit access doors shall comply with the following:

(a) Exit doors shall be capable of being opened manually, without the use of a key, tool, special knowledge or effort for operation from the inside of the building; and

(b) Exit doors which are required to have fire resistance rating shall comply with the relevant provisions for fire resisting doors under cl.3.9.2; and

Door swing

2.3.9 (c) Exit doors and exit access doors shall open in the direction of exit travel:

(i) when lead to an area of refuge and exit passageway, or

- (ii) when used in exit closure, including smoke stop and fire fighting lobbies in a building. It shall not apply to doors of individual residential units that open directly into an exit enclosure, or
 - (iii) when serving a high hazard area, or
 - (iv) when serving a room or space with more than 50 persons, and
- (d) (i) Exit doors opening into exit staircases and exit passageways shall not impede the egress of occupants when such doors are swung open, and

Door opening into corridor

- (ii) All doors which open into the corridor shall not hinder movement of occupants. The corridor's clear width shall at least remain to be half of the required clear width as stipulated under Table 2.2A when such door(s) is swung open.

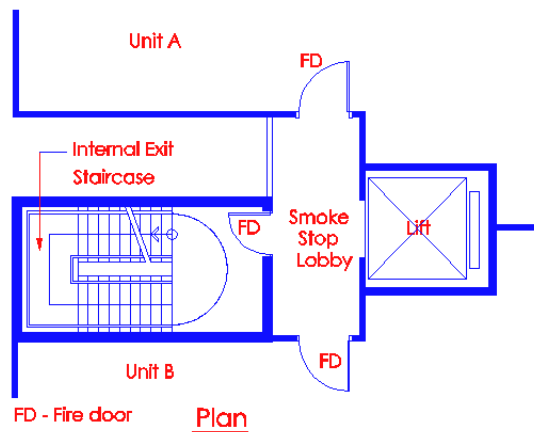

Diagram 2.3.9

- (1) Exit door opening into the exit staircase shall satisfy the requirements above. The dotted lines indicate the space that would be used by occupants exiting in the staircase.
- (2) Exit doors to units A & B in the diagram 2.3.9 are shown to open inward. It is allowed if the exit door does not serve a room or space with more than 50 persons.

(3) Where an exit door consists of 2 unequal leaves, the smaller leaf may not be required to be provided with sequential closer if it is bolted in closed position, provided the clear width of opening of the larger leaf is not less than 1000mm, and able to meet the full exit capacity in terms of units of width required.

(4) Doors on escape routes

Normally a door used for means of escape should open in the direction of escape. It should always do so :-

- 2.3.9(d)
- (i) if it is from a room in which a fire may develop very rapidly eg kitchen etc; or
 - (ii) if the door is from an area from which more than 50 persons may be required to escape e.g. exit doors to auditorium, multi-purpose hall function room, etc should be kept unlocked at all times when people are in the building and should be fastened so that they can be immediately opened by persons escaping without the use of a key. The door should be fastened only by means of panic bolt or panic bolt fastening which ensures that it can be readily opened by pressure applied by occupants using the door. Panic bolts and panic latches should be properly maintained at all times.

(5) The door should also: -

- (i) be hung so that, when open, it does not obstruct any escape route;
- (ii) open through not less than 90 degrees;
- (iii) be provided with a vision panel if it is hung to swing both ways.

(6) Self-closing devices for doors

All fire doors except those to cupboards and service ducts should be fitted with self-closing devices to ensure the positive closure of the door. Generally, rising butt hinges are not acceptable. Fire doors to cupboards, service ducts and any vertical shafts linking floors should be kept locked shut when not in use.

Fastenings on doors

Generally, locking of exit door is not permitted in a building. However, owing to security reasons certain exit doors are allowed to be provided with locking mechanism, provided such doors are readily openable in the event of a fire or other emergencies.

Doors used for means of escape should be kept unlocked at all times when people are in the building and should be fastened so that they can be immediately opened by persons escaping without the use of a key.

The other means of unlocking exit doors in an emergency may be in the form of one-way locking device, eg panic bolt, thumb-turn or linking the locking device to the fire alarm system such that the activation of the alarm system would automatically release the locking mechanism.

Provision of electronic locking device such as card key access or one-way locking devices hooked to fire alarm system shall not be allowed unless otherwise permitted by SCDF (FSSD). Qualified persons shall consult SCDF (FSSD) on such provision before submission of building plans.

The various situations in which exit doors to protected staircases and fire lift lobbies or rentable spaces/rooms could be fitted with acceptable locking device are illustrated in the following diagrams :

2.3.9(d)

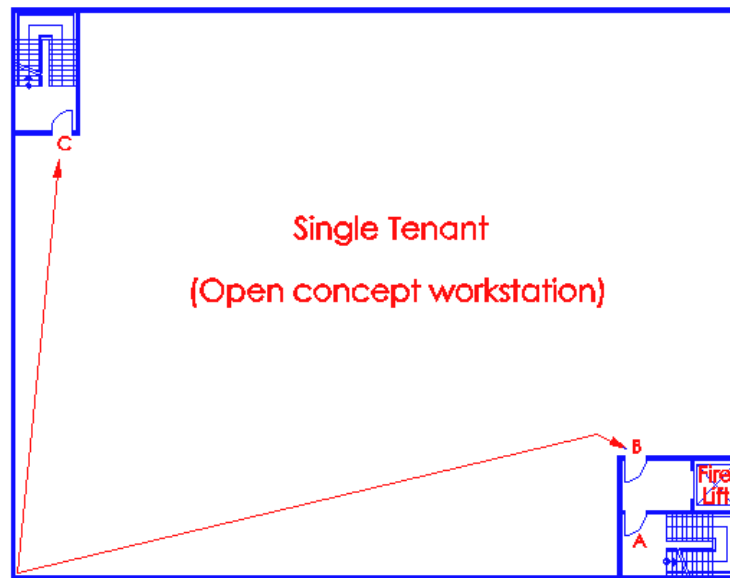

Diagram 2.3.9(d) - 1

- Door A - On-way locking device is allowed, provided it is linked to the building's fire alarm system
- Door B - C On-way locking device allowed (e.g. panic bolt, thumb turn or card access system with provision for unhindered exit in an emergency)

Multi-tenancy with no corridor

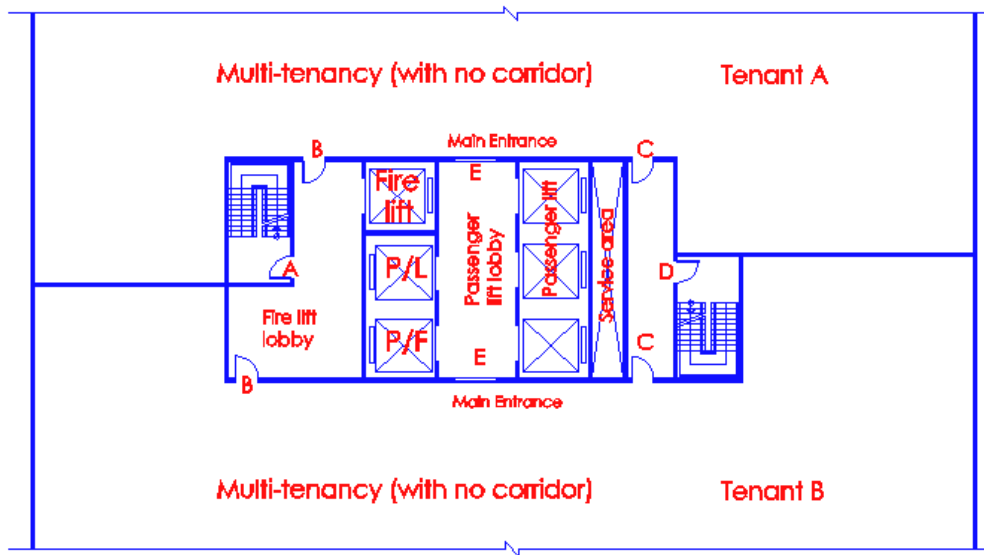

Diagram 2.3.9(d) - 2

- Doors A & D - One-way locking device allowed, provided it is linked to building's fire alarm system. (e.g. panic bolt, thumb turn, card access system with provision for unhindered exit in an emergency)
- Door B - On-way locking device allowed (door fitted with vision panel)
- Door C - On-way locking device allowed
- Door E - Locking device allowed, provided the fire wardens to ensure that persons stranded will be released and intercom system is linked to Fire Command Centre

Multi-tenancy with corridor

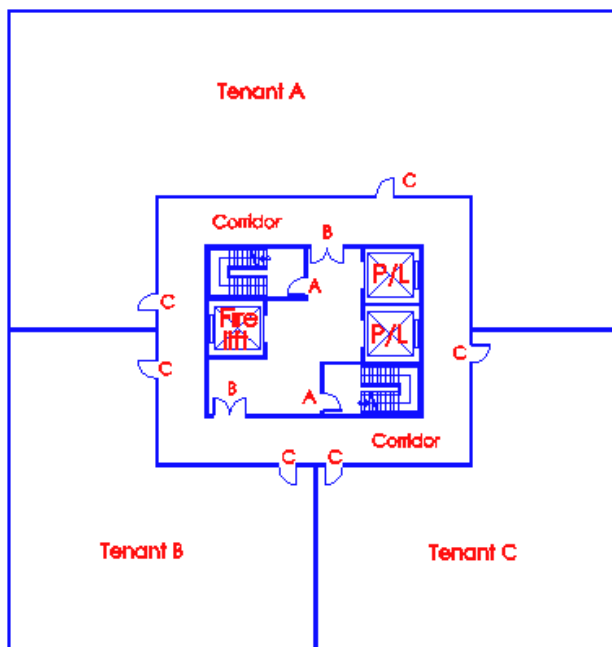

Diagram 2.3.9(6) - 3

- Doors A & B - One-way locking device allowed provided it is linked to building's fire alarm system
- Door C - One-way locking device allowed (e.g. panic bolt, thumb turn or card access system with provision for unhindered exit in an emergency)

(7) Notices on doors

A notice with the words "Push bar to open" should be permanently displayed immediately above the push-bar on all doors fitted with panic bolt or panic latch.

A notice with the words 'Fire door – Keep shut' should be permanently displayed at about eye level on both faces of all fire doors except those to cupboards. Fire doors which are normally open but which close automatically on the operation of fire detectors should bear the words 'Automatic fire door – Keep Clear' – 'Close at night' as appropriate. 'Fire door – keep shut' notice need not be displayed on the entrance door to each residential.

A notice with the words 'Fire door – Keep locked' should be permanently displayed on the outside face of all fire doors not required to be self-closing e.g. M&E shaft doors

(8) Sliding door

These are not normally suitable on escape routes unless they are convertible to outward swing doors when pushed at 90 degree to the sliding door from the interior of the building. In the case of powered/auto sliding doors they should be provided with a monitoring system to ensure that they are of fail safe type. It shall be linked to the building fire alarm system and be able to open and remain in open position during building fire alarm activation and power failure.

(9) Roller shutter

Roller shutters are not permitted as exits. Where they are used, a side exit door or by-pass exit door shall be installed next to the roller shutter.

2.3.9 (e) Vision panel

Fire door to protected staircase and smoke stop/fire lift lobby shall be constructed to incorporate a vision panel. The clear opening for installation of the vision panel shall not exceed 45,000 mm² with a clear width of minimum 150mm. The vision panel shall have the requisite fire resistance rating and shall not turn opaque when subject to heat. The vision panel shall be located with the bottom edge not lower than 1200mm and the top edge not higher than 1700mm measured from the finished floor level. The provision of vision panel shall not apply to exit doors of residential apartment or maisonette units.

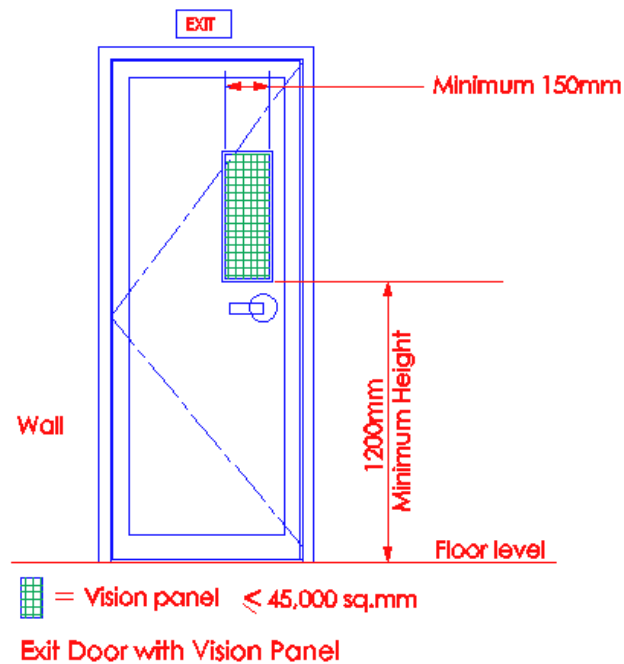

Diagram 2.3.9(e)

Glass panel must be treated together with the door. The minimum size of the glass panel shall not be less than 150mm x 150mm. The door shall bear PSB label.

- 2.3.9 (f) Revolving doors shall not be used as exit doors for required exits.

(No illustration)

Owing to the risk of jamming, conventional type revolving doors are not normally accepted as doors for means of escape purposes. Where such door is used, exit door shall be provided adjacent to it and clearly indicated with exit sign.

Side-hinged or pivoted swing door

- 2.3.9 (h) Any door located in a path of travel shall be of the side-hinged or pivoted swing type. The door shall be designed and installed so that when swung open, it does not prevent full use of the opening. The minimum clear width of the door opening shall not be less than the required door clear width.

Sliding Doors & Roller Shutters

Exception 3: Sliding door and roller shutter as listed in (i) to (iv) are permitted to be installed across the exit access or escape paths leading to exits, including the exterior door openings except in areas stipulated under cl.2.3.9(c)(i) and (iii). These doors shall not form part of the fire compartment integrity.

Manually operable sliding doors or roller shutters shall be capable of being opened and closed manually from either side of the door. The manual force required to operate the door in the direction of door travel shall not be more than 130N to set the door in motion, and 70N to close the door or open it to the minimum required width when applied at the door handle or catch/knob which is located at the opening edge of the door under still air conditions.

Manually operable sliding doors/ roller shutters

- 2.3.9 (h) (i) Manually operable sliding door or roller shutter that can remain in closed position during the period of occupation is permitted at rooms or spaces with occupant load not exceeding 50 persons. When opened, it shall not reduce the effective width/height of the doorway leading to the escape route. Sliding door or roller shutter is allowed within rooms or spaces that serve more than 50 persons provided it shall remain in the full open position during the period of occupation. A readily discernible sign with the lettering "THIS DOOR TO REMAIN OPEN WHEN THE BUILDING IS OCCUPIED" shall be permanently pasted on both sides of such sliding door or roller shutter at a height of 1.4 m from the finished floor level. The lettering shall be 25mm in height and painted in white on a red background with reflective surface, or

(No illustration)

If the occupant load to a room or space exceeds 50 persons, sliding door or roller shutter located across means of escape shall be kept in the open position during the period when the premise is occupied. The main concern is that extra effort and time would be needed to manually open the roller shutter or sliding door. Alternatively, wicket door can be built into the roller shutter or sliding door.

All roller shutters or sliding doors that are not provided with wicket doors and located across means of escape are required to be kept in the open position when premise is occupied.

Wicket door

- (ii) Wicket door shall be permitted to be incorporated within a roller shutter or sliding door. The wicket door shall be of the swing type having a minimum head height of 2.1m and a clear width of not less than the required door clear width. The wicket door shall comply with all the requirements of exit access door, and be clearly marked and readily visible so that the occupants can readily see where the door is. It should be fitted only with simple fastenings that can be manually operated for ease of escape, or

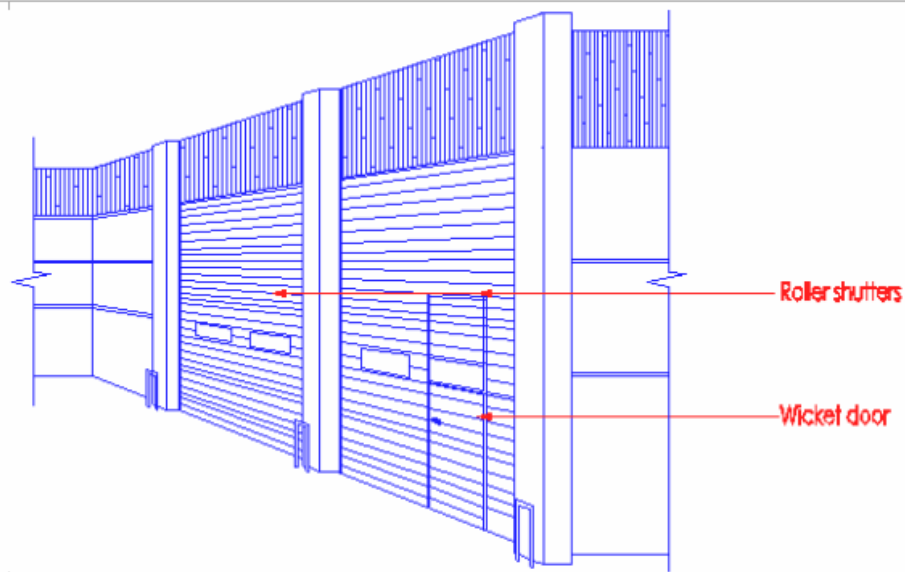

Diagram 2.3.9 (h) (ii)

Wicket doors are permitted to be incorporated within a roller shutter or sliding door. The wicket doors shall be able to perform the same functions as side hinged door and shall be able to be swung open in the direction of exit travel when used. Wicket doors shall comply with all requirements of exit access door, clearly marked and readily visible.

Sliding door with swing-out feature

- (iii) A sliding door which can be swung open as well, shall swing in the direction of escape travel when a certain horizontal force is applied to the door. When the sliding door is converted to a swing door, it shall comply with all the requirements of an exit access door. The manual perpendicular force required to open the door shall not be more than 70N when applied at the door handle or catch/knob located at the opening edge of the door under still air conditions. A readily visible sign with the letterings "IN EMERGENCY, PUSH TO OPEN" shall be affixed onto the door, or

(No illustration)

Power operated sliding doors/ roller shutter

- (iv) Power operated automatic sliding doors/ roller shutters, shall be linked to the building fire alarm system. The sliding door/ roller shutter shall automatically open to the required width/height (of door opening) upon the activation of the fire alarm. The automatic sliding door/ roller shutter shall also comply with the following:

Fail safe type

- The automatic sliding doors/ roller shutters shall be of the fail safe type. Should there be any fault in the electrical or sensor device, or any power failure (either mains or battery powered), these doors shall automatically open and remain in an open position until power is restored.

Manual override

- A manual override mechanism (a device to trigger the immediate opening of sliding doors/ roller shutters) shall be provided. The doors shall open and remain open upon activation of this device. This device shall be housed in a break glass box located beside the sliding doors or roller shutters and fixed at a height of 1.4m above the finished floor level. It shall be easily accessible, conspicuous and be free from obstructions. A readily discernible sign with the lettering "EMERGENCY DOOR RELEASE" shall be permanently pasted beside the switch. The letterings shall be of at least 15mm in height.

(No illustration)

- 2.3.9 (i) Any exit door or exit access door serving spaces of assembly/mass occupation, such as auditorium, concert hall, theatre, assembly hall, exhibition hall, cinema, etc which has to be kept shut and fastened while the building or part of the building is occupied shall be fitted with 'panic bolt' and appropriately marked 'Push Bar To Open' in letters not less than 1000mm high to enable the door to be quickly opened when a pressure on the bar is applied in the direction of travel.

(No illustration)

- (j) Locking of staircase and smoke stop/fire lift lobby doors

One way locking device is allowed to be provided to doors of exit staircase, smoke stop/fire lift lobby in the following situations, provided only one-way locking device is used, eg panic bolt or thumb turn locking device :

- (i) exit door between staircase shaft and occupancy area; and
- (ii) exit access door between smoke/fire fighting lobby and occupancy area; and
- (iii) exit door between staircase shaft and smoke stop lobby; and
- (iv) exit door between staircase shaft and circulation area; and
- (v) exit access door between smoke stop/fire fighting lobby and circulation area.

For selected floors under subclause 2.3.9(l), the doors of the fire fighting/exit staircase and smoke stop/fire fighting lobby shall not be fitted with any locking device to allow for re-entry from the staircase to the interior of the building.

Exemption of power operated sliding doors/roller shutters and swing doors of unit owners or tenants from the need to link to the building fire alarm system

- (i) We have received feedback from members of the public and building owners that powered sliding doors, roller shutters and swing doors that belong to unit owners or tenants should not be linked to the building fire alarm system. The main concern is that in the event of false alarm, such doors would be activated to open. Thus posing security risk to the unit owners or tenants.*
- (ii) With immediate effect, powered sliding doors, roller shutters and swing doors that belong to the unit owners or tenants are not required to be linked to the building fire alarm system, provided they are design as fail safe type, installed with manual over-ride, and do not form part of the building's fire protection system, for example, smoke control system.*

2.3.9 (k)

Where access-control is provided to exit door using smart card locking device, magnetic bar and electro-mechanical locking device :-

- (i) The activation of the building fire alarm or sprinkler system shall automatically unlock the door. It shall remain unlocked until the building fire alarm system system has been manually reset; and

- (ii) The door shall be arranged to unlock from a manual release device located within the occupancy space, 1200mm above the floor and within 1.5m of the exit door jamb. The manual override device shall be readily accessible and clearly identified by a sign that reads "Emergency Door Release". The mechanism to unlock the door shall be fail-safe type.
- (iii) Where doors opening into passenger lift lobby are to be provided with access-control and would be locked after normal operation hours, the lobby shall be designed to have direct access to at least one exit staircase to prevent any occupant from being trapped in the lobby when the lifts are recalled at 1st storey or other designated floor during fire emergency or building's power failure. Alternatively, a two-way communication system shall be available inside the lift lobby for use by trapped occupants to call for help. The two-way communication system shall be linked to the fire command centre and/or building control room which shall be manned 24 hours.

(Footnote: See Attached circular dated 8th April 2003)

We have received feedback from the members of the public and building owners that powered sliding doors, roller shutters and swing doors that belong to unit owners or tenants should not be linked to the building fire alarm system. The main concern is that in the event of false alarm, such doors would be activated to open, thus posing security risk to the unit owners and tenants.

With immediate effect, powered sliding doors, roller shutters and swing doors that belong to unit owners or tenants are not required to be linked to the building fire alarm system, provided that they are designed fail safe type, installed with manual over-ride, and do not form part of the building's protection system, for example, smoke control systems.

(I) Staircase re-entry

- (i) Every exit staircase enclosure serving more than 7 storeys of non-residential building, excluding buildings of detention and correctional occupancies, shall allow re-entry from the staircase enclosure to the interior of the building. There shall be at least 1 level where it is possible to re-enter into the interior of the building from the staircase enclosure.

- (ii) There shall be not more than 6 intervening floors between floors where it is possible to leave the staircase enclosure, either re-enter into the building or exit to the exterior space at grade level or to another building. This would ensure that an occupant need not travel more than 3 floors up or down the staircase to re-enter into or exit from the building.

Example of a 9-storey building requiring 1 re-entry point to the exit staircase

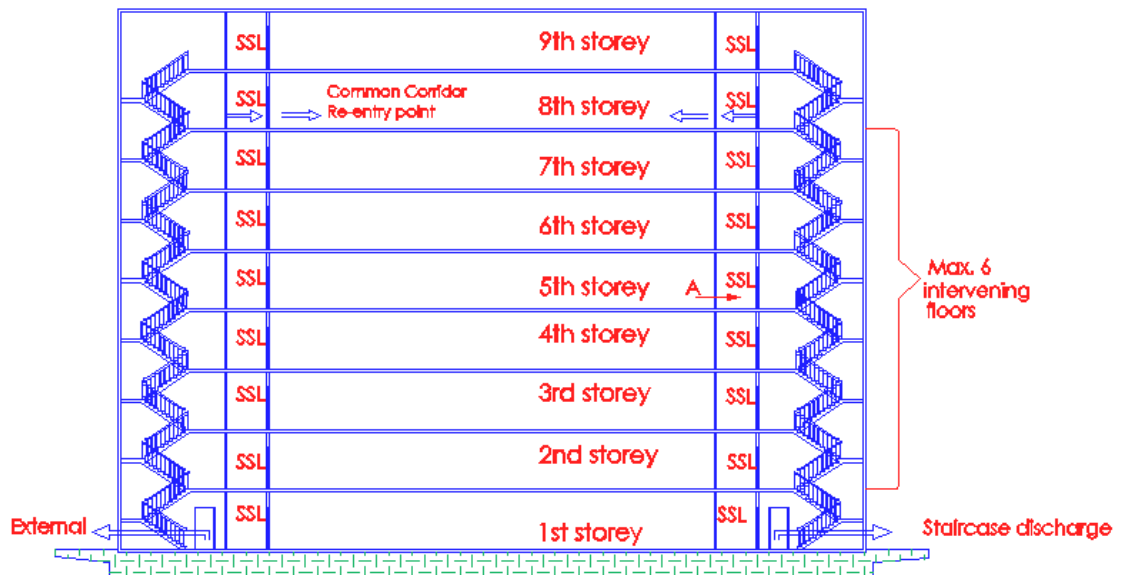

Diagram 2.3.9(I)-2

Occupant A needs not travel more than 3 floors up to gain re-entry at 8th storey.

The main purpose of re-entry door is to allow occupants to re-enter the building space to look for an alternative exit via a common corridor. This need would arise if the evacuation descend in the staircase is being held-up because of a locked exit door at 1st storey or other reasons.

Example of a 10-storey building requiring 1 re-entry point to the exit staircase

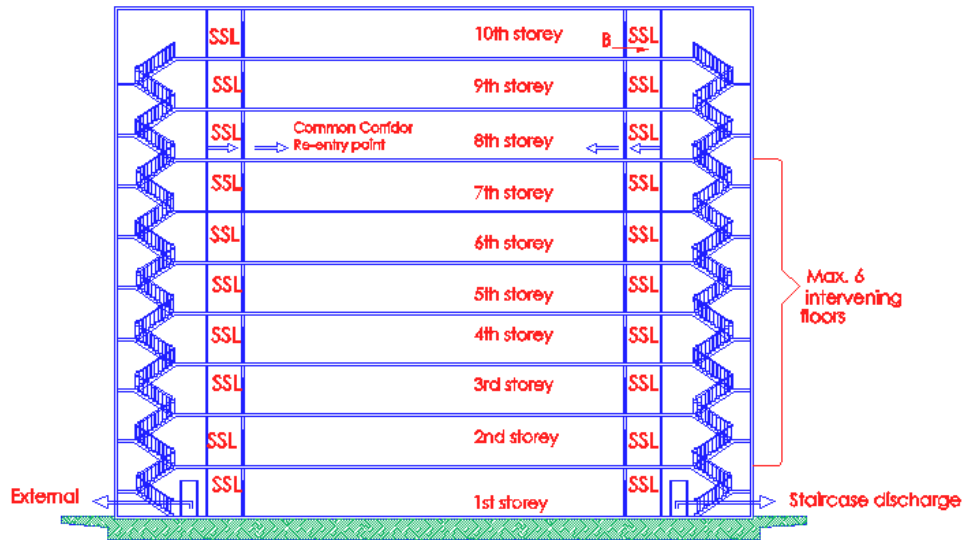

Diagram 2.3.9(I)-3

Occupant B needs to travel 2 floors down to gain re-entry at 8th storey

Example of a 11-storey building requiring 1 re-entry point to the exit staircase



Diagram 2.3.9(I)-4

Occupant B needs to travel not more than 3 floors down to gain re-entry at 8th storey

Example of a 12-storey building requiring more than 1 re-entry point to the exit staircase

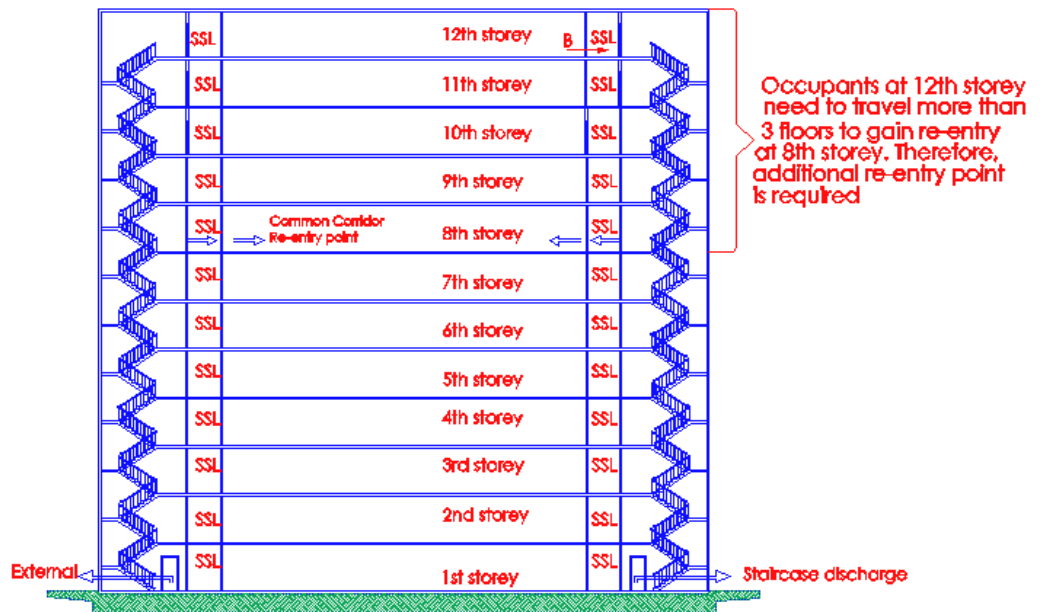

Diagram 2.3.9(I)-5

Occupant B needs to travel more than 3 floors down to gain re-entry at 8th storey. An additional re-entry point to each exit staircase should be provided.

- (iii) Where re-entry is provided from the staircase enclosure, it shall enter into a common corridor that is connected directly to at least one other exit staircase
- (iv) Staircase doors permitting re-entry into the building, shall be identified with a signage "Re-entry door" of min. 50mm lettering height on the staircase side of the staircase door.

Staircase Re-entry Floor

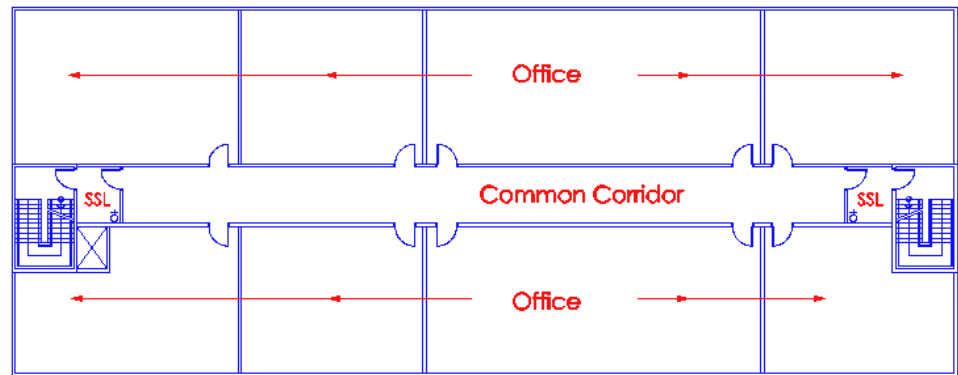

Diagram 2.3.9(I)-1

Typical Office Floor plan – Staircase doors that provide re- entry to the floor space shall be linked to at least one other exit staircase via common corridor.

2.6 OFFICE AND SHOP OCCUPANCY

2.6.1 Number of exit staircases or exits per storey

In an office, shop, factory and warehouse building, at least two independent exit staircases or other exits shall be provided in compliance with the requirements of Cl. 2.2.11, except that one exit staircase is permitted to serve the upper storeys, if the building is of non-combustible construction and not exceeding four storeys, subject to:

- (a) The maximum travel distance on any storey complying with column (ii) of Table 2.2A; and
- (b) Exit staircase conforming to the requirements of Cl.2.3.3 ; and
- (c) The gross floor area of each upper storey of shop, factory and warehouse building not exceeding 200m², including service ducts, lift shafts, toilets, staircase etc; and
- (d) The habitable height of the shop, factory or warehouse building not exceeding 15m; and

$AB \leq 15\text{m}$ (25m if sprinklered)

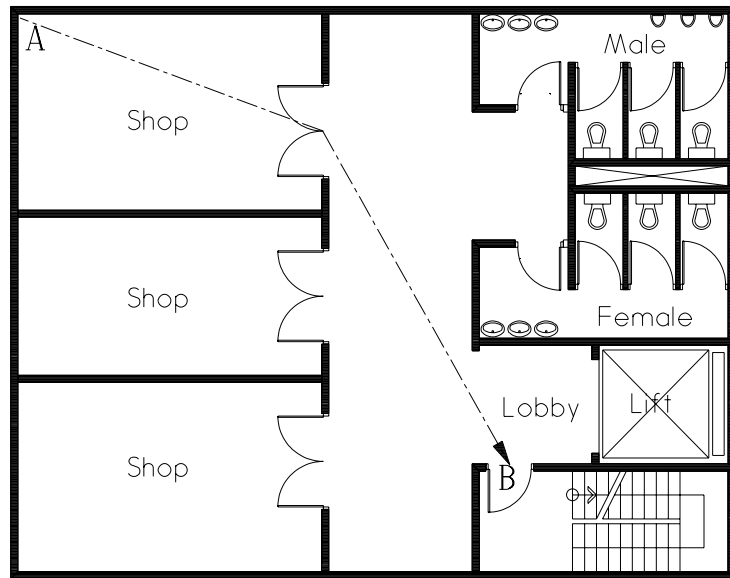

Diagram 2.6.1-1

- Occupant Load ≤ 50 persons
- One-way travel distance AB, $\leq 15\text{m}$ or 25m (if sprinkler protected)
- Floor area $\leq 185\text{m}^2$ (not applicable to office)
- Gross floor area includes service ducts, lift shafts, toilets and staircase.
- Building shall not exceed 4 storeys or habitable height of 15m whichever is lower.

Office – Max. 4 storey

AC, BC or DE \leq 15m (30m if sprinklered)

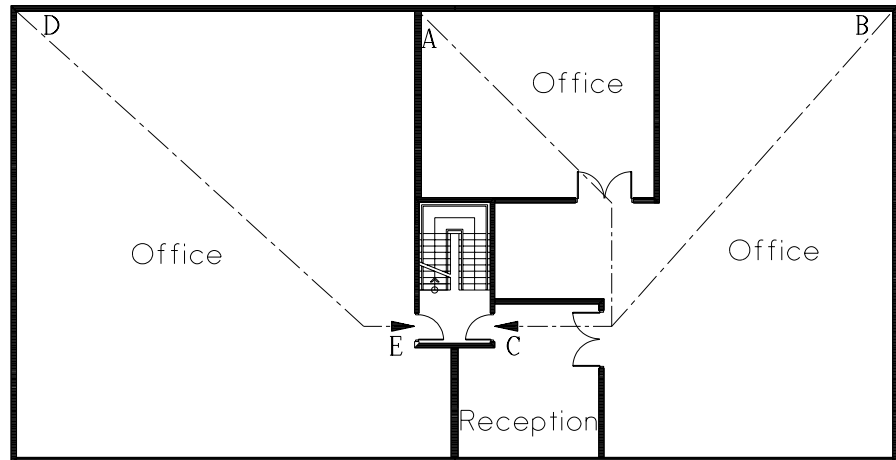

Diagram 2.6.1 – 2

- One-way travel distance AC, BC , \leq 15m or 30m (if sprinkler protected)
 - DE shall be treated as one-way direct distance as the floor space is an open floor plan. The direct distance for DE shall be $\frac{2}{3} \times 15\text{m}$ or $\frac{2}{3} \times 30\text{m}$, if sprinklered.
- (e) Access to the building for fire fighting appliances being provided for in compliance with the requirements in Chapter 4.

2.7 HOTELS

2.7.1 Internal corridor to hotel

Hotel bedrooms with access through an internal corridor shall comply with the requirements as follows:

(a) Bedrooms

Hotel bedrooms shall be separated from the internal corridor by a wall having fire resistance of at least 1 hour, and

(b) Doors opening into internal corridors shall have fire resistance of at least half an hour and fitted with automatic self-closing device to comply with the requirements of Cl.3.9.2, and

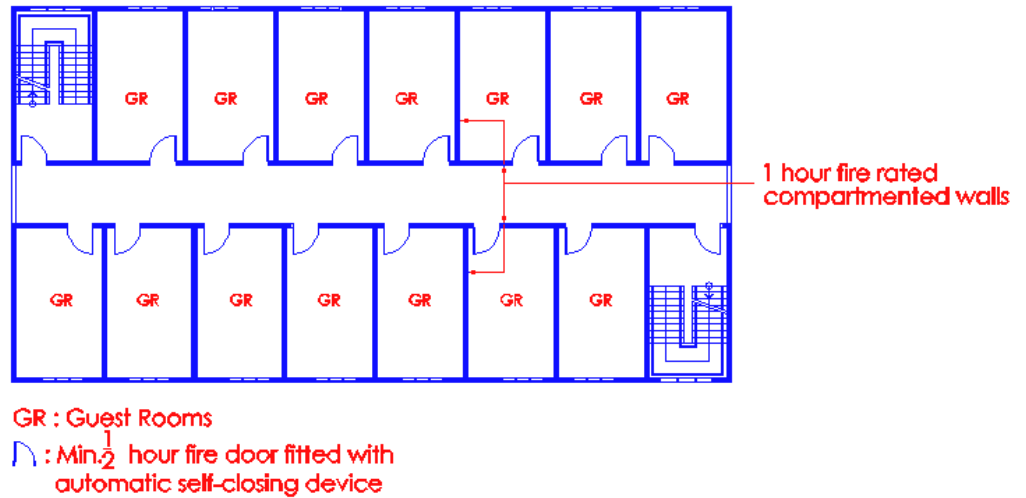

Diagram 2.7.1(a) &(b)

Each guestroom is treated as a fire compartment. Walls facing the corridor and between guestrooms may be constructed of fire rated materials other than masonry. They shall be of full height carried right-up to the underside of the soffit of the floor slab above or to an imperforate fire rated ceiling or to the roof coverings.

- (c) Internal corridors shall be naturally ventilated with fixed openings in an external wall, such ventilation openings being not less than 15 per cent of the floor area of the internal corridor, and internal corridors which cannot be naturally ventilated shall be pressurised to comply with the requirements in chapter 7.

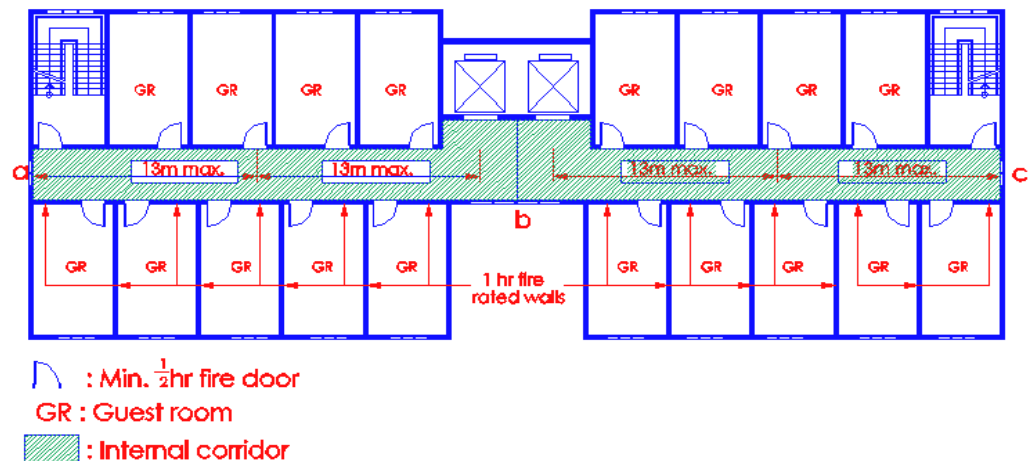

Diagram 2.7.1(c)

For natural ventilation to the internal corridor, the total fixed openings (a + b + c) shall not be less than 15% of the area of the internal corridor. Alternatively, internal corridor can be provided with mechanical ventilation and pressurised to comply with the requirements in Chapter 7. No part of the corridor shall be at a distance of more than 13m from any ventilation openings.

- (d) Other rooms or spaces which open into or form part of the bedroom corridor which may prejudice the means of escape provision shall be required to be compartmented to the same extent as the bedrooms, at the discretion of the Relevant Authority.

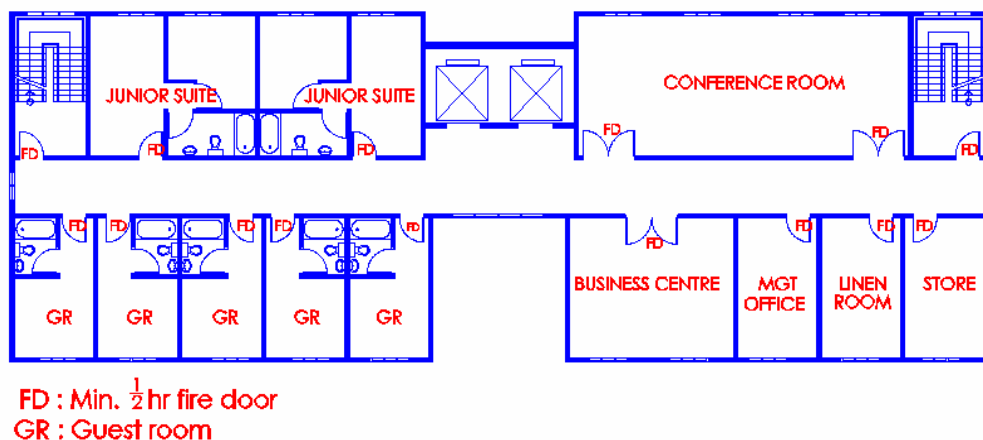

Diagram 2.7.1(d)

Other rooms or spaces include linen room, which required to be fire compartmented with 1-hour fire rated enclosure and $\frac{1}{2}$ hour fire door respectively. Lounge area, business centre etc. should be treated as guestroom. Therefore, compartmentation is required.

2.7.2 External corridor

Hotel bedrooms with access through an external corridor shall comply with the requirements as follows:

- (a) Hotel bedrooms shall be separated from the external corridor by a wall having fire resistance of at least 1 hour, except that ventilation openings of non-combustible construction may be fixed at or above a level of 1.1m, measured from the finished floor level of the external corridor to the sill height of the opening, and
- (b) Doors opening into the external corridor shall not be required to have fire resistance rating, and

- (c) External corridors shall conform to the requirements of external exit passageway for minimum width, changes in floor level, roof protection and enclosure on the open side.

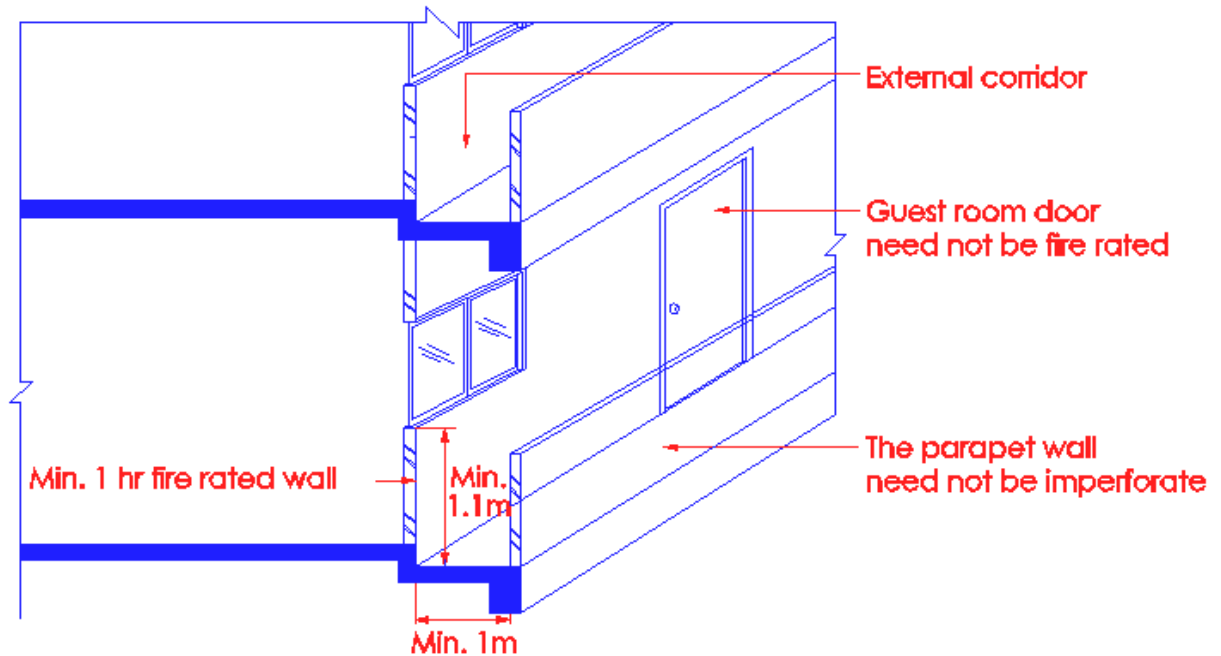

Diagram 2.7.2(a), (b) & (c)

The depth of the roof protection over the corridor shall not exceed 3m. The open side of the corridor shall not be installed with glazing, blinds, etc. The external corridor refers to corridor which opens to the external and not to atrium.

2.7.3 Number of exit doors from hotel bedrooms

- (a) One exit door only shall be required from the hotel bedroom or suite provided that the distance measured from the most remote point in the bedroom or suite to the door shall not exceed 15m, and
- (b) Where the distance measured from the most remote point in the hotel bedroom or suite to the exit door exceeds 15m, there shall be at least two exit doors located remote from each other in accordance with cl.1.2.60, and

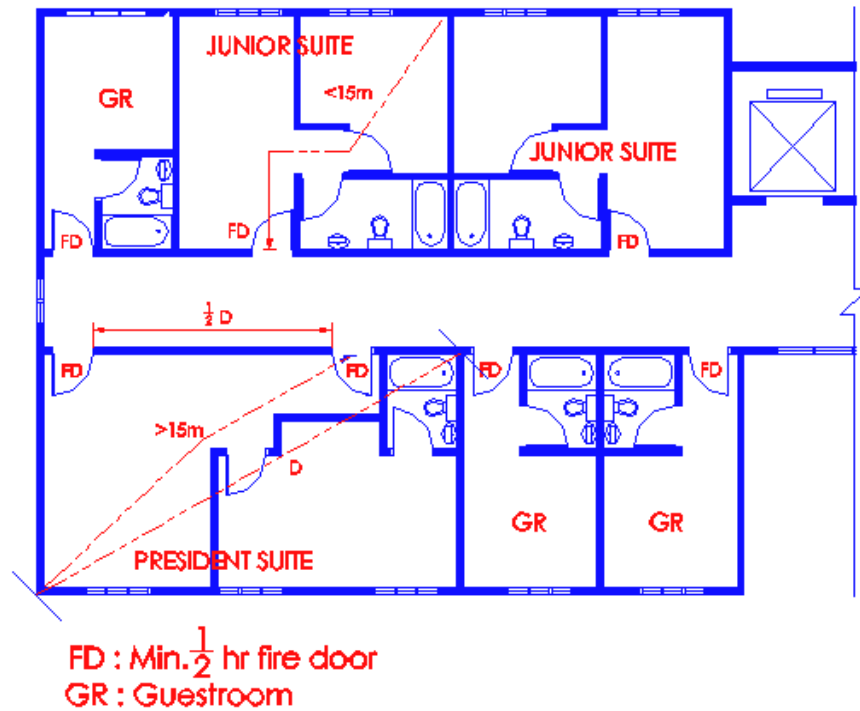

Diagram 2.7.3(a) & (b)

- (c) In the case of hotel bedrooms in a building fitted throughout with an automatic sprinkler system which complies with the requirements in Chapter 6, the distance measured from the most remote point in the bedroom or suite to the door shall not exceed 20m, for bedrooms with provision for one door.

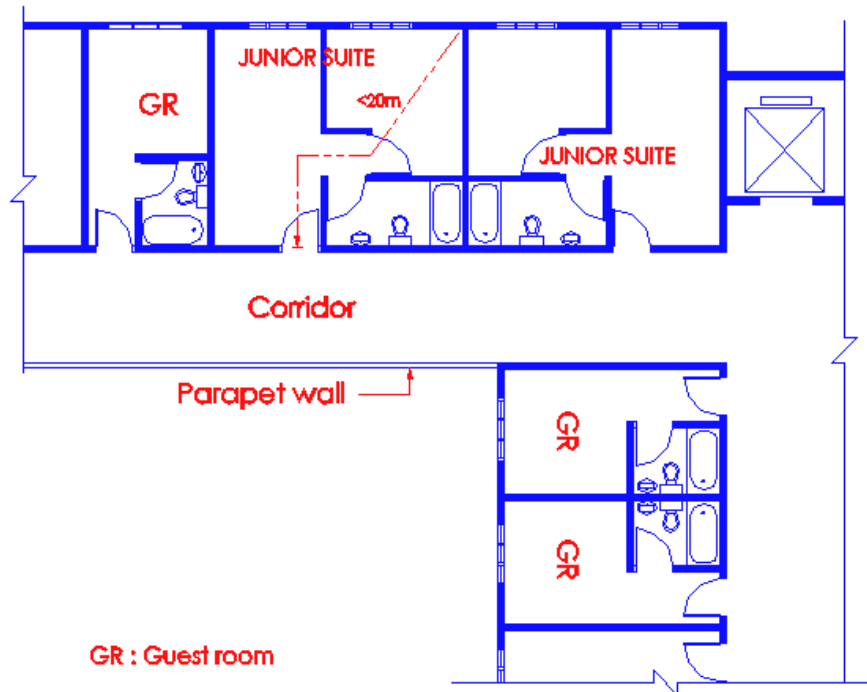

Diagram 2.7.3(c)

In the above diagram, the most remote point in the bedroom or suite measured to the entrance door shall not exceed 20m if sprinklered protected. If the above mentioned distance exceeds 20m, the room shall be provided with minimum 2 exit doors.

2.7.4 Measurement of travel distance

- (a) The travel distance shall be measured from the exit door of a hotel bedroom or suite to the exit door of an exit staircase, exit passageway or exterior open space, and
- (b) If only one way escape is provided along the corridor, the travel distance shall be measured from the most remote exit door of the bedroom, and if two way escape is provided, the travel distance shall be measured from each of the exit doors of the bedroom.

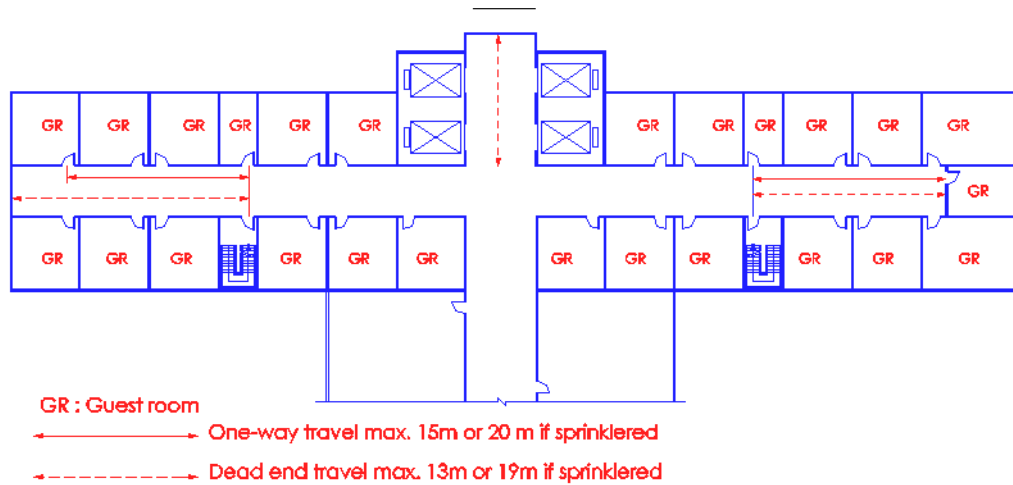

Diagram 2.7.4(a) & (b)

For dead-end definition please refer to Volume 1, clause 1.2.17

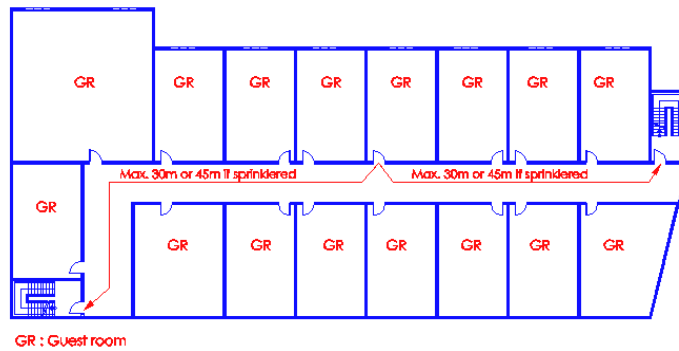

Diagram 2.7.4(b) - 1

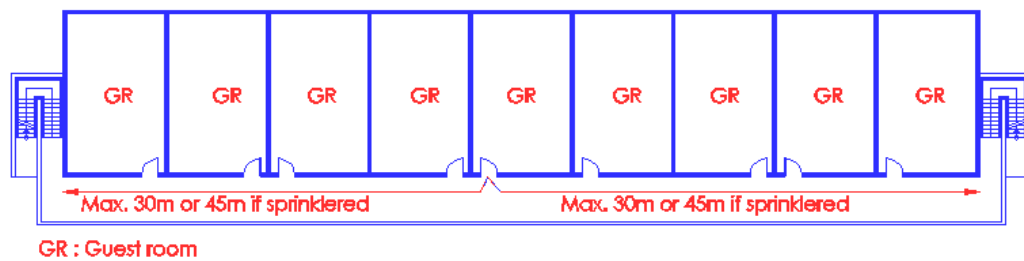

Diagram 2.7.4(b) - 2

For diagrams 2.7.4(b) - 1 & 2, it should be noted that the same limitations under clause 2.7.1 & 2.7.2 shall apply to internal and external corridors.

2.7.5 Spacing of smoke barrier

- (a) Internal corridors which are not naturally ventilated shall be subdivided by smoke barriers into the following lengths:

Building protected by sprinkler system ..45m
Building not protected by sprinkler system .. 30m

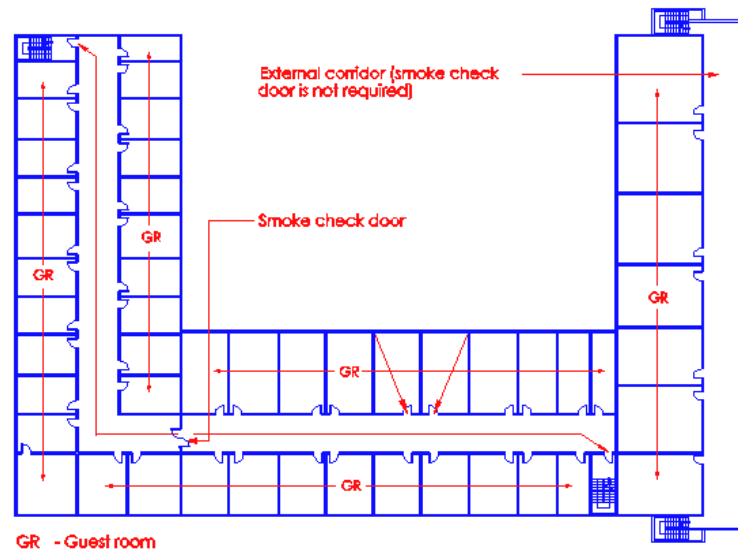

Drawing 2.7.5(a)

- (b) The smoke barriers shall consist of non-combustible partitions containing smoke check doors. The smoke barriers, including the enclosing walls to the corridor, shall be constructed to full height, carried right up to form a close joint with the soffit of the floor slab above, or an imperforate non-combustible ceiling or the roof coverings;
- (c) The smoke barriers shall be sited at suitable locations across the corridor to create multiple sections, with each having free and direct access to an exit or exit staircase, exit passageway or exit ramp.

2.7.5 (d) Vision panel

Smoke check doors excluding glass doors, shall be provided with clear glass vision panels having at least 25% of the surface area of each door leaf.

- (e) Smoke check doors shall be self-closing, swinging type and may be double-swing but shall close the opening completely with only such clearance as is reasonably necessary for proper operation. The doors shall be closely fitted around their edges and the bottom clearance gap between such doors and the floors shall not exceed 4mm;
- (f) smoke check doors shall normally be in the closed position. However, they may be left open if they are arranged to close automatically by an approved electro-magnetic or electro-mechanical device which can be activated by the presence of smoke and/or the building fire alarm system.

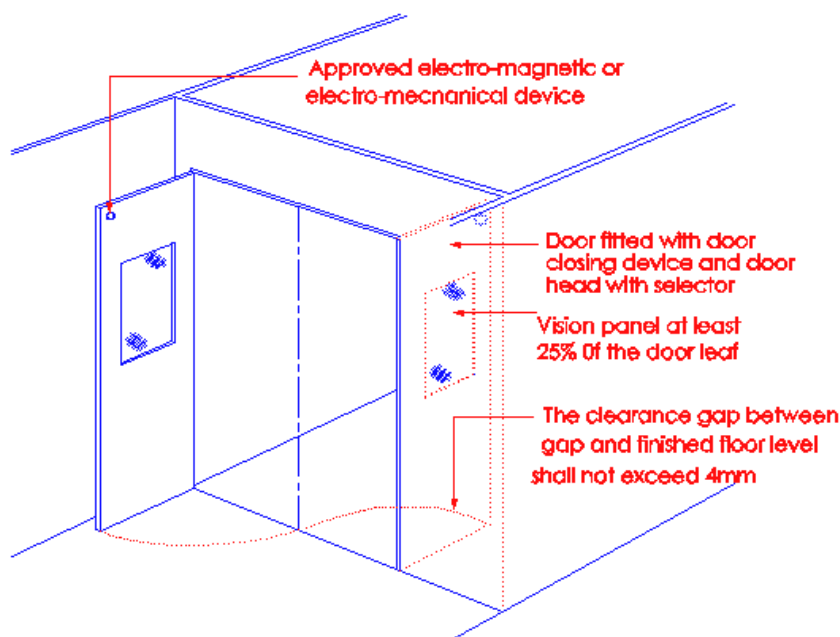

Diagram 2.7.5(d), (e) & (f) -1

The above requirement applies to internal corridors in hotel floors, which are not naturally ventilated. The smoke barriers shall consist of non-combustible partitions containing smoke check doors. The smoke barriers, including the enclosing walls to the corridor, shall be constructed of full height, carried right up to form a close joint with the soffit of the floor slab above, or an imperforate non-combustible ceiling or the roof coverings.

With long internal corridors being subdivided by smoke barriers and smoke check doors into multiple sections, there is no need to provide separate pressurisation system to each of the sub-divided sections.

The smoke barriers shall be situated at suitable locations across the corridor to create multiple sections, with each having free and direct access to an exit or exit staircase, exit passageway or exit ramps.

Smoke check door if it is not a glass doors, shall be provided with a clear glass panels having at least 25% of the surface area of the door leaf.

Smoke check doors shall be self-closing, the swinging type and may be double swinging but shall close the opening completely. The doors shall be closely fitted around their edge and the bottom clearance gap between door and finished floor level shall not exceed 4mm. The door is not required to have fire resistance rating.

Smoke check doors shall normally be in the closed position. However, they may be left open if they are arranged to close automatically by an approved electro-magnetic or electro-mechanical device which can be activated by the presence of smoke and/or the building fire alarm system.

2.8 ASSEMBLY OCCUPANCY

2.8.1 General

Assembly Occupancy include all buildings or portions of buildings used for gathering together more than 50 persons for such purpose as deliberation, worship, entertainment, eating, drinking, amusement or awaiting transportation.

Assembly Occupancies include but are not limited to :

Theatres, Cinemas, Assembly Halls, Auditoriums, Exhibition Halls, Museums, Skating Rinks, Gymnasiums, Bowling Establishments, Pool Rooms, Armouries, Mortuary Chapels, Libraries, Restaurants, Nightclubs, Discotheques, Churches, Dance Halls, Club Rooms, Passenger Stations and Terminals of Public Transportation Facilities, Courtrooms, Conference Rooms and Drinking Establishments.

(No illustration)

Not all buildings or portions of buildings used for assembly occupancy of more than 50 persons are considered as public building. Clause 1.2.49 of the Fire Code defines "public building" as those buildings or part thereof used or constructed or adapted to be used as a shop, office, hospital or place of public resort, not being a church, chapel, mosque, temple or other place where public worship is or religious ceremonies are performed. See Volume 1, Definitions on clause 1.2.49 for further explanation on "public building".

Assembly occupancy could be found in other purpose groups other than places of public resort, for example auditorium in office building, lecture theatre in school/institution, etc.

2.8.2 Number and width of exit facilities

Number and minimum width of exits for assembly occupancies shall comply with the provisions tabulated as follows :

No of Occupants	Min No of Doors	Min.Width of Corridors
50 - 200	2	1000 mm
201 - 500	2	1250 mm
501 - 1000	3	1250 mm
exceeding 1000	4	1250 mm

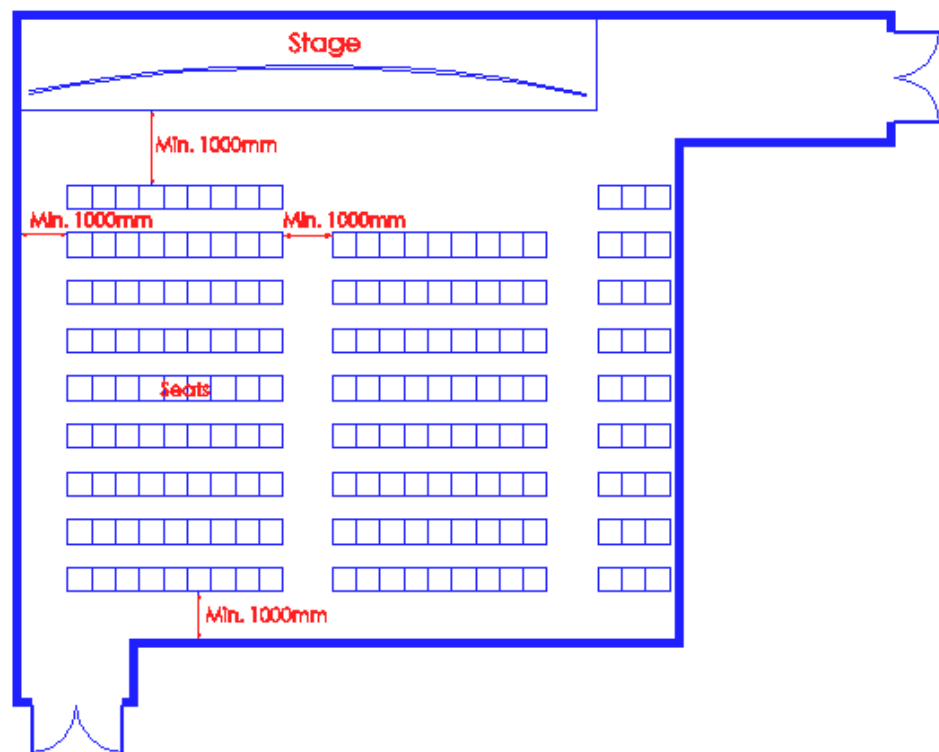

Diagram 2.8.2

The total number of occupant load of the above auditorium is more than 50 persons, but not exceeding 200 persons. The clear width of each exit door shall be sufficient to receive at least half the occupant of the floor space. The clear width of the aisles or gangways shall not be less than 1000mm. The exit doors shall be sited remote from each other to comply with cl.1.2.60.

2.8.3 Assembly Occupancy with Fixed Seating: (Theatres, Cinemas, Auditoriums, Concert Halls etc)

Aisles and Gangways

- (a) clear aisles or gangways of not less than the minimum width of corridors shall be provided around the auditorium, stalls and balconies leading to doors or exit doors, and
- (b) aisles or gangways shall be provided with intersecting rows of seating and the number of seats in a row shall be in accordance with the provisions tabulated as follows:

Table 2.8.3(a)(ii) Number of seats in a row

Seat way width mm	Maximum No of seats in a row	
	Gangway on one side	Gangway on two sides
300 to 324	7	14
325 to 349	8	16
350 to 374	9	18
375 to 399	10	20
400 to 424	11	22
425 to 449)	24
450 to 474)	26
475 to 499)	28
500 or more)	Limited by the travel distance

The seatway shall be the minimum clear width between rows, which shall not be less than 300mm, measured as the clear horizontal distance from the back of the row ahead (including seats that tip up automatically) and the nearest projection of the row behind when the seats are in upright position. The seatway widths shall be constant throughout the length of the row. (See diagrams 2.8.3(a)(ii) - A and B).

Seat way width and number of seats in row

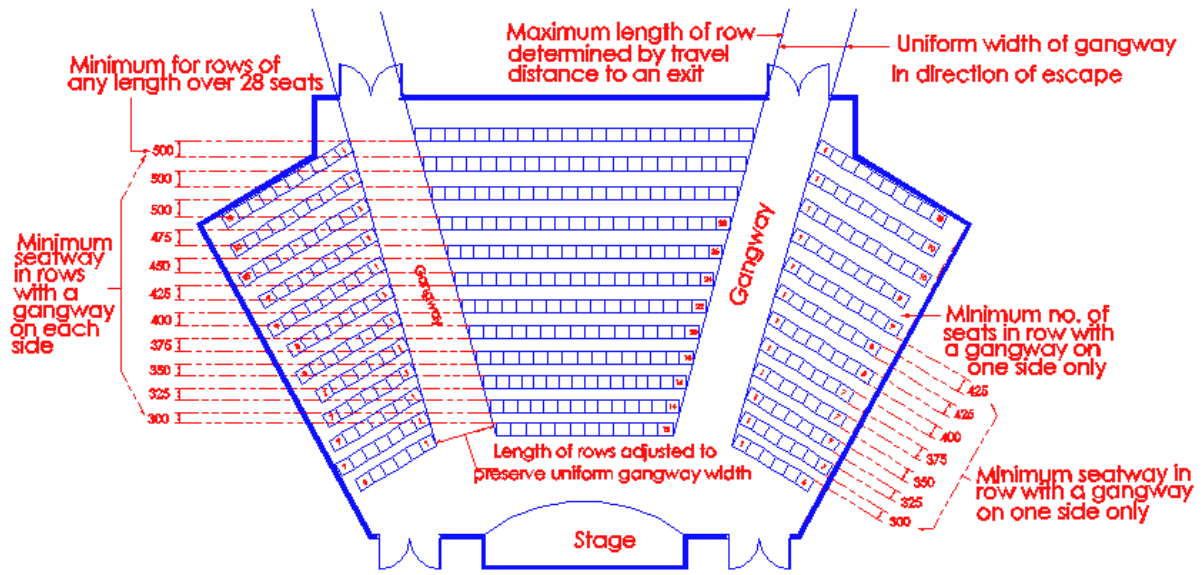

Diagram 2.8.3(a)(ii) - A

The above diagram illustrates uniform width of gangway in the direction of escape, where escape in opposite directions are available in the auditorium.

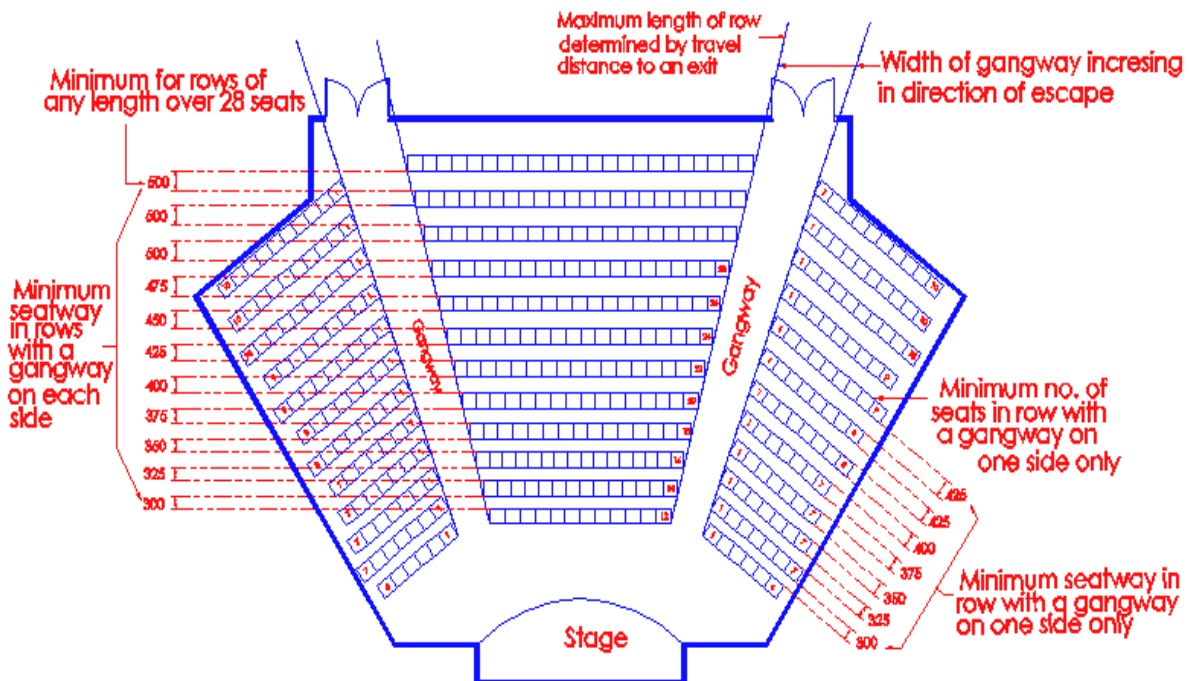

Diagram 2.8.3(a)(ii) - a

Prior consultation with SCDF (FSSD) is required if any row has more than 30 seats, as there could be concern on congestion along the gangways and at the exits.

The seating materials, in all cinemas, theatres, concert halls, auditorium, etc are required to be type tested by a recognised testing laboratory and subject to the PSB's Product Listing Scheme.

Determination of seatway width

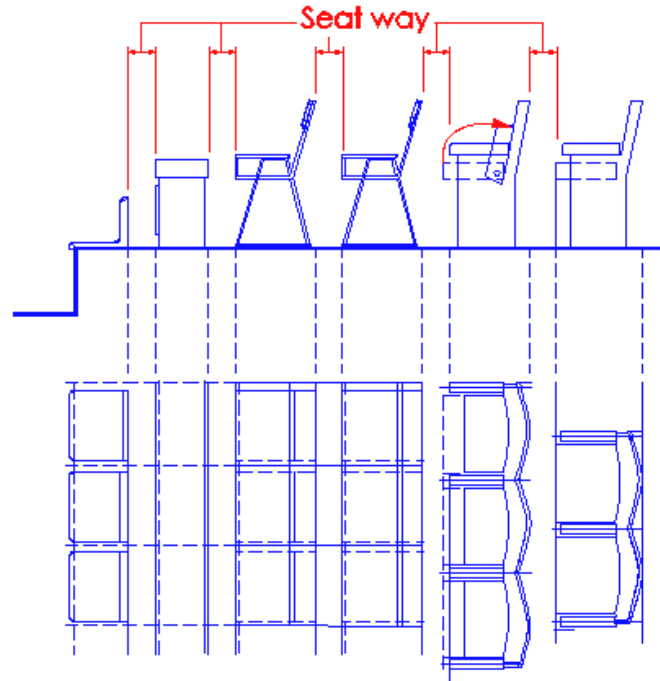

Diagram 2.8.3(a)(ii) - B

Seatway widths should be not less than the tabulated seatway width in Table 2.8.3(a)(ii) and should be constant throughout the length of the row. Traditionally, the number of seats has been limited to maximum of 14 seats per row. Currently, the Table 2.8.3(ii) has allowed greater flexibility in increasing the number of seats. One of the reasons for allowing it is that there is an increase of seatway width to facilitate easy movement towards the gangway(s), thus allowing faster evacuation of occupants.

- 2.8.3 (c) for changes of level, steps shall not be used to overcome differences in level in aisles or gangways unless the slope of such gangways exceeds 1 in 10, and

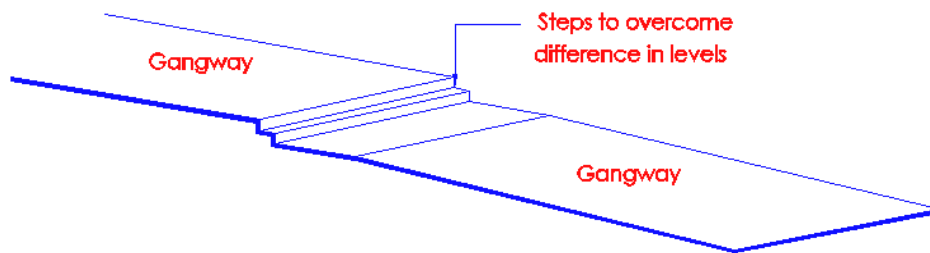

Diagram 2.8.3(c)

Steps (min. 2 numbers) may be used when gradient of slope of gangways exceeds 1 in 10. The dimensions of treads and risers shall comply with cl.2.3.3(d0(iii)).

- (d) handrails shall be provided, where steps of a pitch exceeding 30 degrees or ramps of a slope exceeding 1 in 10 are provided in aisles or gangways flanking the seating, and

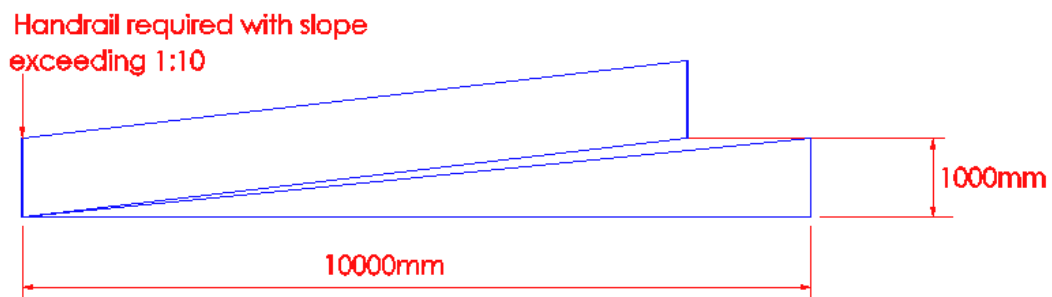

Diagram 2.8.3(d) - 1

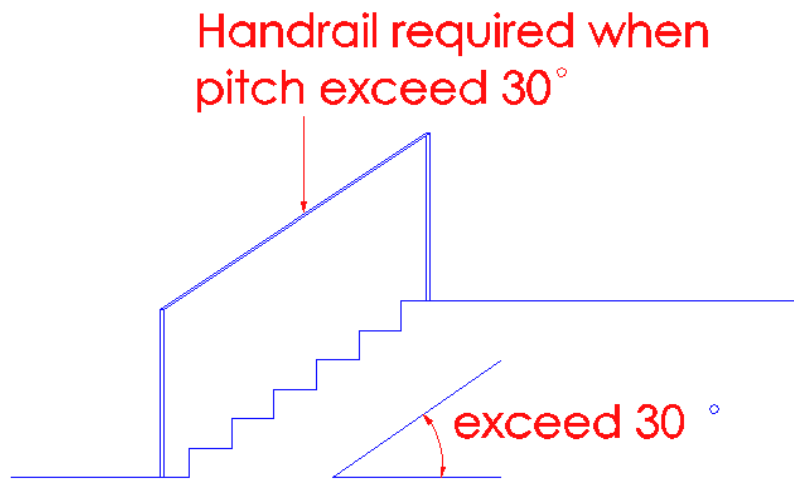

Diagram 2.8.3(d) – 2

- (e) flooring for the surface of steps and ramps forming the aisles or gangways shall be finished using non-slip materials, and

(No illustration)

Besides non-slip tiles, carpets are also commonly used in cinemas.

- 2.8.3 (f) illumination of steps shall be such that each step is clearly visible when the general lighting is switched off.

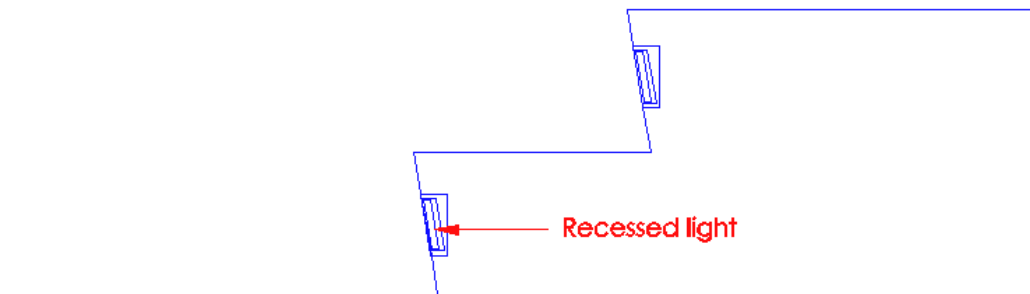

Diagram 2.8.4(f)

The rationale of illuminating the steps is intended to alert the public of the presence of steps. Such arrangement will help to prevent tripping. Where the emergency lighting of the hall or auditorium is able to provide sufficient lighting to the steps, separate emergency power supply to illuminate the steps would not be required.

2.8.4

Exits from a theatre, cinema or a concert hall

- (a) The number and capacity of exits from a theatre, cinema or concert hall shall be provided within its own compartment without having to take into account exits provided for its adjoining parts of the same building in which it is housed. Exception may be permitted where the occupancy load does not exceed 200, in which case at least half the capacity of exits must be provided within the compartment.
- (b) The exits adjacent or attached to cinema, theatre or concert hall and the like can be shared as exits with the other parts of the building, subject to the following:
 - (i) the exits are accessible from the common circulation areas; and
 - (ii) the occupancy load of the cinema, theatre, concert hall and the like does not exceed 200 persons.

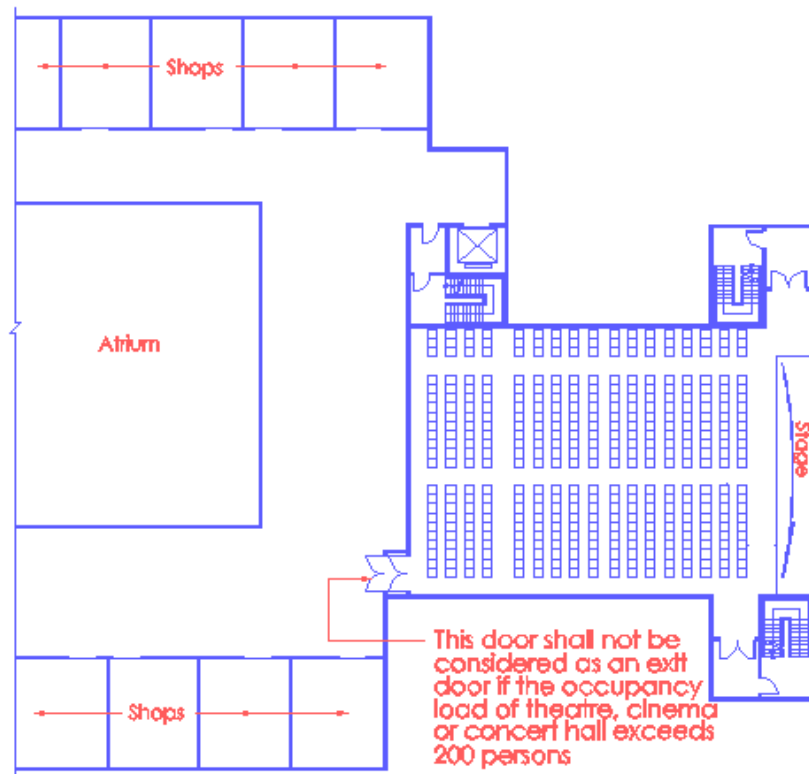

Diagram 2.8.4

A theatre, cinema or concert hall is considered a compartment by itself. It should be self sufficient in the provision of the exits for the occupants. Sharing of exit facilities with other part of the building under different occupancy is not permitted unless the occupant load of the theatre, cinema or concert hall is less than 200 persons.

- 2.8.5 Where a building or part of a building is designed as a cineplex to house multiple mini- cinemas, the means of escape to be provided may be shared by all the mini-cinemas. Each cineplex shall be treated as a single big cinema for the purpose of determining the exit requirements under sub-clause 2.8.4.

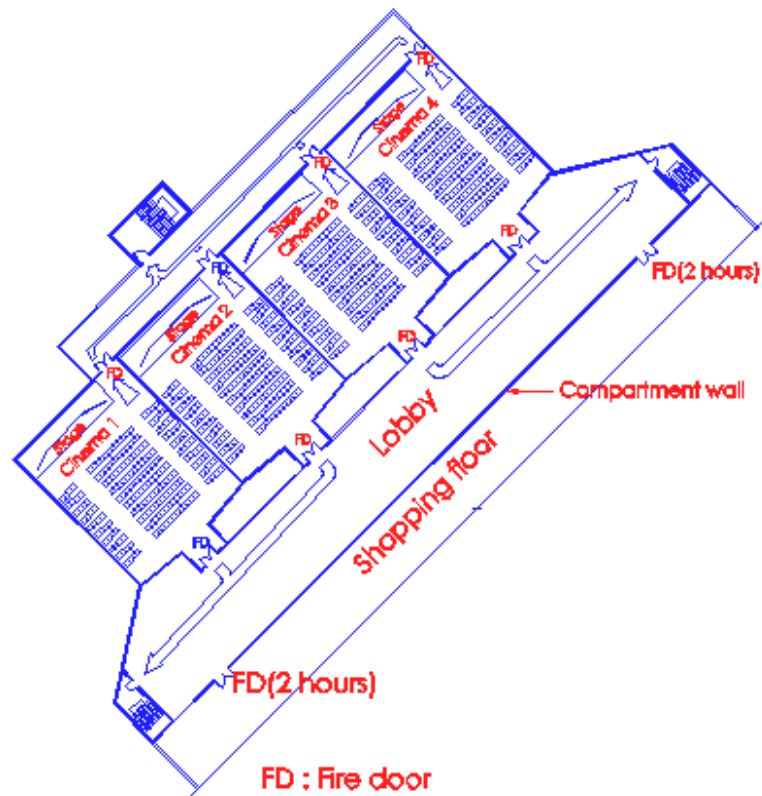

Diagram 2.8.5

The above diagram is an example of a cineplex design. Part of the building may house offices, shop or other commercial uses. Each mini-cinemas is treated as a compartment by itself. The circulation spaces with arrows indication are treated solely for escape of cinema patrons only. Ticketing kiosk, drink kiosks etc should be located outside the entrance lobby to the cinemas.

2.10 EXIT LIGHTING AND DIRECTIONAL SIGN

- 2.10.1 Exits of all buildings, except for those belonging to Purpose Group 1, shall be provided with artificial lighting facilities to the satisfaction of the requirements in Chapter 8.
(No illustration)

Exit and directional sign

- 2.10.2 In all buildings or parts of building other than those belonging to Purpose Groups I and II (residential floors only), the location of every exit on every floor shall be clearly indicated by exit sign and directional signs to comply with the requirements in Chapter 8.

(No illustration)

Details of provision of exit lighting, exit and exit directional sign will be covered in Chapter 8.