

Chapter 3

STRUCTURAL FIRE PRECAUTIONS

3.1 GENERAL

3.1.1 The purpose of this chapter is to stipulate requirements to minimise the risk of spread of fire between adjoining buildings by separation, prevent the untimely collapse of buildings in the event of fire by the provision of a stable and durable form of construction and prevent the spread of fire between specified parts of the buildings by the division of such buildings into compartments.

Structural fire precautions relate to the integrity and stability of building elements during fire for a required period of time. "Structural" does not only apply to the structural elements of buildings but other building components, e.g. doors, shafts, walls/ceiling finishes.

The objectives of structural fire precautions are :

- (a) To prevent the spread of fire between adjoining residential buildings by adequate separation;*
- (b) To prevent the untimely collapse of building, including walls and floors of each residential unit in the event of a fire*
- (c) To prevent spread of fire from one unit to another within the building envelope by compartmentalising each unit with walls, floors and doors having the requisite fire resistance rating.*

3.2.1 Compartment size - floor area & cubical extent

Any building which has -

- (a) Any storey the floor area of which exceeds that specified as relevant to a building of that height in column (2) of Table 3.2A, or
- (b) A cubic capacity which exceeds that specified as relevant in column (3) of Table 3.2A,

shall be divided into compartments by means of compartment walls and compartment floors so that -

- (i) no such compartment has any storey the floor area of which exceeds the area specified as relevant to the building in column (2) of the Table, and

- (ii) no such compartment has a cubic capacity which exceeds that specified as relevant in column (3) of the Table.

Generally, the compartment size of apartment or maisonette unit would not exceed 4000m² or a cubical extent of 15000m³ as given in Table 3.2A which is reproduced below:

TABLE 3.2A SIZE LIMITATION OF BUILDING AND COMPARTMENT

(1) Compartments	(2) Maximum Floor Area	(3) Maximum Cubical Extent
Compartment below ground level. No compartment to comprise more than one storey.	2000m ²	7500m ³
Compartments between average ground level and a height of 24m. No compartment to comprise more than 3 storeys.	4000m ²	15000m ³
Compartments above a height of 24m from average ground level. No compartment to comprise more than one storey.	2000m ²	7500m ³

However, for non-residential areas in buildings under Purpose Group II, such as communal area or car parking area irrespective of location in either upper storeys or basement, there would be a need to apply the size limitation of 4000m² or 15000m³. The above non-residential areas would be dealt with under their respective Purpose Groups VII & VIII respectively.

3.2.4. Compartmentation by Height

(a) Compartmentation

In any compartment except those mentioned under sub-clause 3.2.4(d), up to a habitable height of 24 m, no compartment shall comprise more than three storeys.

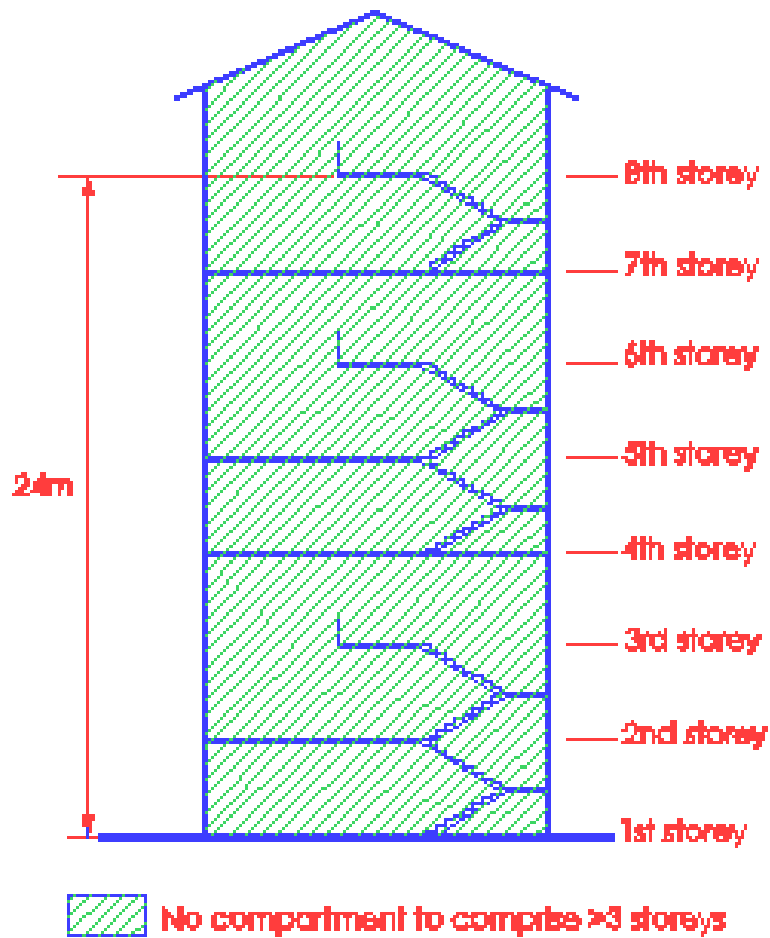

Diagram 3.2.4(a)

Where 3 storeys or levels form one compartment, the total floor area shall not exceed 4000m² and the total cubical extent shall not exceed 15000m³, subject to compliance with travel distance requirements under Chapter 2.

- (b) In any building which exceeds 24m in habitable height, compartments at storey level exceeding 24m above average ground level, may comprise two storey levels.

Acceptable

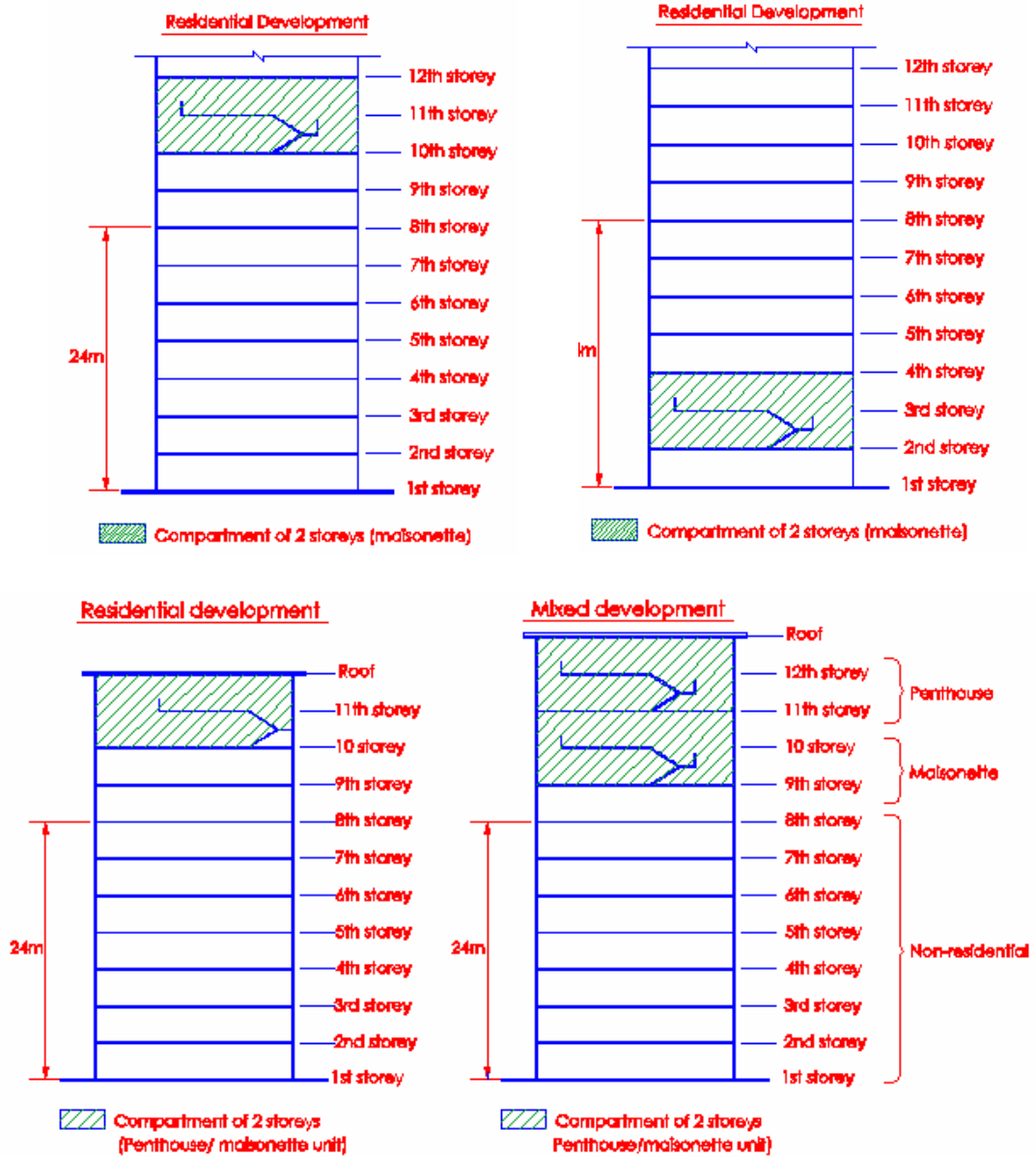

Diagram 3.2.4(b)

In any residential building which exceeds 24m in habitable height, no compartment shall comprise more than one storey per compartment from storey level exceeding 24m above average ground level. However, for residential maisonette or penthouse unit maximum two storey levels are allowed to form one compartment. This should be taken as a relaxation. There is a need to keep the fire compartment size small within 2000m² or 7500m³ above that habitable height as it would otherwise pose difficulties to fire fighting and control of fire spread should there be a fire occurrence in one of those high-rise units. In situation where there are maisonette or penthouse units located in non-residential building, fire protection/detection system applicable to the building shall be extended to cover the residential units.

3.2.5

Other cases requiring compartment walls & compartment floors

The following situations shall require compartmentation by provision of compartment walls and/or compartment floors -

(a) Purpose group II

Any wall and floor separating a residential apartment or maisonette from any other part of the same building, unless permitted (as in the case of an external wall adjoining an external corridor, for provision of window openings).

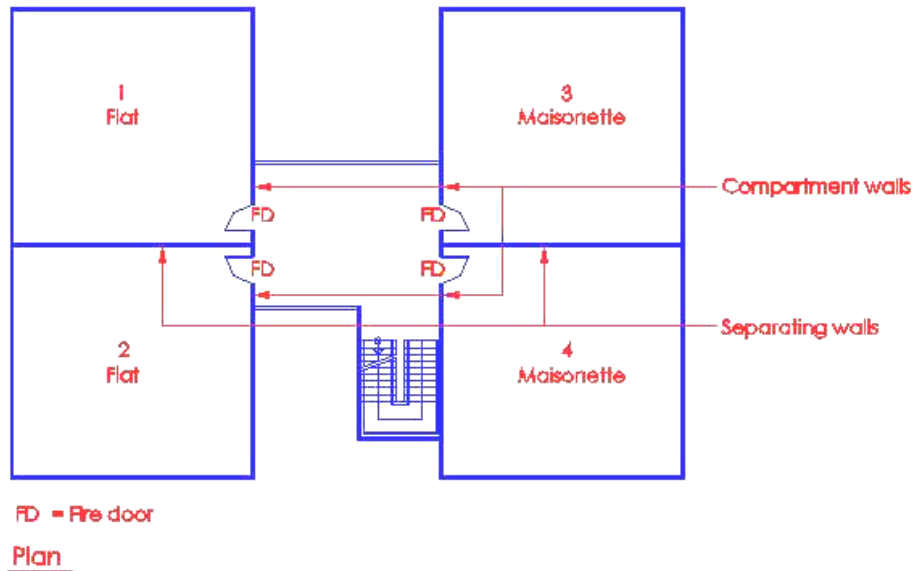

Diagram 3.2.5(a) – 1

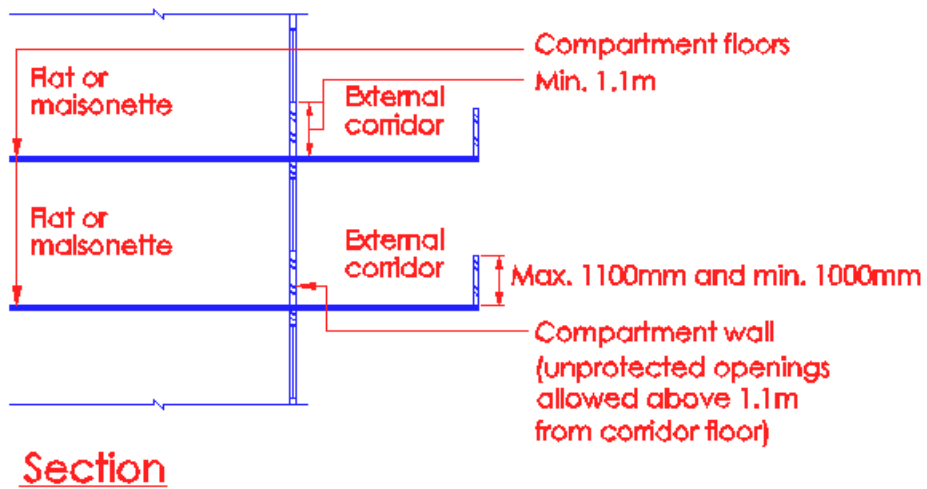

Diagram 3.2.5(a) - 2

(b) Separation of purpose groups

Any wall and floor separating part of a building from any other part of the same building which is used or intended to be used mainly for a purpose falling within a different purpose group, as identified under Table 1.2B.

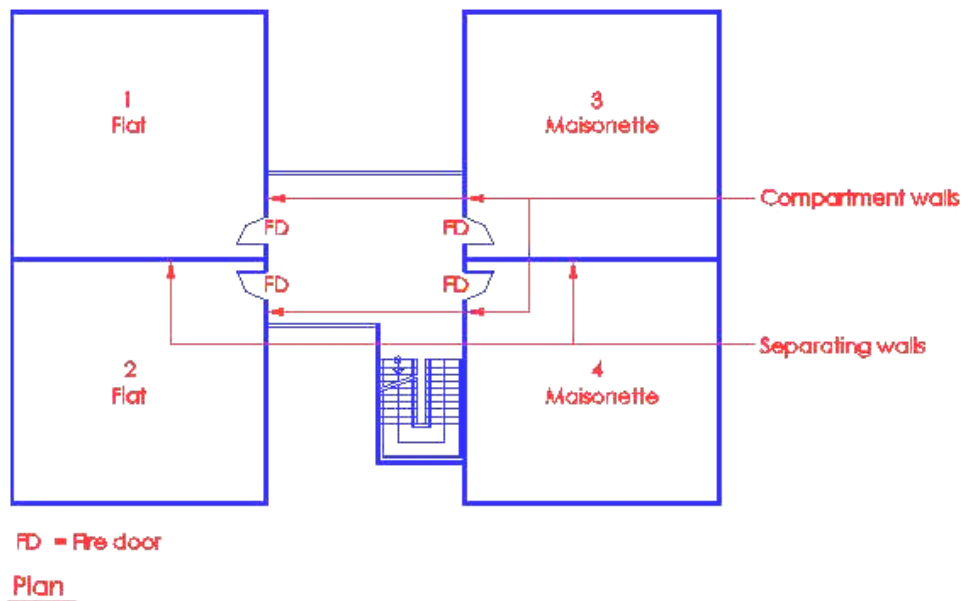

Diagram 3.2.5(b)

(c) Floor over a basement

Any floor immediately over a basement storey if such storey –

- (i) forms part of a building or compartment of purpose group II; and

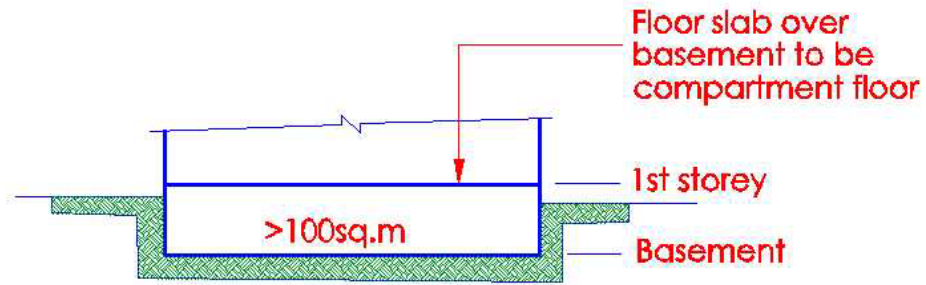

Diagram 3.2.5(c)(I)

Where the floor area of the basement exceeds 100sq.m it shall be a compartment below ground level and shall not comprise more than one storey.

- (ii) has an area exceeding 100 m².

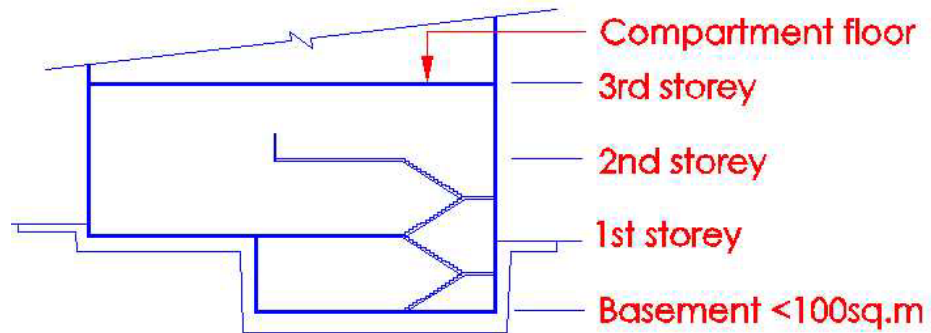

Diagram 3.2.5(c)(ii) - 1

In situation where the basement floor area is not exceeding 100sq.m, the basement and upper storeys may be allowed to be interconnected to form one compartment, subject to max. 3 storeys or levels in a single compartment. It should be noted that Cl.3.2.5(d) prohibits more than one storey below ground level to be connected to form one compartment

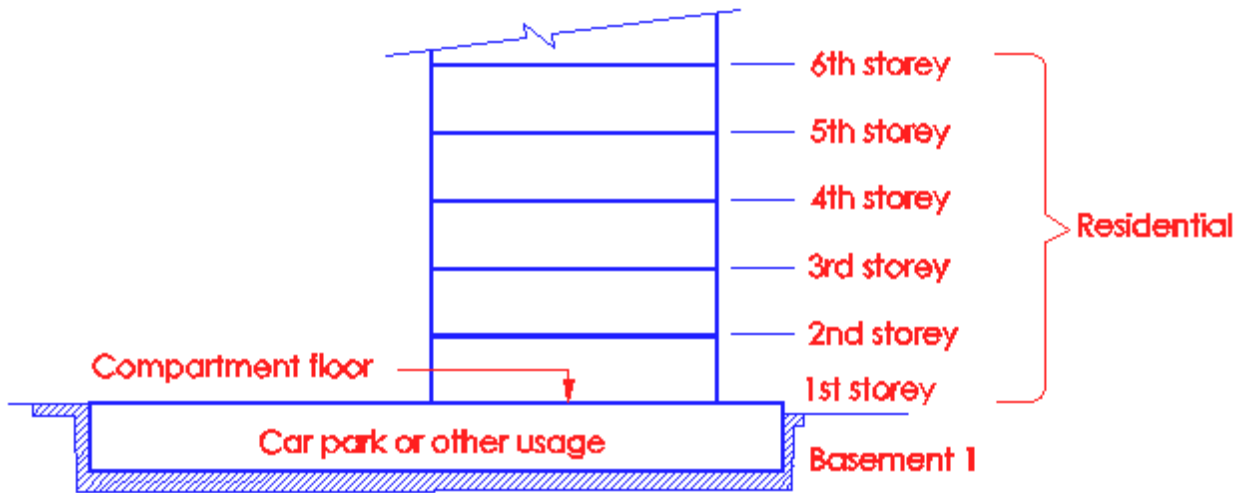

Diagram 3.2.5(c) (ii)-2

(n) Store room

For non-sprinklered buildings, if the area of the store room exceeds 10 m², it shall be compartmented from the other parts of the same building by compartment walls and floors having fire resistance of not less than 1 hour. No fire compartmentation is required for a store room which is housed within a sprinklered protected building.

(No illustration)

The above clause does not apply to store room inside apartment/maisonette units.

3.3 FIRE RESISTANCE OF ELEMENTS OF STRUCTURE

3.3.1 Minimum period of fire resistance

Subject to any expressed provision to the contrary, any element of structure shall be constructed of non-combustible materials and to have fire resistance for not less than the relevant period specified in Table 3.3A having regard to the purpose group of the building of which it forms a part and the dimensions specified in that Table, provided that –

Any element of structure shall be so constructed as to have fire resistance for not less than the relevant period specified in Table 3.3A.

“Notes to Part I”, below the Table 3.3A, summarises how the Table is applied in determining the required period of fire resistance for a building under Purpose Group II. The ‘lines’ mentioned refers to the categories or subgroups of buildings under the same Purpose Group as shown below:

**PART I
BUILDINGS OTHER THAN SINGLE STOREY BUILDINGS**

Purpose Group (1)	Maximum dimensions			Minimum period of fire resistance (in hours) for elements of structure (*) forming part of-	
	Height (in m) (2)	Floor area (in m ²) (3)	Cubical Extent (in m ³) (4)	Ground storey or upper storey (5)	Basement storey (6)
Buildings under Purpose Group II					
Line 1 Building or part (+) having not more than two storeys ..	NL	500	NL	½	1
Line 2 Building or part (+) having three storeys	NL	250	NL	1 (b)	1
Line 3 Building having any number of storeys	28	3,000	8,500	1	1 ½
Line 4 Building having any number of storeys	NL	2,000	5,500	1 ½	2

Three 3-storey buildings with the following configurations are used as examples to explain how their periods of fire resistance can be determined.

Building configurations	Height (m)	Floor area (m ²)	Cubicle extent (m ³)
Building A	<28	240	960
Building B	<28	2900	8450
Building C	<28	1900	5400

Example 1 (Building A)

With reference to the Table 3.3A, Part I, the floor area and cubical extents of building A can satisfy the limitations or configurations of lines 2, 3 & 4 of the Table. However, under the 'Notes to Part I', "topmost of those lines" should apply. Hence, the period of fire resistance should be as specified in column (5) and (6) of line 2.

Example 2 (Building B)

Line 2 of the Table 3.3A Part I would not be applicable since the floor area of building B exceeds 250m². Similarly, line 4 is not applicable as its floor area and cubical extent exceeds 2000m² and 5500m³ respectively. Thus, since only line 3 is applicable, the period of fire resistance for building B should be as in column (5) and (6) of line 3.

Example 3 (Building C)

Line 3 and 4 of the Table would be applicable to building C, but, under 'Notes to Part I', "topmost of those lines" should apply. Hence, the period of its fire resistance should be that of column (5) and (6) of line 3.

It should be noted here that, if the overall height of the building exceeds 28m, then the conditions/limitations of line 4 must be complied with, unless otherwise waived by the relevant Authority or provision of automatic sprinkler system is provided to cover the entire building.

Building not more than 2 storeys (e.g basement & 1st storey)

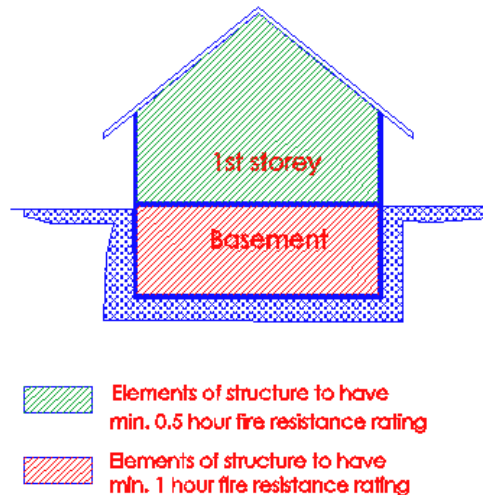

Diagram 3.3A -1

With reference to Table 3.3A, Part I, if the maximum floor area of a storey of a 2 storey building shown above, is less than 500m², then the fire resistance rating stipulated in columns (5) and (6) of line 1 of the Table 3.3A Part I need only be applied. That is, elements of structure above ground level shall have a minimum fire resistance rating of 0.5 hour, and that of the basement, minimum 1-hour fire resistance rating is required.

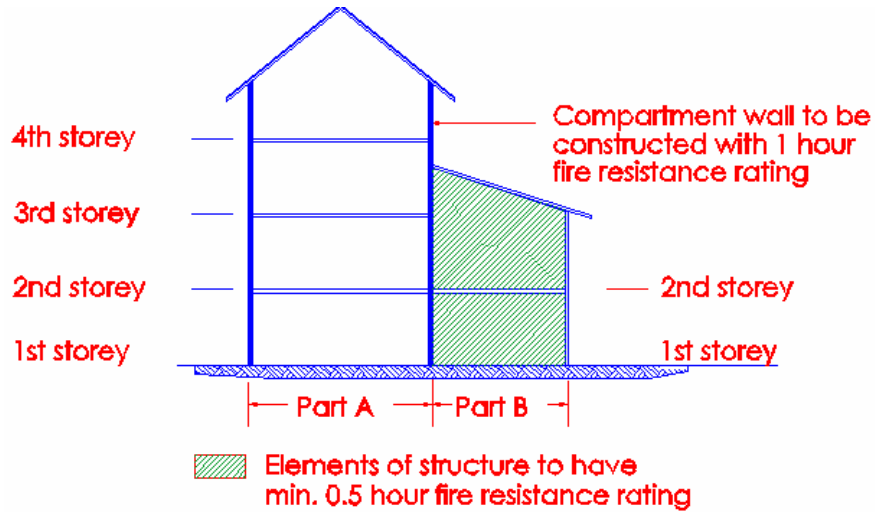

Diagram 3.3A – 2

If the maximum floor area of each compartment does not exceed 500m², then building Part B shall comply with column (5) line 1 of Table 3.3A Part I, while building Part A shall comply with the requirements of line 3. It shall also be noted here that the compartment wall separating the two parts, A and B of the building, shall comply with the minimum fire resistance rating as required for the higher part

(Part A) of the building. This means that the fire resistance rating of column (5) line 3 of Table 3.3A Part I shall be applied to the compartment wall separating Part A and B of the building.

Building of 3 storeys

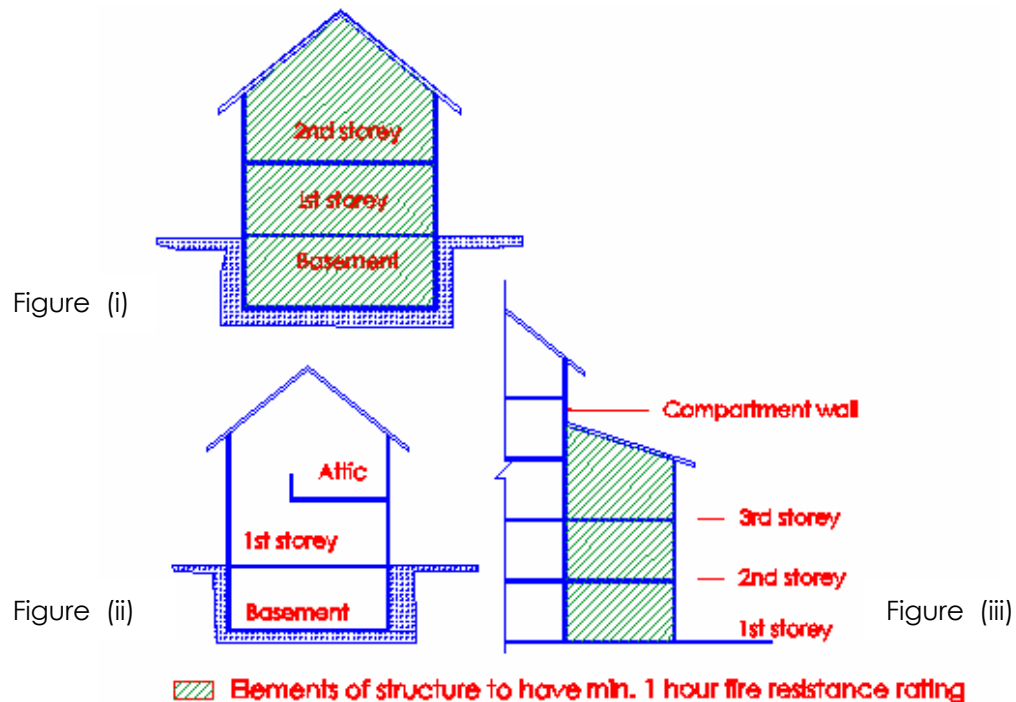

Diagram 3.3A – 3

- (1) As a relaxation to the requirements of Table 3.3A Part I, the floor of the attic of a 2-storey (inclusive of basement) plus attic building can be reduced to half hour fire resistance rating, as it is not a compartment floor. This is allowed on condition that the attic floor slab does not contribute to the support of the building as a whole, in the form of transfer beam.
- (2) Under item (b) of "Notes to Part I" below Table 3.3A Part I, the beams and columns supporting the attic floor shall be constructed to have the same fire resistance rating required of the building. Hence, the beams and columns supporting the attic floor in figure (ii) of above diagram 3.3(A) – 3 shall have 1 hour fire resistance rating.
- (3) Items (1) & (2) above shall only be applicable if the maximum floor area of each compartment of the building does not exceed 250m², in which case, as a relaxation, the fire resistance ratings stipulated in line 2 of Table 3.3A Part I may be applied to the elements of structure of the above 2-storey plus basement building. (Figure (i) and (iii) of diagram 3.3A – 3)
- (4) However, if the floor area of compartment of a 3 storey building or part having 3 storey as shown in figure (I) and (iii) exceeds 250m², the requirements of lines 3 or 4 of Table 3.3A Part I shall be applied accordingly, and the relaxation allowed for non-compartment floors under items (1) & (2) above will not apply.

Building exceeding 3 storeys but not exceeding building height 28m

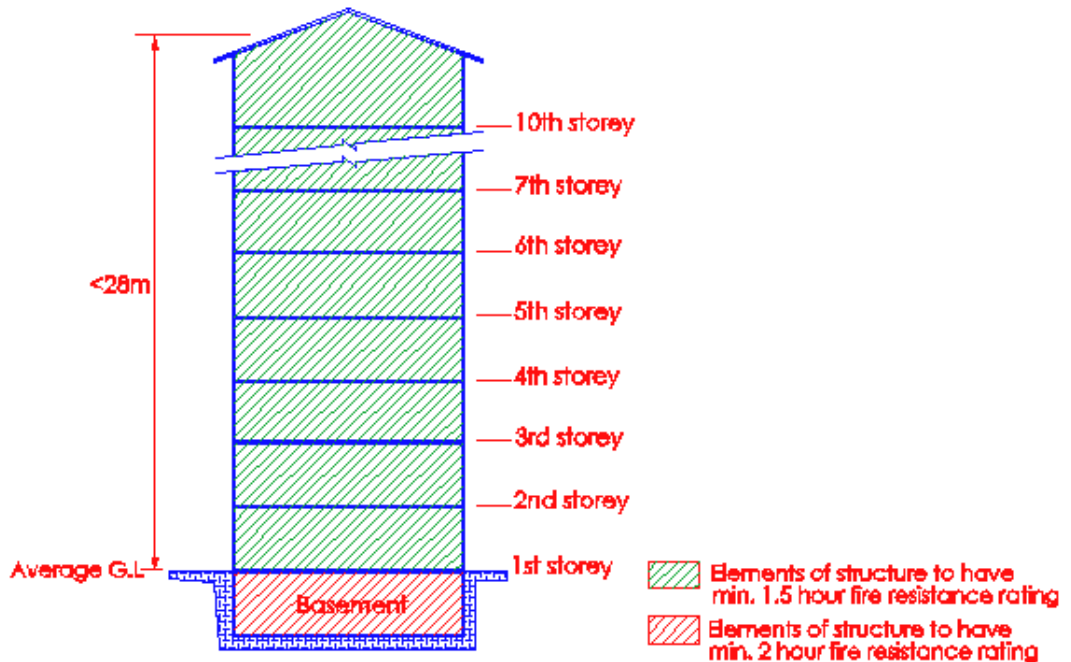

Diagram 3.3A – 4

The period of fire resistance rating specified in the above diagram for a building not exceeding building height 28m is based on columns (5) and (6) of line 3 of Table 3.3A Part I, provided the floor area and cubical extent of each compartment shall not exceed 3000m² and 8500m³ respectively.

Building height exceeding 28m

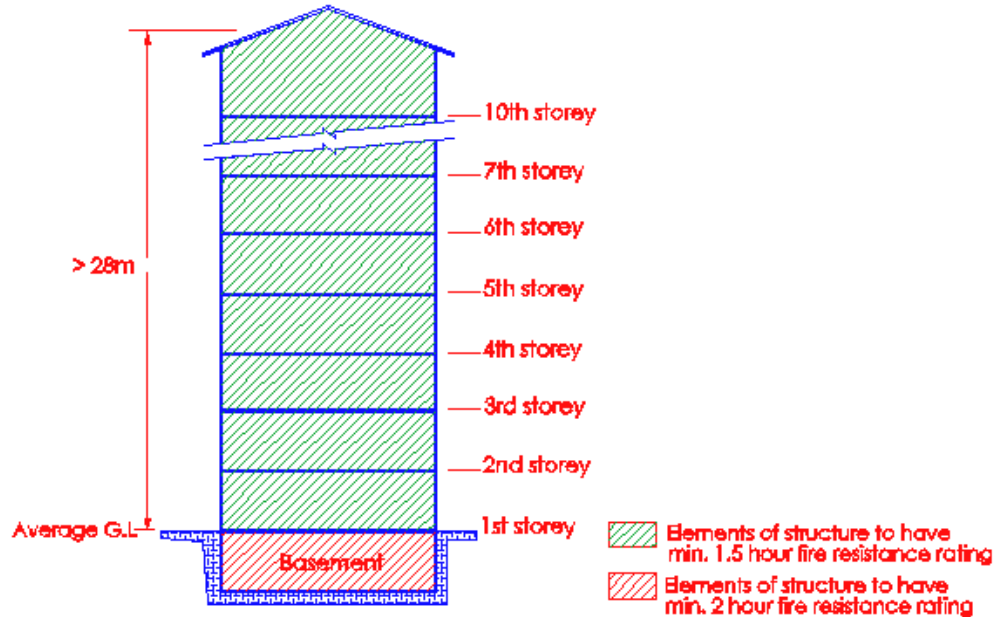

Diagram 3.3A – 5

With reference to line 4 of Table 3.3A Part I, the maximum floor area and cubical extent of each compartment of a building of Purpose Group II, exceeding the building height of 28m shall not exceed 2000m² and 5500m³ respectively, unless otherwise waived by the Relevant Authority or automatic sprinkler system is provided to cover the whole building.

TABLE 3.3A – continued

(Minimum periods of fire resistance)

PART 2 – SINGLE STOREY BUILDINGS

Purpose Group (1)	Maximum floor area (in m ²) (2)	Minimum period of fire resistance (in hours)for elements of structure (3)
II (Other residential)	3,000	½

Notes to Part 2

For the purpose of Cl.3.3.1 the period of fire resistance to be taken as being relevant to an element of structure is the period included in column (3) in the line of entries which specifies the floor the area with which there is conformity or, if there are two or more such lines, in the topmost of those lines.

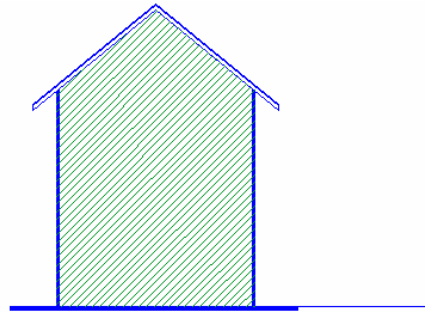

 Elements of structure to have min. 1/2 hour fire resistance rating

The floor area of each compartment shall not exceed 3000m², however, it is not common to have single storey buildings under Purpose Group II.

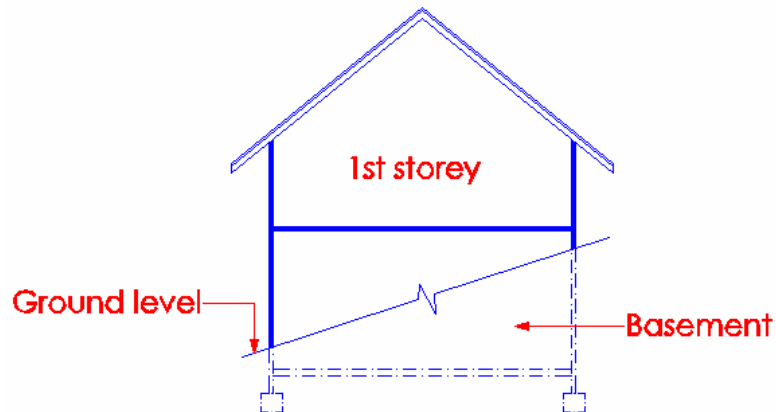

If the building has a basement, it is not a single-storey building for the purpose of working out the fire resistance rating for the elements of structure.

- (a) Any separating wall shall have fire resistance of not less than 1-hour, and

(No illustration)

- (b) Any compartment wall or compartment floor which separates a part of a building falling within Purpose Group II or III from any other part of the building falling within a Purpose Group other than Purpose Group II or III shall have fire resistance of not less than 1-hour.

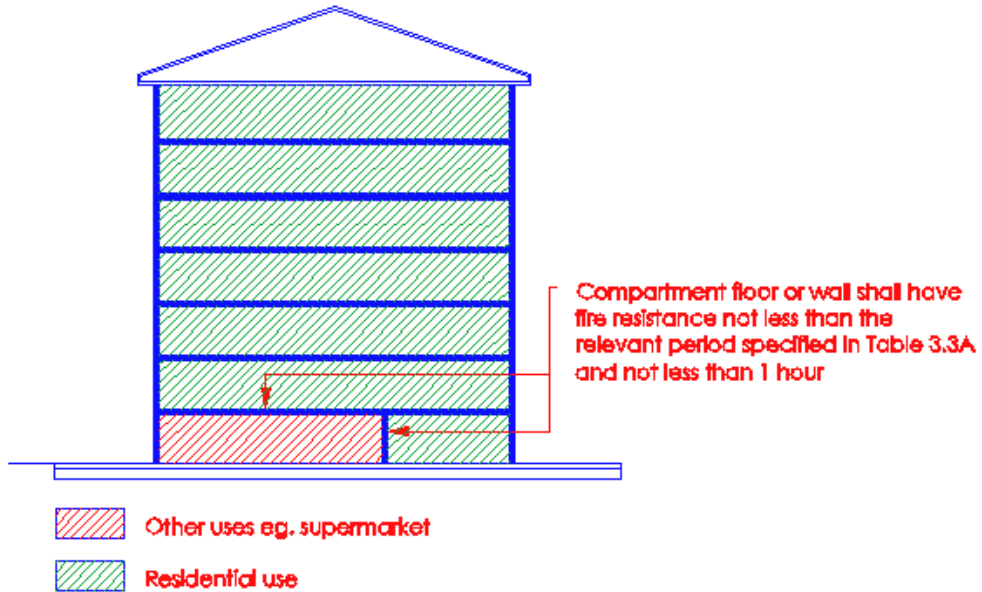

Diagram 3.3.1(b) – 1

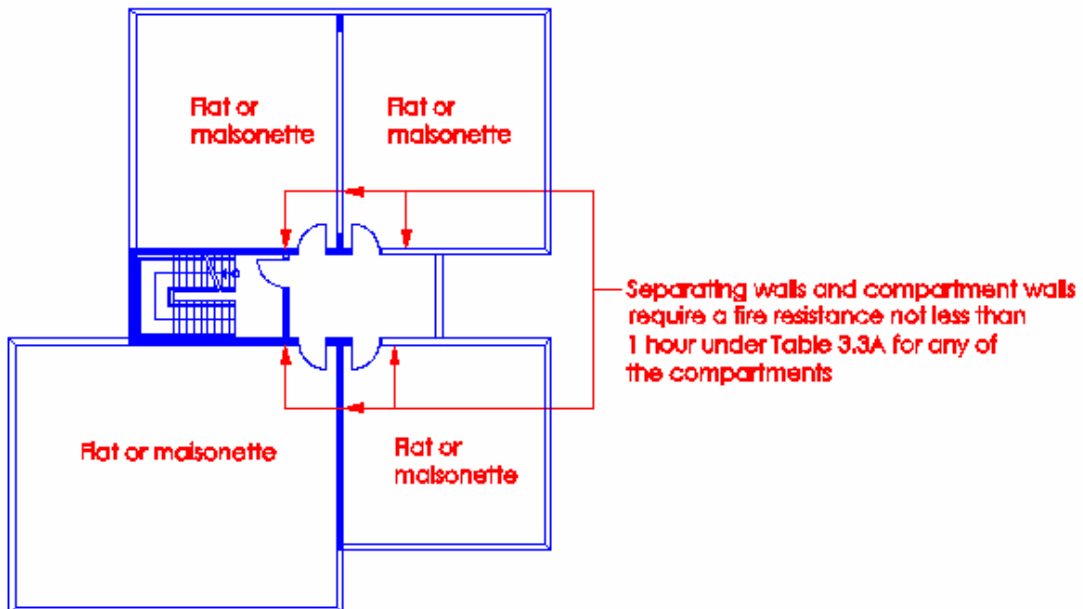

Diagram 3.3.1(b) – 2

3.3.2 Exemption for non-loadbearing external walls

Nothing in Cl.3.3.1 shall apply to any part of any external wall, which is non-loadbearing and may, in accordance with Cl.3.5 be an unprotected area.

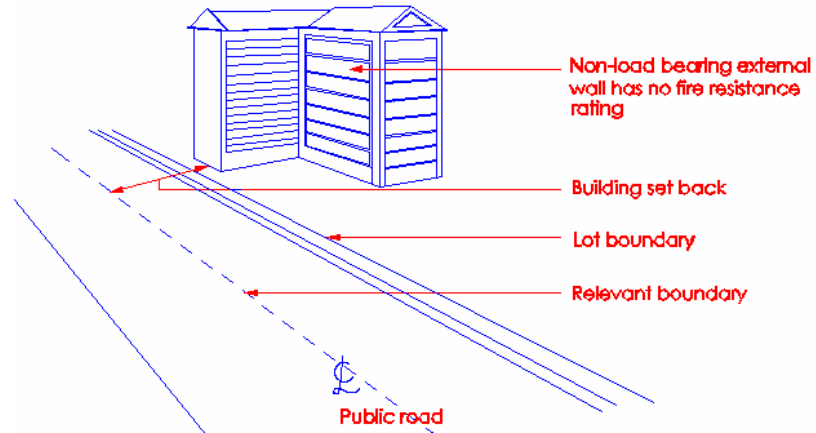

Diagram 3.3.2

Any part of a non-load bearing external wall which constitute the unprotected opening in pursuance to clause 3.5, is not required to have any fire resistance. In the above diagram, the non-load bearing external wall facing the public road need not have fire resistance as it meets Cl.3.5 on set-back requirement, measured from the centre of the public road to the external wall.

3.3.4 The interpretation and application of Cl.3.3 shall be as follows:

- (a) Subject to the provisions of sub-cl.(b) and any other expressed provision to the contrary, any reference to a building of which an element of structure forms a part means the building or (if the building is divided into compartments) any compartment of the building of which an element of structure forms a parts, and

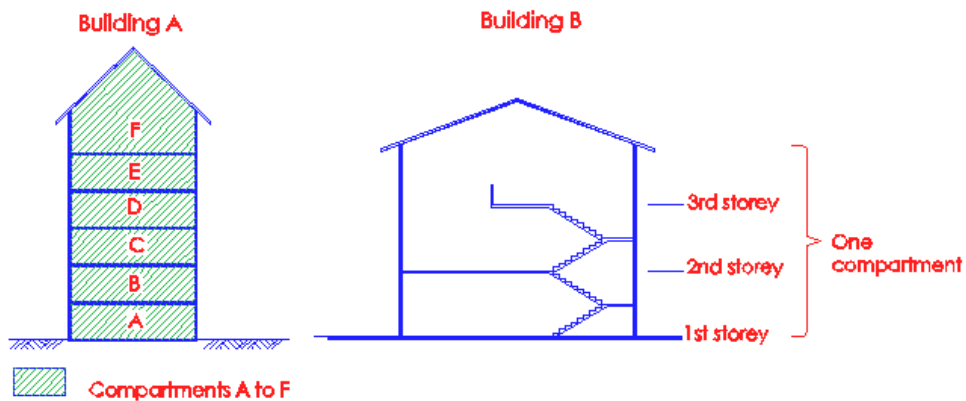

Diagram 3.3.4(a)

Any reference to a building, which is divided into compartments, of which an element of structure forms a part, means that compartment of the building (Building A).

Any reference to a building of which an element of structure forms a part means the building (Building B). It is important to note that any element carrying another element of structure must have at least the same fire resistance as the element it is supporting.

- (b) Any reference to height means the height of a building, but if any part of the building is completely separated throughout its height both above and below ground from all other parts by a compartment wall or compartment walls in the same continuous vertical plane, any reference to height in relation to that part means the height solely of that part, and

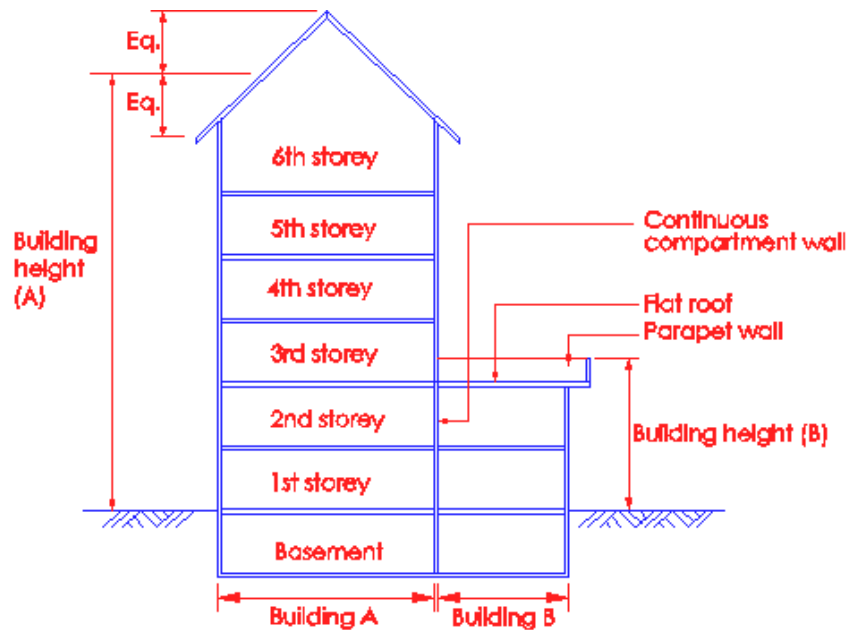

Diagram 3.3.4(b)

The continuous vertical compartment wall divides the building into 2 parts. For building A, any reference to height means the building height (A). For building B, any reference to height means the building height (B).

- (c) If any element of structure forms part of more than one building or compartment and the requirements of fire resistance specified in Table 3.3A in respect of one building or compartment differ from those specified in respect of any other building or compartment of which the elements forms a part, such element shall be so constructed as to comply with the greater or greatest of the requirements specified.

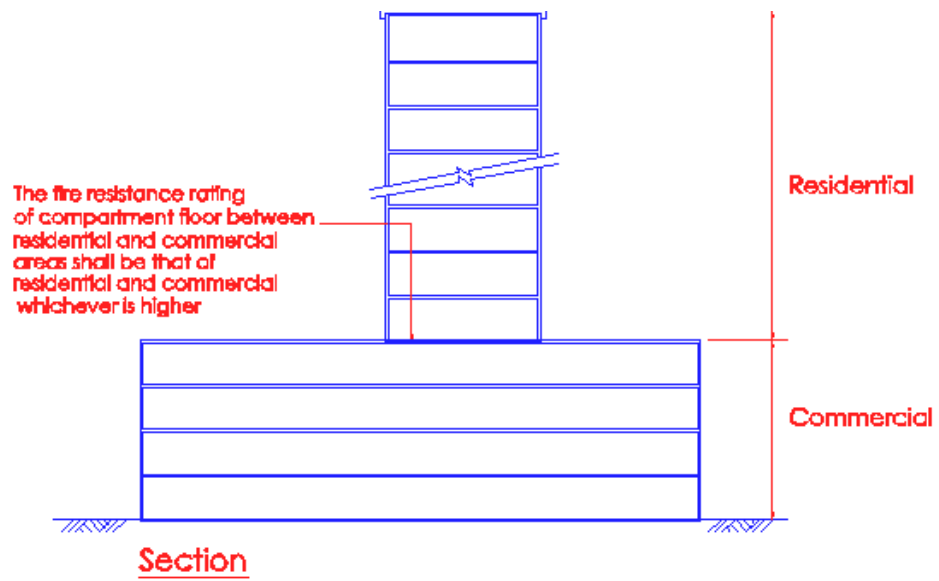

Diagram 3.3.4(c) – 1

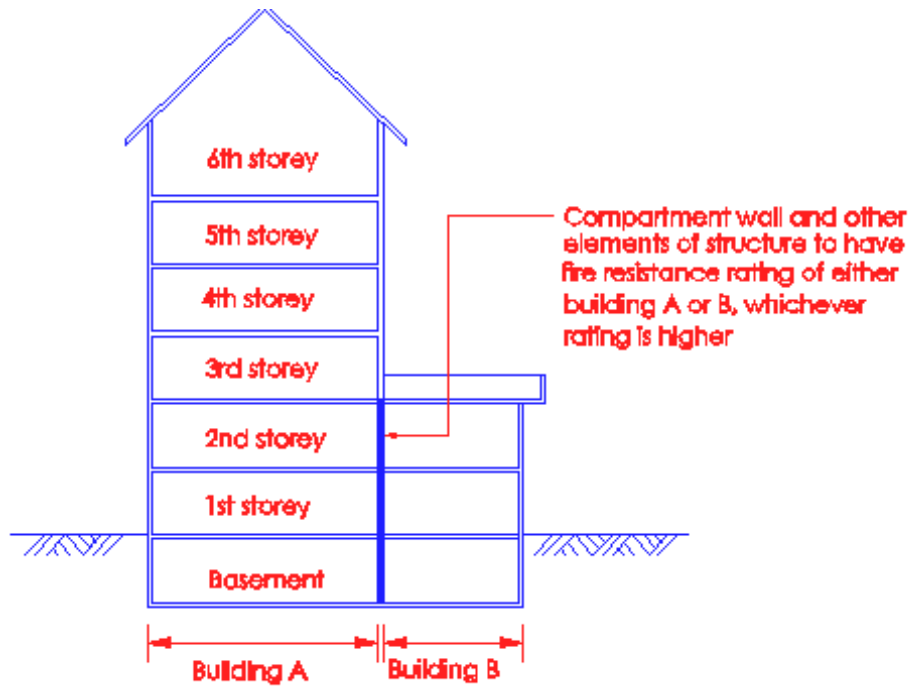

Diagram 3.3.4(c) – 2

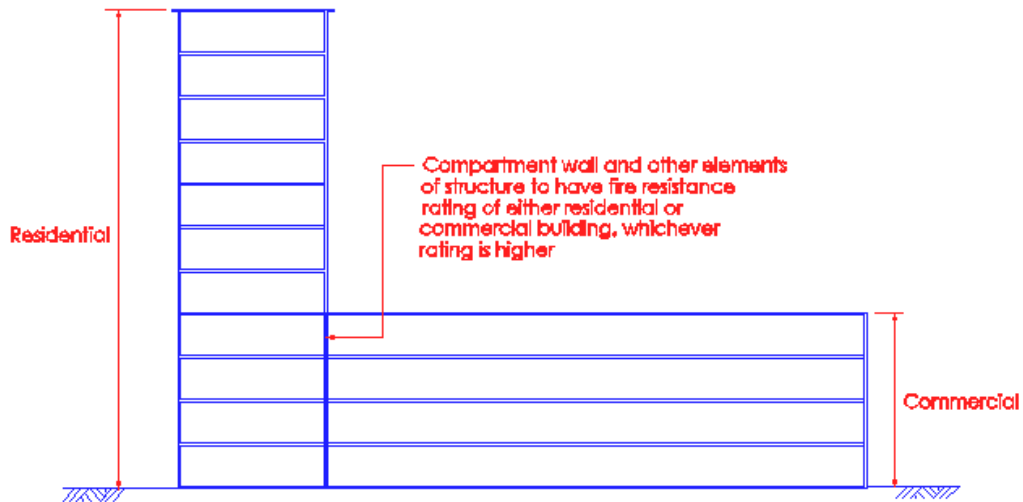

Diagram 3.3.4(c) – 3

3.3.5 Any compartment wall separating a residential apartment or maisonette from any other part of the same building, shall not be required to have fire resistance exceeding 1 hour unless -

- (a) The wall is a wall forming part of a protected shaft and the minimum period of fire resistance required by the provisions of this code for the protecting structure is more than 1 hour, or
- (b) The part of the building from which the wall separates the residential apartment or maisonette is of a different purpose group and the minimum period of fire resistance required by the provisions of this code for any element of structure in that part is more than 1 hour.

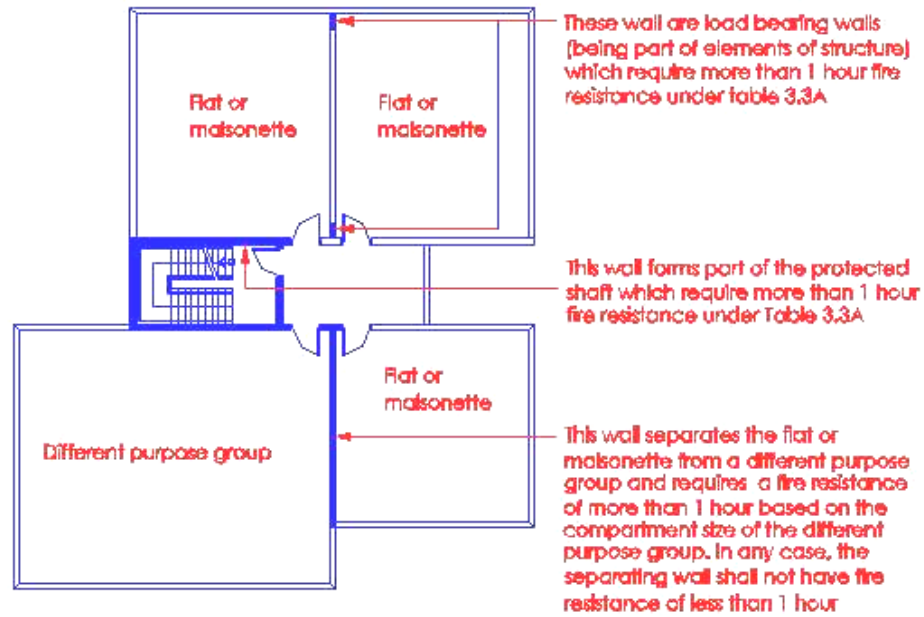

Diagram 3.3.5

3.3.6 Suspended ceiling

In determining the fire resistance of floors, no account shall be taken of any fire resistance attributable to any suspended ceiling unless the ceiling is constructed specifically as a fire protecting suspended ceiling and the construction complies with the requirements under Table 3.3B for Limitations on Fire Protecting Suspended Ceilings.

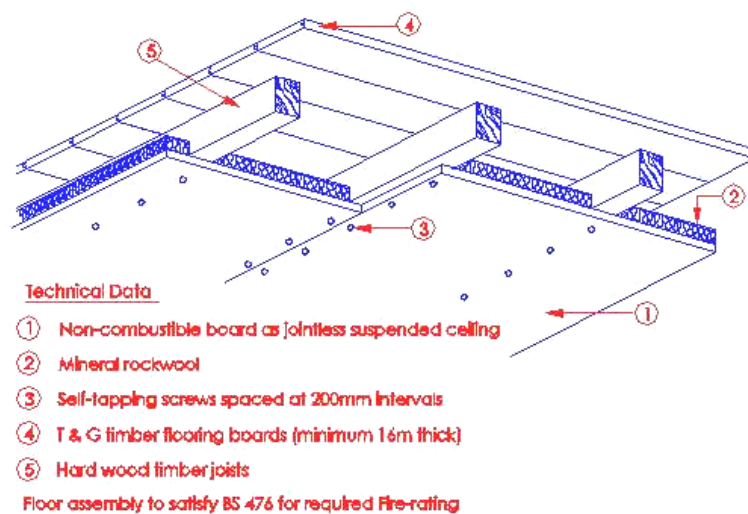

Diagram 3.3.6

The ceiling shown in diagram 3.3.6 above, shall be constructed specifically as a fire protecting membrane and comply with Table 3.3B on limitation of fire protecting suspended ceiling. As the ceiling is intended as a protecting membrane, the concealed ceiling space shall not be used for recessed lighting and other service, such as air-con ducts, cables, pipes etc, even if these services are housed in fire rated enclosures.

Where the space above a suspended ceiling (non-fire rated) is protected by an automatic sprinkler system it shall be exempted from the requirements for non-combustibility and surface spread of flame classification as specified in the above Table, provided the ceiling is not situated over an exit passageway, protected lobby or other required protected means of escape, and that the ceiling space is not used as an air-plenum.

The implications of clause 3.3.6 are that the normal type of suspended ceiling consisting of separate tiles cannot be counted as contributing to the fire resistance of the floor in buildings over 15m high where the period required is one hour; or in buildings of any height where the period required is more than one hour. In these circumstances only jointless ceilings can be considered as contributing.

The above diagram showing protective ceiling being added to the underside of a timber floor, shall apply only in buildings under conservation where retention of the timber floor is required, and in buildings under Purpose Groups I & II for the construction of attic.

Suspended Ceilings which are contributing to the fire resistance rating of the floor under Table 3.3B

Height of building less than 15m

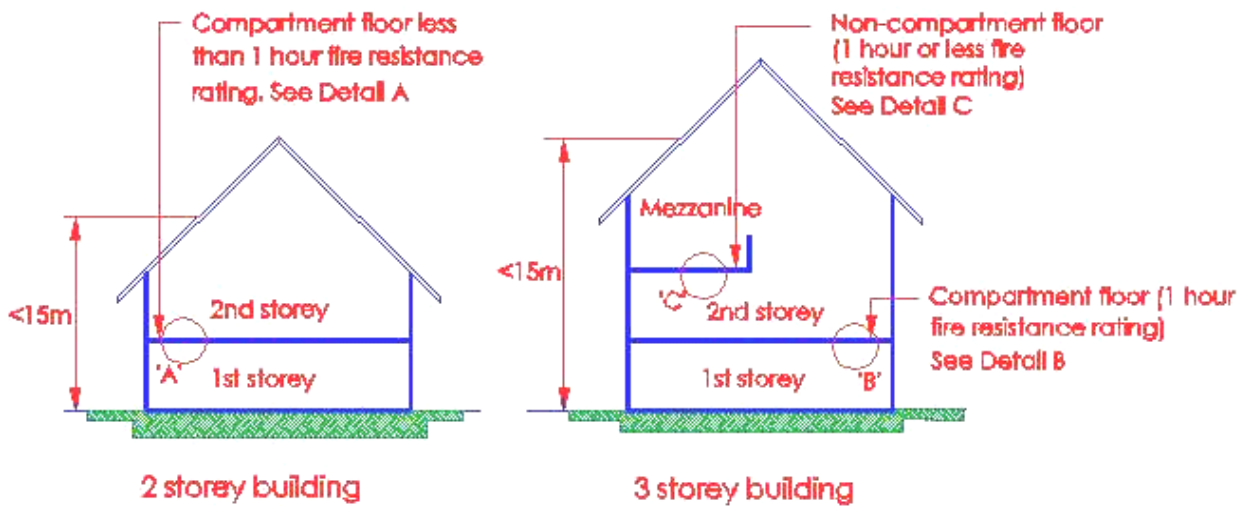

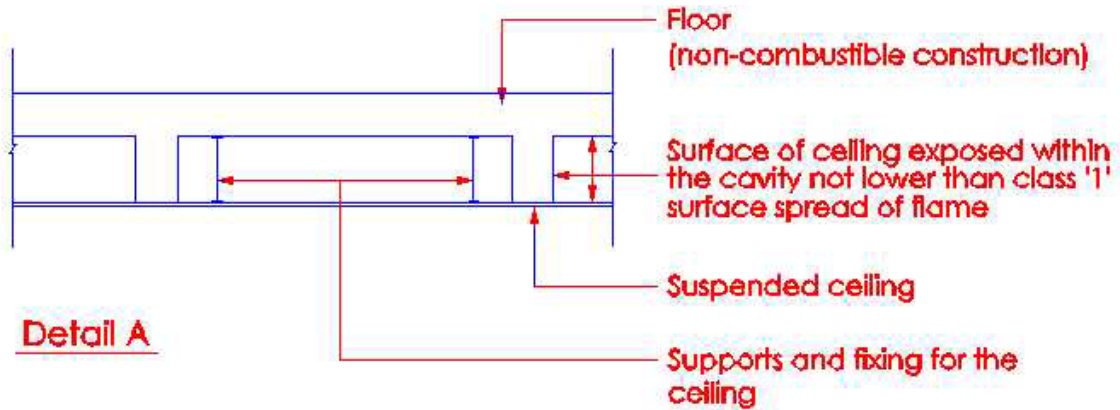

Compartment floor requiring less than 1 hour fire resistance rating

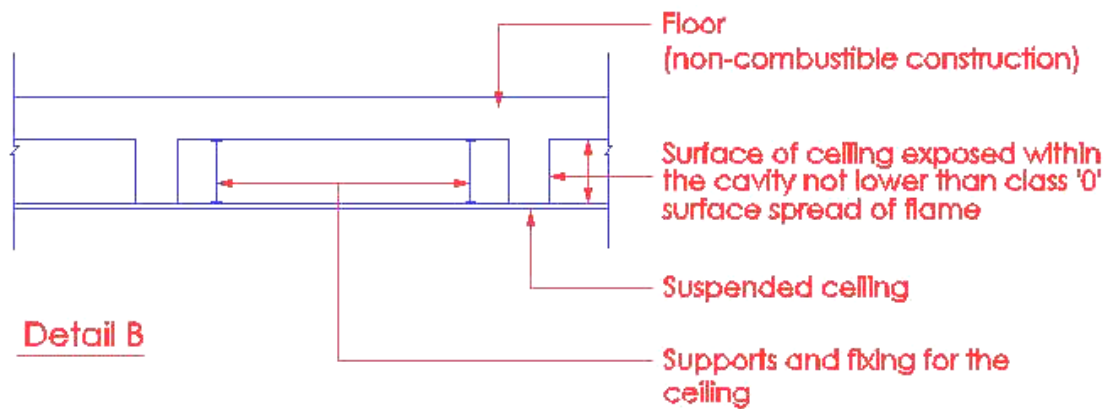

Compartment floor requiring 1 hour fire resistance rating

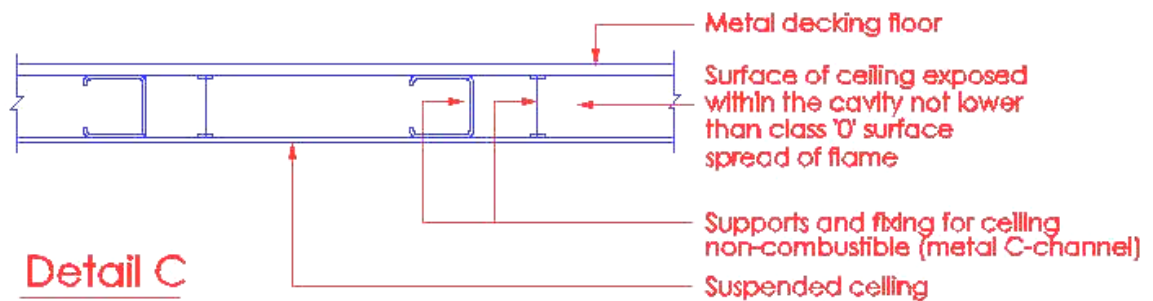

Non-compartment floor requiring 1 hour or less fire resistance rating

Height of building – 15m or more

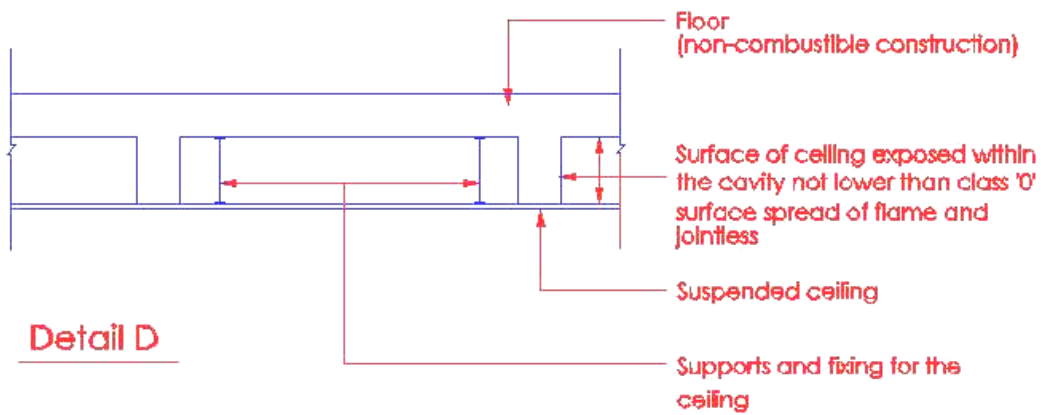
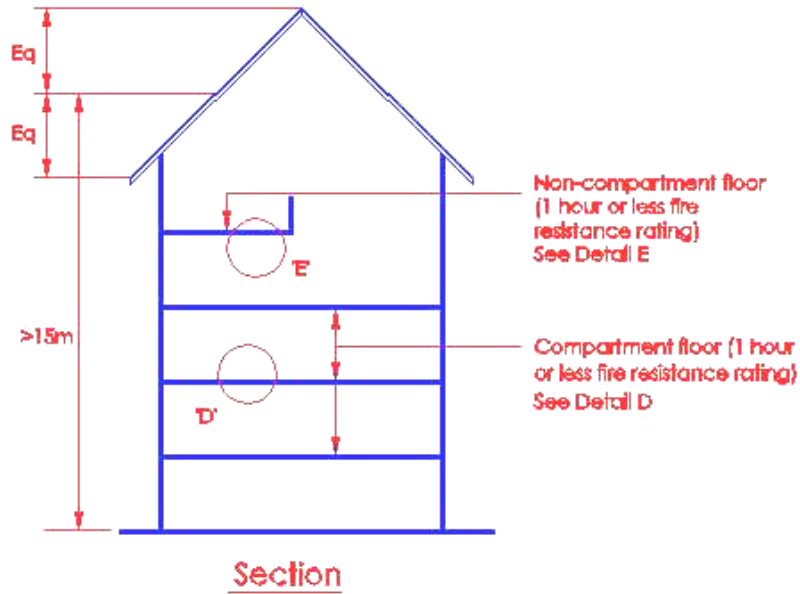

Compartment floor requiring 1 hour or less fire resistance rating

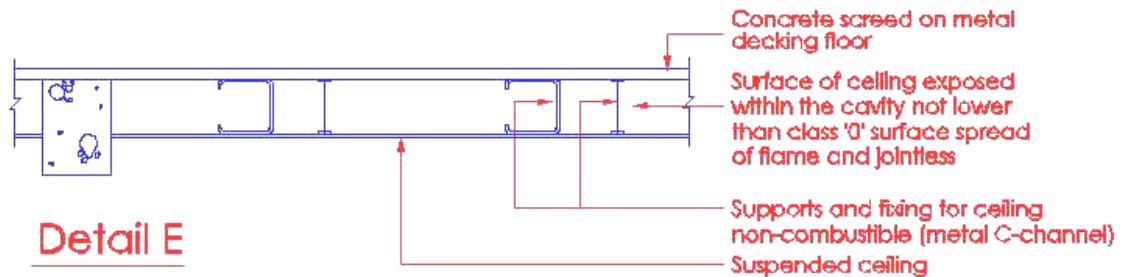

Non-compartment floor requiring 1 hour or less fire resistance rating

Height of building – any height

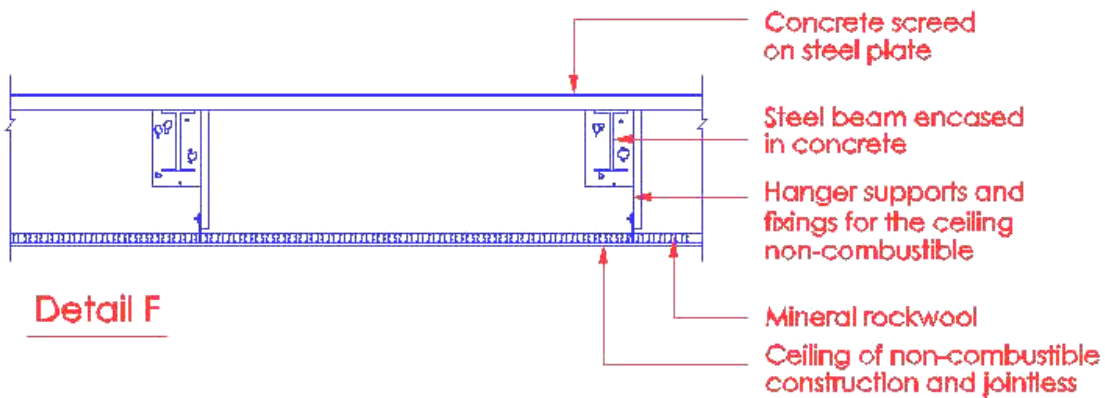
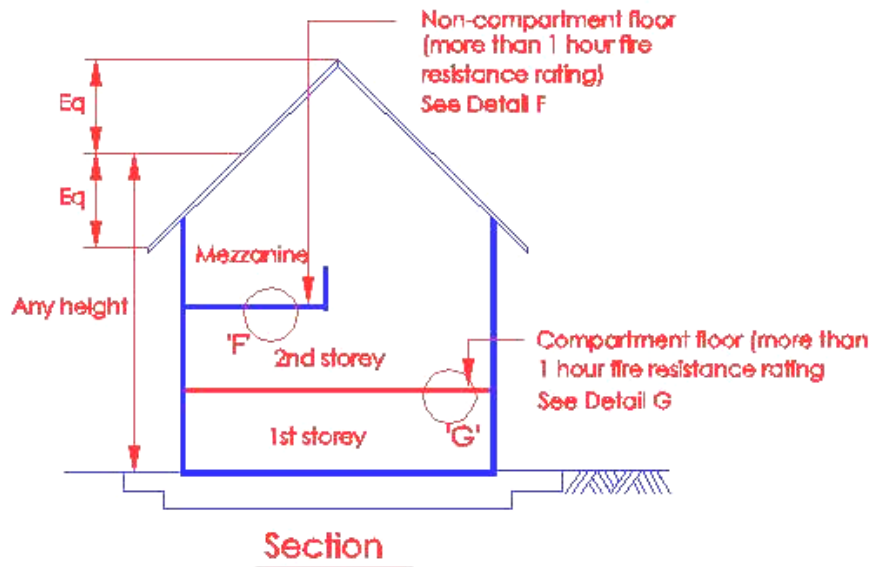

Non-compartment floor requiring more than 1 hour or less fire resistance rating

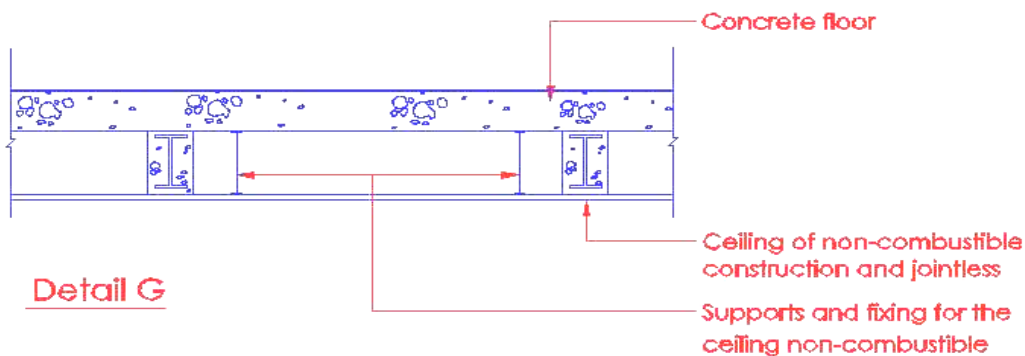

Compartment floor requiring more than 1 hour fire resistance rating.

The foregoing diagrams illustrate the intent of the clause which basically deals with the contribution by suspended ceilings to the fire resistance of floors. The provision of suspended ceilings for the protection of the floors shall be treated differently from that provided for the protection of structural steel works in the ceiling space.

3.4 TEST OF FIRE RESISTANCE

3.4.1 Fire resistance

Performance for the fire resistance of elements of structure, doors and other forms of construction shall be determined by reference to the methods specified in BS 476:Part 20 to 23, which specify tests for stability, integrity and insulation.

Specific requirements for each element in terms of the three performance criteria of stability, integrity and insulation are given in Table 3.4A,

(No illustration)

In conjunction with Part 20, methods of test are provided for – Beams, columns, floors, flat roofs and walls(Part 21); Partitions, doorsets and vertical shutter assemblies, ceiling membranes and glazed elements(Part 22); and Suspended ceilings protecting steel beams and intumescent seals for use in conjunction with single acting latched timber fire-resisting door assemblies(Part 23).

Part 20 specifies standard heating conditions based on a temperature/time curve (Diagram 3.4.1) which furnaces are required to follow; the temperature at defined locations close to the exposed face of the specimen under test rising to 821°C after 30 minutes and 1133°C after four hours.

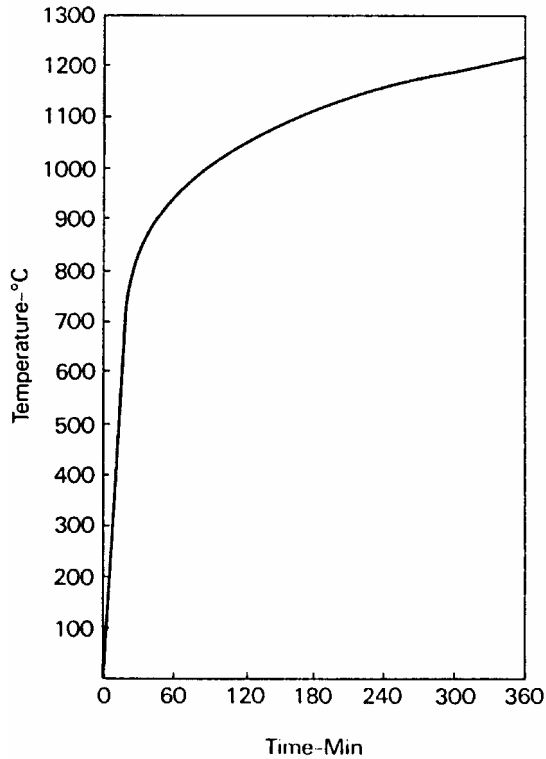

Diagram 3.4.1

Standard temperature/time curve (BS 476: Part 20)

The specimen to be tested should be either full size or, where the element exceeds the size that can be accommodated by the furnace, it must have the following minimum dimensions.

Non-separating elements: Vertical 3m high
Horizontal 4m span

Separating elements: Vertical 3m high X 3m wide
Horizontal 4m high X 3m wide

Specimens are normally heated to simulate their exposure in a fire, eg walls from one side, floors from beneath and columns from all sides.

Elements of building construction are required to satisfy various criteria according to their designed function in the event of fire. These are:

- “Stability” or “Loadbearing capacity” - the ability of a loadbearing element to support its test load without excessive deflection;
- “Integrity” - the ability of a separating element to resist collapse, the formation of holes, gaps or fissures through which flames and/or hot gases could pass, and the occurrence of sustained flaming on the unexposed face (the side of the specimen remote from the furnace)

"Insulation"

- *the ability of a separating element to resist an excessive rise in temperature on its unexposed face.*

The criterion of "stability" or "loadbearing capacity" is applied only to loadbearing elements. For floors, flat roofs and beams, allowable vertical deflection is limited to 1/20 clear span.

Loss of "integrity" in the context of the formation of holes, gaps or fissures is judged by ignition of a cotton fibre pad. Where this test is not suitable, failure is deemed to have occurred if either a 25mm diameter gauge can penetrate into the furnace through a gap at any point, or a 6mm diameter gauge can penetrate into the furnace through an opening and can be moved for a distance of at least 150mm.

Loss of "insulation" occurs when the temperature on the unexposed face (the side of the specimen remote from the furnace) increases by more than 140°C (mean) or by more than 180°C at any point. Loss of "integrity" also constitutes loss of "insulation".

Columns and beams have to satisfy only the criterion of "loadbearing capacity"; glazed elements are normally required to satisfy only "integrity"; and floors and walls have to satisfy all three criteria. It is pertinent to note that under Table 3.4A, doors are only required to satisfy "integrity", leaving aside "insulation" as it is assumed unlikely that combustible materials would be stored against them. However, doors to protected lobbies, exit staircases and exit passageways should be provided with insulation against transmission of heat by radiation from the fire floor into the protected enclosures which occupants use for evacuation.

It is important to note that fire rated glass door shall not be used in protected lobbies, exit staircases and exit passageways.

3.4.2 "Deem to satisfy" provisions

An element of structure, door or other part of a building shall be deemed to have the requisite fire resistance if -

- (a) It is constructed to the same specification as that of a specimen exposed to test by fire in accordance with the method and procedure under BS 476: Part 20 to 23, and satisfied the requirements of that test for the three performance criteria of stability, integrity and insulation for not less than the specified period , or

- (b) In the case of a wall, beam, column, stanchion or floor to which Appendix A to Cl. 3.4 relates, it is constructed in accordance with one of the specification set out in that Appendix and the notional period of fire resistance given in that Appendix as being appropriate to that type of construction and other relevant factors is not less than the specified period.

(No illustration)

Subclause 3.4.2(b) provides the alternative to complying with the specification of tested prototype under BS476 Part 20 to 23. Specification set out in Appendix A to Cl.3.4 could be used and there is no need to obtain separate testing. However, on completion of the building works, the qualified person concerned is to forward to FSSD his/her certificate of supervision that the relevant specification listed in Appendix A to Cl. 3.4 had been complied with on site when applying for TFP or FSC.

3.4.3 Timber floors

The use of timber floors shall not be allowed, except:

- (a) for an attic in buildings; and
- (b) in buildings designated for conservation where the timber floors are required to be retained, but subject to compliance with the technical guidelines for 'FIRE SAFETY REQUIREMENTS AFFECTING SHOPHOUSES UNDER CONSERVATION.'

(See Cl.2.4.12 and Cl.3.3.6)

3.5 EXTERNAL WALL

3.5.1 Requirements of External Walls shall be as follows:

- (a) Any external walls of a building or a separated part of a building which constitutes or is situated within a distance of 1m from any point on the relevant boundary, or is a wall of a building or a separated part of a building which exceeds 15m in height shall-
 - (i) be constructed wholly of non-combustible materials apart from any external cladding which complies with Cl.3.5.4 or any internal lining which complies with Cl.3.13.4, and

- (ii) be so constructed as to attain the fire resistance required by this chapter, and

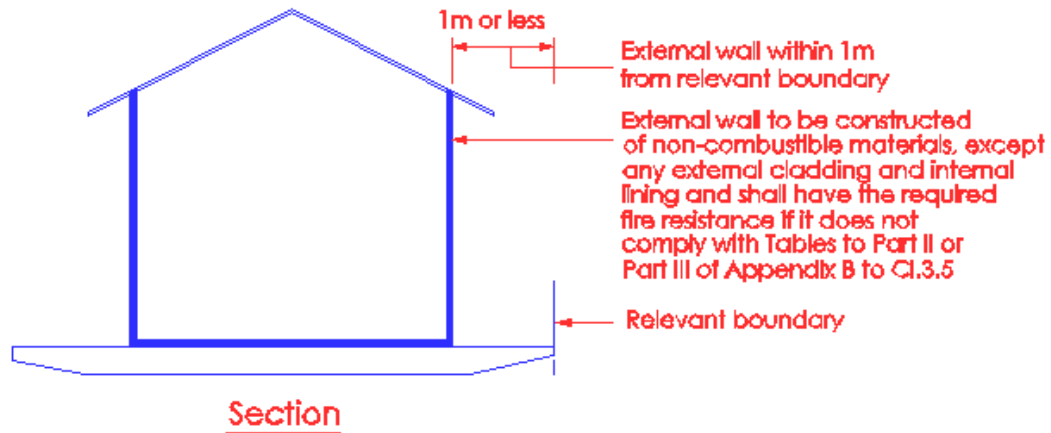

Diagram 3.5.1 – (1)

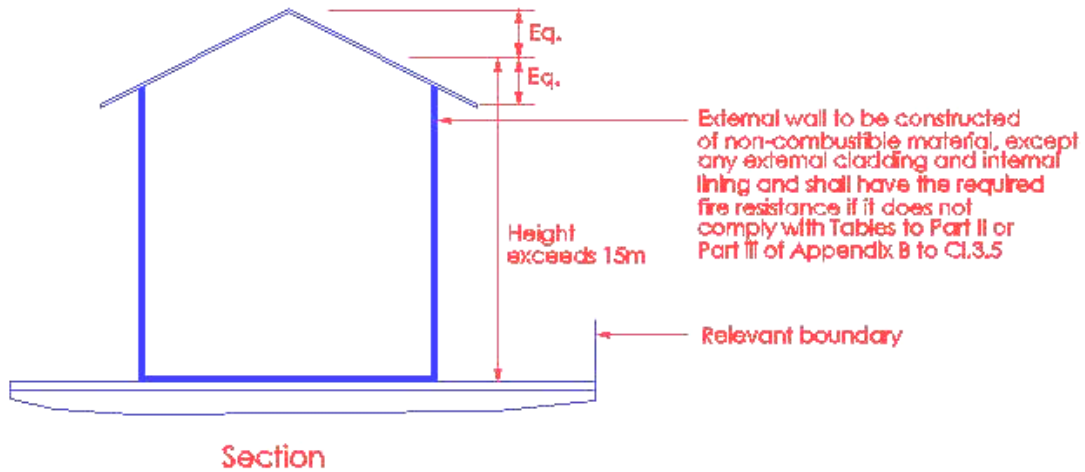

Diagram 3.5.1 – (2)

- * External wall of a building which exceeds 15m in building height or is within 1m of the relevant boundary shall be constructed wholly of non-combustible materials, apart from any external combustible cladding under Cl.3.5.4 or internal combustible lining under Cl.3.13.4.
- * The external shall be imperforate, free of any unprotected area and have the necessary fire resistance rating, both inside and outside. The required fire resistance shall be achieved by the non-combustible part alone.
- * The external wall shall have the necessary fire resistance rating as follows:
 - (i) Building not more than 2 storey – ½ hour
 - (ii) Building more than 2 storey, but less than 28m in building height – 1 hour
 - (iii) Building above 28m building height 1½ hour.

- * *The whole or part of an external wall need not have fire resistance rating and can be treated as unprotected area (such as windows etc) if it is adequately separated from the relevant boundary in accordance with Table 1 to Cl.3.5 of the Fire Code. Walls which are more than 1m from a boundary need to resist the effect of fire from the inside only.*

- 3.5.1 (b) Any beam or column forming part of an external wall and any structure carrying an external wall which is required to be constructed of non-combustible material, shall comply with the provisions of sub-cl. (a)

(No illustration)

Any beam or column forming part of an external wall and any structure carrying an external wall shall be constructed of non-combustible materials and have the necessary fire resistance rating of elements of structure, apart from any external cladding which complies with Cl.3.5.4 or any internal lining which complies with Cl.3.13.4. The required fire resistance shall be achieved by the non-combustible part alone.

3.5.2 Exceptions

The requirements of Cl. 3.5.1(a)(I) for non-combustibility of external walls shall not apply to the external wall of a building or separated part of a building-

- (a) if that wall is:
 - (i) situated 1m or more from the relevant boundary; and
 - (ii) not exceeding 15m in height; and
 - (iii) separated as described in cl.3.3.4(b); or
- (b) if that wall is situated 1 m or more from the relevant boundary:
 - (i) of purpose group II of not more than three storeys, or

Purpose Group II building not exceeding 3 storey and building height 15m

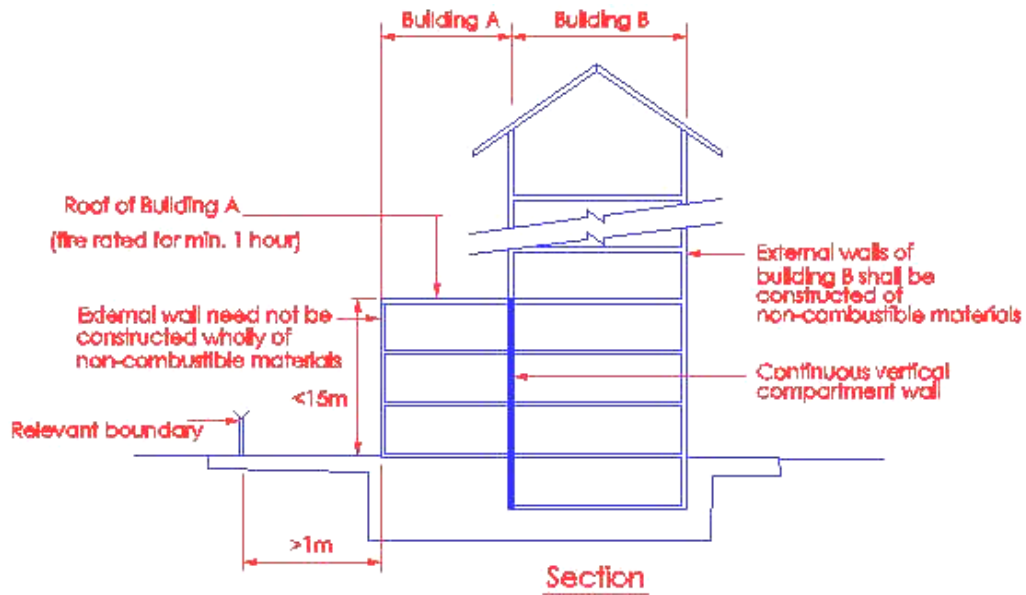

Diagram 3.5.2(a)

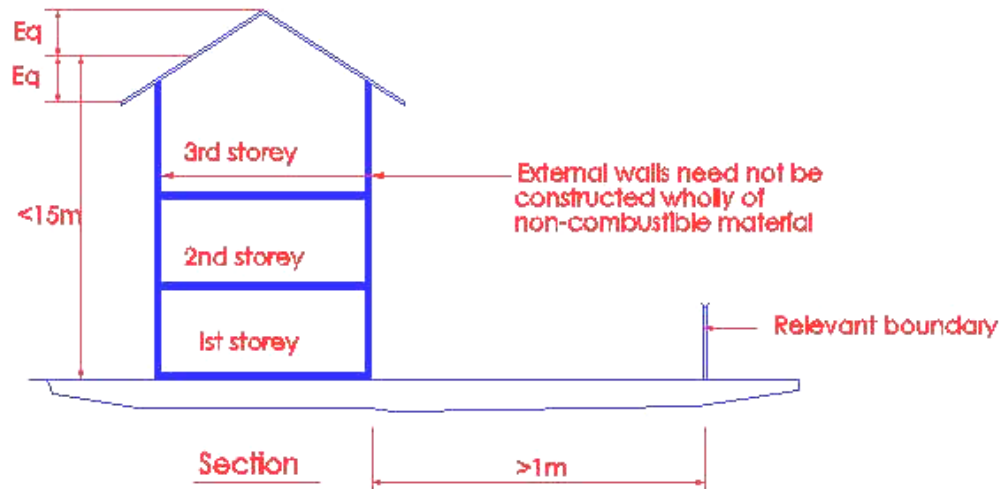

Diagram 3.5.2(b)

Part of a Purpose Group II building (not exceeding 3 storey – building A in diagram 3.5.2(a)), separated from the other parts by vertical compartment wall. Exemption would also apply to the separated part of building A in diagram 3.5.2(a) which shall not exceed 3 storey in height and be situated 1m or more from the relevant boundary.

3.5.3 Unprotected areas in any side of a building

Except where otherwise provided, unprotected areas in any side of a building shall comply with the following:

- (a) Any relevant requirements relating to the permitted limits of unprotected areas specified in Appendix B unless the building is so situated that such side may in accordance with Appendix B consists entirely of any unprotected area, and

(No illustration)

Unprotected areas in relation to a side or external wall of a building means:

- (i) a window, door or other opening, and*
- (ii) any part of the external wall which has less than the relevant fire resistance required in cl.3.5, and*
- (iii) any part of the external wall which has combustible material more than 1mm thick attached or applied to its external face whether for cladding or any other purpose*

The extent of unprotected areas in the external wall in relation to the setback from relevant boundary or lot boundary shall be in accordance with Appendix B to Cl.3.5. The further the building is setback from the relevant boundary, the greater the amount of unprotected areas would be permitted.

The intensity of the heat produced by a fire within a building which can reach the relevant boundary will depend upon the extent of the "unprotected areas" in the external walls and the distance between these walls and the relevant boundary. The heat flux at the relevant boundary shall be less than that normally required for pilot ignition of combustible material after a period of exposure.

Thus, there is need to control the extent of "unprotected area" which can be permitted in relation to the distance from the relevant boundary.

In situations where the extent of unprotected areas in external walls do not comply to Appendix B, the qualified person has 4 alternatives. These are:

- (a) reduce the total unprotected area; or*
- (b) increase the distance from the relevant boundary; or*
- (c) introduce compartmentation within the building to break up the size of enclosing rectangle or*
- (d) introduce automatic sprinkler system so that the unprotected areas can be doubled or the distance from the relevant boundary can be reduced by half.*

3.5.3 (b) The extent of unprotected openings in an external wall of a building or compartment in relation to its distance from the lot boundary may be double that which is specified in Appendix B when the building or compartment is :

(ii) fitted throughout with an automatic sprinkler system in compliance with the requirements in Chapter 6.

For subclause b(ii), more relaxation is granted with installation of sprinkler system taking into consideration the expected fire size.

(c) As an alternative to (b)(ii) above, the distance between the external wall of a building and the relevant boundary may be half that specified in Appendix B if the building is fitted throughout with an automatic sprinkler system in compliance with the requirements in Chapter 6.

(No illustration)

The above clause is to provide an alternative for buildings protected with sprinkler system. Qualified Person/Building owner shall decide which option, clause (b) or (c) i.e either double the unprotected openings or half the separation distance between the building and the relevant boundary, whichever is relevant to the building.

3.5.4 Cladding on External Walls shall comply with the following:

(a) Cladding on external walls

If such cladding is situated less than 1 m from any point on the relevant boundary, it shall have surface complying with the requirements for Class `0', and

(b) If such cladding is situated 1 m or more from the relevant boundary it shall have, if the building is more than 15 m in height, a surface complying with the requirements specified for Class `0', except that any part of such cladding below a height of 15 m from the ground may consist of timber of not less than 9 mm finished thickness or of a material having a surface which, when tested in accordance with BS 476: Part 6 have an index of performance (I) not exceeding 20.

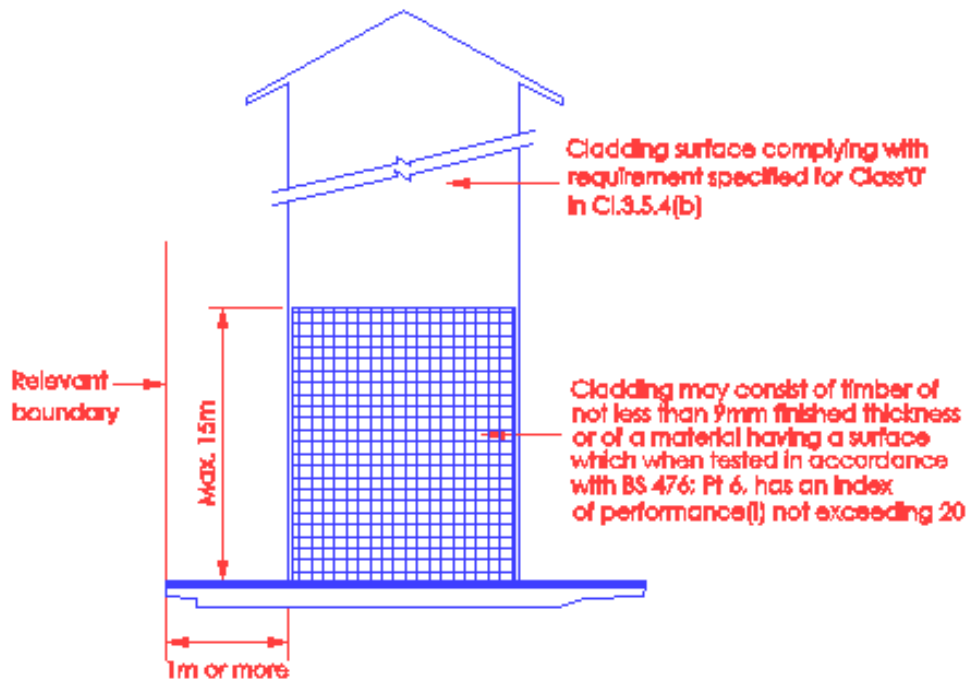

Diagram 3.5.4(a)

If such cladding is situated 1m or more from the relevant boundary and the building is more than 15m,

- (i) any part that is situated above 15m from the ground shall have a surface complying with the requirements for Class '0'.
- (ii) any part that is situated below a height of 15m from the ground may consist of timber of finished thickness of not less than 9mm or of a material having a surface which, when tested in accordance with BS 476 Pt 6 has an index of performance (I) not exceeding 20. The index of performance is derived from the fire propagation test which provides a comparative measure of the contribution a material will make to the heat build-up and thus to fire spread within a room or space
- (iii) Values of index of performance (I) range in descending order of merit from '0' (non-combustible material eg. metal) to '100' (highly combustible material). For example, 13mm thick fibre insulation board has an index of performance (I) 66.4, 18mm thick hardwood has the value of 34.9 and 13mm thick plaster board has the value of 9.9.

APPENDIX 'B' TO CL.3.5
PART 1
CALCULATION OF PERMITTED LIMITS OF UNPROTECTED AREAS

General rules applicable to this Appendix

1. The permitted limit of unprotected areas in any side of a building or compartment shall be calculated by reference to the requirements of Part II or III (whichever is applicable under Cl.3.5)

Unprotected Areas in External Wall

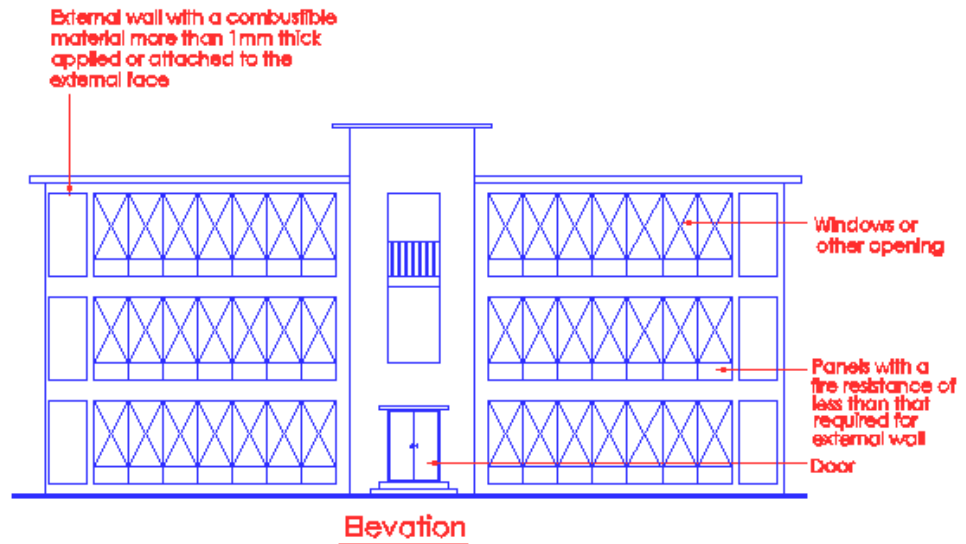

2. For the purpose of this Appendix, the expression "unprotected area" has the meaning ascribed to it by Cl.1.2.61, but in calculating the size of unprotected areas or the permitted limit of unprotected areas, the following provisions shall apply -
 - (a) Where any area of an external wall is an unprotected area, only because it has combustible material attached to it as cladding, the area shall be deemed to be half the area of such cladding;

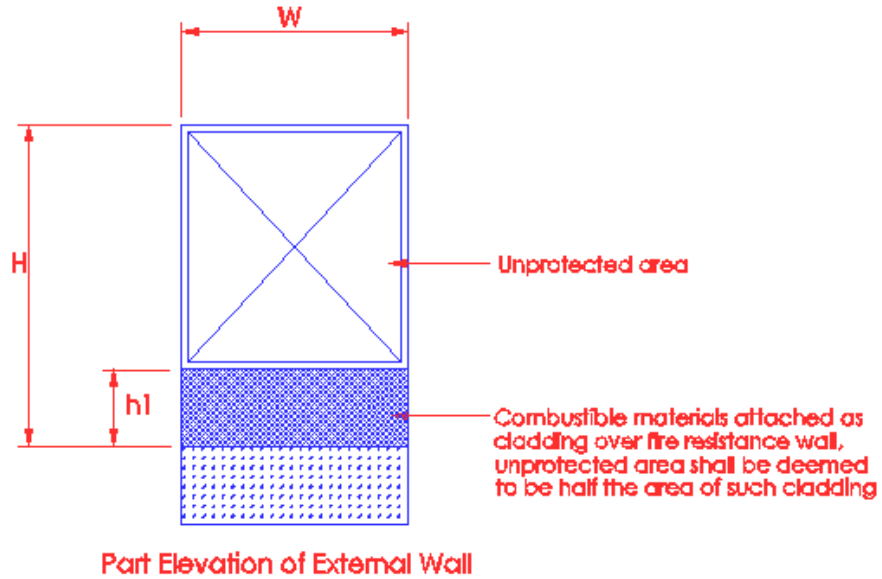

Diagram 2(a) Pt.I Appendix B

$$\text{Total unprotected area} = W \times H - \frac{1}{2} (W \times h_1)$$

(b) No account shall be taken of the following –

- (i) an unprotected area which does not exceed 0.1m^2 and which is not less than 1.5m from any other unprotected area in the same side of the building or compartment (unless that other falls within (iii) below);
- (ii) one or more unprotected areas having an areas (or, if more than one, the aggregate area) not exceeding 1m^2 and not less than 4m from any other unprotected area in the same side of the building or compartment (except any such area as is specified in (1) above);
- (iii) an unprotected area in any part of an external wall which forms part of a protected shaft;
- (iv) an unprotected area in the side of a building not divided into compartments, if the area is not less than 28m above any ground adjoining that side of the building.

No account shall be taken of the following :-

- (i) Unprotected area not exceeding 0.1m² and not less than 1.5m from other unprotected area

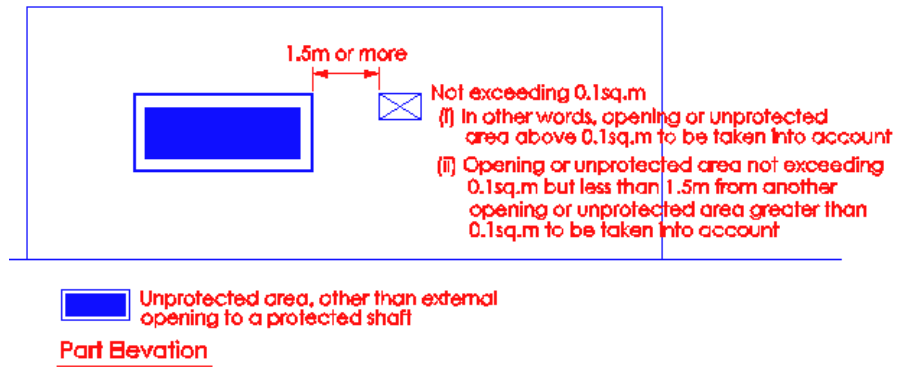
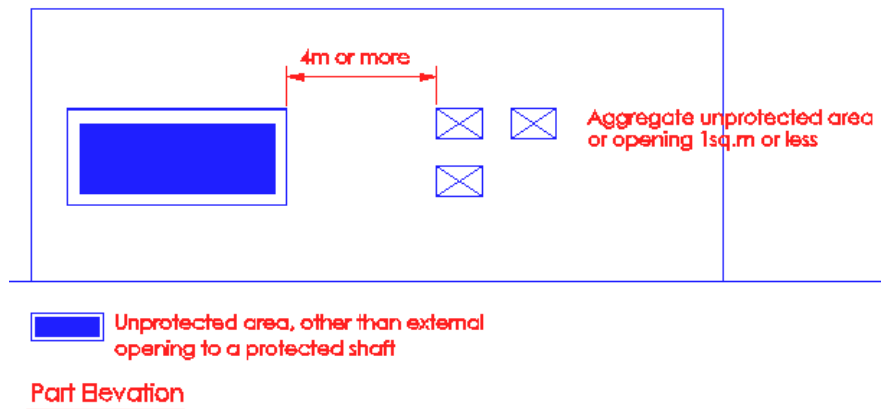
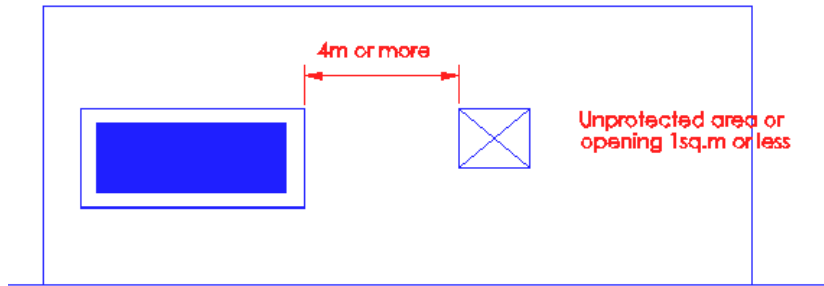

Diagram 2(b)(i) – Pt. I Appendix B

- (ii) Unprotected area or aggregate area not exceeding 1m² and not less than 4m from other unprotected area





 Unprotected area

Part Elevation

Diagram 2(b)(ii) – Pt. I Appendix B

(iii) Unprotected area in external wall of protected shaft

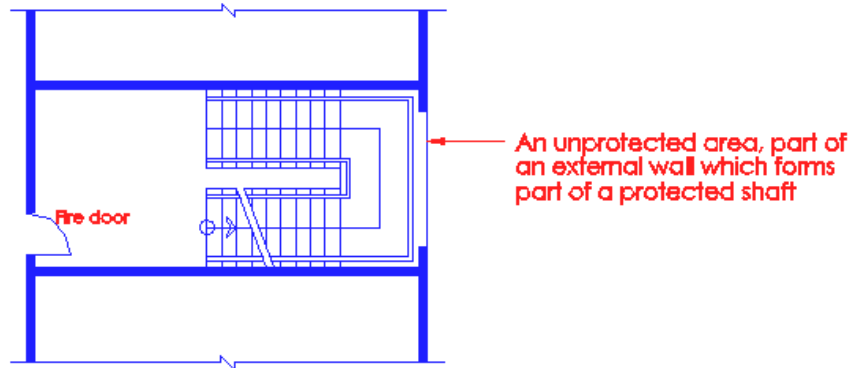

Plan

No account shall be taken of unprotected area in external wall of protected shaft

Diagram 2(b)(iii) – Pt. I Appendix B

(iv) Unprotected area above 28m of uncomparted building

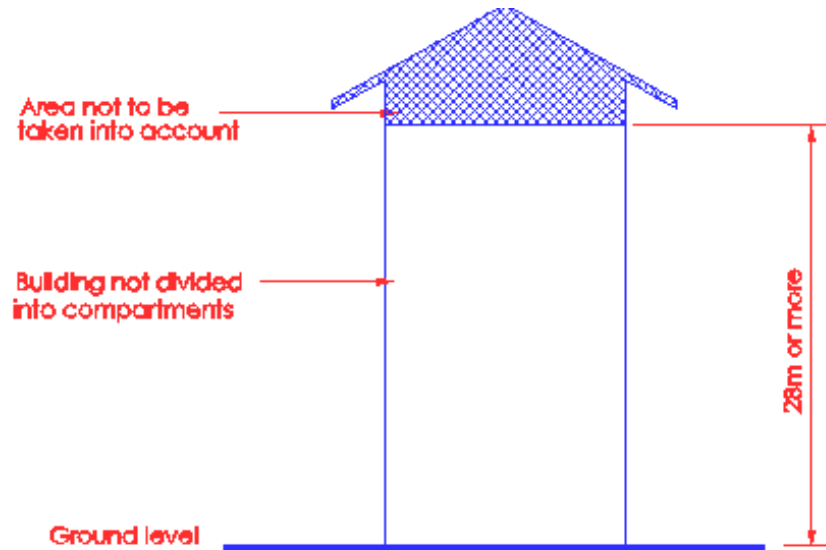

Section

No account shall be taken of any unprotected area 28m or more above the ground in the external wall of building not divided into compartment

Diagram 2(b)(iv) – Pt. I Appendix B

PART II

Rules of calculation by reference to an enclosing rectangle

3. The conditions of this Part of this Appendix shall be satisfied if a building or compartment is so situated that no point on the relevant boundary is either between relevant plane of reference and the side of the building or compartment or at a distance from the relevant plane of reference which is less than the distance specified in the tables to Part of this Appendix, according to the purpose group of the building or compartment, the dimensions of the enclosing rectangle and the unprotected percentage.

4. For the purpose of this Part of this Appendix:

“relevant boundary” means as defined in Cl.1.2.52 and for the purpose of this calculation is either parallel to the side of the building under consideration or at an angle of not more than 80° with that side;

“plane of reference” means any vertical plane which touches the side or some part of the side of a building or compartment but which (however far extended) does not pass within the structure of such building or compartment (and for this purpose, any balcony, coping or similar projection shall be deemed not to be part either of that side or of the structure); and the relevant plane of reference shall in each case be taken as that most favourable in that respect to the person erecting the building;

“enclosing rectangle” means the smallest rectangle on the relevant plane of reference which would-

- (a) enclose all the outer edge of any unprotected area of the building or, if the building is divided into compartments, of the compartment (other than any of an unprotected area which is at an angle of more than 80° to the plane of reference the outer edges being for this purpose projected on the plane of reference by line perpendicular to such plane:
- (b) have two horizontal sides: &
- (c) have height and width falling within those listed in the tables to this Part of this Appendix:

“unprotected percentage” means the percentage of the area of the enclosing rectangle which is equal to the aggregate areas taken into account in calculating the enclosing rectangle and as projected on it.

Determining the relevant boundaries

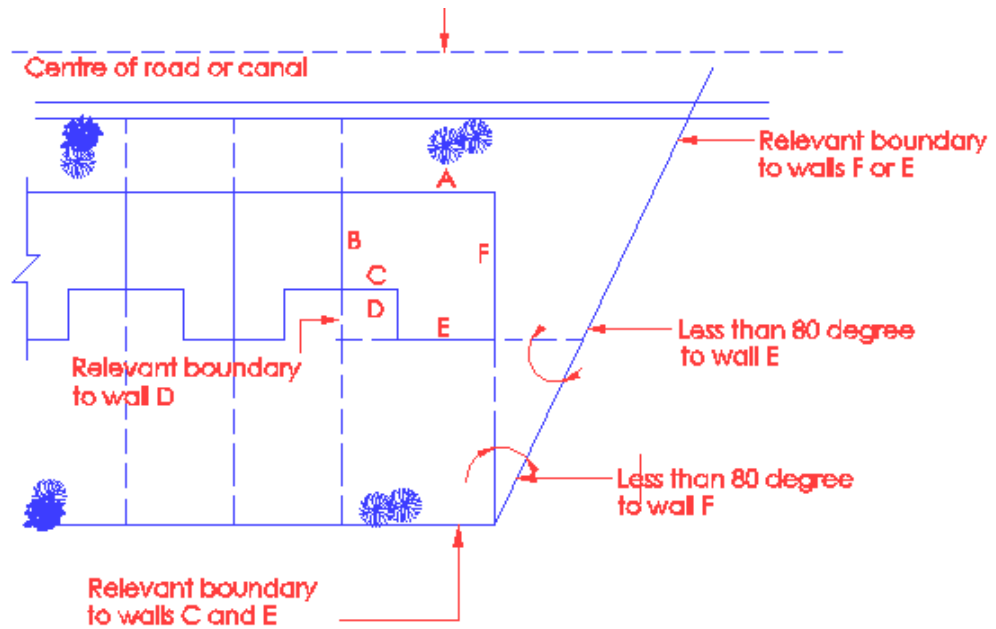

Diagram 4 – (1) Pt. II Appendix B

Relevant boundaries – where the side of a building is on the boundary, that is the 'relevant boundary'. Otherwise it is the actual boundary of the land either parallel to, or making an angle of not more than 80° with the face of the building in question. Note that a boundary can be relevant to more than one face. Where land abuts a road or canal the relevant boundary is taken as the centre of these. The points are illustrated in Cl.1.2.52 in Vol. 1 of the Handbook.

Distance between plane of reference and relevant boundary related to dimensions of enclosing rectangle will determine the max. percentage area permitted. Alternatively the total unprotected area in relation to the size of the enclosing rectangle will determine the min. distance from the boundary

Relevant boundary parallel to side or at an angle of not more than 80 degree to it

Plane of reference in a position most favourable to the person erecting the building, but it must touch some part of the side under consideration and must not pass through the building

Outer edges of unprotected areas projected perpendicularly to plane of reference

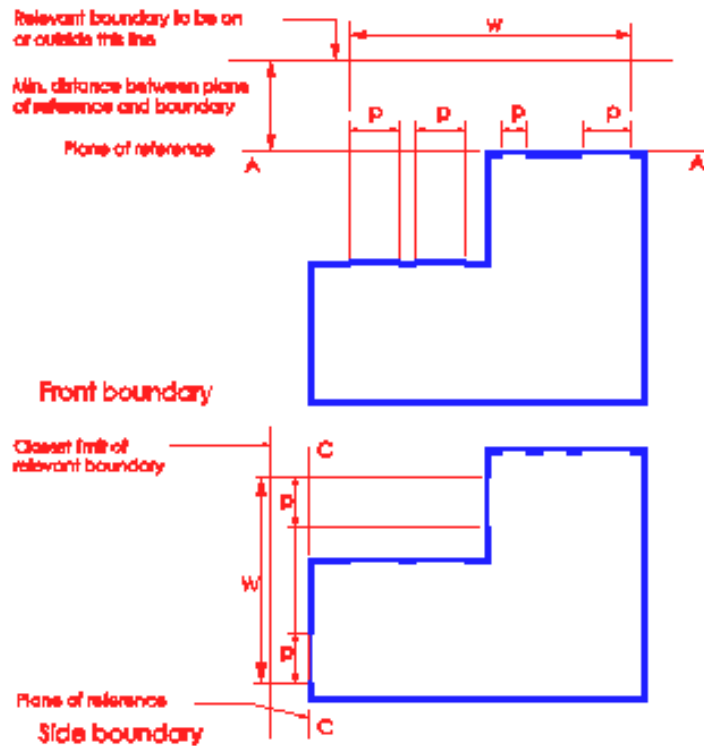
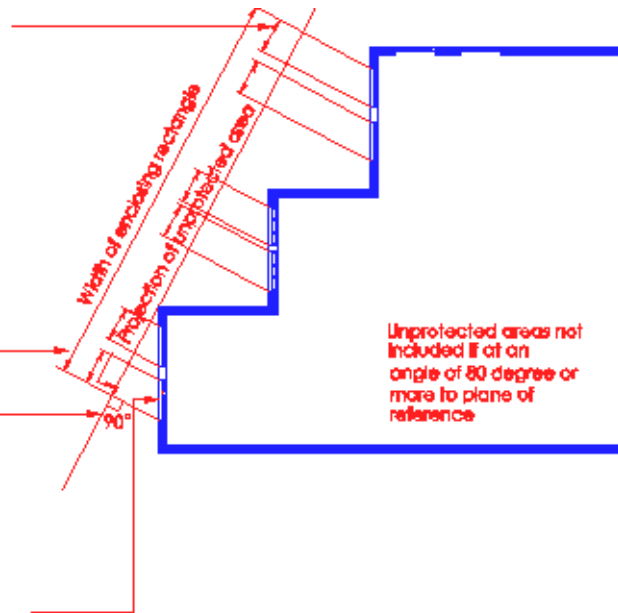

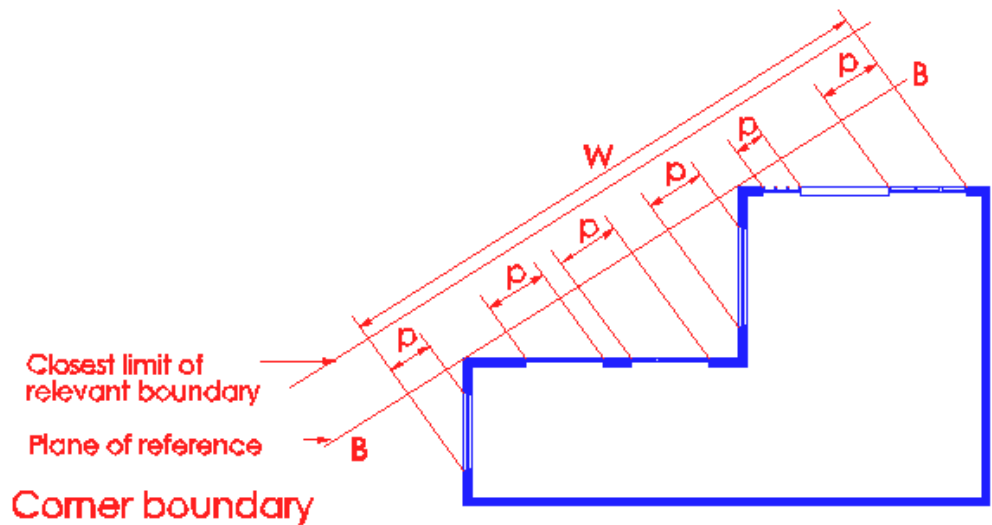

Diagram 4 – (2) Pt. II Appendix B

Plane of reference to more than one face of a building

Lines A – A, B – B & C – C represent the plane of reference.

Plane of reference – A plane of reference has to be established for each side of the building which faces a boundary. This is a vertical plane which touches, but does not pass through the building (except for such projections as bay windows, balconies, cornies etc), nor does it cross the boundary (known as the “relevant boundary”). It must not make an angle of more than 80° with the side of the building.

It will usually (but not always) be appropriate for it to be parallel to the boundary and in many cases it will coincide with the face of the building. On to this all the unprotected areas facing the boundary are projected at right angles, but excluding any that are set at an angle of more than 80° to the plane. It is quite possible for a plane of reference to take in more than one side of a building.

Enclosing rectangle

A rectangle is constructed on the plane of references so as to enclose the outer limits of all the unprotected areas on that side of the building or compartment. The enclosing rectangle is the smallest rectangle which would :

- (a) enclose the outer edges of any unprotected areas;
- (b) have two horizontal sides; and
- (c) have height and width falling within those listed in Tables 1 and 2

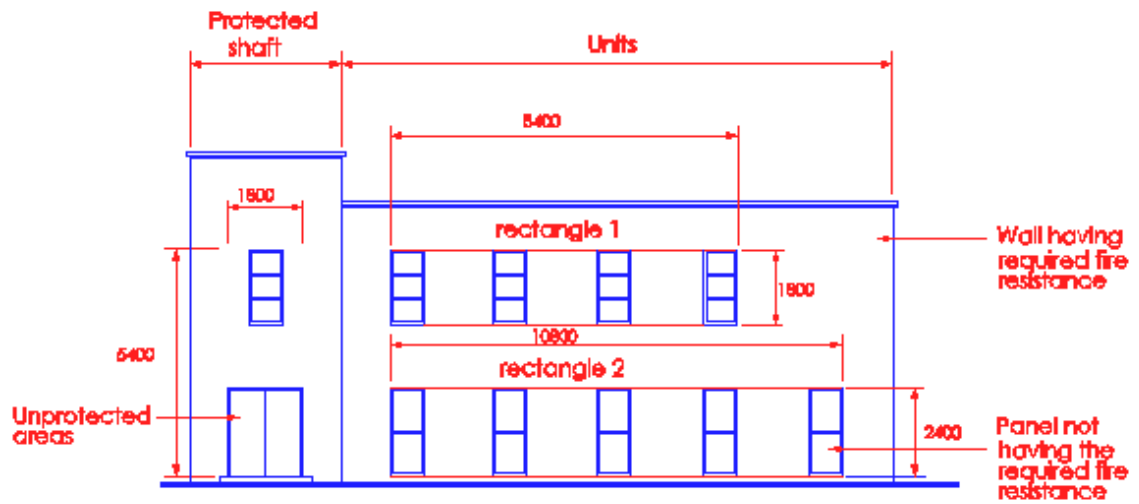

Unprotected areas and enclosing rectangles

Diagram 4 – (3) Pt.II Appendix B

Unprotected percentage

This is established by taking the aggregate area of all the unprotected areas (see diagram above) as percentage of the area of the enclosing rectangle.

Example on calculations on unprotected areas

A

Example on calculations of unprotected openings/separation distance requirements for apartment unit

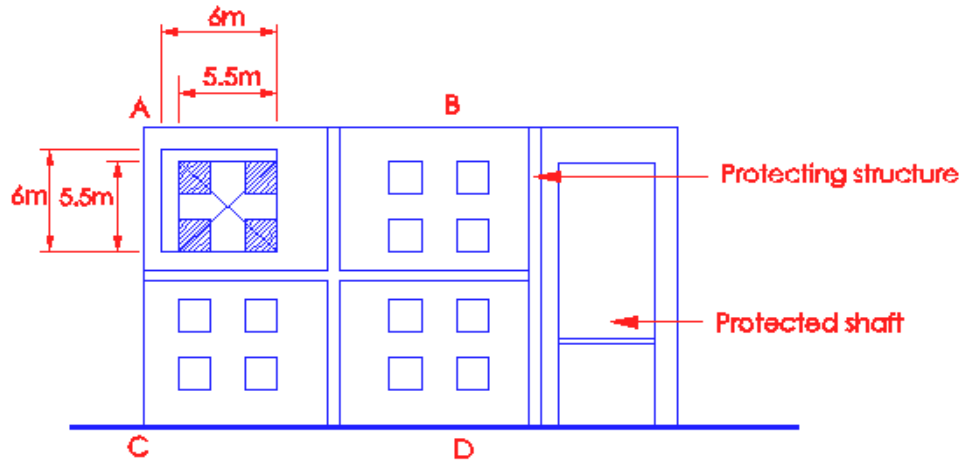

For apartment building, each unit is a compartment as shown in above diagram (compartments A, B, C and D). It is assumed that the relevant boundary is parallel with the face of the building. For calculating the unprotected areas, each compartment can be taken separately, usually the one with the most unprotected areas.

1. Assume rectangle (enclosing unprotected areas) = 5.5m x 5.5m
2. To use the nearest corresponding enclosing rectangle from Table 1, of Fire Code, enclosing rectangle = 6m x 6m = 36sq m
3. Assume unprotected areas = 14.4sq m
4. Unprotected percentage (unprotected areas as percentage of enclosing rectangle)
= 14.4sq.m as percentage of 36sq.m
= 46% use 40% column in Table 1
5. From table 1 distance from boundary = 2m (minimum)

Footnote: By interpolation between 40% and 50% column, the separation distance would be 2.25m, which is acceptable.

3.5.5 Reference to Part I - II of Appendix B

Any reference to Appendix B shall be construed as referring to the provisions of Part I of that Appendix together with the provisions of Part II.

(No illustration)

3.5.6 Buildings on land in common occupation

If two or more detached buildings are erected on land in common occupation, any external wall of any building so erected which faces an external wall of such other building, the relevant boundary shall be a notional boundary passing between those buildings and such boundary must be capable of being situated in such a position as to enable the external walls of those buildings to comply with the requirements of Cl. 3.5.3.

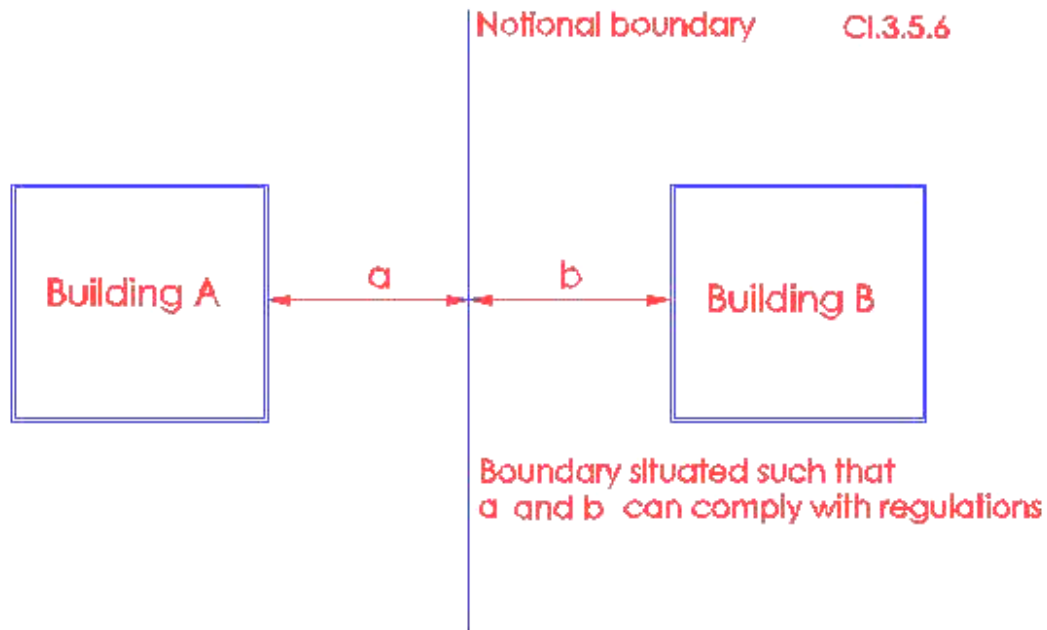

Diagram 3.5.6

- (a) It is necessary to assume a notional boundary when two or more detached buildings are erected on land in common occupation.
- (b) The notional boundary is taken to exist in space between the buildings and is positioned so that the external walls of building A and B facing the notional boundary comply with the separation distance requirement in accordance with Tables of Appendix B, based on the percentage of unprotected area and the purpose group of the compartment/floor.
- (c) Unprotected openings shall be assessed for each building separately. The separation distance between the two buildings shall be not less than the sum of the distance each building would require to a relevant boundary ie. "a" is equal to or greater than the separation distance to the boundary for building A and "b" is equal to or greater than the separation distance to the relevant boundary for building B.
- (d) The notional boundary can be shifted next to external wall of building A or B, if the external wall has no unprotected areas and is constructed of non-combustible materials having the requisite period of fire resistance rating as the elements of structure of the storey compartment.

3.5.7 Vertical fire spread

For high and low parts of different compartments of a building abutting each other, either one of the following requirements shall be complied with to prevent spread of fire from the roof close to and lower than the external of the higher part:

- (a) the roof over the lower part of the building shall be fire rated in accordance with the element of structure for minimum 1 hour for a distance of 5m measured horizontally from the external wall of the higher part of building; or
- (b) the external wall of the higher part of the building overlooking the roof below shall have the necessary fire resistance rating in accordance with the element of structures for minimum 1 hour for a vertical height of not less than 9m measured from the roof of the lower part of the building.

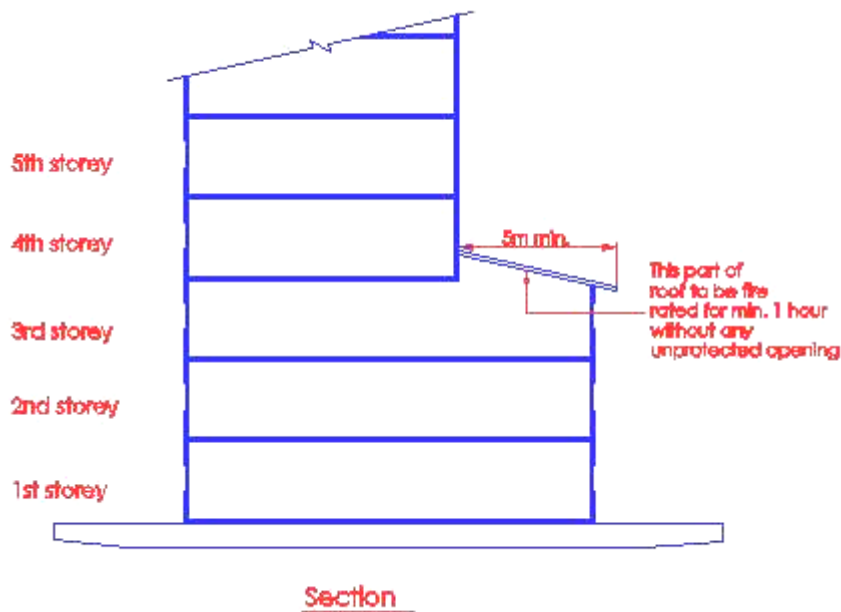

Diagram 3.5.7(a)

A fire occurring in the 3rd storey would spread vertically to 4th storey via the roof and windows. To prevent the fire spread vertically, the roof of 3rd storey should be fire rated for min. 1 hour for a distance of 5m measured horizontally from the external wall of 4th storey abutting the roof of 3rd storey.

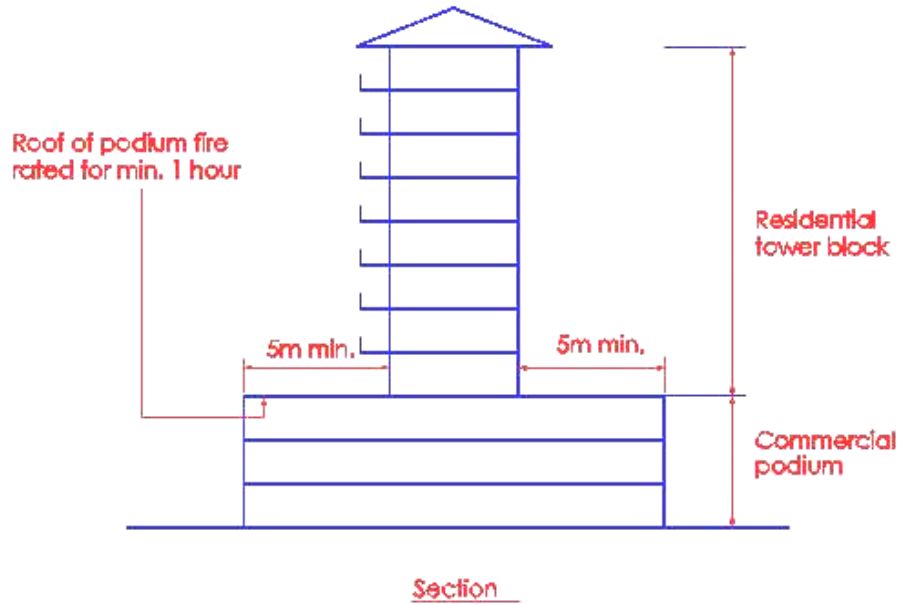

Diagram 3.5.7(b) - 1

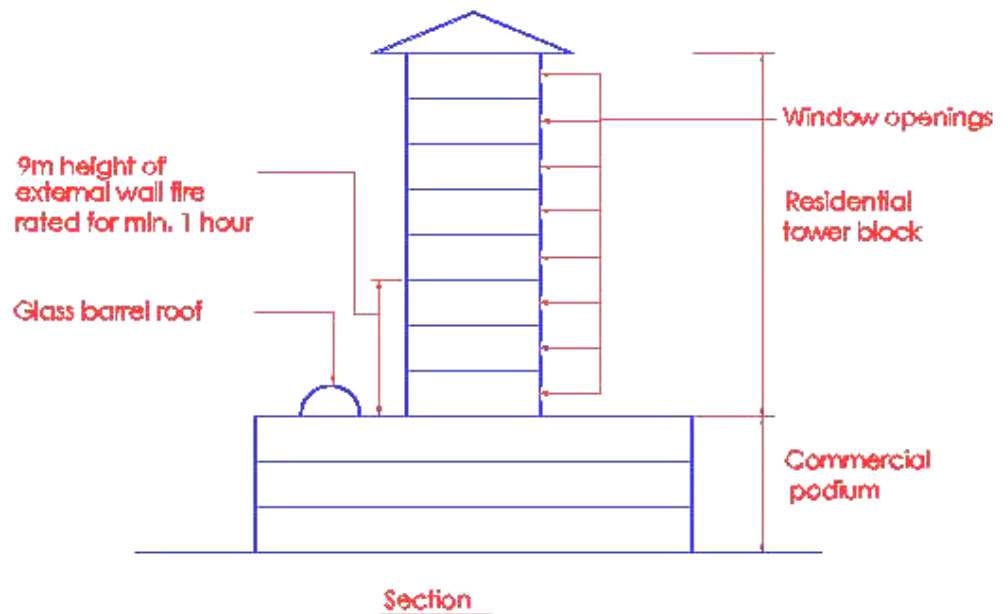

Diagram 3.5.7(b) - 2

Providing imperforate fire rated external wall is an alternative to fire rating the roof under subclause (a).

The above 2 diagrams show the 2 ways of preventing fire spread vertically from the lower floor to the upper floors.

- 3.5.7 (c) the above requirements shall not be applicable to buildings or lower parts of the building which are sprinkler protected, or old shophouses which are subject to URA's Conservation Programme or built before 1969 referred to under cl.1.1.1 and cl.1.1.2

3.6 SEPARATING WALLS

3.6.1 Every separating wall shall:

- (a) Form a complete vertical barrier in the same vertical plane through the full height between the buildings it separates, including roofs and basements and shall be imperforate except for provisions of openings permitted under Cl.3.6.2, and
- (b) Have the appropriate fire resistance to comply with the requirements of Cl.3.3, and
- (c) Be constructed of non-combustible materials, together with any beam and column which form part of the wall and any structure which it carries.
- (d) Not include glass fire resisting walls.

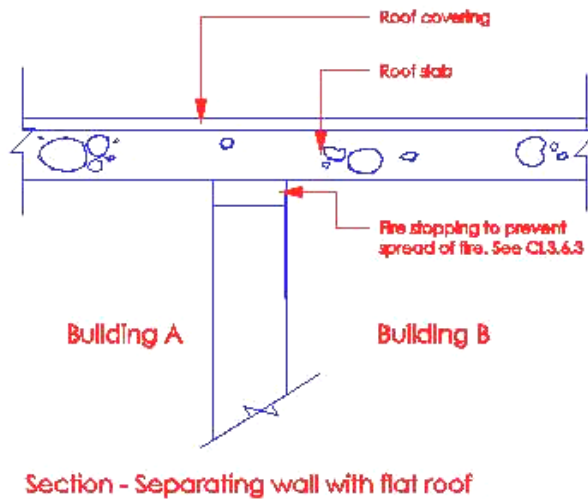

Diagram 3.6.1 - 1

Separating wall is the common wall that separates one unit from another. It is to prevent the spread of fire from unit to unit. The separating wall shall have the appropriate fire resistance rating as the elements of structure of the adjoining unit having the larger floor area or cubical extent as the case may be. Separating wall shall be imperforate, constructed of non-combustible materials and must have a fire resistance of not less than one hour. Openings may be formed for the passage of small pipes or where permitted as a means of escape under Cl.3.6.2. It shall not include fire resisting glass

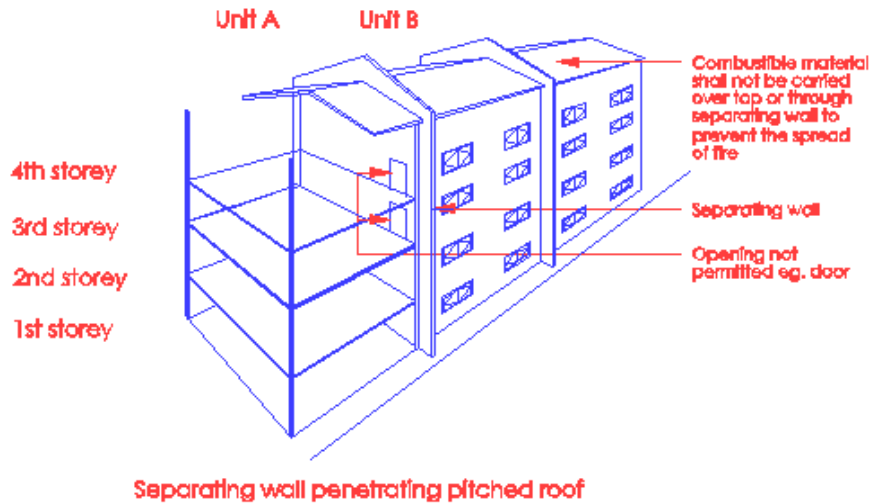

Diagram 3.6.1 – 2

With the separating wall brought above the roof, the concern of fire spread through cracks and gaps caused by poor bonding/fire stopping at wall/roof junction would be eliminated.

3.6.1 (e) Exception

Subclause (a) need not be applied to wall between car porches of buildings under purpose group I. For terrace-housing situation, this exception will not apply if the carporch is spanning from one side boundary to the other.

(No illustration)

3.6.2 A separating wall shall have no openings except for -

- (a) A door required to provide a means of escape in the event of a fire, having the same fire resistance as that required for the wall and complying with Cl. 3.9.2, or

- (b) A door provided for the purpose of public circulation and permitted by the Relevant Authority, having the same fire resistance as that required for the wall and complying with Cl. 3.9.2, or
- (c) Openings for the passage of a pipe complying with the relevant provisions of Cl. 3.9.3.

(No illustration)

Subclause (b) is not applicable to Purpose Group II

Door opening between 2 residential units is not acceptable, unless the units are owned by one owner and occupied by a single family. In such a case the door opening in the separating wall shall be used solely for providing communication between the units and shall not be taken as means of escape during fire emergency. The owner is to furnish an undertaking to FSSD that should one of the units be sold, the door opening in the separating wall shall be bricked-up to have the necessary fire resistance as the adjoining wall.

3.6.3 Separating wall - roof junction

A separating wall shall be either carried up to form a close joint with the underside of a pitched roof of non-combustible covering or carried up above the level of such roof covering. The junctions between such separating wall and roof shall be properly fire-stopped so as not to render ineffective the resistance of such separating to the effects of the spread of fire.

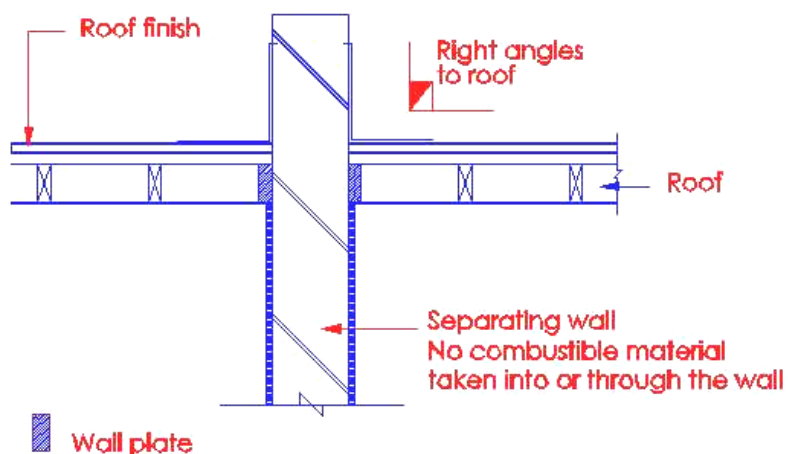

Diagram 3.6.3

3.6.4 If any external wall is carried across the end of a separating wall, such external wall and separating wall shall be bonded together or the junction of such walls shall be fire-stopped to comply with the requirements of Cl.3.12

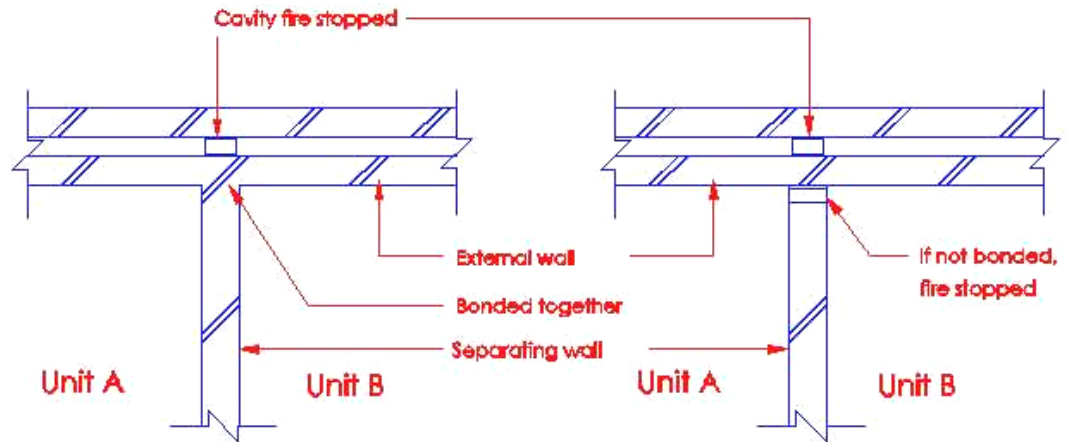

Diagram 3.6.4

3.6.5 Prohibition of combustible materials in separating walls

No combustible material shall be built into, carried through or carried across the ends of or carried over the top of separating walls in such a way as to render ineffective such separating walls to the effects of the spread of fire.

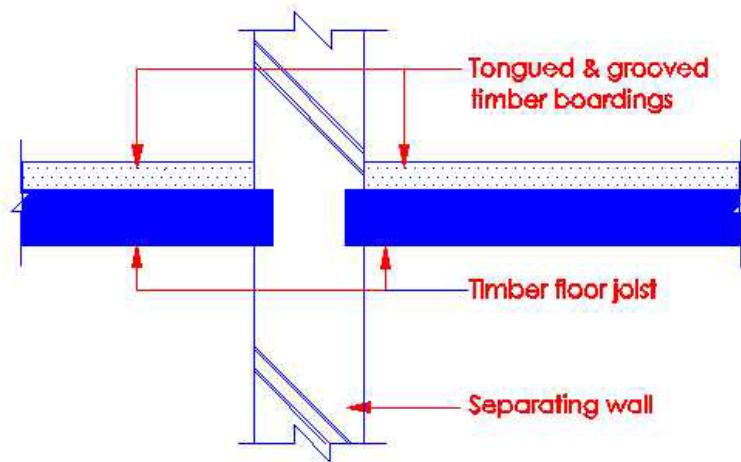

Diagram 3.6.5 - 1

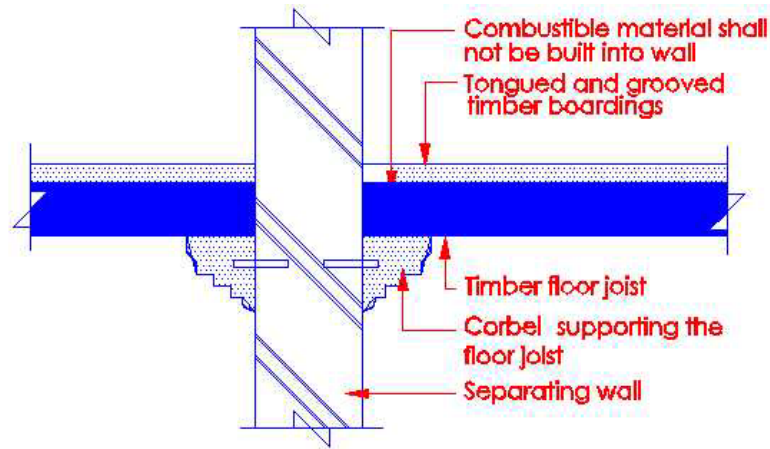

Diagram 3.6.5 – 2

Combustible materials built into separating wall would weaken the fire resistance integrity of the wall. Separating wall must be constructed of wholly non-combustible materials, including the beam, column or other structure carrying the wall. Exception is allowed for internal linings under Cl.3.13. However, for building under conservation, it would be acceptable if the original method of construction of floor is required to be retained.

3.7 COMPARTMENT WALLS AND COMPARTMENT FLOORS

3.7.1 Requirements of compartment walls and compartment floors

Every compartment wall or compartment floor shall be required to -

- (a) Form a complete barrier to fire between the compartments it separates, and
- (b) Have the appropriate fire resistance to comply with the requirements of Cl.3.3, and
- (c) Be constructed of non-combustible materials (together with any beam or column which forms part of the wall or floor and any structure which it carries), and
- (d) Have no fire resisting glass forming part of it unless permitted by the Relevant Authority.

(No illustration)

Compartment walls and floors are to be totally imperforate except for the following permitted openings :

- (a) doors
- (b) protected shafts
- (c) ventilation ducts
- (d) pipes
- (e) chutes eg. refuse, linen

Compartment walls and floors are to be constructed wholly of non-combustible materials, including any beam or column which forms part of the wall or floor and any structure which it carries. The walls and floors shall be constructed to have the necessary fire resistance of min. 1 hour to comply with the requirements of Cl.3.3. See Cl.3.2.5 on the provision of compartment walls and floors to apartment/maisonette unit. Provision of fire resisting glass in compartment wall or floor separating residential units is not allowed.

3.7.2 Openings in compartment wall or compartment floor

A compartment wall or compartment floor shall have no openings in it, except for -

- (a) A door which has the same fire resistance rating as the compartment wall and complies with the relevant requirements of Cl. 3.4, unless permitted by other provisions of the Code, or
- (b) A protected shaft which complies with the requirements of Cl. 3.8, or
- (c) The passage of a pipe or ventilation duct, such openings in the compartment wall or compartment floor shall be protected to comply with the relevant provisions of Cl. 3.9.

It is a common practice to provide ½ hour fire resistance entrance door to flat or maisonette from common space, eg lobby. The fundamental reasons are that entrance doors are subject to normal everyday usage and that it is generally accepted that no combustible materials would be placed behind the doors. In other situation, the door within compartment wall shall have the same fire resistance as the compartment wall. This is applicable to trap doors in floors.

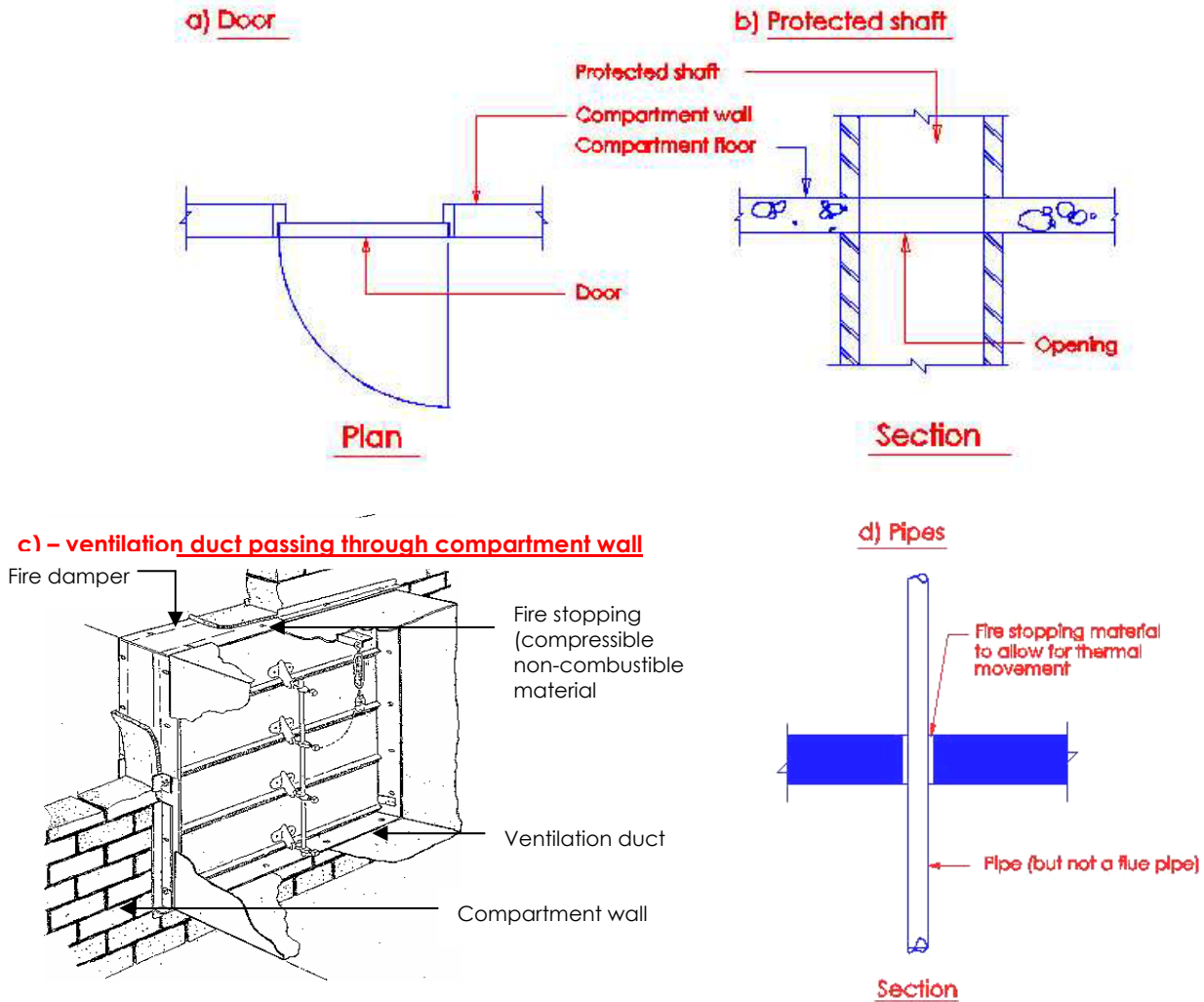

Compartment walls and floors are required to be totally imperforate except for the above mentioned openings to permit movement of people, air, services etc in the building.

3.7.3 (a) Junction with other structures

Where a compartment wall or compartment floor forms a junction with any structure comprising any other compartment wall, or any external wall, separating wall or structure enclosing a protected shaft, such structures shall be bonded together at the junctions or the junctions shall be fire-stopped to comply with the requirements of Cl. 3.12.

See subclause 3.6.4 (Separating wall - external wall function)

(b) Opening in curtain walling

The opening occurring at the junction between the edge of a structural floor and the curtain walling shall be sealed to prevent the spread of smoke and flame from the lower floor to the upper floor via the opening. Materials to be used for sealing the opening shall have the requisite fire resistance rating as the elements of structure.

See subclause 3.6.4 (Separating wall – external wall function)

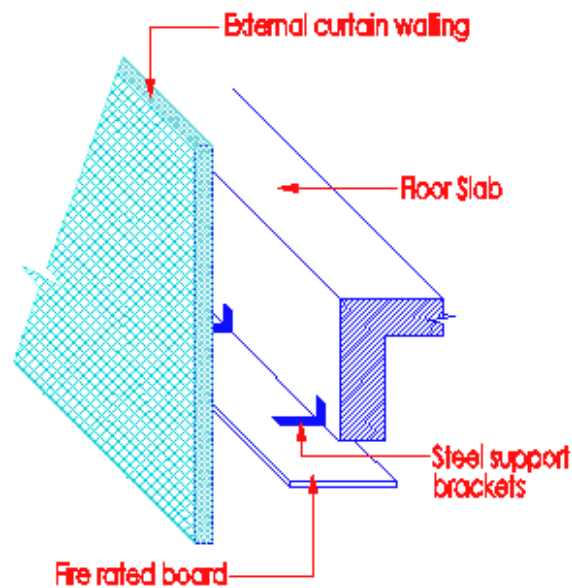

Diagram 3.7.3

3.7.4 Compartment – roof junctions

Where a compartment wall forms a junction with a roof, such compartment wall shall be carried up to form a close joint with the underside of the roof and shall be properly fire-stopped or shall be carried up above the level of the roof covering and the junction between such compartment wall and roof shall be properly fire – stopped so as not to render ineffective the resistance of such compartment wall to the effects of the spread of fire.

See subclause 3.6.3 (Separating wall – roof function)

3.7.5 Prohibition of combustible materials

No combustible material shall be built into, carried through or carried across the ends of any compartment wall or compartment floor or carried over the top of any compartment wall in such a manner as to render ineffective the resistance of such wall or floor to the effects of the spread of fire.

See subclause 3.6.5 (Prohibition of combustible material in separating wall)

3.7.6 Non-combustibility of compartment walls or floors

Every compartment wall or compartment floor shall be constructed of non-combustible materials, unless permitted by the Relevant Authority.

Construction of compartment walls and floors is to be entirely of non-combustible material, except for compartment walls or floors in buildings which are required to be retained by URA under the conservation programme. There are also certain other exceptions :

- a) floor finishes*
- b) wall or ceiling linings complying with Cl.3.13*
- c) suspended ceilings under Cl.3.3.6*

Any structural members carrying compartment walls or floors must also comply with the requirement of non-combustibility. Apart from the contribution made by suspended ceilings under CL.3.3.6, the fire resistance of the structural members must be attained without assistance from any combustible material (with the exception of buildings designated for conservation).

3.8 PROTECTED SHAFTS

3.8.1 Purpose of protected shaft

A protected shaft shall not be used for any purpose additional to those given as defined under Cl. 1.2.47.

All services such as, pipe/duct installation should not be located inside protected staircase. Likewise, no washroom is allowed to be located inside protected staircase.

(No illustration)

The purposes of providing protected shaft are to delay or prevent the spread of fire between compartments through which staircases or other shafts pass directly and to enable people or things or air to pass between compartments. "Protected Shafts" include stairways, lift shafts, chutes, ducts or any other shaft enabling movement of people, goods, air, pipes, etc.

Protecting structures shall be treated as elements of structure for the purpose of determining the period of fire resistance rating.

3.8.2 Requirements of protected shaft

Every protected shaft shall be required to –

- (a) Form a complete barrier to fire between the different compartments which the shaft connects, and
- (b) Have the appropriate fire resistance to comply with the requirements of Cl. 3.3, and
- (c) Be constructed of non-combustible material (together with any beam or column which forms part of the enclosure and any structure which carries it).

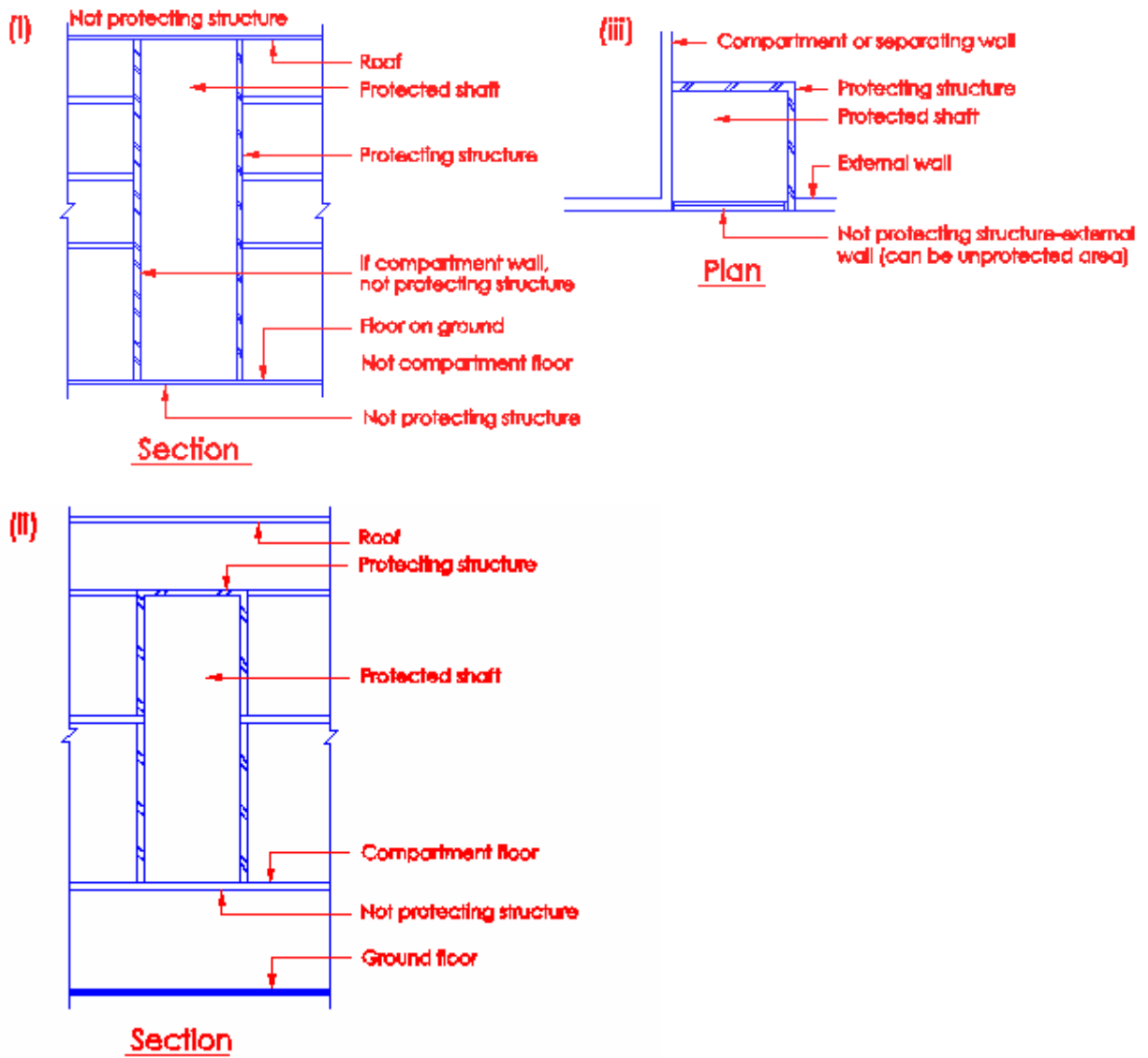

Diagram 3.8.2

See Cl.1.2.48 under Definition (Vol 1)

Where the protection afforded to a compartment is penetrated to allow the movement of people, goods or anything else between compartments by means of eg. a staircase, lift or duct, the protection to the compartment must not be lowered or diminished. This is achieved by enclosing the means of transportation from one compartment to another in a protected shaft which is so constructed that any penetration of the enclosures to the shaft poses no direct or indirect threat to the compartments connected by the shaft. Hence, the terms "protected shaft" and "protecting structure" for the structure enclosing such a shaft. The elements enclosing the shaft (unless formed by adjacent external walls) are compartment walls and floors.

Figure (iii) of the above diagram illustrates a shaft which is enclosed by compartment or separating wall, external wall and internal walls called protecting structure. The fire resistance of the compartment or separating wall should be based on the size of the floor area or cubical extent of the adjoining larger compartment and shall not be less than 1 hour

The fire resistance of the external wall would be determined by the separation distance requirements under Cl.3.5. The external wall is not a protecting structure and could be fully unprotected areas having no fire resistance. The remaining 2 walls of the shaft are protecting structure which must be imperforate except for certain permitted openings, eg. inspection doors which need to have fire resistance equivalent to half that of the protecting structure. All protecting structure shall be constructed of non-combustible material except for surface linings which shall comply with Cl.3.13. The fire resistance of the protecting structures shall be that for the elements of structure of the building.

3.8.3 Openings in protected shaft

A protected shaft shall have no openings in its enclosure, except -

- (a) In the case of any part of the enclosure which is formed by a separating wall, any opening which complies with the requirements of Cl. 3.6 for separating walls, or
- (b) In the case of any part of the enclosure which is formed by a compartment wall or a compartment floor, any opening which complies with the requirements of Cl. 3.7 for compartment wall or compartment floor, or
- (c) In the case of any part of the enclosure which is formed by the protecting structure -
 - (i) a door which has the appropriate fire resistance to comply with the requirements of Cl. 3.4 for test of fire resistance, or otherwise permitted by provision of Cl. 3.8.6, or

- (ii) the passage of a pipe, excluding protecting structure to exit staircase and exit passageway, or
- (iii) inlets to and outlets from and opening for the duct, if the shaft contains or serves as a ventilation duct,

such openings in the protected shaft shall be protected to comply with the relevant provisions of Cl. 3.9 for protection of openings.

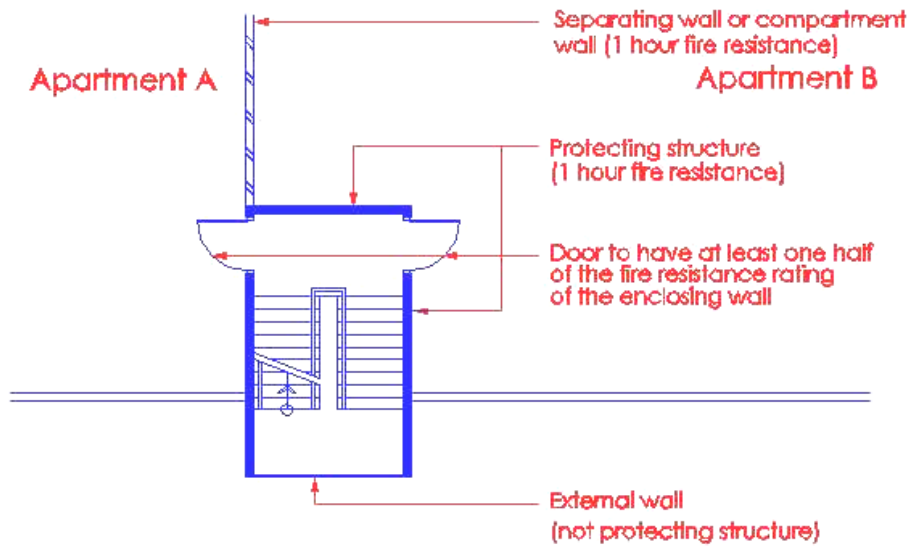

Diagram 3.8.3 (a)

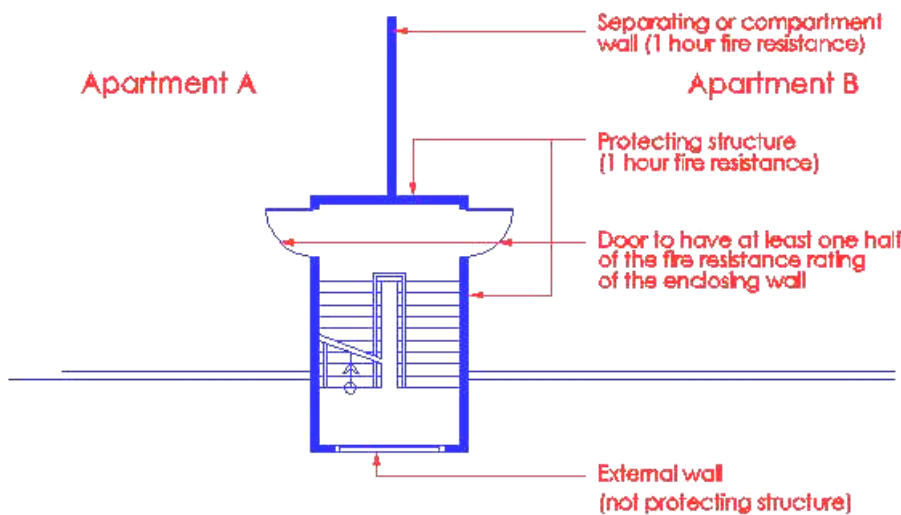

Diagram 3.8.3 (b)

Protected shaft bounded on three sides by protecting structure and fourth side by an external wall. Permitted opening to each unit shall be protected by a door of at least one half of the fire resistance rating of the enclosing wall, or half an hour, whichever is the greater. The aggregate fire resistance of the 2 doors shall not be less than the fire resistance of the protecting structure.

Permitted openings in protected shaft

a) Shaft containing ventilation duct pipes

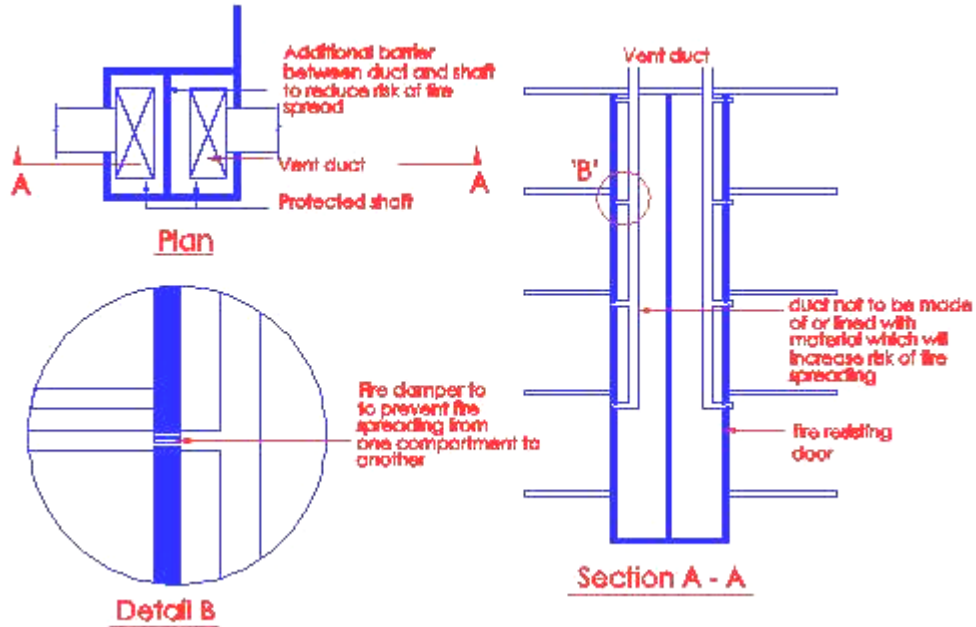

Diagram 3.8.3(c) - 1

b) Shaft containing gas pipe

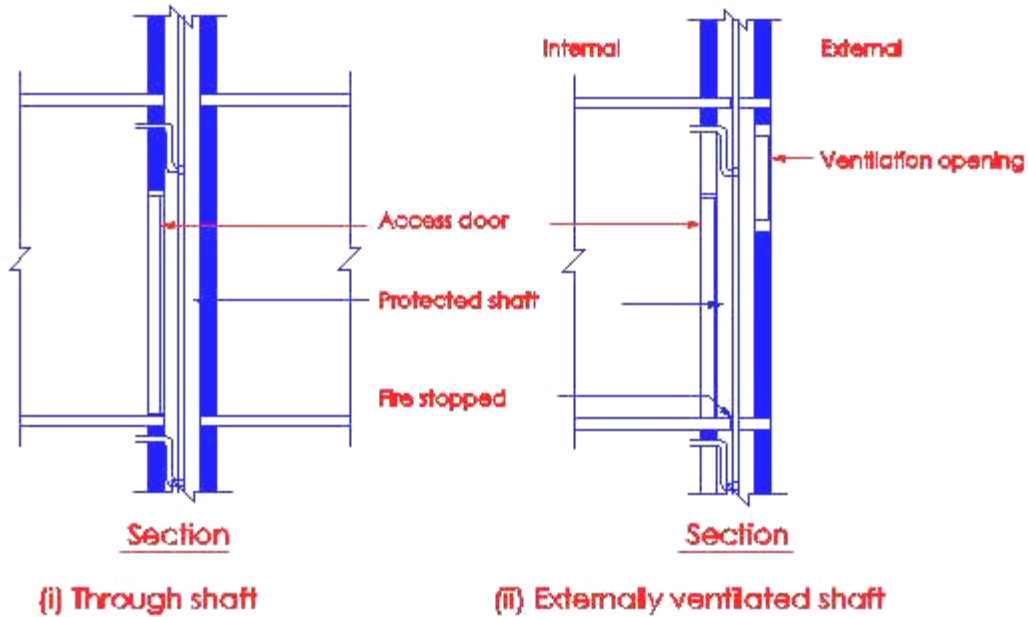
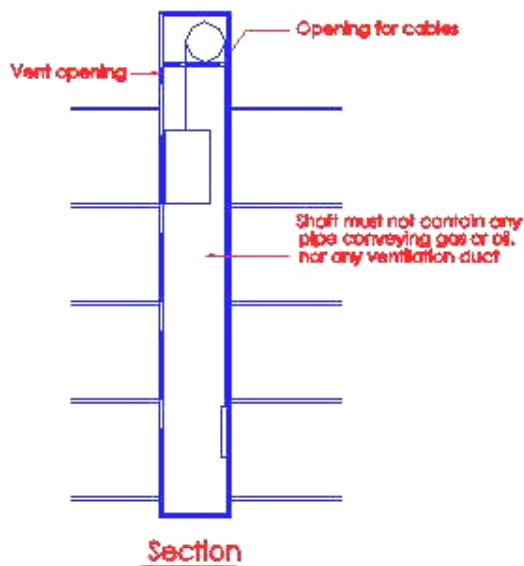

Diagram 3.8.3(c) – 2

c) Shaft containing a lift



d) Shaft containing exit staircase

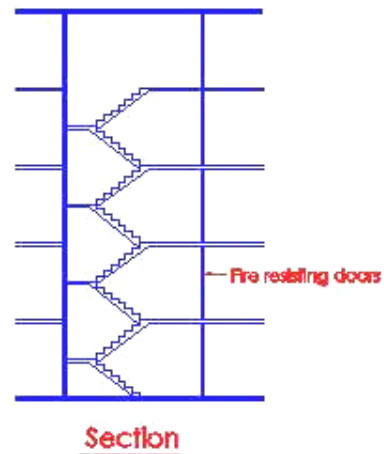

Diagram 3.8.3(c) – 3

Fire resisting doors to comply with Cl.3.9.2 and shall have ½ hour fire resistance or half the resistance of the enclosing walls, whichever is the greater

- 1) Any opening in compartment floor/wall would constitute a break in compartmentation. Therefore even small service pipes, strictly speaking must be enclosed in protected shaft.

- 2) However, clause 3.9 allows pipe size not greater than those sizes provided in Table 3.9A to be unprotected, provided the pipes are to be spaced at min. 50mm apart or half the diameter of the larger pipe, whichever is larger. This is to avoid clustering of pipes which would weaken the compartment floor or wall
- 3) Openings in compartment floors to accommodate staircases, lifts and services form a vertical shaft which can become a ready means of passage of fire from one storey to another, accentuated by the flue effect created by a fire.
- 4) Hence, protected shafts are needed to maintain the overall fire integrity of the building. However, these shafts need to have door openings for movement of people, eg. staircase, lifts and maintenance purposes in the case of shafts containing services. All the door openings to protected shaft are considered the sources of weakness in the integrity of the shafts and they must be protected.

Door openings

- 5) Doors in protected shaft must have at least ½ hour fire resistance rating or half the fire resistance of the protecting structure whichever is greater.
- 6) Such a relaxation from the full standard of fire integrity is reasonable as it is expected that combustible materials would not be placed next to the door and that a fire has to break into the shaft and break out again at the upper level. Also if the top of the shaft is adequately ventilated, the tendency for lateral spread is considerably reduced.
- 7) The primary purpose of protecting structure is to provide the compartmentation between floors. As such the structure shall have full fire resistance as the elements of structure. The relaxation on fire resistance accorded to fire doors shall not be extended to the protecting structure ie. halve the fire resistance of the elements of structure. The main reason is that by halving the fire resistance of protecting structure, the threat of failure and collapse of the enclosing walls would be greater in times of fire emergency and should the walls collapse, large opening would be created in the shaft to permit the spread of fire and smoke, which is not acceptable. As to door openings in protected shaft, the eventual failure of the fire door is considered acceptable owing to the limited door opening size. See illustrations (c) and (d).

Ventilation ducts

- 8) Ventilation ducts are usually constructed of sheet metal, which do not have fire resistance and therefore should a fire occur, they will quickly distort and collapse leaving a hole in any wall through which they pass. Conversely, a fire occurring in the duct could also cause collapse.
- 9) Therefore, where the duct penetrates the protected shaft, a fire damper should be fitted at the opening of the protecting structure. The fire damper shall be capable of sealing the opening in the protecting structure and be installed independently of the duct trunking. In this way, the fire damper would not be affected by collapse of duct work and be able to maintain the fire integrity of the shaft. See illustration (a).

Pipes

- 10) Where pipes are contained within a protected shaft, the problem of maintaining the integrity of the fire compartment is made simple, irrespective whether the pipes are made of UPVC or combustible materials. However, for gas pipes or pipes containing combustible liquids, they shall be located in separate shafts.

- 11) The construction of gas pipes shaft is different from other shafts owing to the need to provide through or external ventilation. Gas pipe shaft shall comply fully with SS CP 51. See illustration (b).

General

- 12) In order to maintain the level of integrity of protected shafts, openings in protected shafts shall be restricted to the following :
- a) Openings for pipe
 - b) Door openings to lift shaft, staircase
 - c) Openings for ventilation ducts
 - d) Access openings for electrical cables shaft
 - e) Openings for chutes, linen or refuse.

3.8.4 Non-combustibility of protecting structures

Every protecting structure shall be constructed wholly of non-combustible materials except that floor, wall and ceiling finishes which do not contribute to the fire resistance of such protecting structure may not be required to comply with the requirements for non-combustibility.

(No illustration)

The requirement that all protecting structure shall be constructed of non-combustible materials is also spelled out under Cl.3.8.2. As to the provision of combustible finishes to floor, wall and ceiling, it must be observed that such provision will not be permitted inside protected shafts that are used for the passage of people such as exit staircases, exit passageways and smoke-stop lobbies under Cl.3.10.4 and Cl.3.13.6.

3.8.5 Ventilation of protected shaft

Ventilation of protected shaft shall comply with the following:

- (a) A protected shaft used for the passage of people, such as exit staircases, shall be ventilated to comply with the relevant provisions of the Code.
- (b) A protected shaft containing a pipe conveying gas shall be adequately ventilated directly to the outside air or other modes of ventilation allowed under SS CP 51.

(No illustration)

Protected shaft used for passage of people, such as exit staircases shall be provided with adequate natural ventilation by fixed openings in the external walls. Such openings shall have an area of not less than 10 per cent of the floor area per floor of the staircase. Alternatively, the staircase can be mechanically ventilated under Cl.2.3.3(f). However, for internal exit staircase serving more than 4 storeys, the supply air shall be mechanically conveyed via a vertical duct extending through the staircase height and discharging from outlets distributed at alternate floor. Where the internal exit staircase exceeds 24m in height without provision for natural ventilation, the staircase shall be pressurised in accordance with Cl.2.3.3(g).

The mechanical ventilation system to internal staircase serving more than 4 storey and the pressurization system to internal exit staircase exceeding 24m shall be connected to emergency power supply. In addition, a remote manual start-stop switch shall be made available to fire fighters at the fire command centre, or at the fire indicating board where there is no fire command centre. The start-stop switch provides the fire fighter a quick means to shut-off the fans should it be detected that smoke had been drawn into the staircase by the fresh air supply fan.

A protected shaft conveying piped flammable gas should be adequately ventilated directly to the outside air by ventilation openings at high and low level in the shaft or comply with the modes of ventilation allowed in CP51. All gas pipe installations shall be vetted and approved by acceptable organisation (example: Powergas) before any works can be carried out on site.

3.8.6 Doors in protecting structures

Any door fitted to an opening in protecting structure shall have fire resistance for not less than half the period required by other provisions of the Code for the protecting structure surrounding the opening.

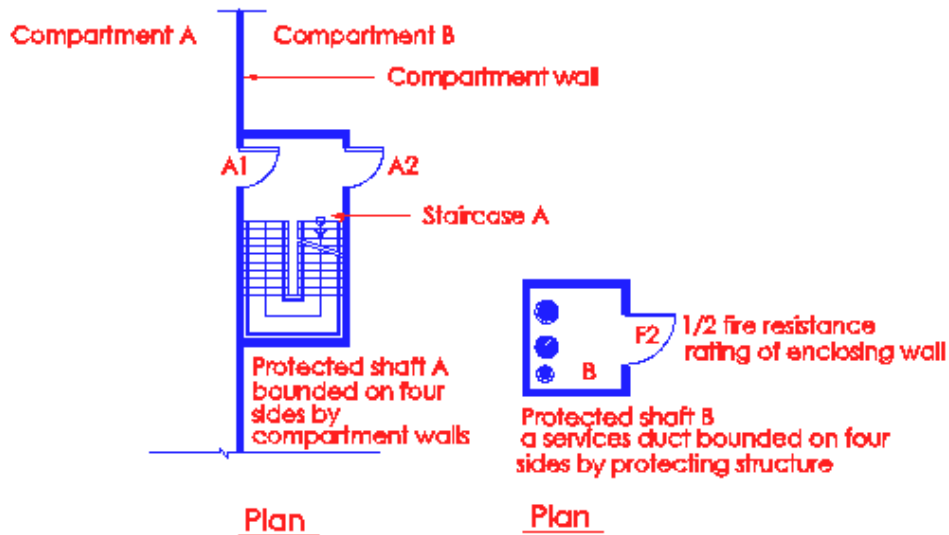

Diagram 3.8.6

Protected shaft A serves 2 compartments. Compartment A could be a common area eg. lounge and compartment B an apartment unit.

Door A1 is opening in the direction of exit travel, whereas door A2 is the entrance door of the apartment unit, which swings inward. The number of exit door openings in a protected shaft containing an exit staircase shall not exceed two per floor. This is to prevent additional openings from weakening the integrity of the protecting structure.

The aggregate fire resistance of door A1 and A2 shall not be less than the compartment wall or the protecting structures to the shaft. This is to ensure that the fire resistance between compartment A and B is not reduced at the door openings.

Door A1 can be held in the open position provided it is fitted with electro-magnetic or electro-mechanical device. See Cl.1.2.20 in Volume I.

All doors in shaft A & B shall have the fire resistance rating of half that of the enclosing protecting structures to the shafts, but shall never be less than half hour. See also Cl. 3.8.3 for further explanation.

Exception :

Any door fitted to an opening in protecting structure of a shaft containing services such as electrical cables, pipes, ducts would not need to have the fire resistance rating if the door is located along the wall facing the external corridor.

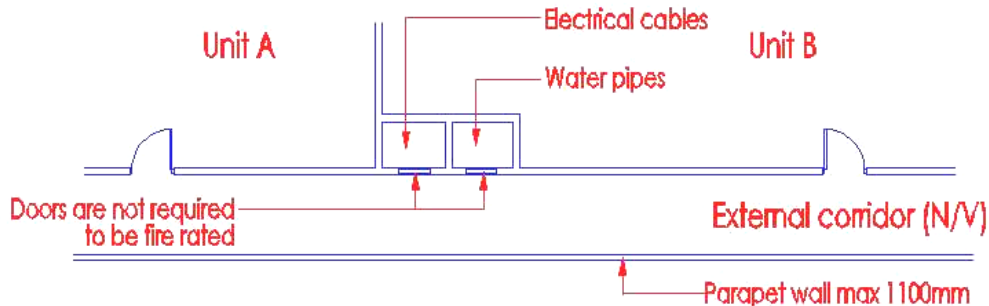

Diagram 3.8.6-2

3.8.7 Protected shaft containing exit staircase

A protected shaft which contains an exit staircase shall comply with the following:

- (a) It shall not contain any pipe conveying gas or combustible liquid.
- (b) It shall not contain any services that are not solely serving the same exit staircase except for:

- (i) cut-off sprinkler and pipe for that staircase; and
- (ii) UPVC or cast iron rain water downpipes serving the roof directly above the exit staircase, and not routed through anywhere outside the staircase.

3.8.7

(c) The protecting structure shall be constructed of masonry, or drywall. If drywall construction is used, the following conditions shall be complied with :

- (i) Drywall shall be non-combustible; and
- (ii) Drywall shall have fire resistance for not less than the relevant period specified in Table 3.3A having regard to the purpose group of the building of which it forms a part and the dimension specified in that Table; and
- (iii) Drywall shall meet the criteria, in terms of impact and deflection performance, when subject to the tests of BS 5588 Pt 5 Appendix A and BS 5234 Pt 2; and
- (iv) Drywall shall meet the criteria, in terms of water absorption and bending strength performance, when subject to the test of BS 1230 Pt 1 (for gypsum plaster board) or ISO 1896 (for calcium silicate or cement board); and
- (v) The building shall have at least two independent exit staircase shafts (scissors staircases are considered as single shaft).

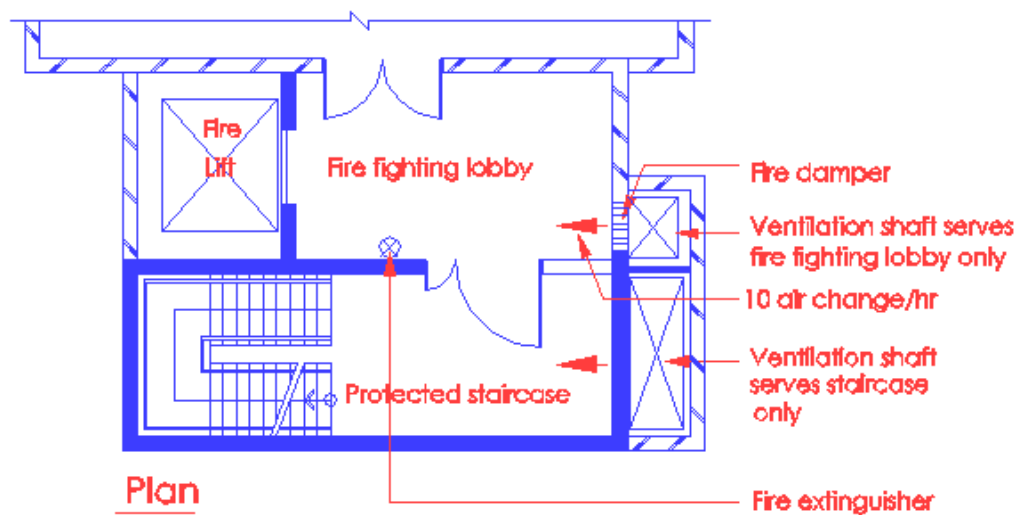

An exit staircase designated as fire fighting staircase in a building which exceeds 24m in habitable height has to be complemented by fire lift and fire fighting lobby. Separate ventilation shafts are required to be provided for the staircase and fire fighting lobby.

Exit staircases serving any building irrespective of the height, shall be devoid of combustible wall, floor and ceiling finishes. Building services which are not solely serving the exit staircase shall not be allowed to be routed through or inside the staircase. This is to prevent any possibilities of a fire occurring inside the staircase and the spread of fire into the staircase via the services such as electrical cables, ducts, combustible pipes, etc. Clause 6.2.2 of the Fire Code allows vertical stack of rising main and landing valve to be located inside the staircase as a last resort where smoke-stop lobby and common area outside the staircase are not available. Clause 2.4.3 of SS CP 10 allows sub-alarm panels to be located in the exit staircase provided there is no fire lift lobby or smoke-stop lobby in the building. The fire alarm cables shall be in metal conduit or trunking. This relaxation shall not apply to buildings which are more than 4 storeys in height where provision of smoke-stop lobby is a requirement.

The exit staircases are the means of escape in fire emergencies. All occupants must use the staircases to evacuate safely from any storey level to the final exits at ground level. The time taken to descend a staircase in a high-rise buildings could be more than an hour. With the staircase fully packed with evacuating occupants during an emergency, the staircase must be maintained safe from smoke, heat and fire throughout the fire resistance period of the enclosing protecting structures to the staircase. An exception is allowed under Cl.3.8.9(d) for maximum 4 storey residential building.

3.8.8 Lift shaft

A protected shaft which contains a lift shall comply with the following:

- (a) It shall not contain any pipe conveying gas or combustible liquid, other than those in the mechanism of a hydraulic lift.
- (b) The protecting structure shall be constructed of masonry, or drywall. If drywall construction is used, the following conditions shall be complied with :
 - (i) Drywall shall be non-combustible; and
 - (ii) Drywall shall have fire resistance for not less than the relevant period specified in Table 3.3A having regard to the purpose group of the building of which it forms a part and the dimension specified in that Table; and

- (iii) Drywall shall meet the criteria, in terms of impact and deflection performance, when subject to the tests of BS 5588 Pt 5 Appendix A and BS 5234 Pt 2; and
- (iv) Drywall shall meet the criteria, in terms of water absorption and bending strength performance, when subject to the test of BS 1230 Pt 1 (for gypsum plaster board) or ISO 1896 (for calcium silicate or cement board); and
- (v) Drywall shall meet the criteria of Cyclic Loading and Dynamic test as specified under Cl. 3.3 of Building Code of Australia Specification C 1.8.

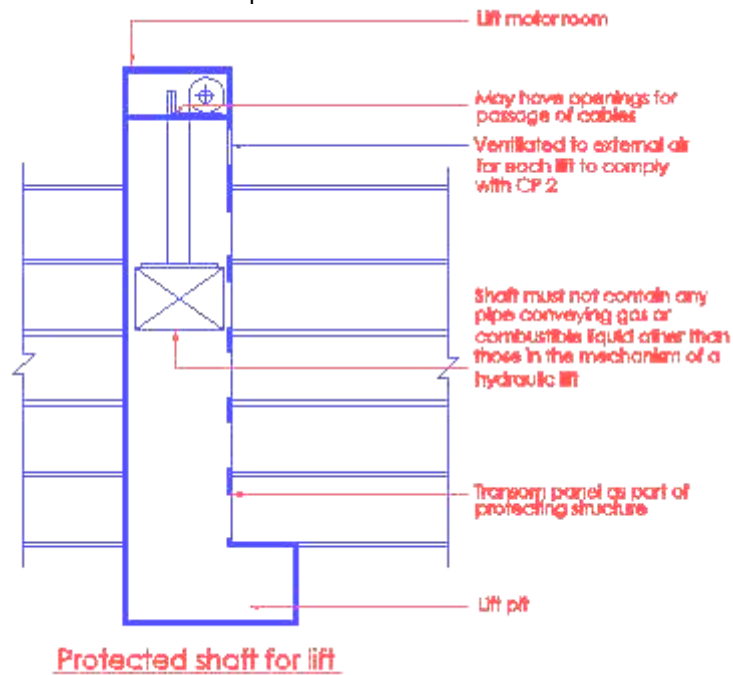

Diagram 3.8.8(a) & (b)-1

Lift shaft which is not located at the edge of atrium floors or at the external wall outside the building shall be constructed of masonry.

Sub-clause (a) above specifically permits combustible liquid in the mechanism of hydraulic lift. The liquid is concealed in vessels and forms part of the mechanical system to permit the homing of the lift during an emergency. The liquid has a high flash point of over 400°C.

- 3.8.8 (c) Where a lift is either located at the edge of atrium floors or at the external wall and outside the building, the lift shall be considered as not enclosed within a protected shaft.

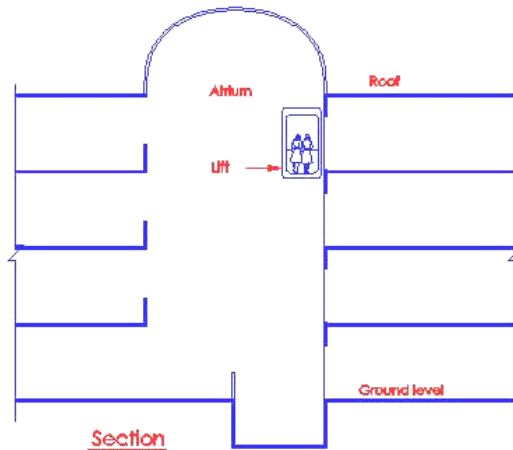

Diagram 3.8.8(c) - 1

In the above diagram the lift is unenclosed, being located within the atrium void. There is no penetration of any compartment floor and smoke migration caused by the 'piston-effect' of lift movement is no longer a concern. Smoke from a fire in any occupancy floor will flow from the ceiling layer into the atrium void where it will tend to rise upwards due to its natural buoyancy. A smoke control system would eventually extract the smoke out of the building

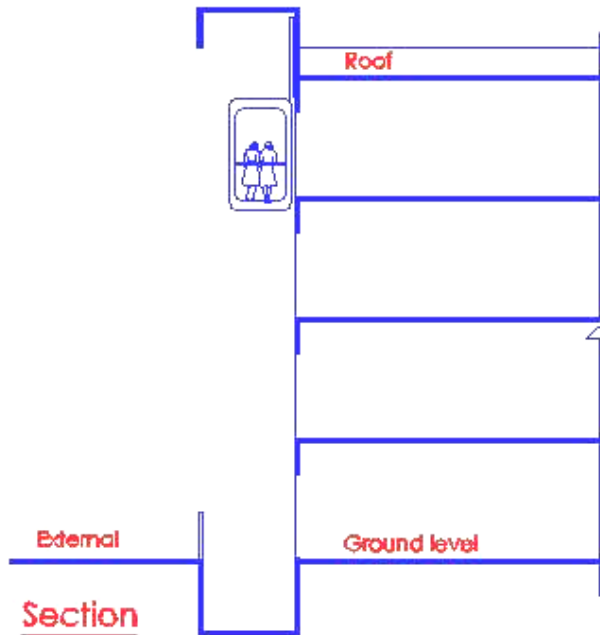

Diagram 3.8.8(c) - 2

The lift is sited outside the external wall of the building. There is no concern of smoke and heat being transferred from floor to floor. Hence it is not required to be enclosed in a protected shaft. This type of lift is commonly known as 'bubble lift' or 'sky lift'.

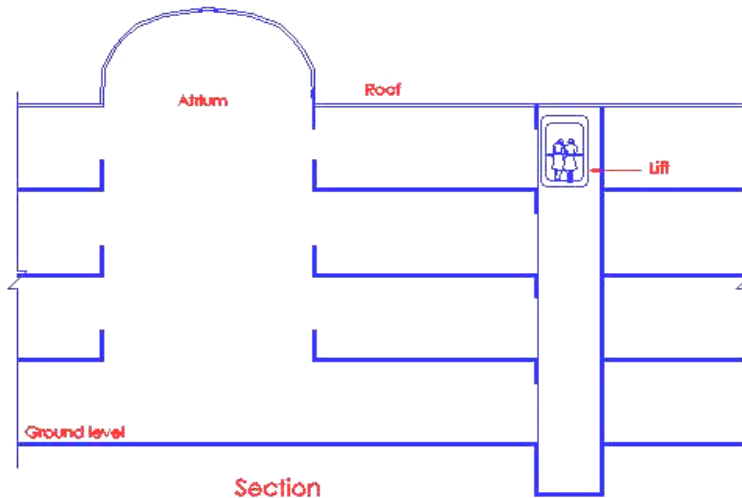

Diagram 3.8.8(c) – 3

The above diagram shows that the lift is located away from the atrium void. As the lift punctures through the compartment floors, it must be enclosed in a protected shaft to prevent the spread of smoke and heat from floor to floor.

- (d) The protected shaft shall be vented in accordance with SSCP 2 Code of Practice for Installation, Operation and Maintenance of Electric Passenger and Goods Lifts. The vents shall be so arranged as to induce exhaust ventilation of the shaft. Where vents could not be provided because of the location of the lift shaft, fire rated ventilation duct serving as ventilation of the shaft may be provided instead. If the duct is not to be fire rated, fire dampers shall be provided to the duct at the wall of the lift shaft, provided such relaxation shall not apply to shaft containing fire lift.

- 3.8.8 (e) Openings may be permitted for the passage of lift cables into the lift motor room and if the lift motor room is at the bottom of the shaft, the opening shall be as small as possible.

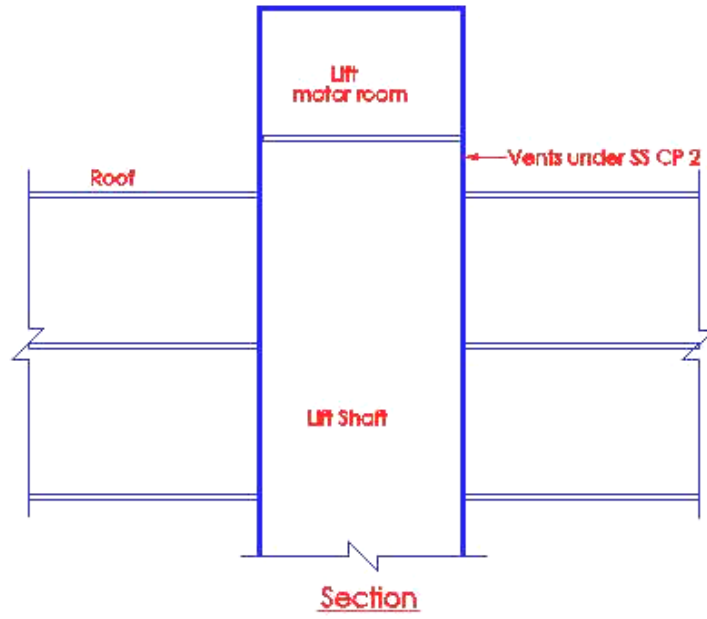

Diagram 3.8.8(e) - 1

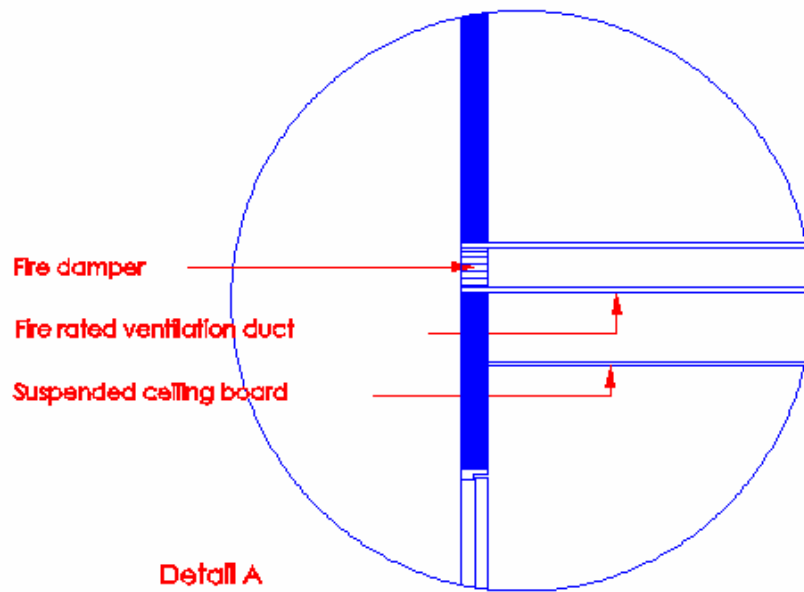
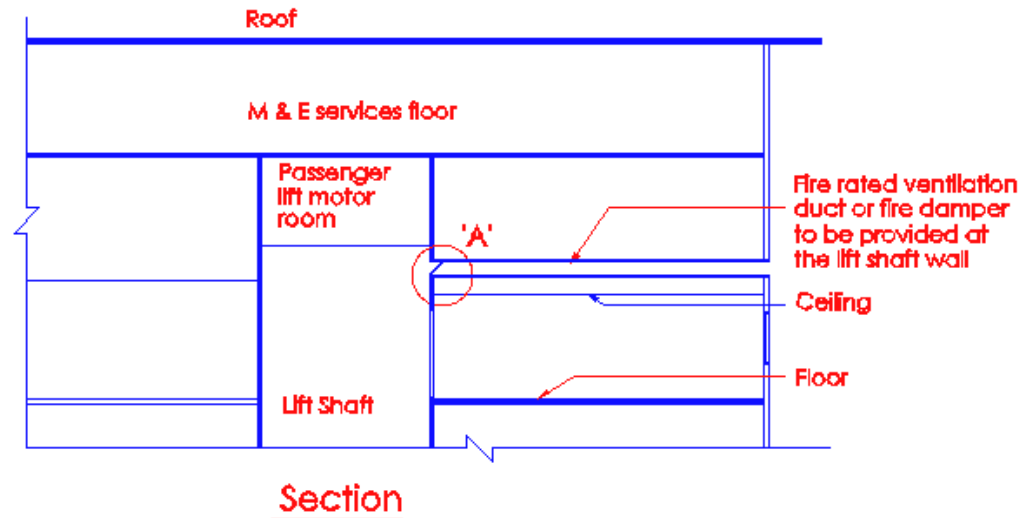

Diagram 3.8.8(d) - 2

All lift shafts shall be vented at the top in accordance with SSCP 2. In situations, where the lift shafts could not be brought above the roof as shown in diagram 3.8.8(d) – 2, horizontal fire rated duct could be used to provide air relief to the lift shaft. If the duct is not fire rated, appropriate fire damper could be provided in the wall of the protected lift shaft as shown 'A' in the above diagram. The above relaxation shall not be applicable to fire lift.

- 3.8.8 (f) Transom panel above lift entrance shall be considered as part of the protecting structure and shall therefore conform to the fire resistance requirements of the protected structure.

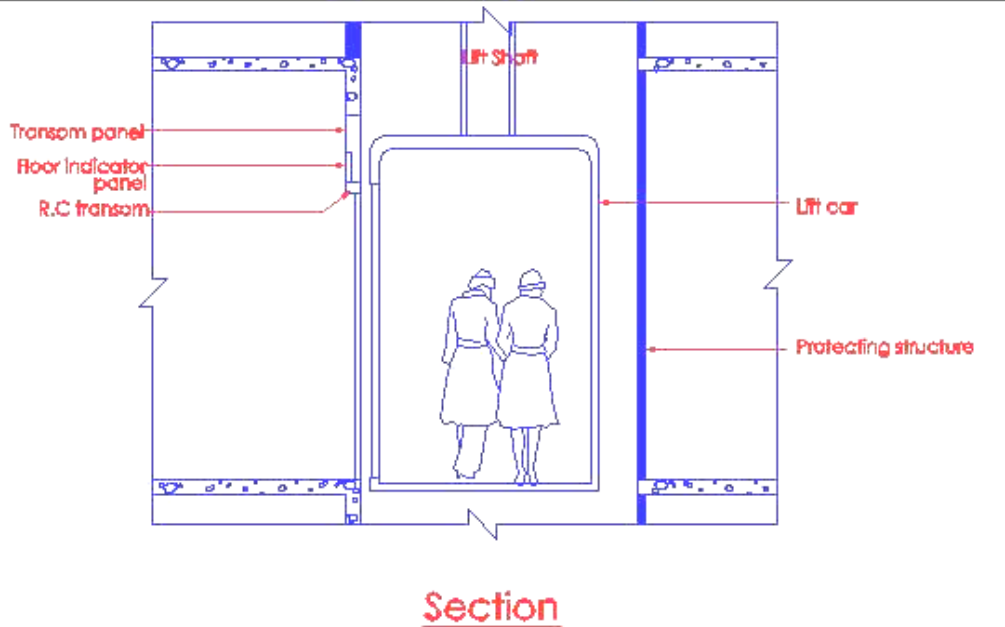

Diagram 3.8.8(f)

Floor indicator panel should be surface mounted. If it is built into the transom panel, care should be taken to ensure that the fire resistance of the panel is not lowered. It is a common mistake to puncture the transom panel to receive the floor indicator panel without giving consideration to the fire integrity of the panel. Such practice contravenes the above requirement, as Cl.3.8.2 requires that the protecting structure, including the transom panel, forms a complete barrier and should have the appropriate fire resistance rating.

- 3.8.8 (g) If it serves any basement storey and not in the vicinity of any void connecting to upper levels or any external spaces, there shall be provided a lobby enclosed by walls having fire resistance of not less than 1 hour and fire door of not less than half an hour.

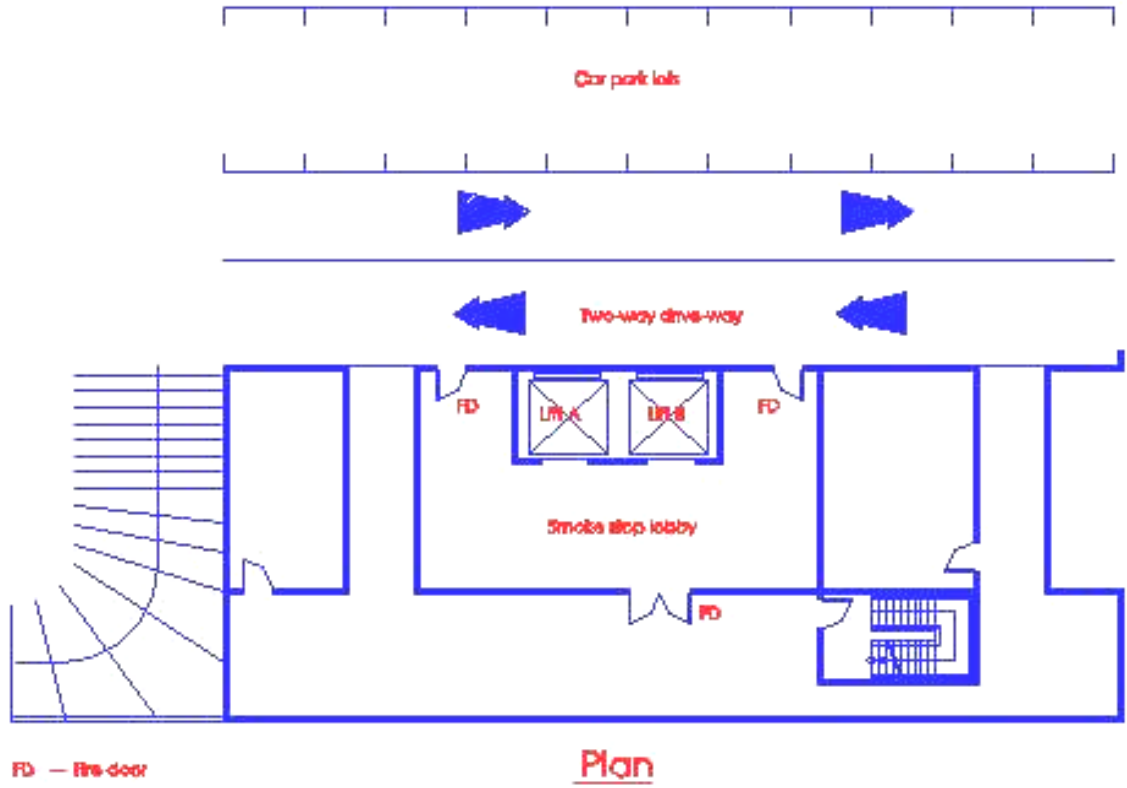

Diagram 3.8.8(f) - 1

Lift opening into basement and not adjoining a void that opens to the sky or any external spaces, shall be provided within a smoke stop lobby having 1-hour fire rated enclosures and ½ hour fire door.

The smoke-stop lobby acts as a buffer zone to prevent smoke from being drawn into the lift shaft through the 'piston-effect' of the movement of the lift.

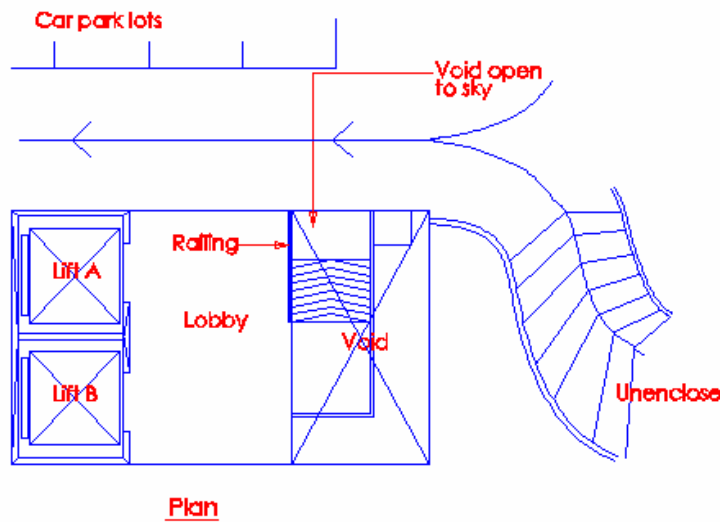

Diagram 3.8.8(f) - 2

Lift opening into basement storey and adjoining a void opening to the sky or any external spaces does not require a smoke-stop lobby. Smoke occurring in the vicinity of the lift would be drawn into the void and vented upward into the open space. This provision would help to reduce the chance of smoke being sucked into the lift shaft.

3.8.8 (h) Private Lift

Private lifts that are provided for the exclusive use of occupants in residential units under purpose group II buildings shall comply with the following requirements :

- (i) Smoke detectors shall be provided at the lift landing area. The activation of any of the smoke detectors at the lift landing area shall cause the lift to home to the designated floor; and
- (ii) Emergency power supply from a generating plant shall be provided to home the lift to the designated floor when there is a power failure in the building; and
- (iii) The lift shall not be permitted to double-up as a fire lift; and
- (iv) Private lifts shall comply with SS CP 2.

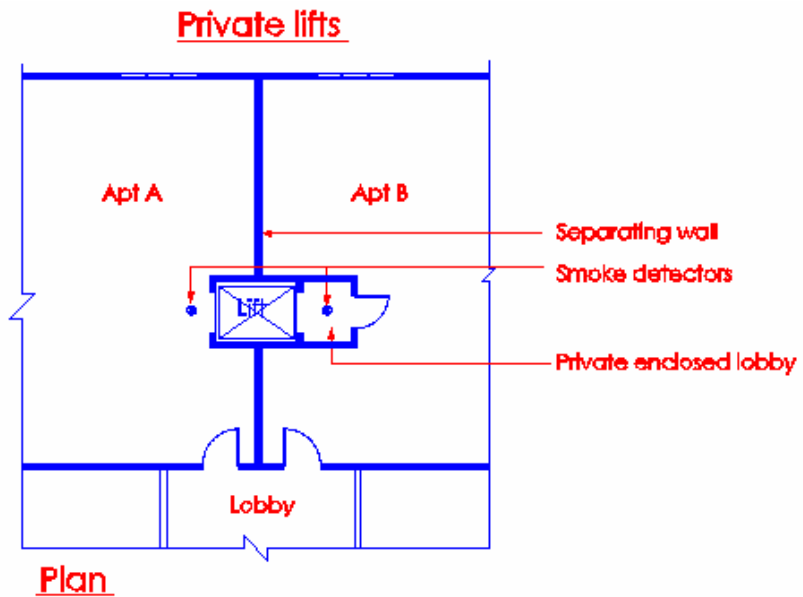

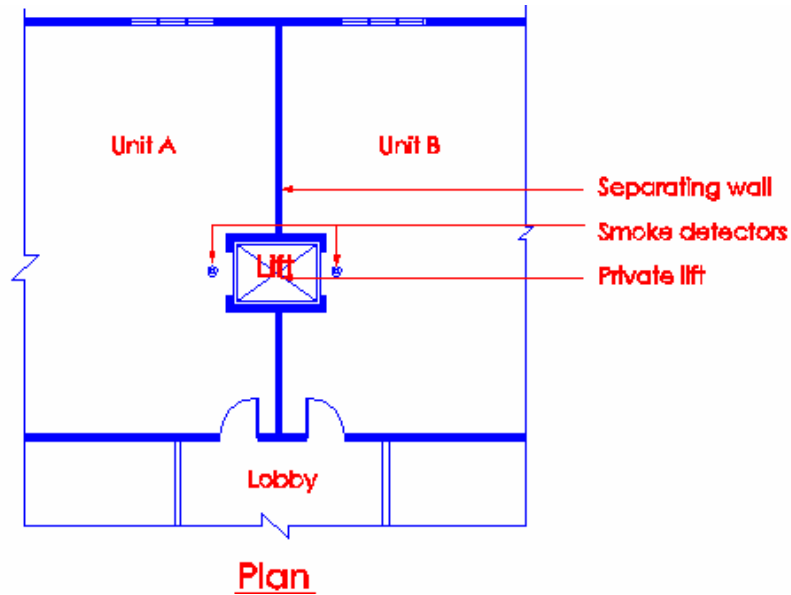

Diagram 3.8.8(h) -(1) & (2)

3.8.9 Protected shaft containing other services installations

A protected shaft used for the enclosure of services shall comply with the following:

- (a) The protecting structure for protected shaft containing kitchen exhaust ducts and mechanical ventilation ducts serving areas specified in Cl.5.2.1(g)(i) to (iii) and (h) which pass through one or more floor slabs shall be of masonry or drywall. Such shaft shall be completely compartmented from the rest of the shaft space containing other ducts or any other services installations. Protected shaft containing ducts serving other areas which pass through two or more floor slabs shall be constructed of drywall. If the protecting structure for the protected shaft is constructed of drywall, the following conditions shall be complied with :
 - (i) Drywall shall be non-combustible; and
 - (ii) Drywall shall have fire resistance for not less than the relevant period specified in Table 3.3A having regard to the purpose group of the building of which it forms a part and the dimension specified in that Table; and

- (iii) Drywall shall meet the criteria, in terms of impact and deflection performance, when subject to the tests of BS 5588 Pt 5 Appendix A and BS 5234 Pt 2; and
- (iv) Drywall shall meet the criteria, in terms of water absorption and bending strength; and performance, when subject to the test of BS 1230 Pt 1 (for gypsum plaster board) or ISO 1896 (for calcium silicate or cement board).

The protecting structure for protected shaft containing kitchen exhaust duct and mechanical ventilation ducts which pass through one or more floors and serving areas such as:

- (i) exit staircases and exit passageways
- (ii) Smoke-stop and fire fighting lobby
- (iii) Areas of refuge within the same building
- (iv) Emergency generator
- (v) Engine driven fire pump

shall be constructed in masonry. Each shaft shall be separately compartmented from one another. Protected shaft containing ducts serving other areas not mentioned above and which pass through two or more floors can be constructed of fire rated materials, instead of masonry.

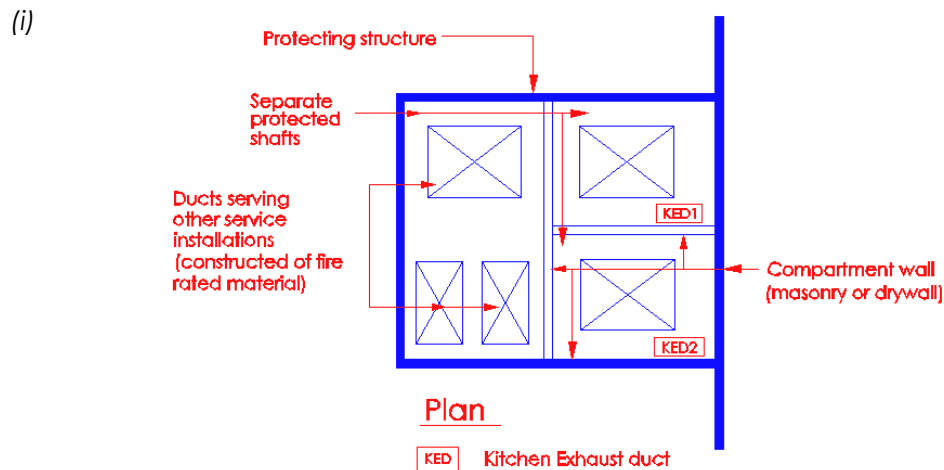

Diagram 3.8.9(a)-1

E.g. Kitchen exhaust duct shall be in a separate compartment from that for a mechanical ventilation duct. Kitchen exhaust ducts serving different kitchens shall be in separate shafts. Mechanical ventilation duct serving the area of refuge shall be in different shaft from that serving the pump room. The main reason for separate shafts is to prevent smoke and fire spread from shaft to shaft.

(ii)

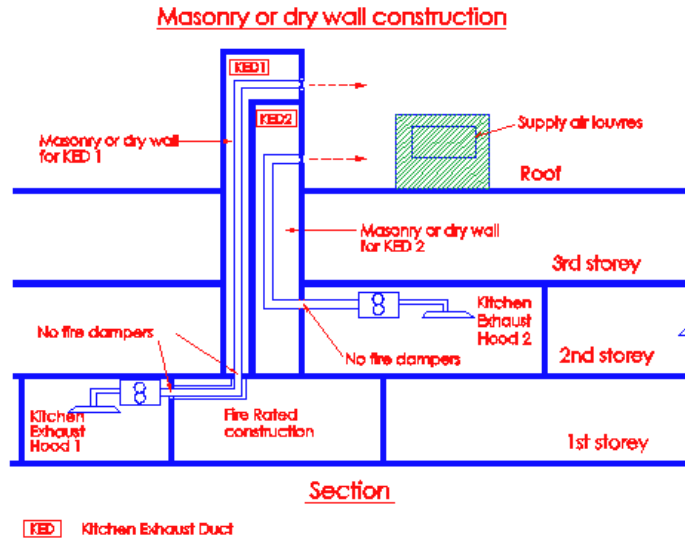
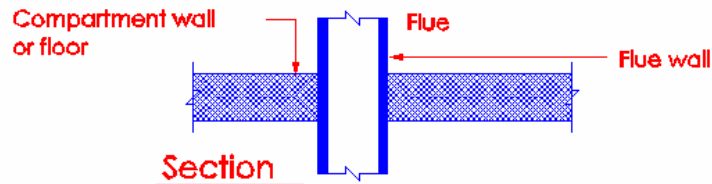

Diagram 3.8.9(a)-2

Kitchen exhaust shaft for each kitchen is completely separated. The horizontal run of the exhaust from kitchen 1 is protected with fire rated material.

(iii)

a. Flue passing through compartment wall or floor



Flue walls should have a fire resistance of at least one half of that required for the compartment wall or floor, and be of non-combustible construction

b. Flue built into compartment wall

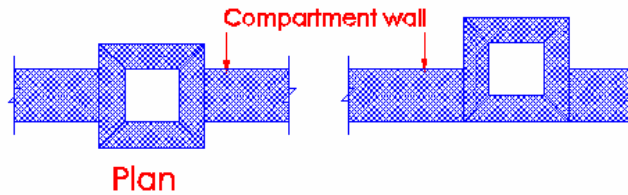

In each case flue walls should have a fire resistance of at least one half of that required for the compartment wall and be of non-combustible construction

Diagram 3.8.9(a)-3

If a flue, or duct containing flues or appliance ventilation duct(s), passes through a compartment wall or compartment floor, or is built into a compartment wall, each wall of the flue or duct should have a fire resistance of at least half that of the wall or floor in order to prevent the by-passing of the compartmentation.

- 3.8.9 (b) Protected shaft used for the enclosure of electrical power services shall be interrupted at every floor level with barriers with fire resistance of at least half an hour. Protected shaft used for the enclosure of telecommunications cables shall be interrupted by barriers with fire resistance of at least half an hour at vertical intervals not exceeding 15m. Such cavity barriers shall comply with the relevant provision of Cl.3.11.

(i)

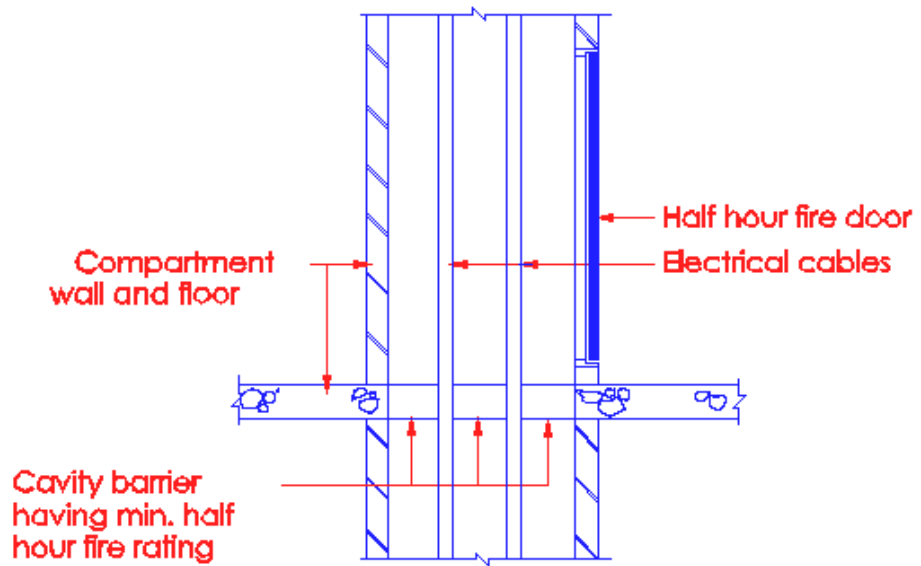

Diagram 3.8.9(b)-(i)

Protected shaft containing electrical cables shall be interrupted at every floor with cavity barrier having min. ½ hour fire rating to prevent vertical spread of fire and smoke. The main concern is that cables are a source of fuel and ignition. The presence of fire stopping at every floor would help to confine fire to a single storey or segment of the shaft.

- (ii) Protected shaft containing Telecom cables

Protected shaft used for the enclosure of telecommunications cables shall be interrupted by barriers with fire resistance of at least half an hour at vertical intervals not exceeding 15 m. Such cavity barriers shall comply with the relevant provisions of Cl. 3.11.

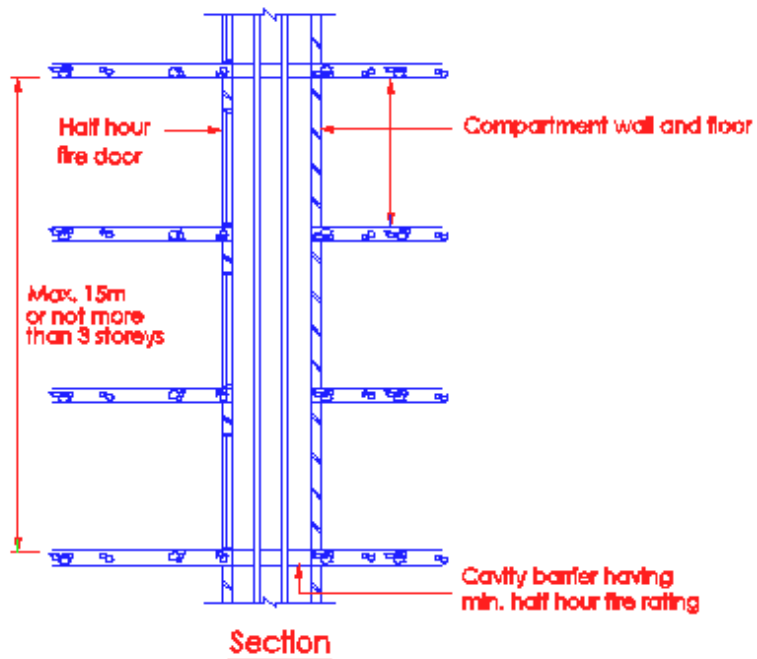

Diagram 3.8.9(b)-(ii)

Protected shaft containing telecommunications cables including cable TV lines is provided with cavity barrier at vertical intervals not exceeding 15m or 3 storeys whichever is the shorter. The cables are mainly of low voltage and hence of a lower risk when compared to electrical cables.

3.8.9 (c) Omission of self-closing device

In the case of protected shafts which are interrupted by barriers with fire resistance of at least half an hour at every floor level, fire resisting doors opening into the protected shaft may not be required to be installed with automatic self-closing devices, provided such doors are kept closed and locked at all times.

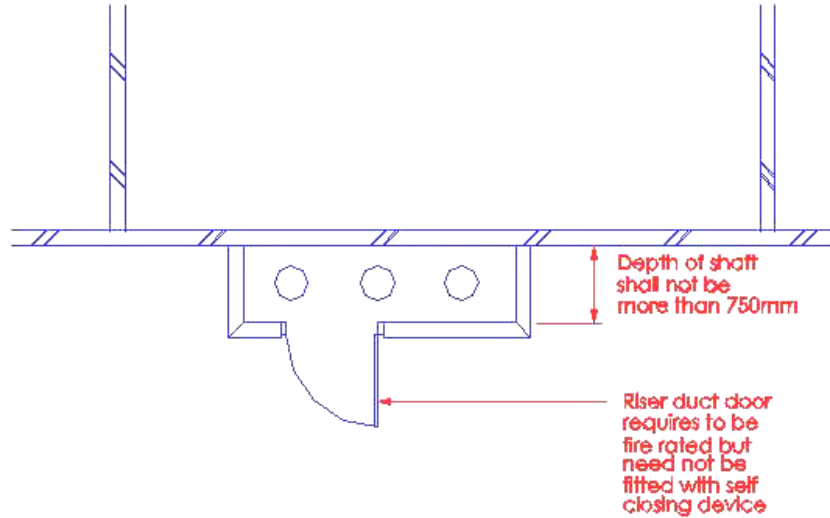

Diagram 3.8.9(c)

Provision of self-closing device for the inspection door of a protected shaft, which is interrupted by barriers having ½-hour fire resistance at every floor, is not required. The above relaxation is also applicable to TAS shafts, provided they are interrupted by barriers with fire resistance of at least ½-hour at every floor level.

An important point to note is the depth of the shaft which shall not exceed 750mm. If it exceeds 750mm, the shaft would be considered as a room and provision of self-closing device for the fire door becomes a necessity.

The above relaxation is based on the understanding that it is unlikely that a shaft would be converted to a store if its depth is less than 750mm and that the door would normally be kept in the locked position when workmen are not carrying out servicing work. Also, maintaining the door in locked position is the responsibility of the management corporation of the estate.

3.8.9 (d) Exception

All protected shafts containing services shall not be located within an exit staircase except for the case of residential apartment/maisonette development under purpose group II not exceeding 4-storey where smoke stop is not required.

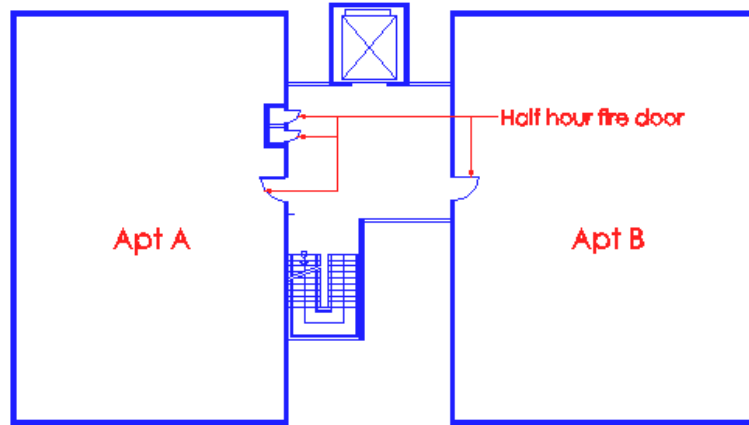

Diagram 3.8.9(d)-1

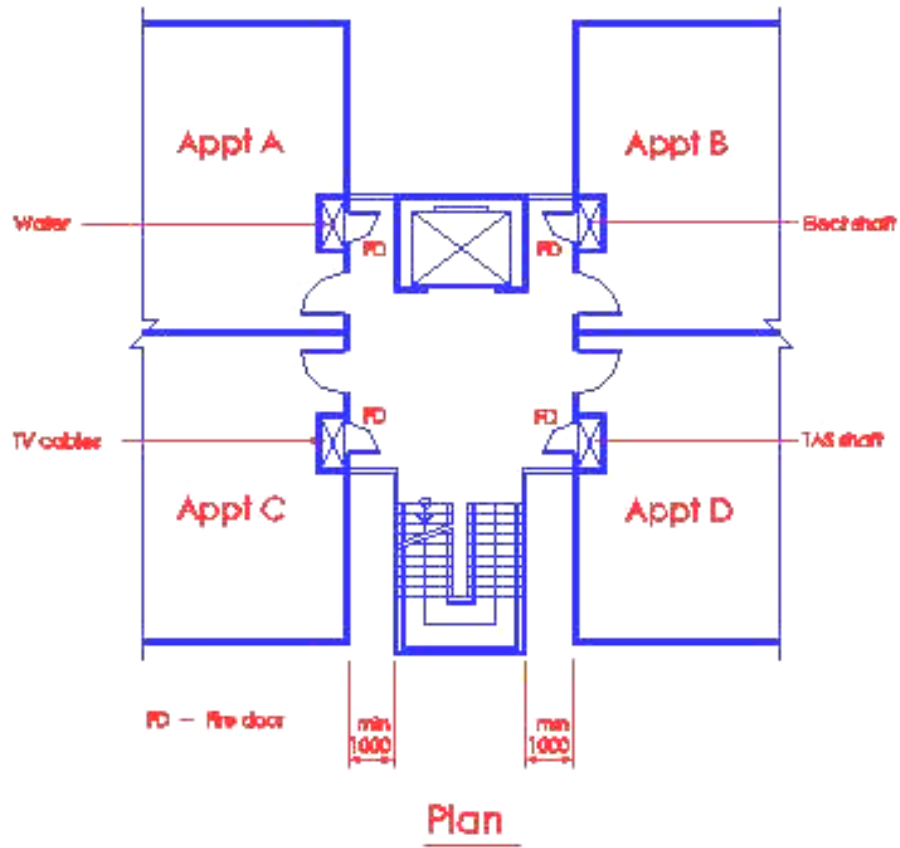

Diagram 3.8.9(d)-2

Protected shafts such as for lift, TAS/Elect/Water/Cables are permitted to be located within a protected shaft containing an exit staircase for buildings under Purpose Group II, provided :

- a) that building does not exceed 4 storey where provision of smoke stop lobby is not a requirement; and*
- b) that no shaft shall contain pipes carrying gas or combustible liquids.*

The above exception is only applicable to low-rise buildings where provision of smoke stop lobby is not a requirement and that the staircase would be naturally ventilated. However, where there is availability of common area, such services shall be located outside the staircase shaft, see diagram 3.8.9(d) – 2.

3.9 PROTECTION OPENINGS

- 3.9.1 The provision of this Clause are made in connection with the protection of openings permitted in elements of structure or other forms of fire resisting construction required to act as a barrier to fire and smoke.

(No illustration)

For functional purposes, openings in compartment walls, floor etc are required in buildings to allow movement of people and the installation of services such as pipes, ventilation ducts etc. To prevent the spread of fire and smoke, such openings shall be appropriately protected.

- 3.9.2 Fire doors

Fire doors for protection of openings shall comply with the following:

- (a) Fire resisting doors shall have the appropriate fire resistance as required by relevant parts of the Code, and two fire resisting doors may be fitted in an opening if each door by itself is capable of closing the opening and the two doors together achieve the required level of fire resistance, and

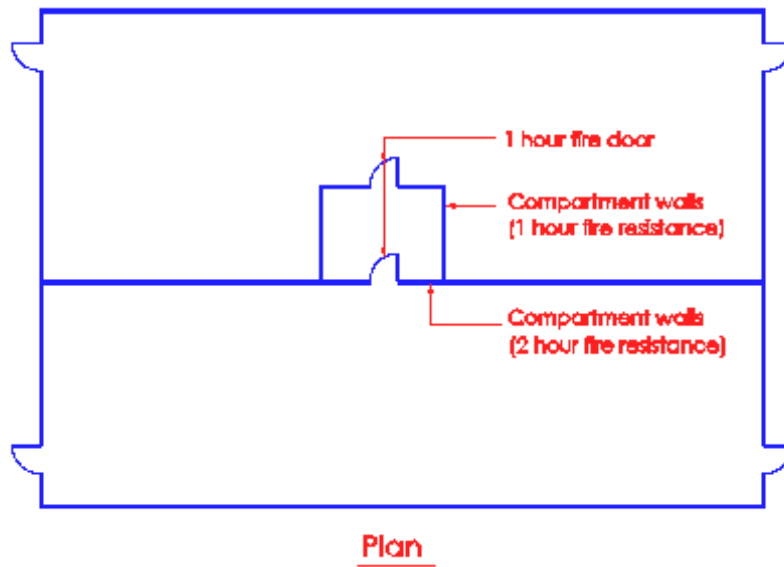

Diagram 3.9.2(a)-1

The two 1 hour fire door arrangement is deemed to satisfy compartmentation and be equivalent to the fire resistance rating of the compartment wall (2 hours).

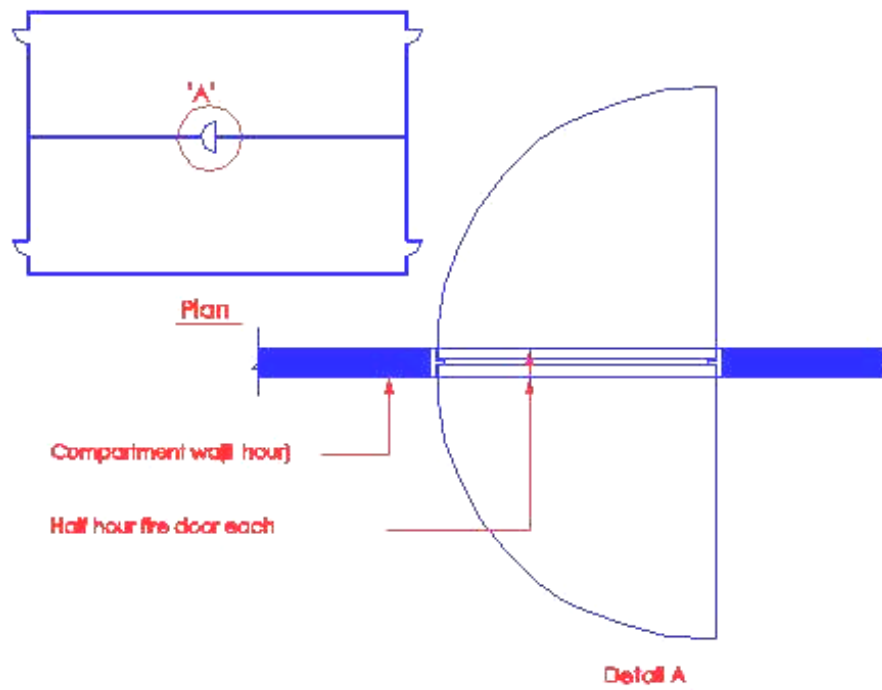

Diagram 3.9.2(a)-2

The provision of fire doors shown in the above diagram usually occur in separating walls, compartments or protecting structures. The provision of two fire resisting doors would not be applicable to exit openings to apartment or maisonette units.

- (b) All fire doors shall be fitted with an automatic self-closing device which is capable of closing the door from any angle and against any latch fitted to the door, and

(No illustration)

All fire doors are required to be fitted with an automatic self-closing device which shall not include rising butt. Self-closing device is not required to be fitted to doors of protected shafts having a depth of not more than 750mm under sub-clause 3.8.9(c).

Fire resisting door to exit openings of apartment/maisonette units, protected staircases, protected lobbies, exit passageway, compartment walls etc. shall have minimum half hour fire resistance. Doors to exit facilities shall not be fitted with any locking device. However, doors to exit openings of apartment/maisonette units would be fitted with locking devices for security reasons. As fire door is to protect the openings in exit facilities, it should always remain in the closed position to prevent the spread of smoke and heat. The main function of the self-closing device is to return the door to its closed position after being opened for movement of occupants, goods etc. The passage latch fitted to the door is to hold the fire door in closed position to counteract the pressure differential between the door in a fire situation.

Many private residential apartment/maisonette buildings have card key access or automatic locking devices fitted to doors of exit staircases to prevent unauthorised access by outsiders.

To gain entry into the staircase or to exit from it into any floor, the occupants need to key in a code number or use a card key access to unlock or release the locking device to the door. In times of power failure or activation of fire alarm system, if available, the locking device would be unlocked by itself and all the exit doors could be opened manually. Prior approval should be obtained from FSSD before any door to exit facilities is fitted with any form of locking device.

When the door to the exit facilities consists of double leaves or multiple leaves, all the leaves shall be fitted with self-closing device and sequential closer.

Where the entrance door of the apartment or maisonette unit consists of large and small leaves, self-closing device shall be required to be provided to the large leaf, provided the clear width of the opening of the large leaf when open at an angle of 90° is not less than 850mm. The smaller leaf is not to be taken into consideration as it would usually be bolted-shut, unless there is a need to open it for movement of large furniture, etc. If the door opening has 2 leaves of equal width for use as exit to meet the minimum clear width of opening under Cl.2.2.9(b), both leaves shall be fitted with self-closing device and sequential door closer.

Self-closing device to fire door shall be properly maintained regularly. Faulty device shall be repaired immediately to prevent fire door being left in the open position.

(c) Where a self-closing device would be considered a hindrance to the normal use of the building, fire resisting doors may be held open as follows :

(i) by a fusible link, or

(ii) if the doors can be opened manually, by electromagnetic or electro-mechanical devices which can be activated by the presence of smoke and/or the building alarm system,

(See illustration in Cl.1.2.20 under Definition in Volume I)

(d) Any hinge on which a fire resisting door is hung shall be made entirely of non-combustible materials having a melting point of at least 800^o C , and

(No illustration)

(e) Any fire door fitted in an opening which is provided as a means of escape:

(i) shall be capable of being opened manually, and

(ii) shall not be held open by any other means other than by an electromagnetic or electro-mechanical device which can be activated by the presence of smoke and/or the building alarm system, provided that this shall not apply in the case of fire-resisting doors opening into pressurised exit staircases.

(iii) shall open in the direction of exit travel in accordance with Cl. 2.3.9.

(See illustration in Cl.1.2.20 under Definition in Volume I)

(f) Fire doors where required to be provided shall be constructed and installed to comply with specifications stipulated under SS 332 Specification for Fire Doors.

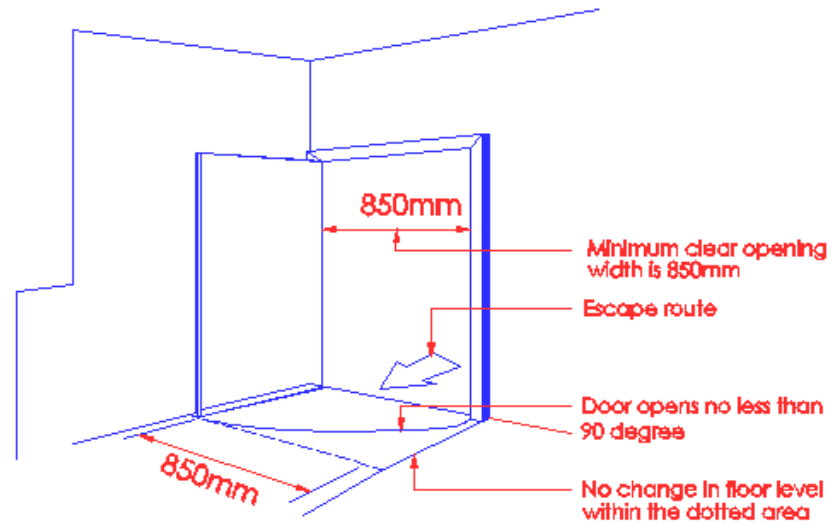

Diagram 3.9.2(f)

All fire doors are required to bear PSB label and listed under the Product Listing Scheme of Productivity and Standards Board. It is important to note that fire door opening into pressurised exit staircases shall not be fitted with electromagnetic or electro-mechanical device. This is to ensure that the integrity of the pressurised exit staircase is maintained at all times.

3.9.3 Pipes

Pipes which pass through a separating wall, compartment wall or compartment floor shall be kept as small as possible and fire-stopped around the pipe. The nominal internal diameter of the pipe shall be not more than the relevant dimension given in Table 3.9A. Spacing between pipes shall be minimum 50mm or ½-diameter of the largest pipe, whichever is the larger.

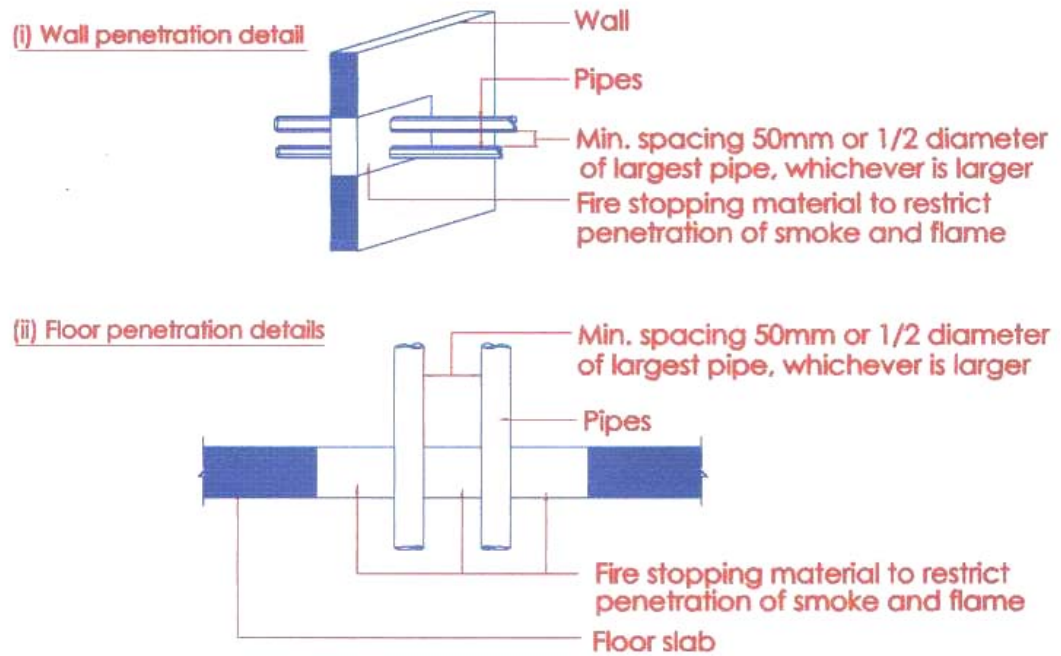

Diagram 3.9.3-1

The clustering of pipes without proper spacing would further weaken the integrity of the fire resisting walls in times of fire emergency.

Penetration of elements of structure by pipes

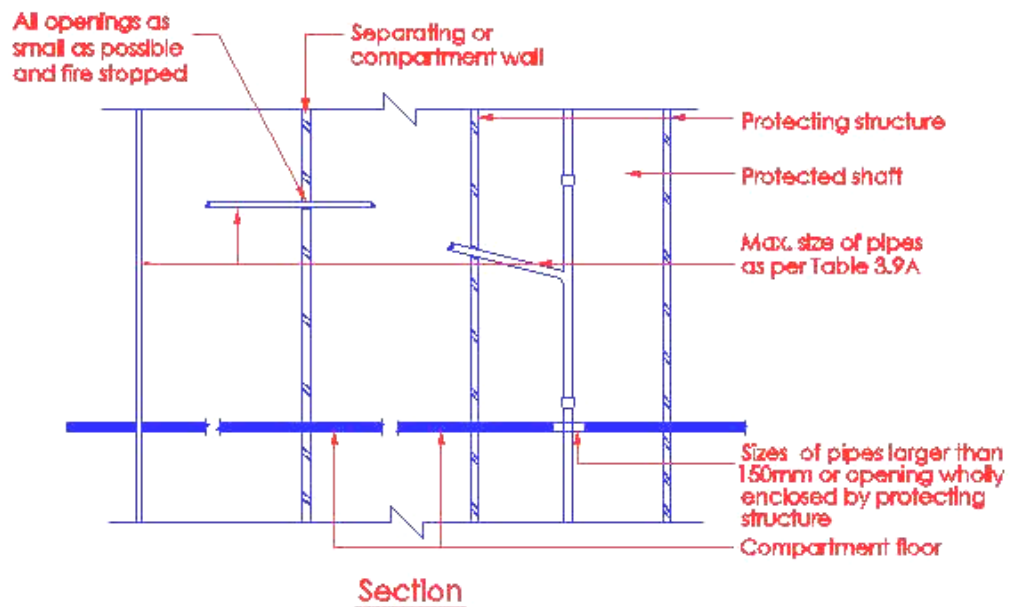

Diagram 3.9.3 – 2

UPVC pipes located in external corridor

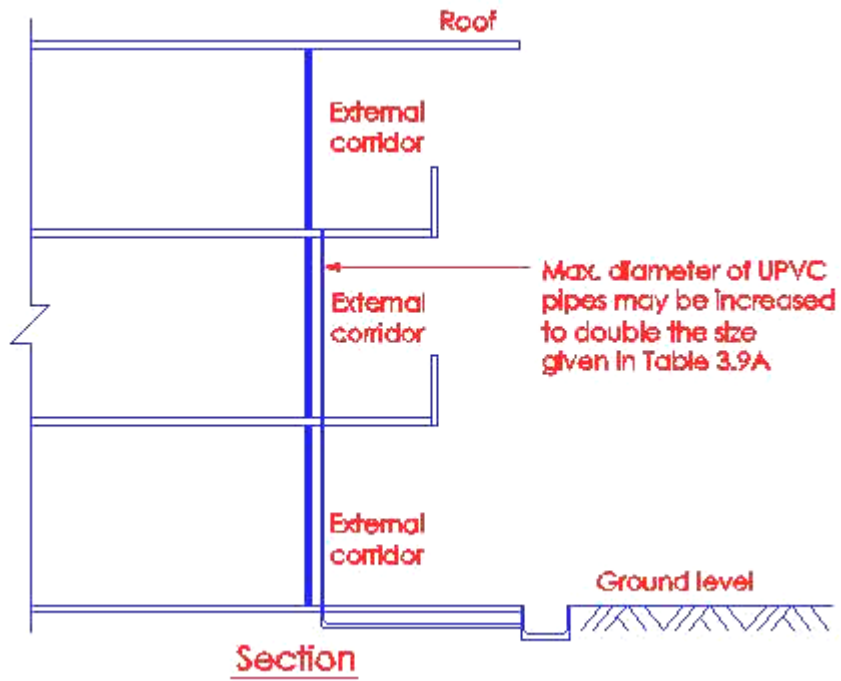

Diagram 3.9.3 - 3

External corridor would be well ventilated. Hence fire risk is lower and the threat of spread of fire and smoke from floor to floor is very much reduced.

TABLE 3.9A MAXIMUM NOMINAL INTERNAL DIAMETER OF PIPES

Situation	Pipe material and maximum nominal internal diameter [mm]		
	Non-combustible material	Lead, aluminium or aluminium alloy, or UPVC ²	Any other material
When the pipes penetrate the structure enclosing a protected shaft which is not an exit stairway or lift shaft	150	100	40
Any other situation	150	100 (stack pipe) ³ 75 (branch pipe) ³	40

Notes

- 1) A non-combustible material (such as cast iron or steel) which if exposed to a temperature of 800 degrees Celsius will not soften nor fracture to the extent that flame or gases will pass through the wall of the pipe.
- 2) UPVC pipes complying with SS 141 or SS 213.
- 3)
 - i) Within toilets, wash rooms or external corridors, maximum diameter of UPVC pipes may be increased to double the size given in the above table.
 - ii) Within areas of fire risk, such as kitchens, and adjacent to escape routes, UPVC pipes shall be enclosed by construction having fire resistance of at least one half hour.
 - iii) Where the size of UPVC pipes exceeds that specified under this Clause, approved fire collar shall be fitted at all positions where such pipes pass through constructions required to act as a barrier to fire.
- "Any other situation" refers to separating wall, compartment wall/floor and other similar construction.

Table 3.9A lists three specifications which control the max. internal diameter of the pipes which penetrate elements of structure as follows:

a) 150mm diameter pipes of non-combustible material	Pipes which will not soften or crack sufficiently to permit passage of hot gases or flames when exposed to temperatures up to 800°C. If the pipe size exceeds 150mm, it shall be located within a protected duct or shaft
b) 100mm diameter (stack) and 75mm diameter (branch) pipes	<p>Pipes of lead, aluminum or alloy and UPVC (complying to SS 141 or SS213) which would soften or crack sufficiently to permit passage of hot gases or flames when exposed to temperature below 800°C. Pipes of lead, aluminum or alloy exceeding 100mm diameter (stack) and 75mm diameter (branch) shall be located within a protected shaft or duct. UPVC pipes located in areas of fire risk such as kitchens or adjacent to escape routes shall be enclosed in protecting structure having min. 1 hour fire resistance rating or following that of the elements of structure, whichever is greater.</p> <p>UPVC pipes located in other areas exceeding the sizes of 100mm (stack) or 75mm (branch) shall be fire stopped by approved fire collar at penetration of elements of structure.</p> <p>Exception:</p> <p>Internal diameter of UPVC pipes located within toilets, wash rooms which are considered as "wet area" and in external corridor may be double that given in Table 3.9A</p>
c) 40mm diameter pipe	Pipes of any other material shall not exceed 40mm unless located in protected duct or shaft

3.9.4 Ventilation ducts

Ventilation duct which passes directly through a compartment wall or compartment floor shall comply with the following -

- (a) Where the ventilation duct does not form a protected shaft or is not contained within a protecting structure,

- (i) the duct shall be fitted with a fire damper where it passes through the compartment wall or compartment floor, and
- (ii) the opening for the duct shall be kept as small as practicable and any gap around the fire damper shall be fire-stopped.

Proper fire stopping around the duct where it penetrates the compartment floor/wall and provision of fire damper at the compartment wall/floor would help to prevent fire and smoke spread from compartment to compartment.

- (b) Where the ventilation duct forms a protected shaft or is contained within a protecting structure, the duct shall be -
 - (i) fitted with fire dampers at the inlets to the shaft and outlets from it, and
 - (ii) constructed and lined with materials in accordance with the requirements in Chapter 7.

Drawing 3.9.4(a)

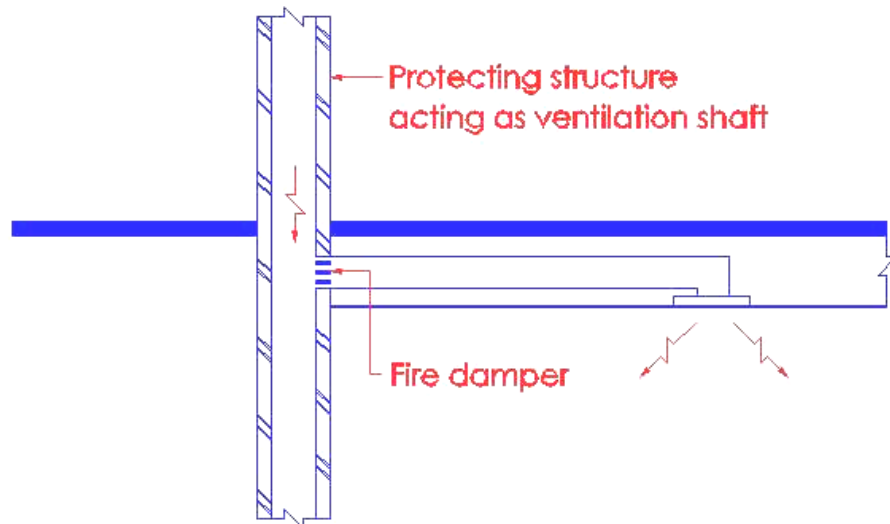

Drawing 3.9.4(b)

The provision of fire damper at the entry to the protected shaft would help to complete the compartmentation to prevent fire or smoke from being drawn into the protected shaft via ventilation duct.

- (c) The installation of ventilation ducts and fire dampers shall comply with the requirements in Chapter 7.

3.9.5 Flues

Duct encasing one or more flue pipes which passes through a compartment wall or compartment floor shall be of non-combustible construction having fire resistance of not less than half the minimum period of fire resistance required for the compartment wall or compartment floor through which it passes, except for kitchen flue pipes when the fire resistance shall be as required for the compartment wall or compartment floor.

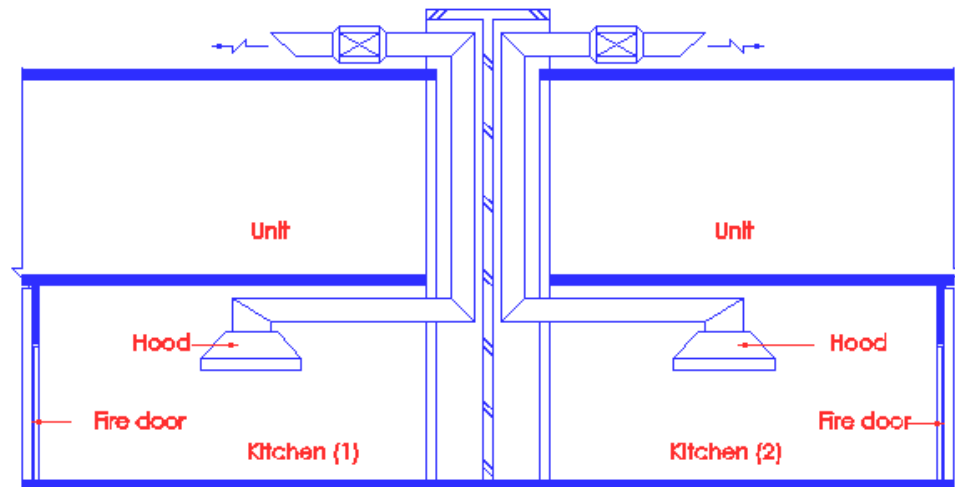

Drawing 3.9.5 – 1

Separate kitchen exhaust shaft enclosed in masonry or drywall construction shall be provided for Kitchen (1) and (2). This is to prevent fire and smoke from spreading from one compartment to another. The wall enclosing the shaft shall have the same fire resistance as the compartment wall or floor.

3.9.6 Service pipings and ductings

Air ducts, sanitary pipings, gas pipes and other services that are likely to permit the passage of flame or smoke in the event of a fire shall not be permitted to pass through rooms housing fire pump, emergency generator or fans handling smoke control system except where such services are required for the operation of these equipment.

(No illustration)

3.10 EXIT STAIRCASE

3.10.1 Non- combustibility of structure

Every exit staircase, including the treads/risers and landing, shall be constructed of non-combustible materials.

(No illustration)

3.10.2 Structure separating exit staircase

The exit staircase shall be separated from other parts of the building by a masonry structure or drywall complying with CI.3.8.7(c) which shall have fire resistance for not less than the period required by CI.3.3 for Elements of Structure.

(No illustration)

3.10.3 Exit Doors

Doors opening into the exit staircase shall have fire resistance of at least half an hour and fitted with automatic self-closing device.

(No illustration)

3.10.4 Finishes to the ceiling/walls and floors of exit staircase shall be of non-combustible materials.

Internal exit staircase

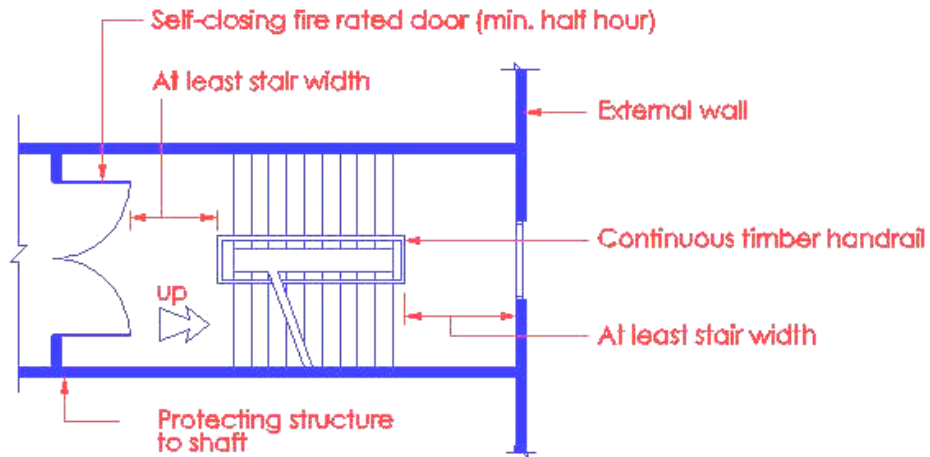

Diagram 3.10.4

The protecting structure, excluding the external wall, to the staircase shall be constructed of non-combustible materials. Ceiling/wall and floor finishes shall be of non-combustible materials to ensure that the level of safety in the staircase is maintained at all times. The only exception allowed is the handrail material.

3.11 CONCEALED SPACES

3.11.1 Concealed spaces in a building shall be interrupted by construction of cavity barrier to restrict the spread of smoke and flames.

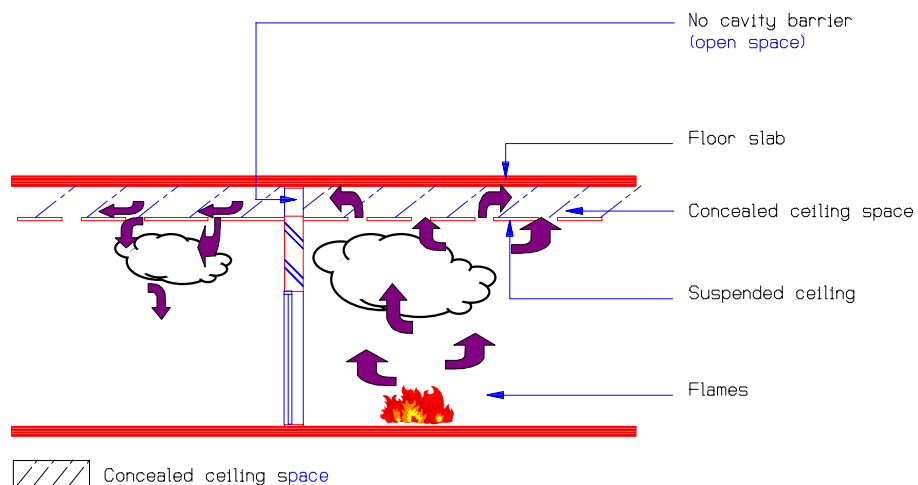

Diagram 3.11.1 - 1

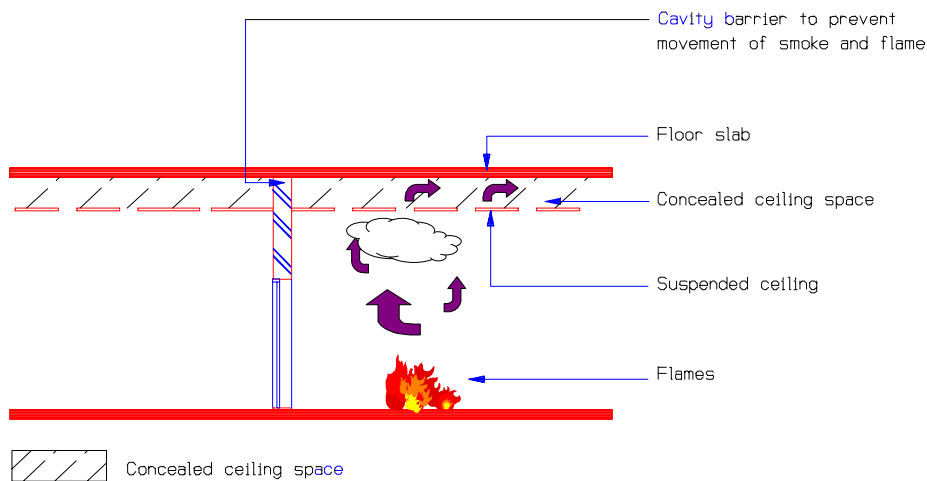

Diagram 3.11.1 – 2

Concealed spaces or cavities in building provide a ready route or flue for smoke and flame to spread undetected for quite some time, thus increasing the risk to life safety of occupants in the building. This is particularly so in the case of void spaces above a suspended ceiling or in a roof space or in a raised floor system. Provisions are available in the Fire Code to reduce the risk of concealed smoke and flame spread by the introduction of cavity barrier when the area or linear dimensions of cavities exceed the limits as per Table 3.11A. Cavity barriers shall be constructed of non-combustible materials and shall have at least half hour fire resistance.

3.11.2 Closing the edges of cavities

Cavity barriers shall be used to close the edges of cavities, edges around openings through a wall, floor and any other part of the construction which contains a cavity and to separate any cavity in a wall, floor or any other part of the construction from any other such cavity.

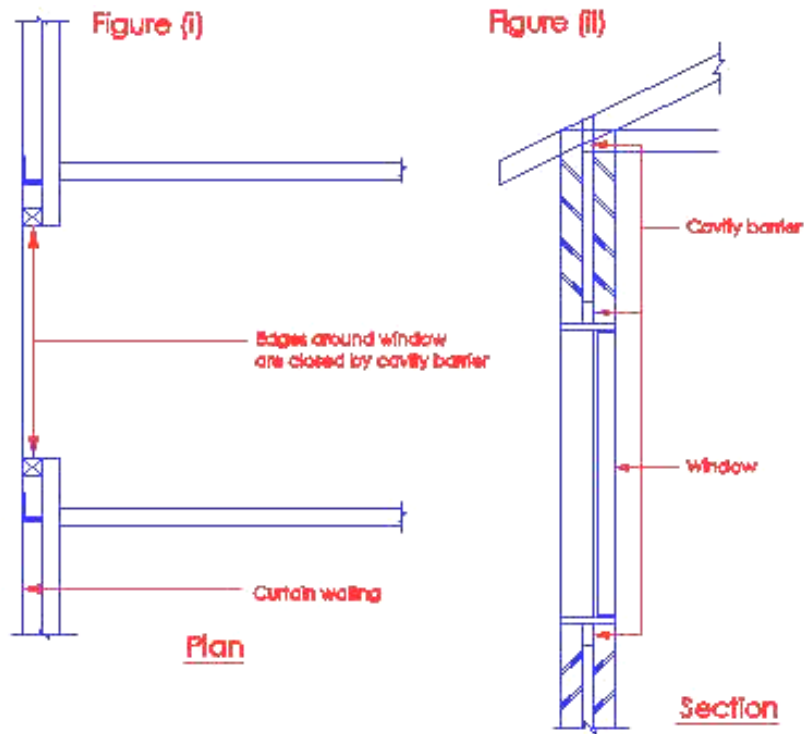

Diagram 3.11.2

“Cavity barrier” means any construction provided to close a cavity against, or restrict the spread of smoke and flame within it.

In figure (i) above, cavity barriers are used to close the edges around the window opening. Similar application is provided to window in external cavity wall in figure (ii).

3.11.3 Interrupting cavities

Cavities including roof spaces shall be interrupted by cavity barriers where a wall, floor, ceiling, roof or other part of the construction abut the cavity, if there is provision for the element of structure to form a fire resisting barrier. Such cavity barriers shall be of fire resisting construction at least equal to the provision for that required for the fire resisting barrier.

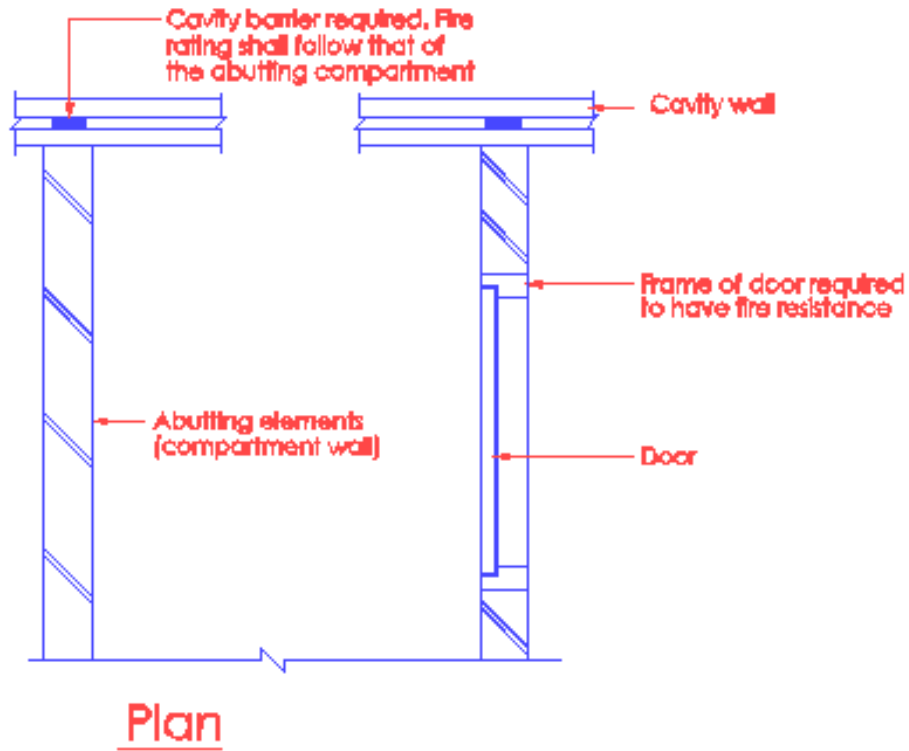

Diagram 3.11.3 – (i)

Cavities must be closed where the fire barrier elements (compartment walls) abut the cavity (including the frame of a door).

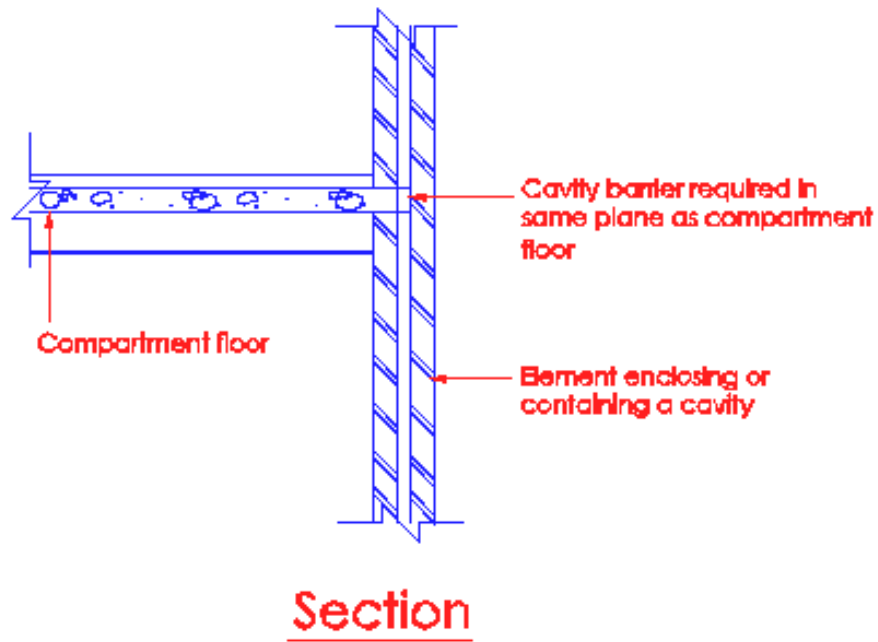

Diagram 3.11.3 – (ii)

Cavity in the walls shall be closed where the compartment floor abuts it.

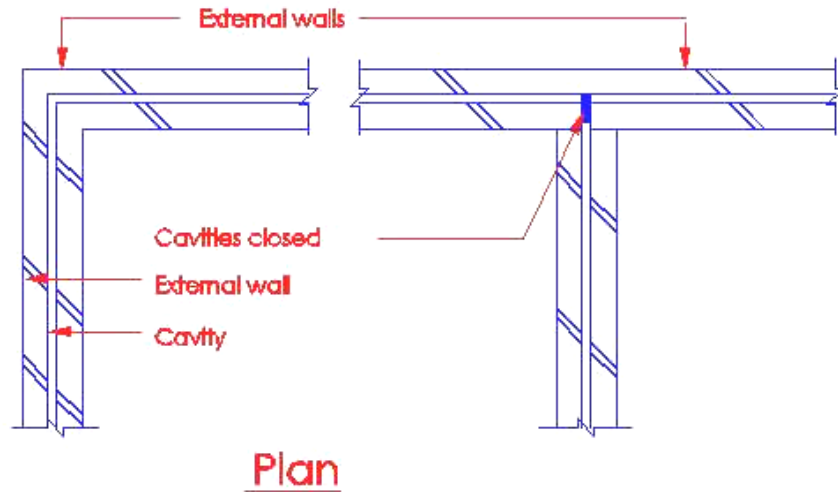

Diagram 3.11.3(iii)

Any cavity within an element, or at the junction of two elements, must be closed by a cavity barrier.

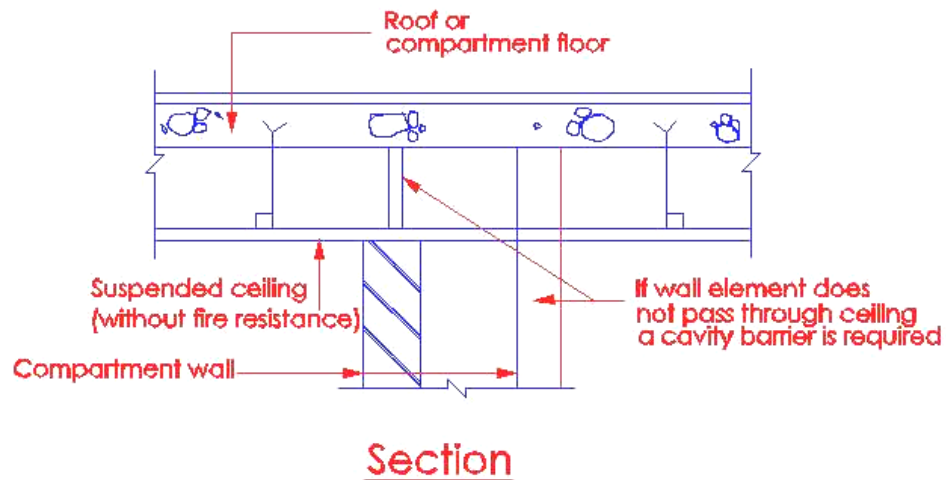

Diagram 3.11.3 – (iv)

It is a common practice to bring the compartment wall right-up to the underside of the structural slab above. The cavity barrier above the compartment wall shall be treated as an extension of the compartment wall below.

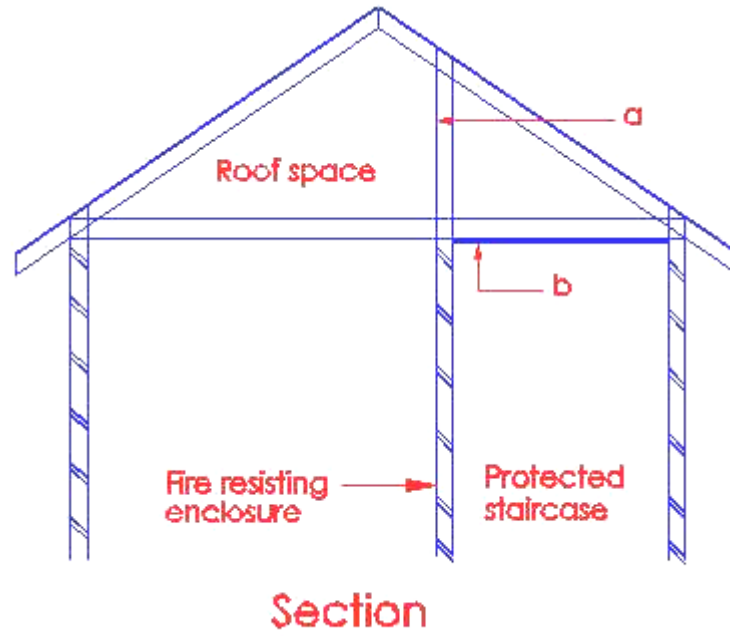

Diagram 3.11.3 – (v)

The roof space over a protected staircase must be separated by either a cavity barrier at (a) having the same fire rating as the wall of the staircase below, or a fire rated ceiling at (b). See Cl.1.2.8 under Definitions, Vol. 1 for further illustration. Extending the masonry wall right-up to the underside of the roof coverings at (a) would meet the requirement under Cl.3.10 of having masonry enclosure to exit staircase. However, in shophouses under conservation, provision of either fire rated wall at (a) or fire rated ceiling at (b) is considered acceptable. This is to avoid additional dead load to the existing building.

3.11.4 Sub-division of extensive cavities

Cavities, including roof spaces, unless otherwise permitted, shall be sub-divided so that the maximum distance between cavity barriers shall not exceed the relevant dimensions given under Table 3.11A.

TABLE 3.11A MAXIMUM DIMENSIONS OF CAVITIES

Location of cavity	Purpose Group of building or compartment	*Class of surface exposed in cavity	Max. dimension in any direction
Between roof and ceiling	I & II	any	no limit
	others	any	20m
Any other cavity	any	Class 0	20m
	any	any	8m
* excluding surface of any pipe, cable, conduit or insulation of any pipe.			

The main reason of limiting the dimension of cavities is to prevent fire or smoke from spreading widely in large concealed space. It is unusual to find extensive cavities, including roof spaces for development under Purpose Group II. Based on the above table, ceiling spaces in buildings under Purpose Group II are not required to be provided with cavity barriers, irrespective of the size of the cavity.

3.11.5 Fire resistance and fixing of cavity barriers

Cavity barriers shall be

- (a) Constructed to provide at least half an hour fire resistance, and
- (b) Tightly fitted to rigid construction or the junctions shall be fire stopped to comply with the requirements of Cl. 3.12.

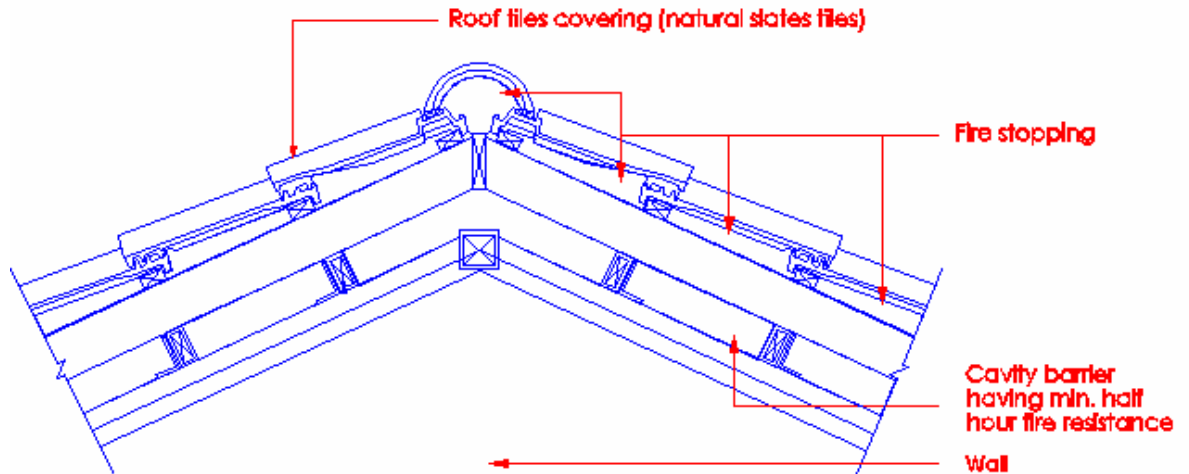

Diagram 3.11.5 - 1

Cavity barriers must be tightly fitted to rigid construction and mechanically fixed in position wherever possible. Where this is not possible (for example, in the case of a junction with slates tiles, corrugated sheeting or similar materials) the junction should be fire-stopped to prevent the spread of fire and smoke in the concealed space.

Cavity barriers must also be fixed so that performance will not be made ineffective by:

- (a) Movement of the building due to subsidence, shrinkage or temperature change; and
- (b) collapse in fire of any services penetrating them; and
- (c) failure in fire of fixings; and
- (d) failure in fire of any material or construction which they may abut. For example, if a suspended ceiling is continued over the top of a fire-resisting wall or partition, and direct connection is made between the ceiling and the cavity barrier above the line of the wall or partition, premature failure of the cavity barrier can occur when the ceiling collapses. However, this does not arise if the ceiling is designed to provide fire protection of 30 minutes or more.

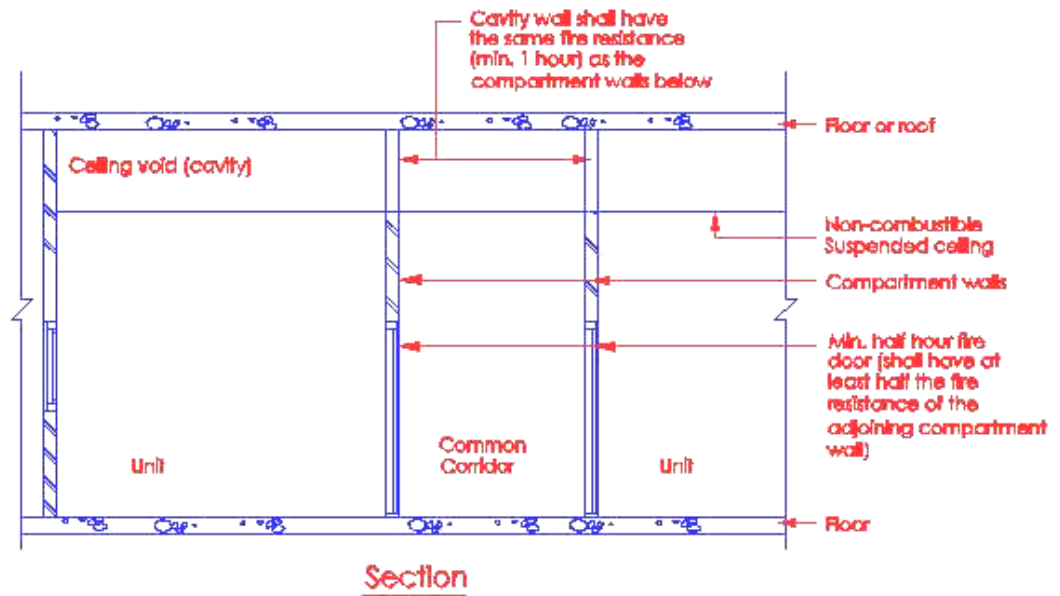

Diagram 3.11.5 - 2

Compartment walls should be carried right up to the full storey height, to a compartment floor above or to the roof coverings, as appropriate. The walls in the ceiling above the common corridor shall not be treated as cavity barriers. They shall be treated as extension of the compartment walls below.

The main purposes of extending the compartment walls into the ceiling space are to complete the compartmentation to each apartment unit and to prevent smoke and fire spread via the concealed ceiling space.

3.11.6 Openings in cavity barriers

A cavity barrier shall have no opening in it except for:

- (a) A door which has at least half an hour fire resistance and shall be kept closed all time,
- (b) A pipe which complies with the provision under Cl. 3.9.3,
- (c) A cable or conduit containing one or more cables,
- (d) An opening fitted with suitably mounted automatic fire damper, and
- (e) A duct which is fitted with a suitably mounted fire damper where it passes through the cavity barrier.

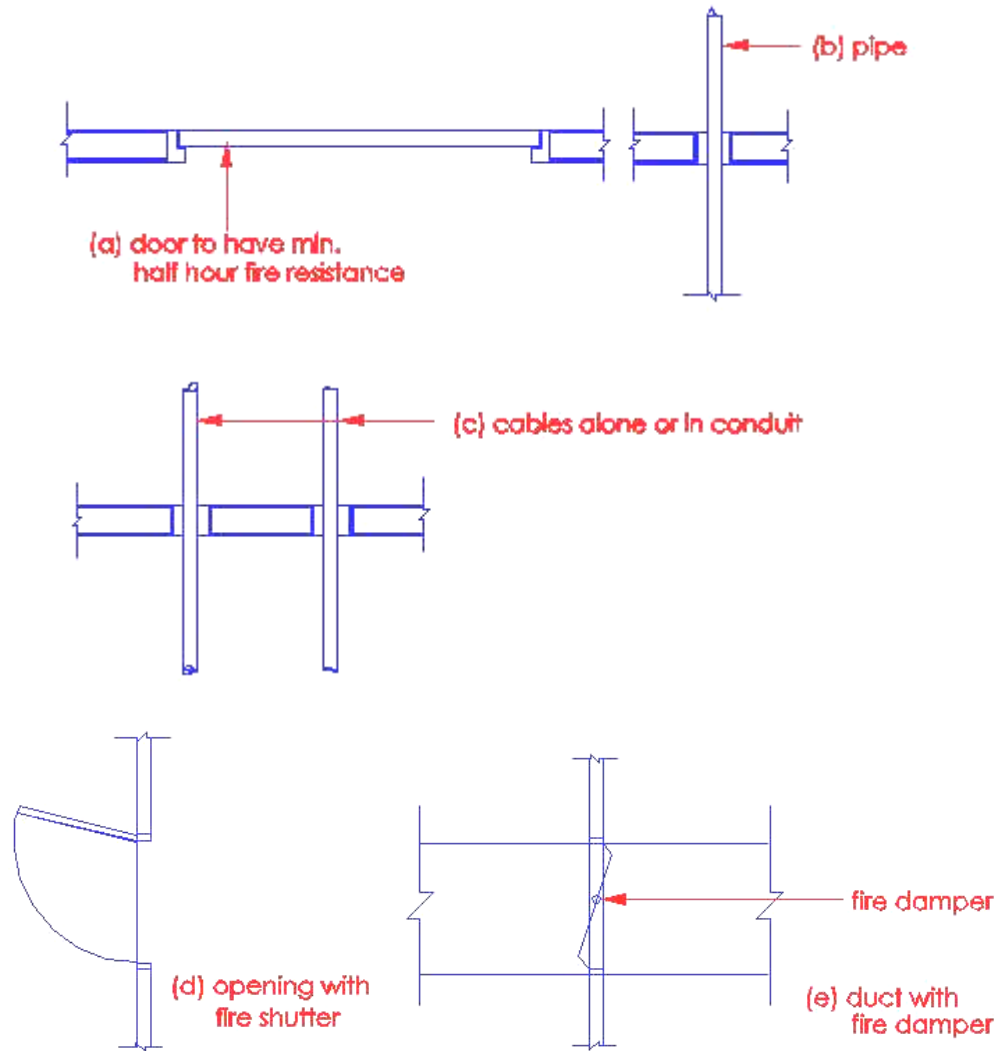

Diagram 3.11.6

Penetrations of cavity barriers shall be restricted to those illustrated above. All openings through cavity barriers must be no larger than necessary and be fire stopped. The fire stopping shall not restrict thermal movement.

3.11.8 Raised floors with or without accessible panels

The construction of raised floors with or without accessible panels shall comply with the following requirements :

- (a) The supporting structure shall be constructed of non-combustible materials having a melting point of at least 800°C, and

- (b) The concealed space between the structural floor and raised floor shall not be used for storage purpose, and
 - (c) No services or installation shall be permitted within the concealed space other than
 - (i) electrical wiring in metal conduit and metal trunking in compliance with the requirements of SS CP 5 Code of Practice for Wiring of Electrical Equipment of Buildings;
 - (ii) communication cables for computer equipment
 - (iii) fire protection installations serving the area, and
- 3.11.8 (d) Where the raised floor is used as a plenum, requirements in Cl. 7.1.1(f) shall be satisfied, and
- (See clause 7.1.1(f) for illustration)*
- 3.11.8 (e) Decking of the raised floor shall be constructed of non-combustible material or where combustible material is used as core material, if allowed in the case of sprinkler protected buildings, the top, bottom, all sides and cut edges shall be covered with material with surface property complying with Class 0 (excluding materials for floor finishes), and

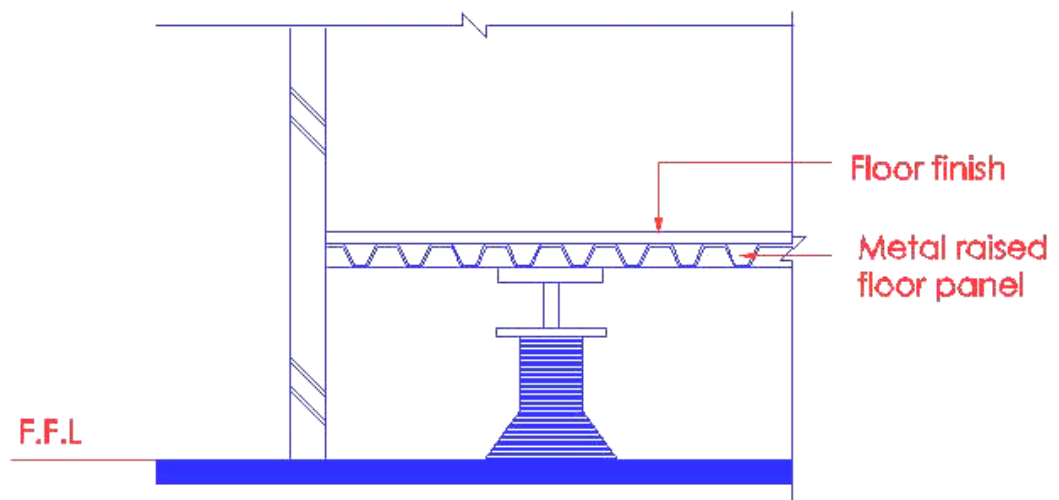

Diagram 3.11.8(e)-1

Non-combustible raised floor panels and supports are allowed to be used in non-sprinkler or sprinkler protected buildings.

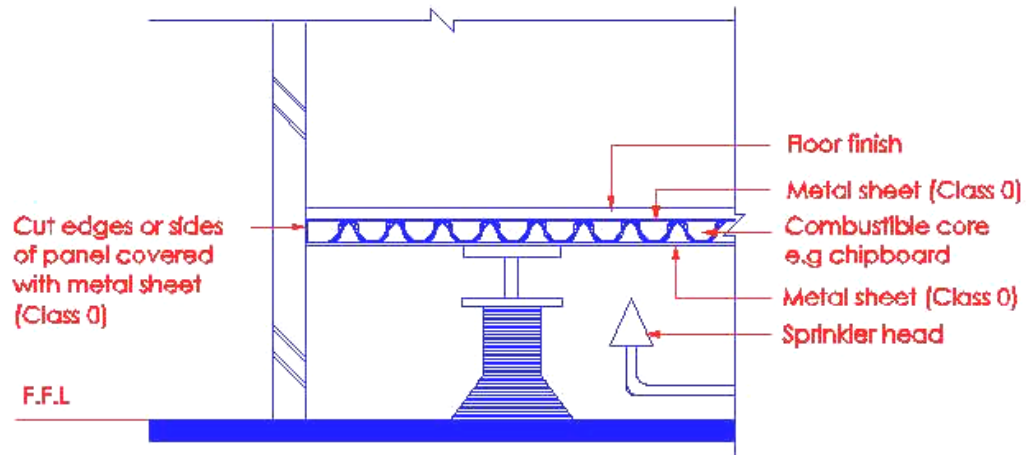

Diagram 3.11.8(e)-2

Raised floor panel constructed of combustible core, eg. chipboard, shall only be allowed to be used in buildings protected by sprinkler system and that the underside of the raised floor is adequately covered by the sprinkler system.

- (f) In the case of raised floors with accessible panels, access sections or panels shall be provided such that all concealed spaces between the structural floor and raised floor are easily accessible, and
- (g) Openings in the raised floor for entry of electrical cables shall be effectively closed to prevent entry of debris or other combustible material into the concealed spaces, and
- (h) All sides shall be properly sealed, and
- (i) The concealed space shall be sub-divided by cavity barriers such that the maximum unobstructed area within the concealed space does not exceed 930 m², and
- (j) Where the concealed space is fitted with an automatic sprinkler system which complies with the requirements in Chapter 6, cavity barriers are not required, and

- (k) The height of concealed space measured between the top of the structural floor and underside of the raised floor decking shall not exceed 400 mm and shall be fitted with automatic smoke detection system complying with requirements of SS CP 10 Code of Practice for the Installation and Servicing of Electrical Fire Alarm Systems; and in the case of sprinkler protected building, the height of concealed space may exceed 400 mm if the space is fitted throughout with an automatic sprinkler system which complies with the requirements in Chapter 6.

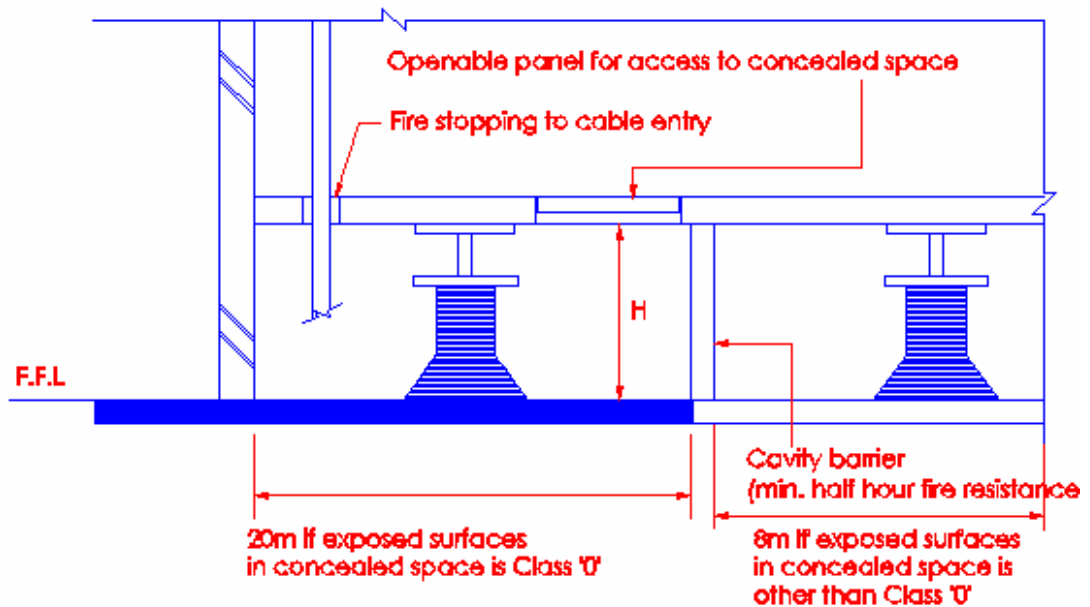

Diagram 3.11.8(g) – (k)

The provision of cavity barriers shall comply with Table 3.11A of the Fire Code.

Non-sprinkler protected building

Cavity barriers shall be provided in accordance with Table 3.11A. The height of concealed space (H), measured between the finished floor level and the underside of the raised floor decking shall not exceed 400mm. The concealed space shall be fitted with smoke detection system in accordance with SS CP 10 Code of Practice for the Installation and Servicing of Electrical fire Alarm Systems. SS CP 10 also allows that smoke detector system is not required to be provided in concealed space which does not exceed 150mm in height – cl.2.1.3.1(b). Sprinkler system is applicable if the height of concealed space exceed 400mm.

Sprinkler protected building

Cavity barriers shall be provided in accordance with Table 3.11A. Where the height of the concealed space does not exceed 400mm, smoke detection system complying with SS CP 10 shall be provided. The height of concealed space may exceed 400mm if the space is fitted throughout with sprinkler system. Where sprinkler system is provided inside the concealed space, cavity barriers are not required to be provided – subclause (j).

- (l) Where the height of concealed space measured between the top of the structural floor and the underside of the raised floor decking is less than 50mm, the requirements on provision of cavity barriers shall not be applicable.

3.11.9 Provision for concealed spaces between floor or roof and suspended ceilings

The Relevant Authority may consent to exempt from provision of cavity barriers within the concealed spaces of suspended ceiling, provided the following requirements are complied with : -

- (a) The concealed space shall not be used for storage purpose, and
- (b) The supporting elements shall be constructed of non-combustible material, and
- (c) The exposed surfaces within the concealed space is of Class 0 flame spread, (excluding surfaces of any pipe, cable, conduit or insulation of any pipe) and
- (d) In the case of a detector protected building, if the concealed space does not exceed 800 mm in depth or if the concealed space is fitted with detectors which comply with the requirements of Chapter 6.
- (e) In the case of a sprinkler protected building:
 - (i) if the concealed space does not exceed 400 mm in depth, or

- (ii) if the concealed space exceeds 400 mm and does not exceed 800 mm in depth and no combustible material is used within the concealed space, (where the combustible content is small in quantity, the Relevant Authority, may, at its discretion, rule that such combustible content may be irrelevant in relation to this sub-clause), or
 - (iii) if the concealed space is fitted with an automatic sprinkler system which complies with the requirements of Chapter 6.
- (f) In the case of other buildings, if the concealed space does not exceed 800 mm in depth.

Detector protected building (Non-sprinklered)

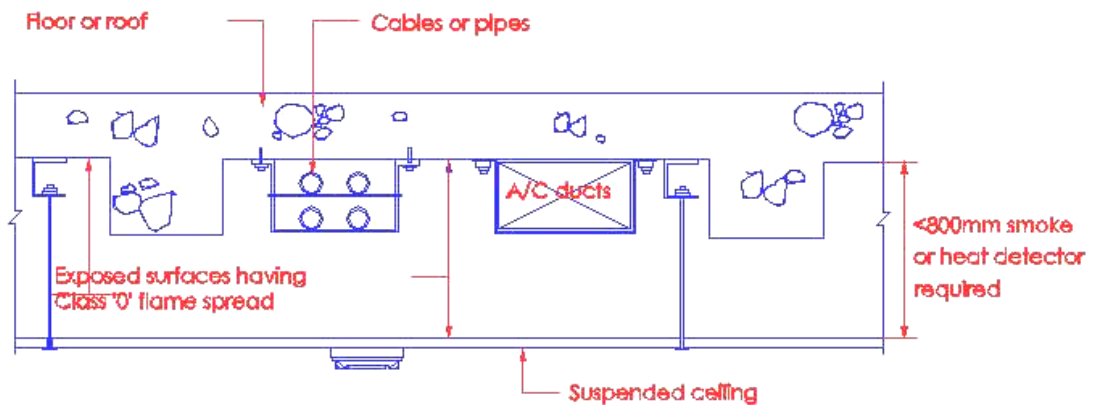

Diagram 3.11.9(d)

Provision of cavity barriers in concealed ceiling space may not be required if the following requirements are complied with :

- a) the space is not used for storage purpose; and
- b) the supporting elements eg. ceiling hangers or supports are constructed of non-combustible material; and
- c) the exposed surfaces within the concealed space is of Class 0 flame spread (excluding surfaces of any pipe, cable, conduit or insulation of any pipe or duct); and
- d) concealed space does not exceed 800mm in depth; if exceeds 800mm, it shall be fitted with smoke or heat detectors.

Sprinkler protected building - Depth of ceiling space does not exceed 400mm

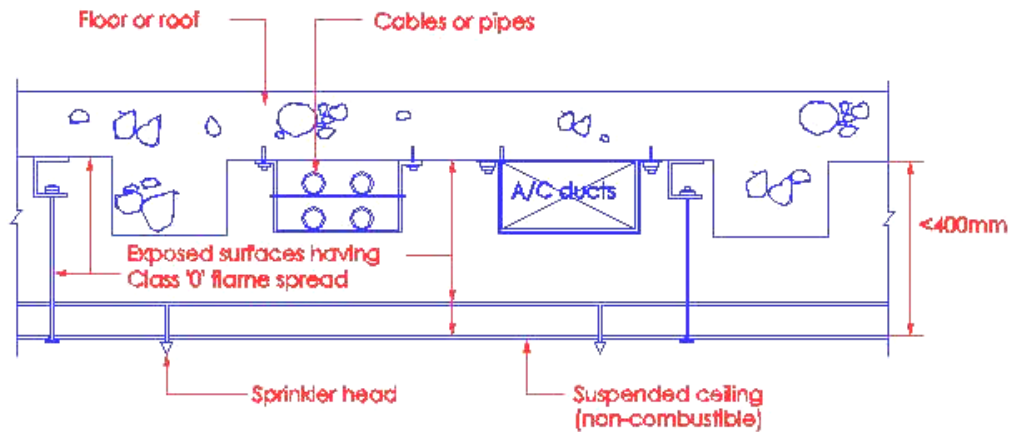

Diagram 3.11.9(e)(i)

Provision of cavity barriers in the concealed ceiling space may not required if the following are complied with :

- a) the space is not used for storage purpose; and
- b) the supporting elements eg. ceiling hangers or supports are constructed of non-combustible material; and
- c) the exposed surfaces within the concealed space is of Class 0 flame spread (excluding surfaces of any pipe, cable, conduit or insulation of any pipe or duct); and
- d) concealed space does not exceed 400mm in depth.

Sprinkler protected building - Depth of ceiling space exceeds 400mm but not exceeding 800mm

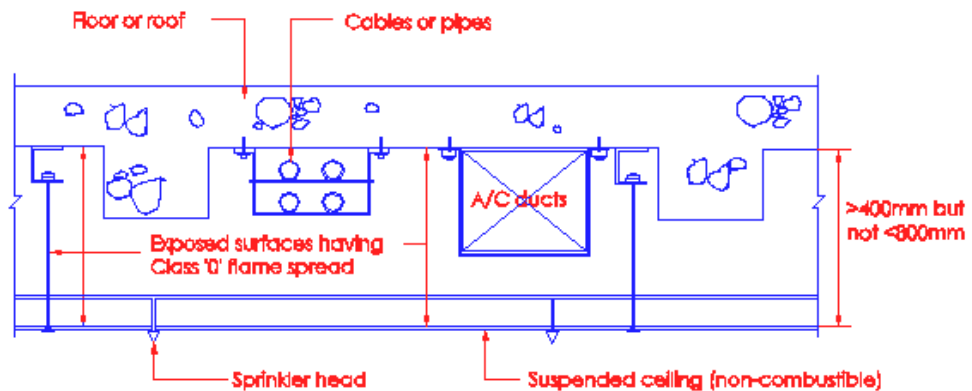

Diagram 3.11.9(e)(ii)

Provision of cavity barriers in the concealed ceiling space may not be required if the following are complied with :

- a) the space is not used for storage purpose; and
- b) the supporting elements eg. ceiling hangers or supports are constructed of non-combustible material; and
- c) the exposed surfaces within the concealed space is of Class 0 flame spread (excluding surfaces of any pipe, cable, conduit or insulation of any pipe or duct); and
- d) no combustible material is used within the concealed space. However, where the combustible content is small in quantity, FSSD may, at its discretion grants exemption, provided the space is protected by sprinklers installed on the extended basis under sub-clause 6.6.1.2 of SS CP 52. (whole coverage to be extended to the ceiling)

Concealed space is sprinklered protected – in accordance with Chapter 6

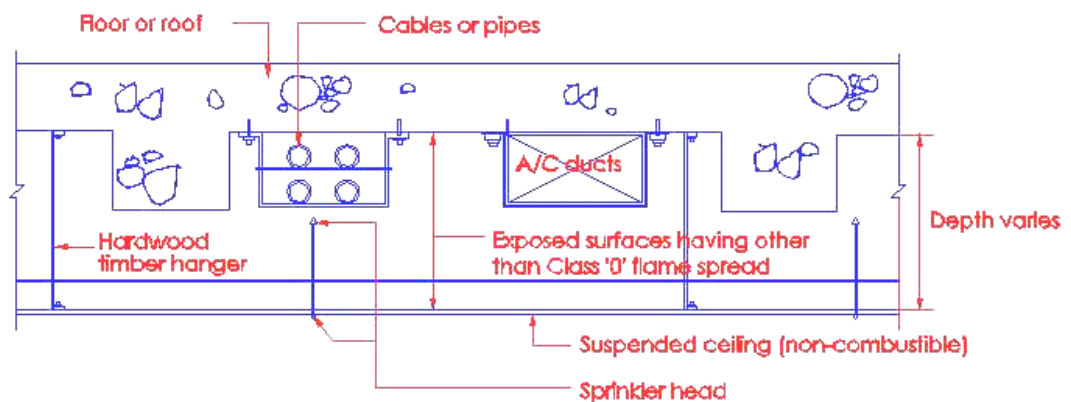

Diagram 3.11.9(e)(iii)

Provision of cavity barriers in the concealed ceiling is not required. See also cl.3.11.10 for further relaxation.

Other building – which neither requires detector nor sprinkler system

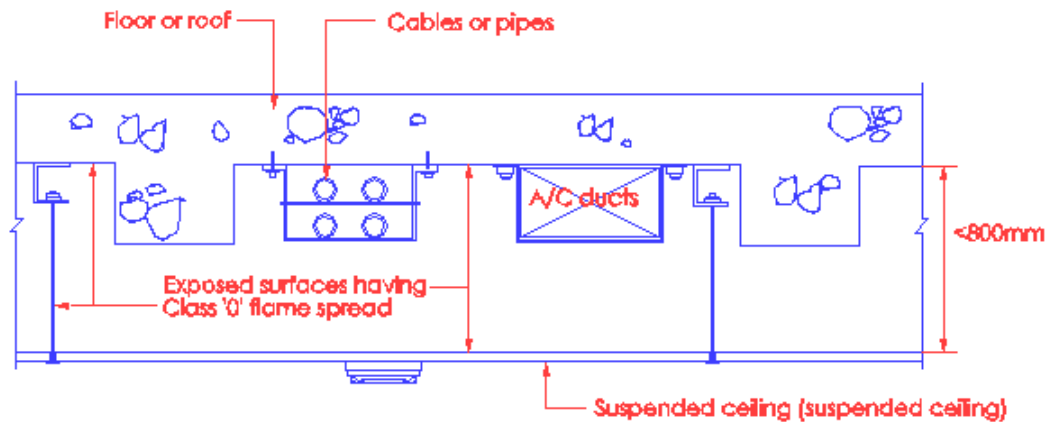

Diagram 3.11.9(f)

Provision of cavity barriers in the concealed ceiling space may not required if the following are complied with :

- a) the space is not used for storage purpose; and
- b) the supporting elements eg. ceiling hangers or supports are constructed of non-combustible material; and
- c) the exposed surfaces within the concealed space is of Class 0 flame spread (excluding surfaces of any pipe, cable, conduit or insulation of any pipe or duct); and
- d) concealed space does not exceed 800mm in depth; if exceeds 800mm, it shall be fitted with smoke or heat detectors.

3.11.10 Exemption of cavity barriers in ceiling space

Where the concealed space of suspended ceiling is fitted with an automatic sprinkler system which complies with the requirements in Chapter 6,

- (a) The concealed space may be exempted from provision of cavity barriers, and

- (b) Combustible materials and materials with other than Class 0 flame spread may be used for the supporting elements and exposed surfaces of materials within the concealed space, provided the ceiling is not situated over an exit passageway, smoke-stop lobby or other designated means of escape facilities.

(No illustration)

- i) *Where the concealed ceiling space is protected by automatic sprinkler system, the above clause allows the following :*
 - a) *Provision of cavity barrier is exempted;*
 - b) *Combustible materials such as hardwood timber hangers for ceiling; and*
 - c) *Exposed surfaces within the ceiling space may be of any class other than Class 0 flame spread ie. timber members.*
- ii) *The above relaxation shall not apply if the above ceiling construction is situated over an exit passageway, smoke-stop lobby or other designated means of escape facilities.*

3.11.11 Suspended ceiling over protected areas

The concealed spaces of suspended ceiling over an exit passageway, smoke-stop lobby, exit staircase or other designated means of escape facilities, shall comply with the following:

- (a) the ceiling supporting elements and the ceiling shall be constructed of non-combustible materials; and
- (b) the exposed surfaces within the concealed space shall be of Class 0 surface flame spread.

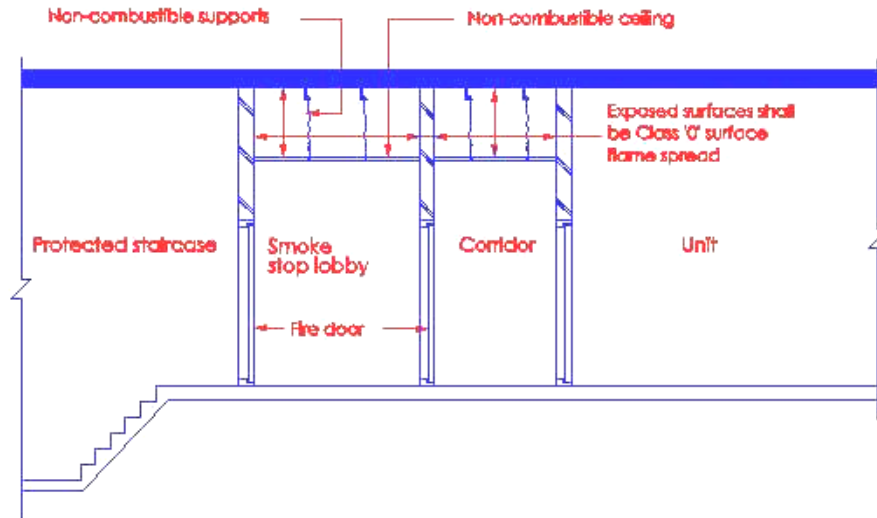

Diagram 3.11.11

The main concern is that spaces meant for safe escape of occupants shall be kept free of combustible materials. Common corridors to buildings under Purpose Group II are treated as escape routes, except those open sided 1st storey corridors directly serving the residential units. The exposed surfaces with the ceiling space shall have a flame spread rating of Class '0'.

- 3.11.11 (c) Where sprinkler system is installed within the concealed spaces at smoke stop lobby/fire fighting lobby, the ceiling supporting elements and its exposed surface may have a surface spread of flame not lower than class 2.

(No illustration)

- 3.11.12 Residential units in buildings under purpose group II need not comply with requirements on the provision of cavity barrier in concealed floor and ceiling spaces.

(No illustration)

- 3.12.1 General provision

Openings for pipes, ducts, conduits or cables which pass through any part of an Element of Structure (except for a part which does not serve as a fire resisting barrier) or Cavity Barrier shall be :

- (a) Kept as few in number as possible, and
- (b) Kept as small as practicable, and

- (c) All gaps shall be filled with fire-stopping material.

Fire stopping to a pipe
in a compartment wall

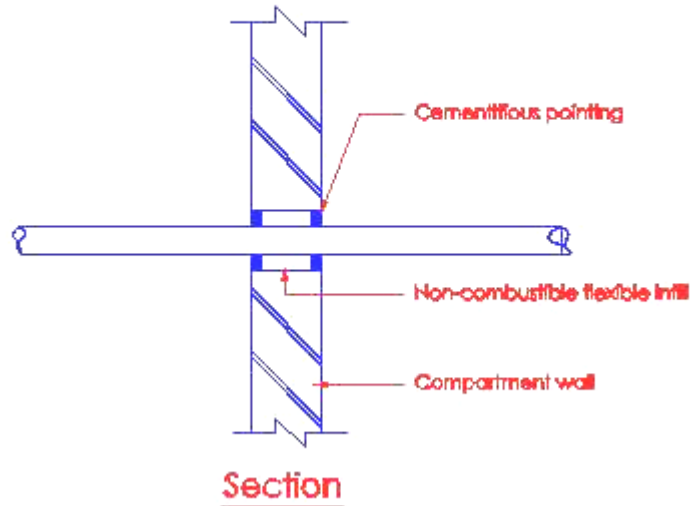

Diagram 3.12.1

Fire stopping is concerned with ensuring that the fire-resisting capability of a component ,i.e separating wall, compartment wall/floor, cavity barrier is not diminished or impaired when penetrated by services for example, a pipe, ducts etc. Therefore whenever gaps are created by the penetration of such pipes, ducts in the fire rated wall/floor, they must be kept as few as possible. The spacing and internal diameter of pipes passing through any elements of structure or cavity barrier shall comply with Cl.3.9.3 and Table 3.9A

3.12.2 Fire stopping

Fire stopping shall be of material having the necessary fire resistance when subjected to test under BS 476 Pt 20 or other acceptable standards.

(No illustration)

3.12.3 Materials for fire-stopping

Suitable fire stopping materials include:

- (a) Proprietary fire stopping and sealing systems (including those designed for service penetrations) which have been shown by test to maintain the fire resistance of the wall or other element, subject to approval by the Relevant Authority.
- (b) Other fire-stopping materials include:
 - (i) cement mortar;
 - (ii) gypsum based plaster;
 - (iii) cement or gypsum based vermiculite/perlite mixes;
 - (iv) glass fibre, crushed rock, blast furnace slag or ceramic based products (with or without resin binders), and
 - (v) intumescent mastics.

The method of fire stopping and choice of materials should be appropriate to the situation and its application.

(No illustration)

To prevent displacement, materials used for fire-stopping should be reinforced with (or supported by) materials of limited combustibility in the following circumstances:

- (i) in all cases where the unsupported span is greater than 100mm, and*
- (ii) in any other cases where non-rigid materials are used (unless they have been shown to be satisfactory by test).*

Preference should be given to proprietary fire-stopping and sealing system.

When cement mortar or gypsum board plaster or cement or gypsum based vermiculite/perlite mixes is used as fire stopping material, care should be exercised to ensure that workmen properly fill up the entire gaps with the appropriate fire stopping material instead of carrying cosmetic application by just filling up the gaps superficially.

3.13.1 Requirements for Class 0

Any reference to a surface being Class 0 shall be construed as a requirement that -

- (a) The material of which the wall or ceiling is constructed shall be non-combustible throughout; or
- (b) The surface material (or, if it is bonded throughout to a substrate, the surface material in conjunction with the substrate) shall have a surface of Class 1 and if tested in accordance with BS 476: Part 6 shall have an index of performance (I) not exceeding 12 and a sub-index (I) not exceeding 6.

(No illustration)

BS 476:Part 6 refers to a standard fire test for propagation of products.

Under this test, there is a means of comparing the contribution of combustible building materials to the growth of a fire by providing a measure of the rate of heat evolution of the samples, exposed in a small combustion chamber.

The performance of each sample is expressed as a numerical index from 0 to 100 or more. Low values of the indexes indicate a low rate of heat release. Three to five specimens are tested.

Index of performance $I = i_1 + i_2 + i_3$ where sub-index i_1 is derived from the first three minutes of test, i_2 from the following seven minutes, and i_3 from the final ten minutes. A high index i_1 indicates an initial rapid ignition and heat release.

3.13.2 Requirements for a class other than Class 0 classification

Any reference to a surface being of a class other than Class 0 shall be construed as a requirement that the material which the wall or ceiling is constructed shall comply with the relevant test criteria as to surface spread of flame specified in relation to that class in BS 476: Part 7.

(No illustration)

Test under BS 476: Part 7 refers to a standard fire test for the classification of the surface spread of flame of products.

This test is able to determine the tendency of surfaces of flat materials to support the spread of flame across their surfaces and specifies a method of classification appropriate to wall and ceiling linings. Class 1 represents the best performance, followed in descending order by Class 2, Class 3 and Class 4.

3.13.3 Class 0 shall be regarded as the highest class followed in descending order by Class 1, Class 2, Class 3 and Class 4, as set hereunder:

- * Class 0 - Surface of no Flame Spread. Those surfaces that conform to the requirements of Cl. 3.13.1.
- * Class 1 - Surface of Very Low Flame Spread. Those surfaces on which not more than 150mm mean spread of flames occurs under the relevant test conditions.
- * Class 2 - Surface of Low Flame Spread. Those surfaces on which during the first 1-1/2 minutes of test, the mean spread of flame is not more than 375 mm and the final spread does not exceed 450 mm under the relevant test conditions.
- * Class 3 - Surface of Medium Flame Spread. Those surfaces on which during the first 1-1/2 minutes of test, the mean spread of flame is not more than 375 mm and during the first 10 minutes of test is not more than 825 mm under the relevant test conditions.
- * Class 4 - Surface of Rapid Flame Spread. Those surfaces on which during the first 1-1/2 minutes of test the mean spread of flame is more than 375 mm and during the first 10 minutes of test is more than 825 mm under the relevant conditions.

(No illustration)

The reason for having Class 0 is that Class 1 covered too wide a range of performance for use in critical areas. Where a higher degree of protection is required, for example in smoke stop lobbies, exit staircases, exit passageways (which constitute the escape route), Class 0 is specified.

3.13.4 Class of flame spread to be not lower than specified

The surface of a wall or ceiling in a room/space shall be of a class not lower than specified as relevant in the Table 3.13A, provided that -

- (a) Where an automatic sprinkler system is fitted throughout in the building in compliance with the requirements in Chapter 6, there is no control on the surface of flame rating in room / space, except for the following occupancies / usage:

(iii) Exit staircase, exit passageway and smoke-stop / fire fighting lobbies.

(b) Where a building is not protected by automatic sprinkler system, surfaces of the walls and ceilings may be of a surface class not lower than class 3 to the extent permitted by Cl 3.13.5 (a) and Cl 3.13.5 (b) respectively.

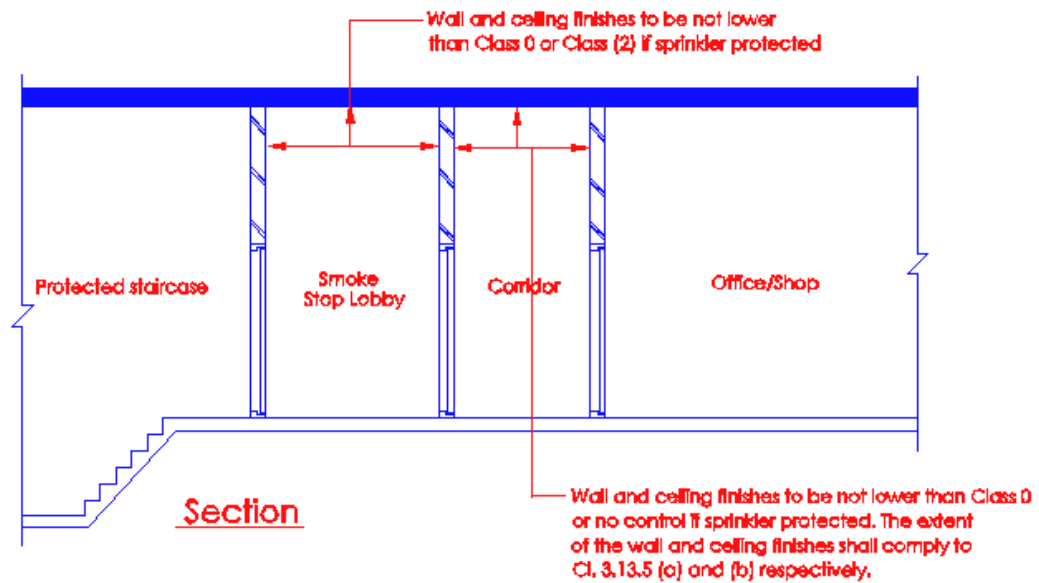

Diagram 3.13.4

Wall, ceiling and floor finishes to exit staircase (including exit passageway) shall be of non-combustible materials or Class 0 (sprinkler protected). For rooms, the extent of wall and ceiling finishes shall comply to Cl.3.13.5 (a) and (b) respectively.

3.13.5 (a) Where class of flame spread may be of any class not lower than class 3

Any part of the surface of a wall in a room or compartment may be of any class not lower than Class 3 if the area of that part (or if there are two or more such parts, the total area of those parts) does not exceed the following -

(i) in the case of a building or compartment of purpose group II, 20 m²

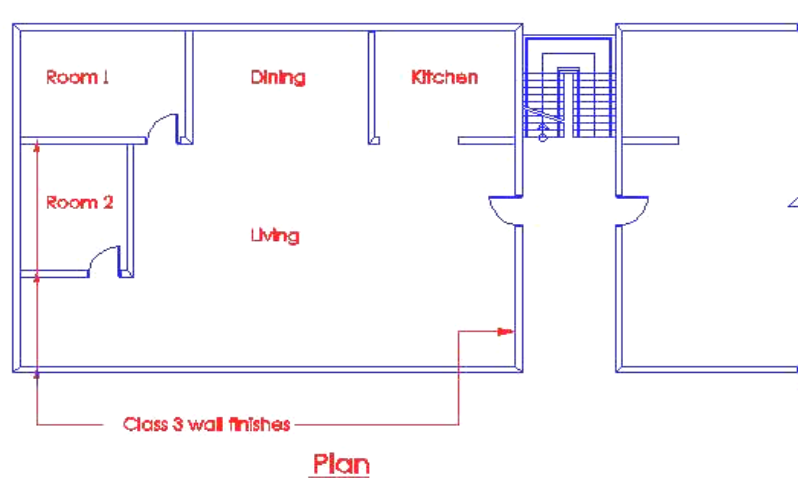

Diagram 3.13.5

The aggregate area of combustible finishes to walls in room 1, room 2 and living/dining room shall not exceed 20m² of any class not lower than Class 3. "Room" in the above sub-clause refers to a fire compartment as in the above case, an apartment unit or a floor of a building if that floor is a compartment by itself.

- (b) Any part of the surface of a ceiling may be of any class not lower than Class 3 if that part of the surface is the face of a layer of material the other face of which is exposed to the external air (skylight included) and -
- (i) * the ceiling is that of a room in a building or compartment of Purpose Group II or that of a circulation space excluding smoke-stop lobby, exit staircase and exit passageway in a building or compartment of any purpose group, and
 - * the area of that part does not exceed 2.5 m², and
 - * the distance between that part and any other such part is not less than 3.5 m, or
 - (iii) that part and all other such parts are evenly distributed over the whole area of the ceiling and together have an area which does not exceed 20% of the floor area of the room, or

- (iv) the ceiling is that of a balcony, verandah, open carport, covered way or loading bay which (irrespective of its floor area) has at least one of its longer sides wholly and permanently open, or
- (v) the ceiling is that of a garage or outbuilding which (irrespective of whether it forms part of a building or is a building which is attached to another building or wholly detached) has floor area not exceeding 40 m².

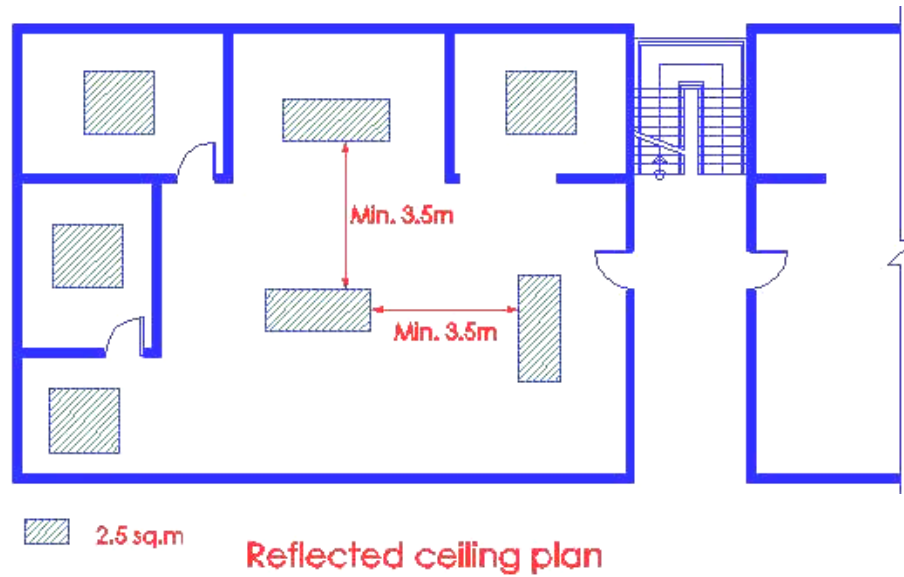

Diagram 3.13.5(b)(i)

Ceilings of living room, dining room, kitchen and bedrooms are permitted to have combustible finishes of class not lower than Class 3. The control is based on the size and spacing of the ceiling material.

3.13.6 Exception

Wall and ceiling finishes in the form of thin sheet of not more than 1.0 mm thickness mounted on a non-combustible substrate will not be subject to the requirement of surface spread of flame provisions provided that this exception shall not apply to smoke-stop / fire fighting lobbies, exit staircases and passageways.

(No illustration)

The above clause grants relaxation on the control of wall and ceiling finishes which are not more than 0.8mm thick mounted on non-combustible substrate, provided these finishes are not used in smoke-stop lobbies, exit staircases and exit passageways. The main concern is that all protected routes meant for escape of occupants shall be kept free of combustible finishes.

3.14.1 Roof construction

Surface of materials for roof covering and roof construction shall have a surface spread of flame rating not lower than class 1, except in the case of purpose group II, and in buildings that are protected throughout with automatic sprinkler system in compliance with Chapter 6.

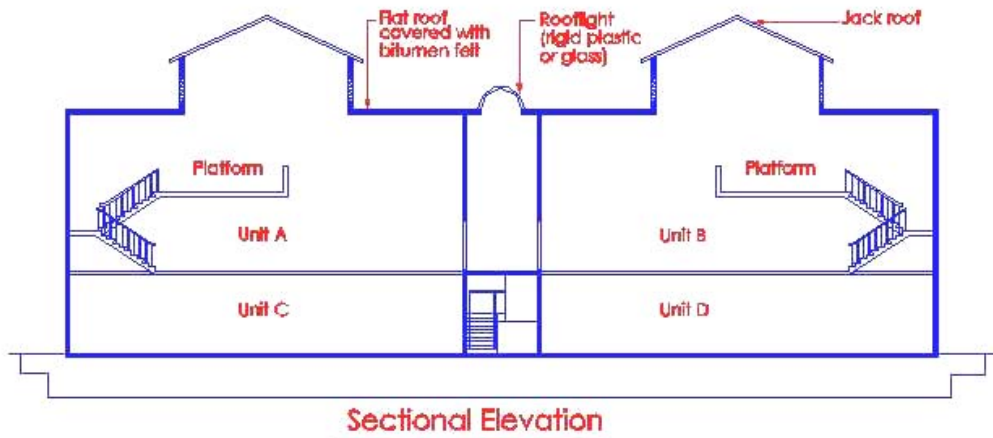

Diagram 3.14.1

Roofs of building under Purpose Group II may consist of dome, flat, pitched roof and other types. Roof covering may include mixture of combustible and non-combustible materials, e.g slate, clay tiles, glass, rigid plastic. It is quite common to find hardwood timber trusses, purlins etc being used in the roof construction. The term "roof covering" is used to describe construction which may consist of one or more layers of material, but does not refer to the roof structure as a whole. Roofs which may have different construction can be broadly grouped under the following:

- a) Roofs over common corridors and means of escape. As these areas are meant for escape, it would be preferable that they be constructed totally of non-combustible materials.
- b) Roof over apartment/maisonette or penthouse units.
- c) Roof over linkway between buildings.
- d) Roof used as terrace or floor open to sky. The roof covering should be of non-combustible materials to eliminate any fire risk arising from a fire involving the covering.
- e) Roof over balconies

Roof can also perform two functions:

- a) to contain a fire or prevent its penetration from an external source; and
- b) to ensure that the external covering does not contribute to spreading of fire so that an adjoining roof might be in danger.

RC roof would be able to satisfy the above functions. However, traditional roof coverings such as tile, slates, metal roofing sheets etc, combined with timber trusses/purlins and combustible insulation materials would have a greater tendency to allow spread of flame. Rigid plastic or thermo – plastic materials such as polycarbonate shall not be used. Similarly, thatched roof shall also not be used. Traditionally, tile roof construction requires timber battens and purlins for securing the tiles. However, the risk of fire spread via such timber members is taken care of by the provision of separating wall between residential units.

3.14.3 Roof junction with separating wall and compartment wall

At the junctions with separating wall or compartment wall, roof construction shall comply with the relevant requirements under Cl.3.6.3 and Cl.3.7.4 respectively.

(See illustration and comments under Cl.3.6.3)

3.14.4 Roof terrace

Roof terrace shall not be roofed over. If it is either partially or fully roofed over, it shall be considered as a habitable floor.

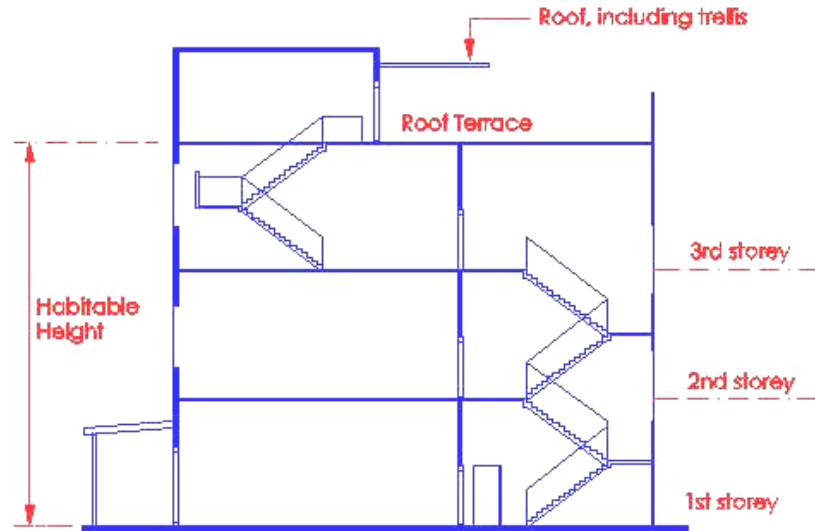

Diagram 3.14.4

Roof Terrace

a) Means of escape

Roof terrace even if not roofed over could be used by building owners to hold private functions. In this respect, the roof terrace would attract additional occupant load, which could be sizeable, depending on the type of function proposed, for example, a private dinner function could be held on the open roof terrace. The guests and the hosts that are attending the private function on the roof terrace would be subject to the risk of a fire that could break out in any of the floor space below the roof terrace. For this reason, roof terrace, whether roof over or not should be subjected to compliance with exit capacity and travel distance requirements under the fire code. Roof terrace which exceeds the floor area of 60sq. m shall be provided with a separate exit at terrace level.

b) Habitable height

For the purpose of determining the habitable height of a building, roof terrace that is either partially or fully roofed over shall be considered as a habitable floor. Thus, if the roof terrace is the highest habitable floor, the habitable height of a building shall be measured from the lowest level of the fire engine access road to the finished floor level of the highest habitable floor.

In the above diagram, the habitable height of the building shall be measured up to the finished floor level of the terrace. Otherwise it shall be measured up to the finished floor level of the 3rd storey.

3.15.1 (a) Materials used in the construction of building elements shall comply with the provisions stated under this section in addition to the performance requirements such as for fire resistance and limit to spread of flame as stipulated in other relevant sections of the code.

3.15.1 (b) Intumescent Paints

Intumescent paints is allowed to be used for protection of structured steel members of all buildings, to achieve the required fire resistance, provided :

- (i) the paint shall be of a proprietary system that has been demonstrated to achieve the fire resistance performance as required in BS 476 Part 20/21 or its equivalent, together with the specified weathering tests as specified in the BS 8282: Part 2 – 1992;
- (ii) they shall be used to protect structural beams only, excluding load transfer beams, if the habitable height of the building exceeds 24m.
- (iii) coating of intumescent paint onto structural steel, and subsequent maintenance shall conform to BS 8202: Part 2: 1992; and
- (iv) all requirements stipulated in the Appendix to this clause: "Notes on the use of Intumescent Paints for Protection to Structural Steel Members of Buildings" shall be complied with. (Please see Appendix (F))

(No illustration)

Flame retardant chemicals are permitted to be used for upgrading of fire resistance rating or surface spread of flame of timber or any combustible materials, subject to the following:

- (i) The chemical treatment process is part and parcel of the manufacturing process to produce the finished product ;

- (ii) The chemical treatment is by means of pressure impregnation conforming to SS CP: 1 – Use of Timber in Building Construction , or the manufacturer's specification in accordance to the prototype test, for timber and other combustible materials respectively.
- (iii) The treated materials/products have been subjected to fire test as required under Cl 3.4.1 or Cl 3.13.1

(No illustration)

- 3.15.2 All elements of structure shall be constructed of non-combustible materials in addition to the relevant provisions as follows:
- Cl.3.3 for fire resistance of elements of structure,
Cl.3.5.1, 3.5.2 & 3.5.4 for External Walls,
Cl.3.6.1(c)/(d) & 3.6.5 for Separating Walls,
Cl.3.7.1(c)/(d), 3.7.5 & 3.7.6 for Compartment Walls and Compartment Floors,
Cl.3.8.2(c), 3.8.4, 3.8.7(c), 3.8.8(b), 3.8.8(e) and 3.8.9(a) for Protected Shafts.
- 3.15.3 Materials used for the protection of openings shall comply with the relevant provisions of cl.3.9 of the code for protection of openings.
- 3.15.4 Exit staircases shall be constructed of non-combustible materials to comply with the provision of Cl.3.10.1.
- (See Cl.3.10.1 to 3.10.4 for illustration and explanation)*
- 3.15.5 Materials used for the construction of raised floors shall comply with the provisions of cl.3.11.8(a) and cl.3.11.8(e).
- 3.15.6 Materials used for construction of ceiling and its supports shall comply with Table 3.13B, except for supports that are required to comply with cl.3.11.9 (b).
- 3.15.7 Construction of ceilings and ceiling supports located within sprinkler protected building shall comply with the provision of cl.3.11.10(b).
- 3.15.8 Materials used for fire stopping shall comply with the relevant provisions of cl.3.12.2 and 3.12.3.

- 3.15.9 Materials used on the surfaces of walls and ceilings are required to meet the requirements for restriction of spread of flame and to comply with the performance requirements as stipulated under cl.3.13.
- 3.15.10 Materials used for roof construction shall comply with the provisions of cl.3.14.1.
- 3.15.11 Internal non-load bearing walls in buildings shall comply with Table 3.13B and the materials for surface finishes of internal non-load bearing walls shall not be treated as part of the wall and shall comply with the relevant provisions of cl 3.13.

(No illustration)

All the internal non-load bearing walls in the residential units shall be constructed of non-combustible materials. Materials for surface finishes of all the walls, non-loading bearing, separating and compartment walls shall comply with Cl. 3.13.5 and Cl. 3.13.6.

- 3.15.12 (a) Composite panels which consist of plastic core shall not be used either for the construction of internal non-load bearing walls, ceilings, external walls or as cladding to external walls of all buildings unless prior approval has been obtained from the Relevant Authority.

(No illustration)

Composite panels are used as external walls or cladding of external walls to buildings. Prior approval should be obtained before any composite panel is erected on site. The main concern is that composite panels when subjected fire would burn vigorously to produce thick, poisonous fumes.

- (b) Materials with surface flame spread rating of not lower than Class 3 shall be permitted to be used for the construction of partition for toilet cubicles. If the material used is of Class 3 surface flame spread rating, total exposed surface area of the partitions within the toilet shall not be more than 60m².



Diagram 3.15.12 (b)

Materials with surface flame spread rating of not lower than Class 3, including phenolic panels, are allowed to be used in the construction of partitions for toilet cubicles only.

The exposed surface area of not more than 60m² of the partitions within the toilet refers to the surface exposed to air, inside and outside, of the partitions.

The reasons for allowing materials with surface flame spread rating of not lower than Class 3, including phenolic panels, in the construction of toilet cubicles are:-

- a. toilets are considered as wet areas;*
- b. the amount of combustible materials would be limited;*
- c. the toilets are subjected to low transient occupancy.*

Amended on 4th Feb 2004

- 3.15.13 Fire rated glass wall/door to compartment walls, compartment floors, smoke stop lobby and fire fighting lobby, and protected shafts not containing exit staircase and fire lift.

In buildings which are protected by an automatic sprinkler system, fire rated glass can be used for the construction of compartment walls, compartment floors, enclosures to smoke stop lobby and fire fighting lobby, and protected shafts not containing exit staircase and fire lift, subject to the following:

- (a) The walls and doors shall have the necessary fire resistance, including insulation, when subject to test under BS 476: Part 20-23; and
- (b) The walls and doors shall meet the class A of the Impact Performance requirements when subject to test under BS 6206 or AS 2208.

3.15.14 Internal non-load bearing walls, ceilings and finishes shall not contain any plastic material.