

## Chapter 3

### STRUCTURAL FIRE PRECAUTIONS

#### 3.1 GENERAL

3.1.1 The purpose of this chapter of the Code is to stipulate requirements to minimise the risk of spread of fire between adjoining buildings by separation, prevent the untimely collapse of buildings in the event of fire by the provision of a stable and durable form of construction and prevent the spread of fire between specified parts of the buildings by the division of such buildings into compartments.

*Structural fire precautions relate to the integrity and stability of building elements during fire for a required period of time. "Structural" does not only apply to the structural elements of buildings but other building components, e.g. doors, shafts, walls/ceiling finishes.*

*The objectives of structural fire precautions are :*

- (a) *To unload the spread of fire between adjoining buildings by adequate separation;*
- (b) *To prevent the untimely collapse of building, including walls and floors of each unit in the event of a fire*
- (c) *To prevent spread of fire from one unit to another within the building envelope by compartmentalising each unit with walls, floors and doors having the requisite fire resistance rating.*

3.2.4. (d) Single household dwelling

Buildings may consist of more than 3 floors if they are occupied as a single household dwelling.

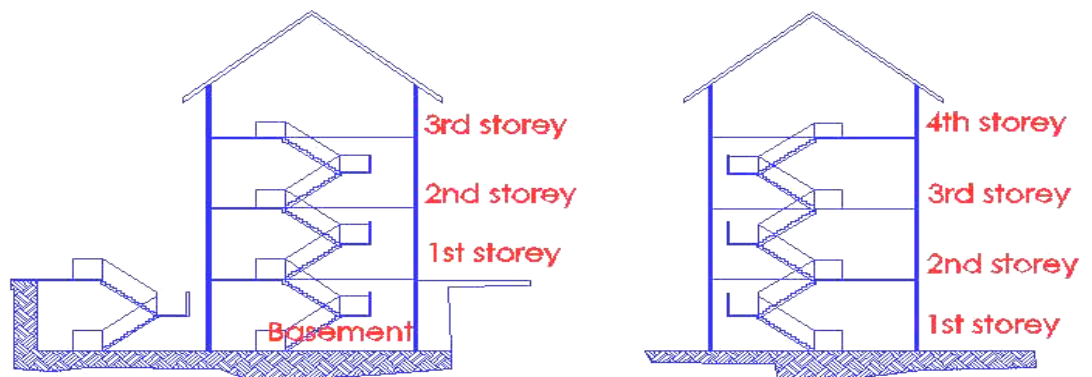

4 storeys or levels form one compartment

Diagram 3.2.4(d)

Building having 4 stories or levels under Purpose Group I are permitted. The above relaxation was introduced in 13 June 1996 to take into consideration of proliferation of 4-level purpose group I buildings due to the sudden surge in the public demand for two storey conventional houses with an attic and basement.

FSSD reviewed the above matter and issued a circular on 14 Dec 1999 to allow buildings under purpose group I to have more than 3 storeys or floors if they are occupied as a single household dwelling without the need to provide automatic fire system or external staircase.

### 3.2.5

Other cases requiring compartment wall & compartment floors

The following situations shall require compartmentation by provision of compartment walls and/or compartment floors.

- (c) Any floor immediately over a basement storey if such storey -
  - (i) forms part of a building which has five or more storeys (including the basement storey)

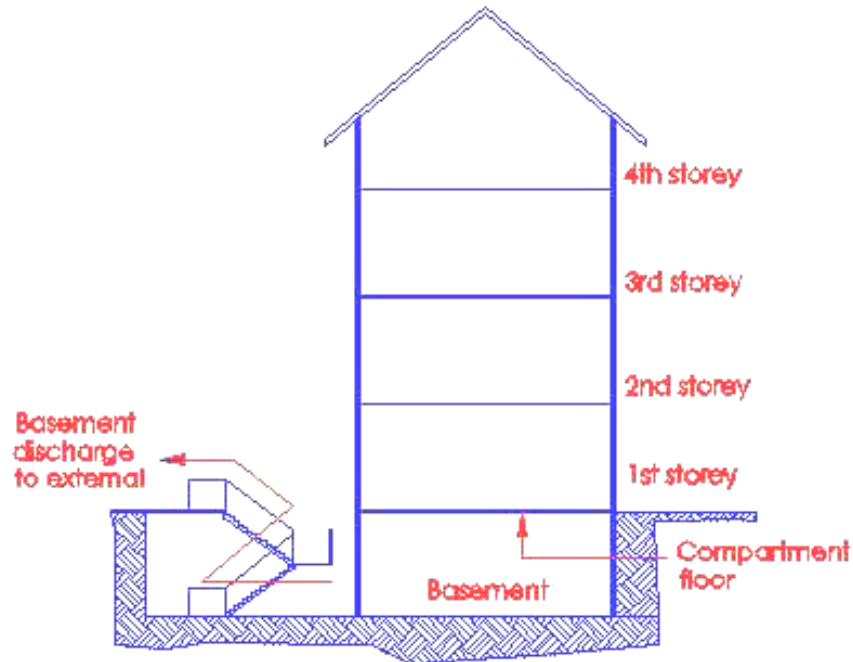

Diagram 3.2.5 - (c)

#### Floor over a basement

Any floor immediately over a basement storey if such storey forms part of a building of purpose group I which has five or more storey (including the basement storey), shall be constructed as a compartment floor, ie horizontally separating the upper storeys from the basement. The exit staircase serving the basement shall be made to discharge into the exterior at grade level.

3.2.5

(m) Coldroom

(ii) Provision of the fire resisting outer layer enclosure, including the fire door, to the coldroom would not be required if :

\* The coldroom is located in a building under purpose group I.  
(No illustration)

3.3.1

Minimum periods of fire resistance

Subject to any expressed provision to the contrary, any element of structure shall be constructed of non-combustible materials and to have fire resistance for not less than the relevant period specified in Table 3.3A having regard to the purpose group of the building of which it forms a part and the dimensions specified in that Table, provided that -

(a) Any separating wall shall have fire resistance of not less than 1-hour, and to take diagrams and explanatory notes from hand book

*Single storey residential building as provided for under Table 3.3A needs to have minimum half-hour fire resistance rating for all elements of structure irrespective of the floor area. All elements of structure shall be constructed of non-combustible materials unless otherwise permitted as in the construction of attic.*

Houses not more than 3-storey

*Table 3.3A Part 1 provides for residential building. Residential buildings having not more than 3 storeys or levels, including basement or attic, shall be provided with minimum period of fire resistance rating of half-hour for all elements of structure forming the ground or upper storey and 1-hour for the basement storey. If the basement storey has a floor area not exceeding 50m<sup>2</sup>, the period of fire resistance rating for the elements of structure can be reduced to half-hour.*

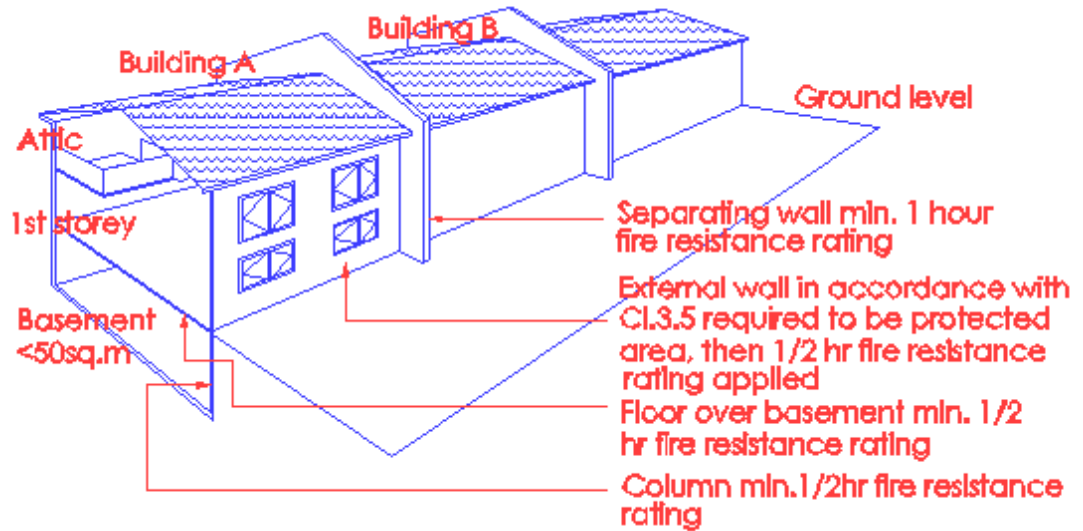

Fire resistance to columns, beams, floors and external wall

Diagram 3.3.1

Footnote(a) to Table 3.3A allows the period to be half an hour for elements forming part of a basement storey which has an area not exceeding 50 sq.m to houses having not more three storey.

Houses having 4 storeys

For buildings in which each storey does not exceed 250m<sup>2</sup>, the minimum period of fire resistance rating for elements of structure forming part of:

- a. a ground storey or upper storey - 1 hour (this period can be reduced to half-hour for floor which is not a compartment floor, except the beams which support the floor or any part of the floor which contribute to the structural support of the building as a whole).
- b. basement storey - 1 hour.

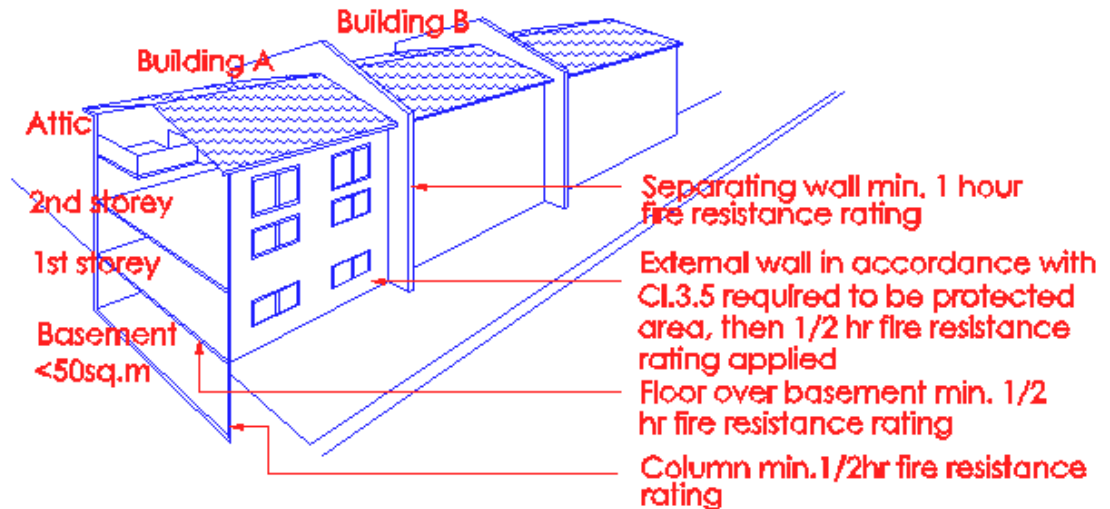

Where the floor of each storey in the building exceeds 250m<sup>2</sup>, all the elements of structure for basement and above ground shall have min. 1 1/2 hour and 1 hour fire resistance rating respectively.

Diagram 3.3.1 – (b)

### 3.3.3 Exemption for single storey buildings

In the case of a single storey building or a building consisting of a first storey and one or more basement storeys, nothing in Cl. 3.3.1 shall apply to any element of structure which forms part of the first storey and consists of :

- A structural frame or a beam or column, provided that any beam or column (whether or not it forms part of a structural frame) which is within or forms part of a wall, and any column which gives support to a wall or gallery, shall have fire resistance of not less than the minimum period, if any, required by this code for that wall or gallery, or
- An internal loadbearing wall or a loadbearing part of a wall, unless that wall or part of it forms part of a compartment wall or a separating wall, or forms part of the structure enclosing a protected shaft or supports a gallery, or
- Part of an external wall which does not support a gallery and which may, in accordance with Cl. 3.5 be an unprotected area.

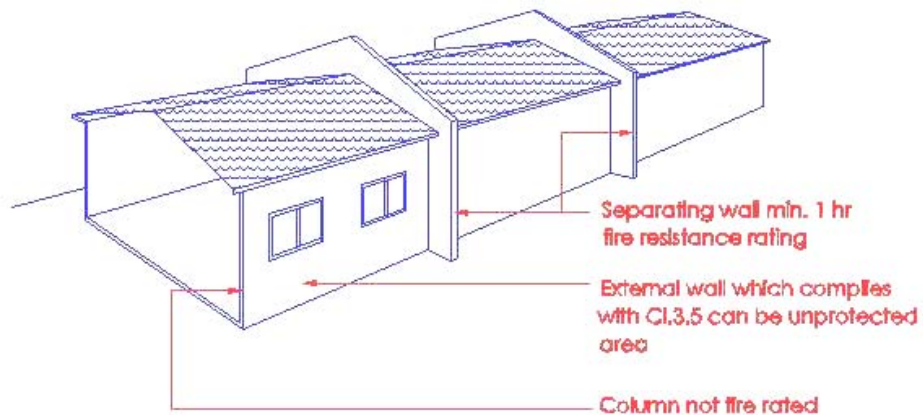

Diagram 3.3.3

### Single storey building with or without basement

#### Exemption for Single Storey Buildings

Irrespective of floor area, the minimum period of fire resistance rating for elements of structures is half-hour. However, clause 3.3.3 of the Fire Code 2002 provides exemption for single storey buildings which need not comply with half-hour fire resistance rating for the structural frame or beam or column subject to:

- a. the beams or columns are not supporting a wall or gallery;
- b. the beams or columns are not forming part of the separating wall between houses;
- c. the external walls including the supporting beams or columns which are not supporting a gallery or in accordance with cl.3.5 be an unprotected area.

#### 3.3.4

The interpretation and application of Cl. 3.3 shall be as follows:

- (d) If any element of structure is required to be of non-combustible construction, the measure of fire resistance rating shall be determined by the part which is constructed wholly of non-combustible materials. (With the exception of fire protecting suspended ceilings, surface materials for walls and ceilings and floor finishes may be combustible, if they are not relied on to contribute to the fire resistance of the wall or floor).

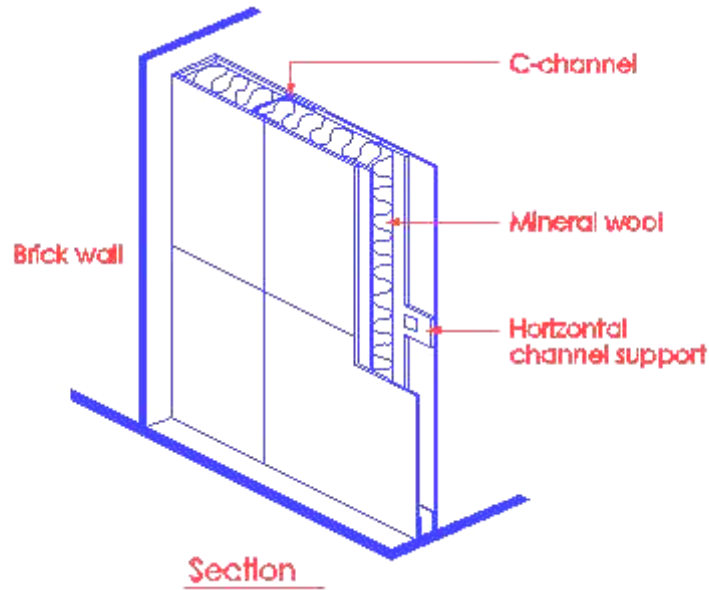

Diagram 3.3.4(d) - 1

The above diagram shows the construction of a non-load bearing fire rated compartment wall. If the C-channels or horizontal channel supports are replaced with timber members, the construction would not meet the requirement of the above subclause, as timber members are combustible. However, combustible finish if added to the surface of the wall would be considered as acceptable, provided it complies with Cl.3.13.

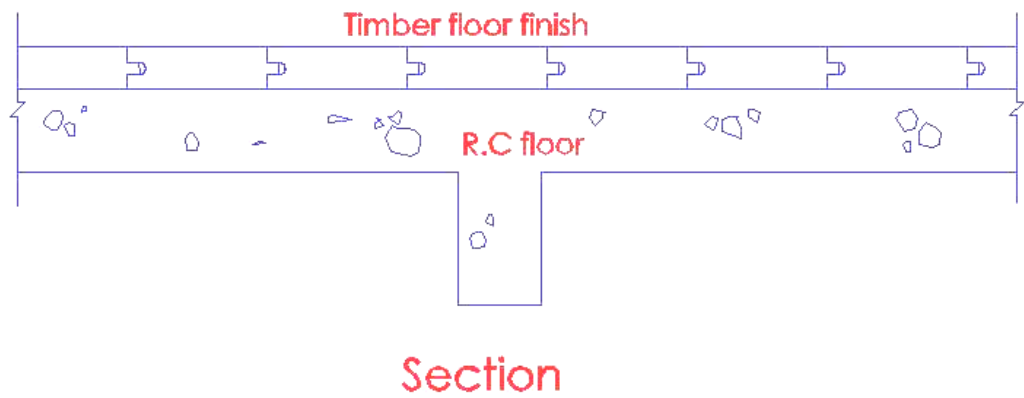

Diagram 3.3.4(d) - 2

The above diagram shows the addition of timber floor finish to the R.C floor. The combustible floor finish is not to be considered as contributing to the fire resistance of the floor.

For fire protection to suspended ceilings see cl. 3.3.6. The above clause is also not applicable to buildings under preservation or conservation where structural timber members are required to be retained. See also cl. 3.4.3.

### 3.3.6

### Suspended ceiling

In determining the fire resistance of floors, no account shall be taken of any fire resistance attributable to any suspended ceiling unless the ceiling is constructed specifically as a fire protecting suspended ceiling and the construction complies with the requirements under Table 3.3B for Limitations on Fire Protecting Suspended Ceilings.

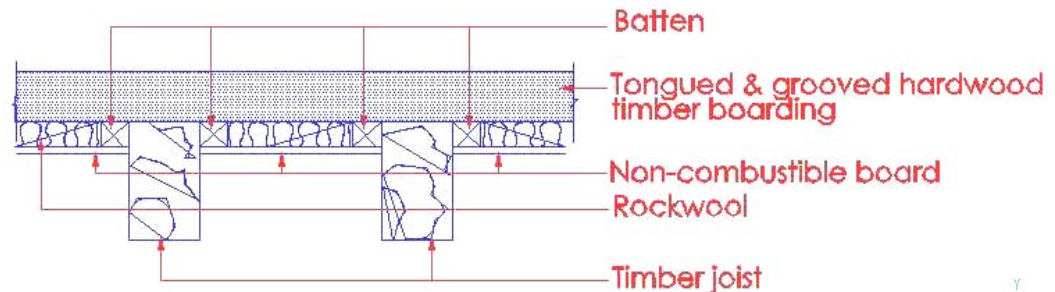

Diagram 3.3.6-1

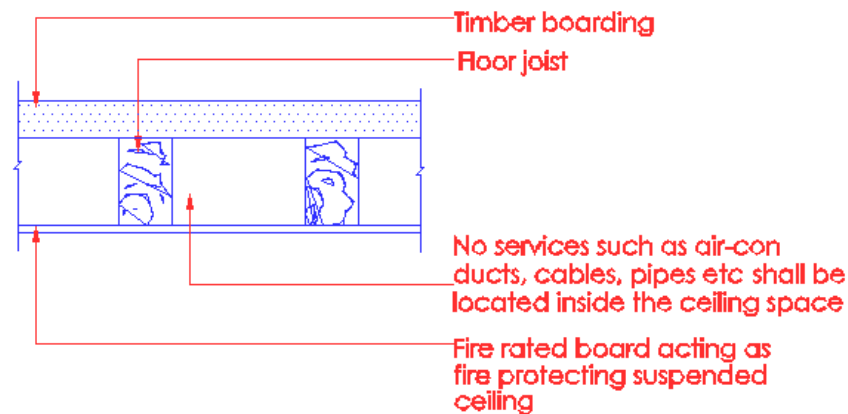

Diagram 3.3.6-2

The suspended ceiling is to be treated as the soffit as the floor system or assembly consists of the timber boarding, joists and the suspended ceiling to achieve the necessary fire resistance rating.

Therefore the concealed space in the floor system or assembly is to be treated differently from concealed spaces mentioned under Cl.3.11. The main different is that concealed spaces in floor system or assembly are not permitted to have services such as air-con ducts, cables, pipes etc; even if these services are housed in fire rated enclosures.



### 3.3.7

#### Fire rated board

- (i) Material shall be non-combustible (BS476 Pt 4 or Pt 11); and
- (ii) It shall have fire resistance for not less than the relevant period specified in Table 3.3A having regard to the purpose group of the building of which it forms a part and the dimensions specified in that Table; and
- (iii) It shall meet the criteria, in terms of water absorption and bending strength performance, when subject to test of BS1230 Pt 1 (for gypsum plaster board) or ISO 1896 (for calcium silicate or cement board); and
- (iv) The fire rated boards shall be constructed to be in contact with the steel column. If it is unavoidable, the void space between the fire rated board and the steel column shall be adequately filled to a height of 1.2m, measured from finished floor level, with fire protective material such as concrete, gypsum or grout to prevent any possible denting of the boards; and
- (vi) There shall be no services running in the space between the steel structure and fire rated boards, unless these services are encased in concrete or run in steel conduits.

Note : Fire rated boards should not be used to protect structural steel in areas which may be subject to explosion risks as the boards may be displaced by the force of the blast  
(No illustration)

## 3.4

### Test for Fire resistance

#### 3.4.1

Performance for the fire resistance of elements of structure, doors and other forms of construction shall be determined by reference to the methods specified in BS 476:Part 20 to 23, which specify tests for stability, integrity and insulation.

Specific requirements for each element in terms of the three performance criteria of stability, integrity and insulation are given in Table 3.4A.

In conjunction with Part 20, methods of test are provided for – Beams, columns, floors, flat roofs and walls(Part 21); Partitions, doorsets and vertical shutter assemblies, ceiling membranes and glazed elements(Part 22); and Suspended ceilings protecting steel beams and intumescent seals for use in conjunction with single acting latched timber fire-resisting door assemblies(Part 23).

Part 20 specifies standard heating conditions based on a temperature/time curve (Diagram 3.4.1) which furnaces are required to follow; the temperature at defined locations close to the exposed face of the specimen under test rising to 821°C after 30 minutes and 1133°C after four hours.

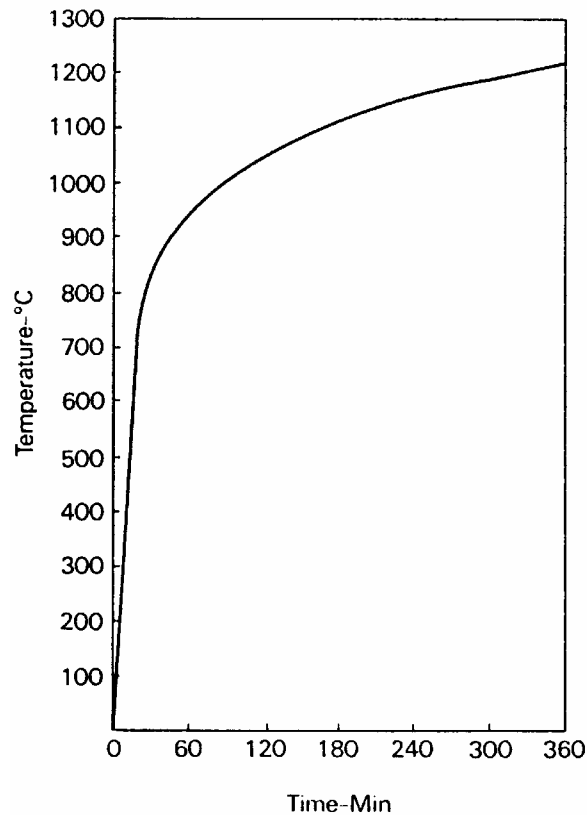

*Standard temperature/time curve (BS 476: Part 20 )*

*The specimen to be tested should be either full size or, where the element exceeds the size that can be accommodated by the furnace, it must have the following minimum dimensions.*

*Non-separating elements:*

*Vertical 3m high  
Horizontal 4m span*

*Separating elements:*

*Vertical 3m high X 3m wide  
Horizontal 4m high X 3m wide*

*Specimens are normally heated to simulate their exposure in a fire, eg walls from one side, floors from beneath and columns from all sides.*

Elements of building construction are required to satisfy various criteria according to their designed function in the event of fire. These are:

<i>“Stability” or “Loadbearing capacity”</i>	<i>the ability of a loadbearing element to support its test load without excessive deflection;</i>
<i>“Integrity”</i>	<i>the ability of a separating element to resist collapse, the formation of holes, gaps or fissures through which flames and/or hot gases could pass, and the occurrence of sustained flaming on the unexposed face (the side of the specimen remote from the furnace)</i>
<i>“Insulation”</i>	<i>the ability of a separating element to resist an excessive rise in temperature on its unexposed face.</i>

*The criterion of “stability” or “loadbearing capacity” is applied only to loadbearing elements. For floors, flat roofs and beams, allowable vertical deflection is limited to 1/20 clear span.*

*Loss of “integrity” in the context of the formation of holes, gaps or fissures is judged by ignition of a cotton fibre pad. Where this test is not suitable, failure is deemed to have occurred if either a 25mm diameter gauge can penetrate into the furnace through a gap at any point, or a 6mm diameter gauge can penetrate into the furnace through an opening and can be moved for a distance of at least 150mm.*

*Loss of “insulation” occurs when the temperature on the unexposed face (the side of the specimen remote from the furnace) increases by more than 140°C (mean) or by more than 180°C at any point. Loss of “integrity” also constitutes loss of “insulation”.*

*Columns and beams have to satisfy only the criterion of “loadbearing capacity”; glazed elements are normally required to satisfy only “integrity”; and floors and walls have to satisfy all three criteria. It is pertinent to note that under Table 3.4A, doors are only required to satisfy “integrity”, leaving aside “insulation” as it is assumed unlikely that combustible materials would be stored against them. However, doors to protected lobbies, exit staircases and exit passageways should be provided with insulation against transmission of heat by radiation from the fire floor into the protected enclosures which occupants use for evacuation.*

*It is important to note that fire rated glass door shall not be used in fire lift shaft, exit staircases and exit passageways. In other areas such as protected lobbies, separating and compartment walls, the use of fire rated glass is permitted, provided the building is sprinklered protected. Please see clause 3.15.13 for more details.*

### 3.4.2

#### *“Deem to satisfy” provisions*

*An element of structure, door or other part of a building shall be deemed to have the requisite fire resistance if -*

- (a) It is constructed to the same specification as that of a specimen exposed to test by fire in accordance with the method and procedure under BS 476: Part 20 to 23, and satisfied the requirements of that test for the three performance criteria of stability, integrity and insulation for not less than the specified period , or
- (b) In the case of a wall, beam, column, stanchion or floor to which Appendix A to Cl. 3.4 relates, it is constructed in accordance with one of the specification set out in that Appendix and the notional period of fire resistance given in that Appendix as being appropriate to that type of construction and other relevant factors is not less than the specified period.

*(No illustration)*

*Sub-clause 3.4.2(b) provides the alternative to complying with the specification of tested prototype under BS476 Part 20 to 23. Specification set out in Appendix A to Cl.3.4 could be used and there is no need to obtain separate testing. However, on completion of the building works, the qualified person concerned is to forward to the RIs his/her certificate of supervision that the relevant specification listed in Appendix A to Cl. 3.4 had been complied with on site when applying for TFP or FSC.*

### 3.4.3

#### Timber floors

The use of timber floors shall not be allowed, except:

- (a) for an attic in buildings; and
- (b) in buildings designated for conservation where the timber floors are required to be retained, but subject to compliance with the technical guidelines for 'FIRE SAFETY REQUIREMENTS AFFECTING SHOPHOUSES UNDER CONSERVATION.'

*(No illustration)*

*Under clause 1.1.2, the "Fire Safety Requirements Affecting Shophouses Under Conservation" shall also be applicable to old shophouses (build before 1969) not designated for conservation.*

### 3.5 External wall

3.5.1 Requirements of External Walls shall be as follows :

- (a) Any external wall of a building or a separated part of a building which constitutes or is situated within a distance of 1 m from any point on the relevant boundary, or is a wall of a building or a separated part of a building which exceeds 15 m in height shall
  - (i) be constructed wholly of non-combustible materials apart from any external cladding which complies with Cl. 3.5.4 or any internal lining which complies with Cl. 3.13.4, and
  - (ii) be so constructed as to attain the fire resistance required by this chapter, and
- (b) Any beam or column forming part of an external wall and any structure carrying an external wall which is required to be constructed of non-combustible material, shall comply with the provisions of sub-cl. (a).

Buildings of any height situated at 1m or less from relevant boundary

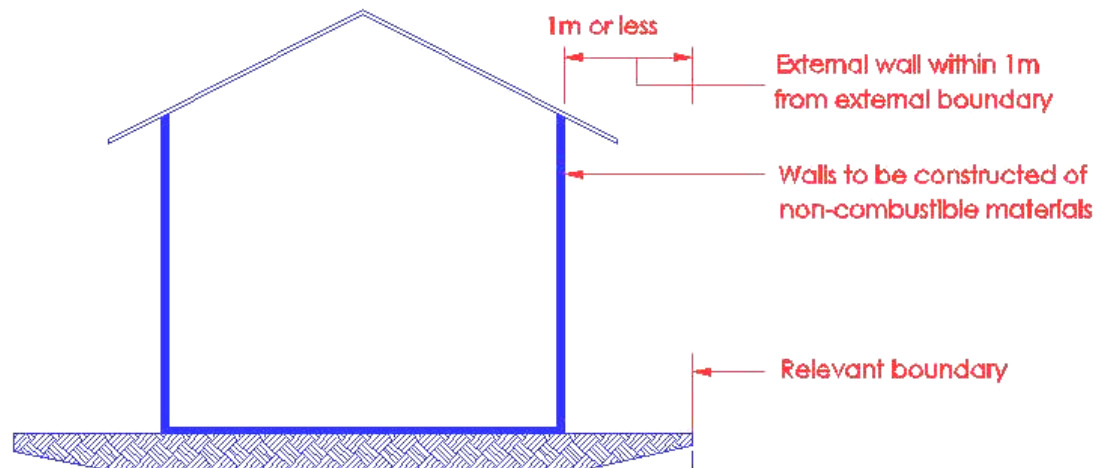

Diagram 3.5.1 - (1)

Buildings of any height situated at 1 m or less from relevant boundary

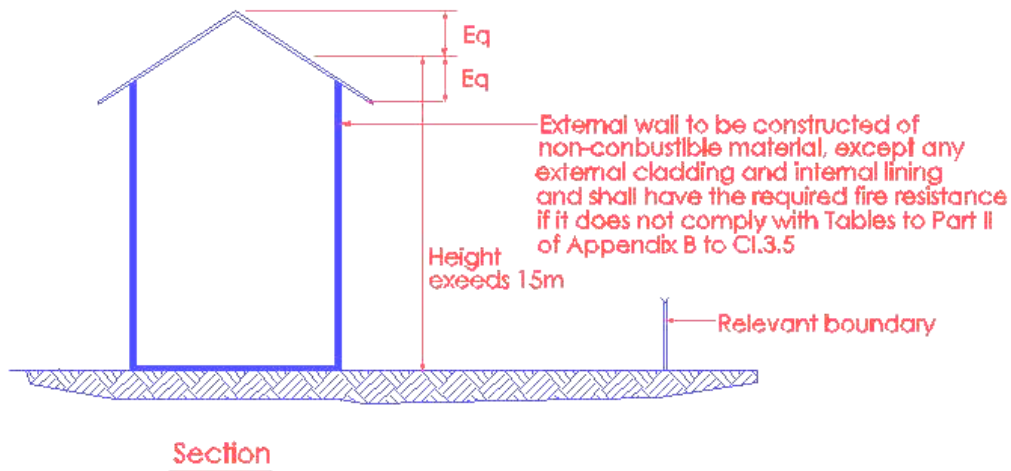

Diagram 3.5.1 – (2)

3.5.2 Exceptions

The requirements of Cl. 3.5.1(a)(i) for non-combustibility of external walls shall not apply to the external wall of a building or separated part of a building-

- (b) if that wall is situated 1 m or more from the relevant boundary:
  - (i) of not more than three storeys.

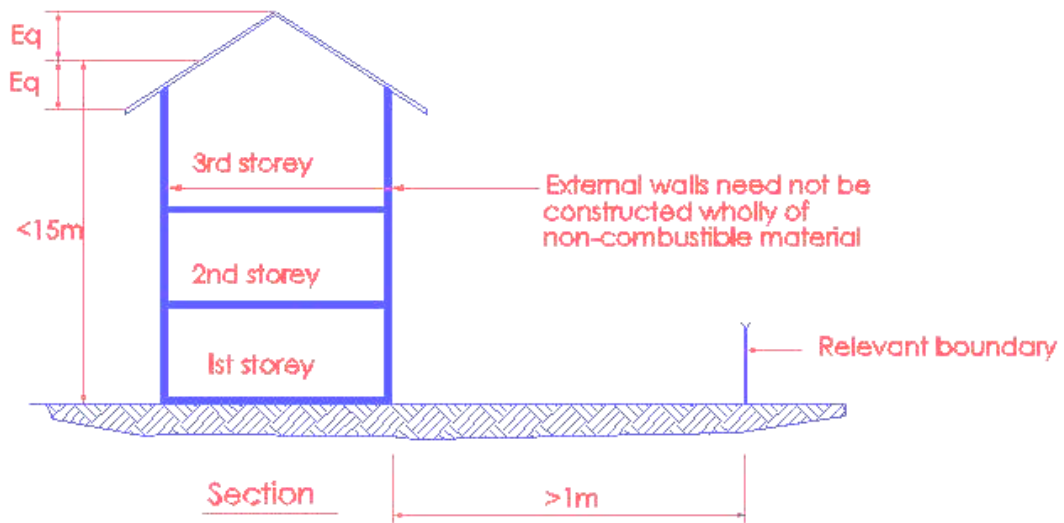

Diagram 3.5.2(b)

- a) External walls to building under purpose group I need not be constructed wholly of non-combustible materials if :
- a. the building does not exceed 3 storey, and
  - b. the external wall is situated 1m or more from the relevant boundary
- b) However, any beam or column forming part of an external wall and any structure carrying an external wall shall be constructed of non-combustible materials and have the necessary fire resistance rating as the elements of structure, apart from any external cladding which complies with Cl.3.5.4 or any internal lining which complies with Cl.3.13.4.

3.5.3 Except where otherwise provided, unprotected areas in any side of a building shall comply with the following:

- (a) Unprotected areas in any side of a building  
Any relevant requirements relating to the permitted limits of unprotected areas specified in Appendix B unless the building is so situated that such side may in accordance with Appendix B consists entirely of any unprotected area, and

Relaxation on Calculations of Unprotected Openings/  
Setback Requirement

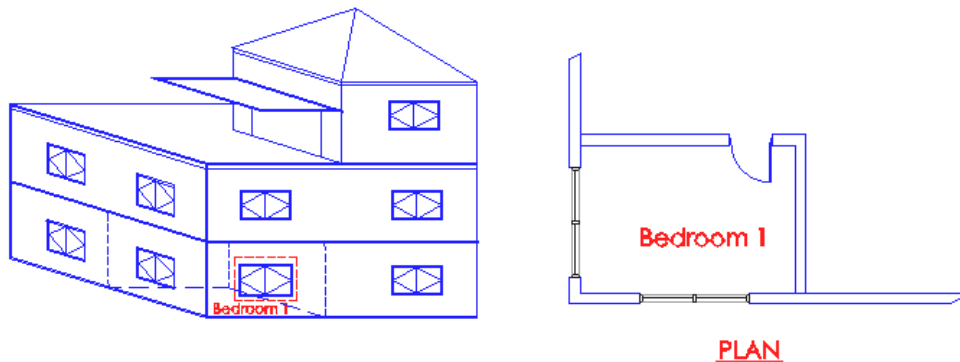

The relaxation of the enclosing rectangular for individual room is only applicable to buildings under purpose group I. This is because every room is enclosed by walls and could be construed as a compartment for the calculations of unprotected openings and setback requirement.

3.5.4 Cladding on External Walls shall comply with the following:

- (a) Cladding on external walls

If such cladding is situated less than 1 m from any point on the relevant boundary, it shall have surface complying with the requirements for Class `0', and

- (b) If such cladding is situated 1 m or more from the relevant boundary it shall have, if the building is more than 15 m in height, a surface complying with the requirements specified for Class '0', except that any part of such cladding below a height of 15 m from the ground may consist of timber of not less than 9 mm finished thickness or of a material having a surface which, when tested in accordance with BS 476: Part 6 have an index of performance (I) not exceeding 20.

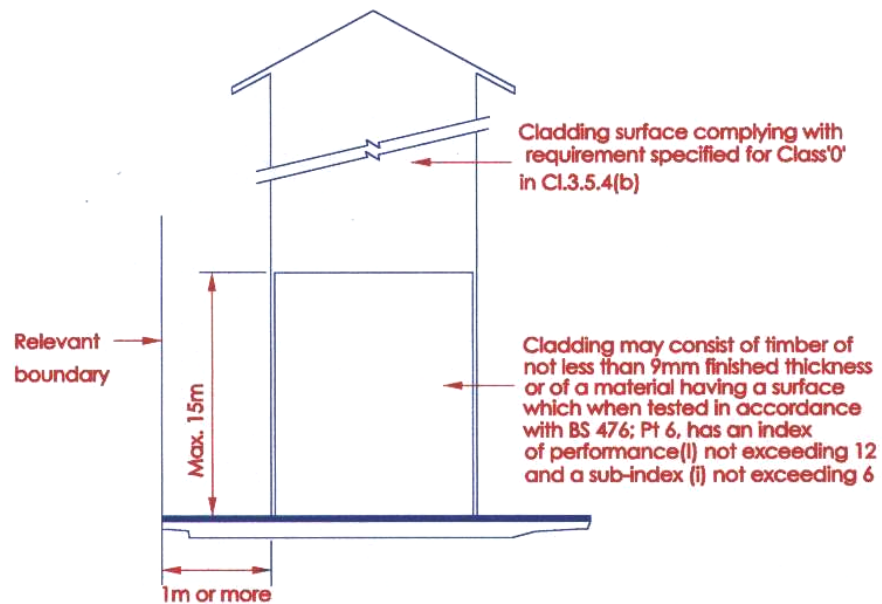

Diagram 3.5.4(a)

- (a) If such cladding is situated less than 1m from the relevant boundary, it shall have surface complying with the requirements for Class '0'.
- (b) If such cladding is situated 1m or more from the relevant boundary and the building is more than 15m,
- (i) any part that is situated above 15m from the ground shall have a surface complying with the requirements for Class '0'.
  - (ii) any part that is situated below a height of 15m from the ground may consist of timber of finished thickness not less than 9mm or of a material having a surface which, when tested in accordance with BS 476 Pt 6 has an index of performance (I) not exceeding 20. The index of performance is derived from the fire propagation test which provides a comparative measure of the contribution a material will make to the heat build-up and thus to fire spread within a room or space.



Values range in descending order of merit from '0' (non-combustible material) to '100'. For example, 18mm thick softwood has an index of performance (I) 42.5 as compared to 13mm thick plaster board which has a value of 9.9.

### 3.5.5 Reference to Part I-II of Appendix B

Any reference to Appendix B shall be construed as referring to the provisions of Part I of that Appendix together with the provisions of Part II.

### 3.5.6 Buildings on land in common occupation

If two or more detached buildings are erected on land in common occupation, any external wall of any building so erected which faces an external wall of such other building, the relevant boundary shall be a notional boundary passing between those buildings and such boundary must be capable of being situated in such a position as to enable the external walls of those buildings to comply with the requirements of Cl. 3.5.3.

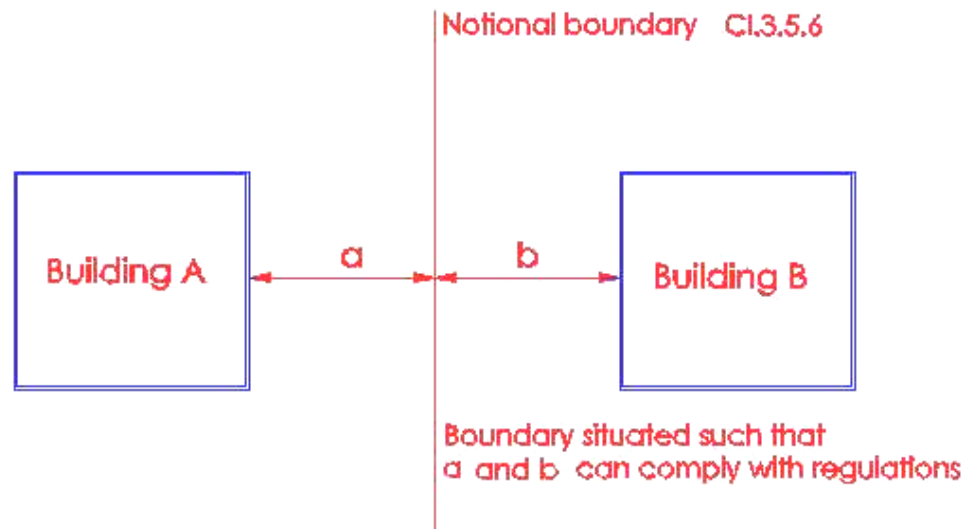

Diagram 3.5.4(a)

- (a) It is necessary to assume a notional boundary when two or more detached buildings are erected on land in common occupation.
- (b) The notional boundary is taken to exist in space between the buildings and is positioned so that the external walls of building A and B facing the notional boundary comply with the separation distance requirement in accordance with Tables of Appendix B, based on the percentage of unprotected area and the purpose group of the compartment/floor.
- (c) Unprotected openings shall be assessed for each building separately. The separation distance between the two buildings shall be not less than the sum of the distance each building would require to a relevant boundary i.e. "a" is equal to or greater than the separation distance to the boundary for building A and "b" is equal to or greater than the separation distance to the relevant boundary for building B.

- (d) *The notional boundary can be shifted next to external wall of building A or B, if the external wall has no unprotected areas and is constructed of non-combustible materials having the requisite period of fire resistance rating as the elements of structure of the storey compartment.*

## **3.6 SEPARATING WALLS**

3.6.1 Every separating wall shall:

- (a) Form a complete barrier in the same continuous vertical plane through the full height between the buildings it separates, including roofs and basements and shall be imperforate except for provisions of openings permitted under Cl.3.6.2, and
- (b) Have the appropriate fire resistance to comply with the requirements of Cl.3.3, and
- (c) Be constructed of non-combustible materials, together with any beam and column which form part of the wall and any structure which it carries.
- (d) Not include glass fire resisting walls
- (e) Exception

Subclause (a) need not be applied to wall between car porches of buildings under purpose group I. For terrace-housing situation, this exception will not apply if the carporch is spanning from one side boundary to the other.

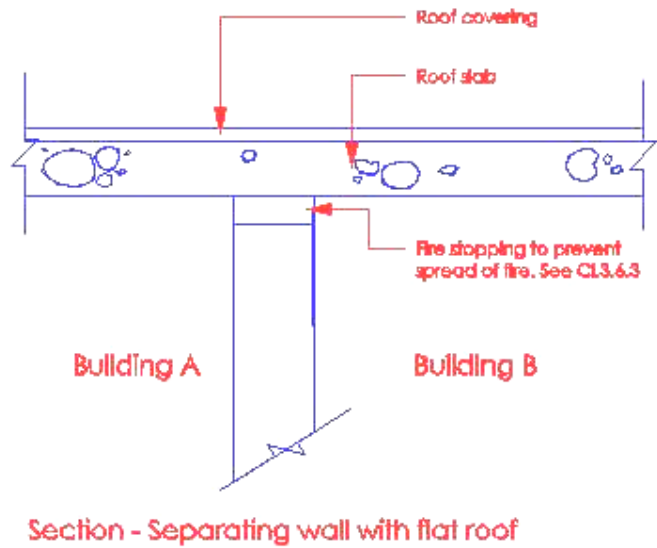

Diagram 3.6.1(a)

Separating wall is the common wall that separates one house from another, as in the case of semi-detached or terraced houses. It is to prevent the spread of fire from house to house. The separating wall shall have the appropriate fire resistance rating as the elements of structure of the adjoining house having the larger floor area or cubical extent as the case may be. It shall not include fire resisting glass.

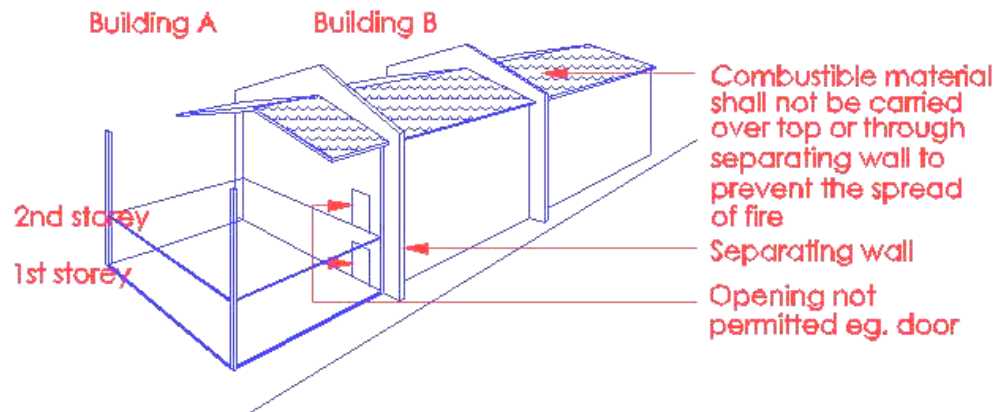

Diagram 3.6.1(b)

Separating wall with pitched roof

Door opening in the separating wall to provide communication between 2 houses is not acceptable, unless the 2 houses are under single ownership and occupied by single family. Owner is required to furnish an undertaking to FSSD that should one of the houses is to be sold, the door opening in the separating wall shall be bricked-up to have the necessary fire resistance as the adjoining wall.

**Acceptable**

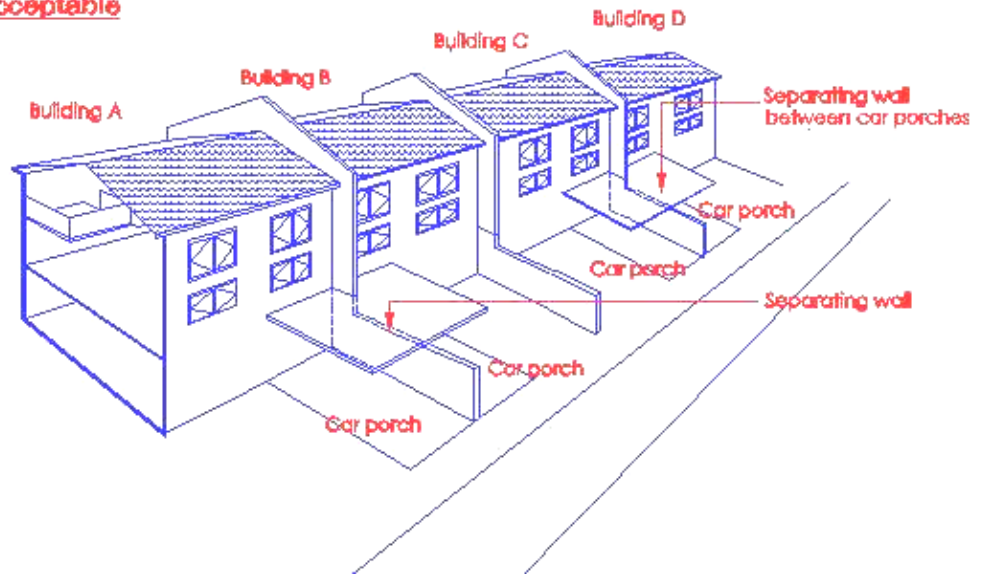

Diagram 3.6.1(c)-1

**Not acceptable**

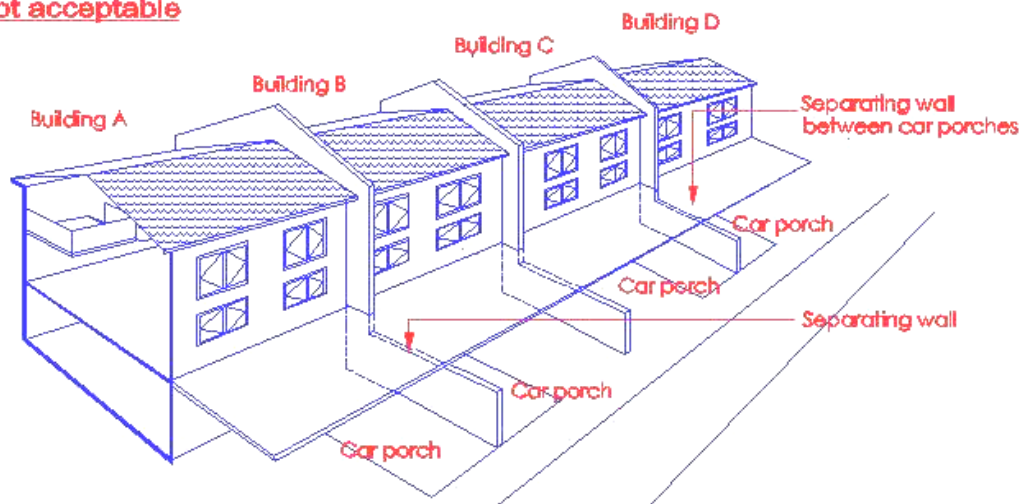

Diagram 3.6.1(c) - 2

The wall that separates the car porch of one house from the other is considered as a separating wall; hence it shall form a complete barrier in the same continuous vertical plane through the full height between the houses. The wall shall be imperforate and provided with proper fire stopping at the roof junction of the car porch.

If the roof to the car porches is not spanning from one side boundary to the other as shown in diagram 3.6.1(c)-1, then the separating wall between the 2 car porches need not be full height.

If the roof of the car porch is spanning from one side boundary to the other, then the separating wall between the car porches is required to be constructed of full height, brought right - up to the underside of the roof slab or covering.

### 3.6.2 Openings in separating

A separating wall shall have no openings except for -

- (a) A door required to provide a means of escape in the event of a fire, having the same fire resistance as that required for the wall and complying with Cl. 3.9.2, or

*(No illustration, see diagram 3.6.1(b))*

Opening in the separating wall shall comply with the following conditions :

- i) QP shall obtain prior approval from FSSD before submission of building plan.
- ii) If the adjoining unit or building is under different ownership; written consent from the owner shall be obtained for submission to FSSD.
- iii) Owner is to submit a written undertaking to FSSD that should the opening in the separating wall is no longer required, it shall be restored to its original imperforate state.

*(No illustration)*

### 3.6.3 Separating wall – roof junction

A separating wall shall be either carried up to form a close joint with the underside of a pitched roof of non-combustible covering or carried up above the level of such roof covering. The junction between such separating wall and roof shall be properly fire stopped so as not to render ineffective the resistance of such separating wall to the effects of the spread of fire.

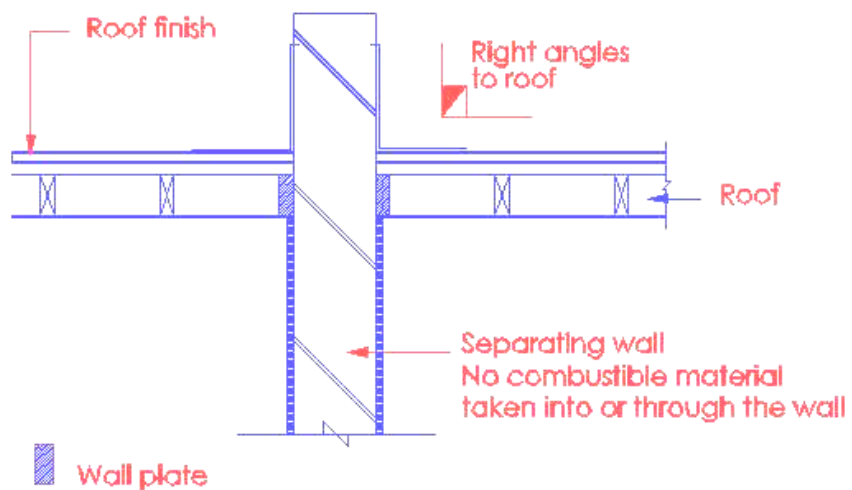

Diagram 3.6.3

Separating wall is carried up above the roof coverings to act as a barrier to prevent fire spread over the roof level

### 3.6.5

#### Prohibition of combustible materials in separating walls

No combustible material shall be built into, carried through or carried across the ends of or carried over the top of separating walls in such a way as to render ineffective such separating walls to the effects of the spread of fire.

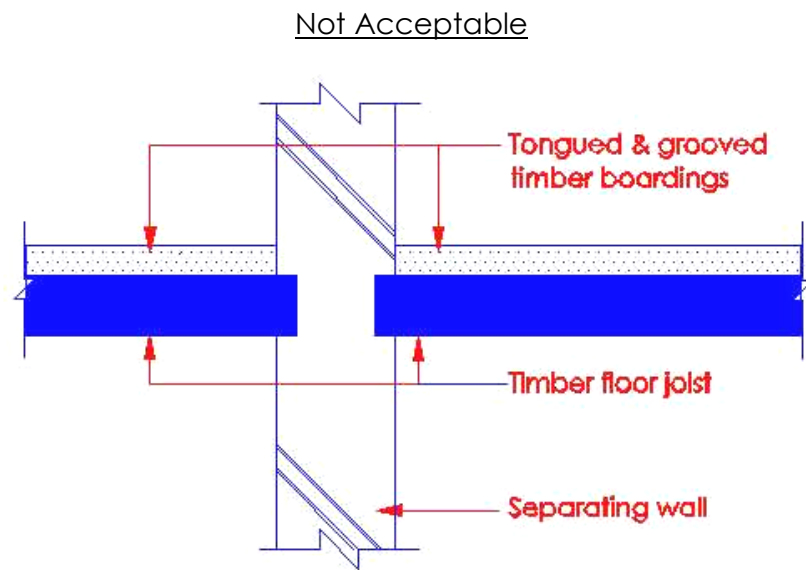

Diagram 3.6.5 - (a)

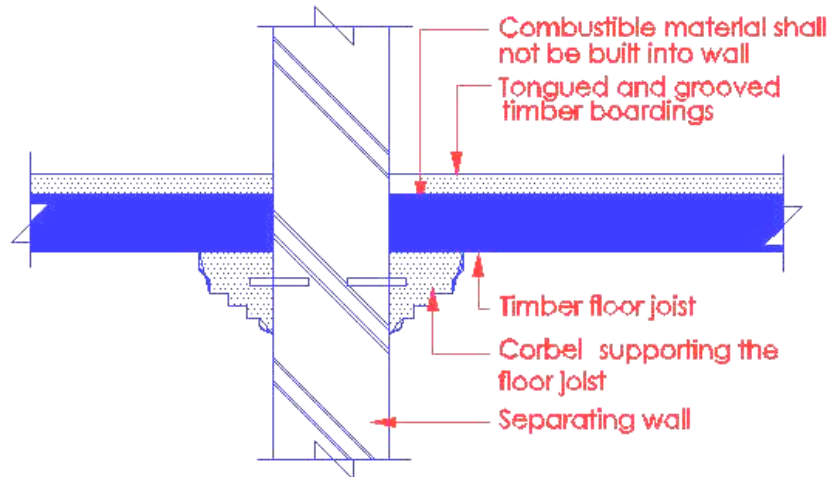

Diagram 3.6.5 - (b)

Combustible materials built into separating wall would weaken the fire resistance integrity of the wall. However, for building under conservation, it would be acceptable if the original method of construction of floor is required to be retained.

### 3.7 COMPARTMENT WALLS AND COMPARTMENT FLOORS

#### 3.7.1 Requirements of compartment walls or compartment floors.

Every compartment wall or compartment floor shall be required to -

- (a) Form a complete barrier to fire between the compartments it separates, and
- (b) Have the appropriate fire resistance to comply with the requirements of Cl.3.3, and
- (c) Be constructed of non-combustible materials (together with any beam or column which forms part of the wall or floor and any structure which it carries), and
- (d) Have no fire resisting glass forming part of it unless permitted by the Relevant Authority.

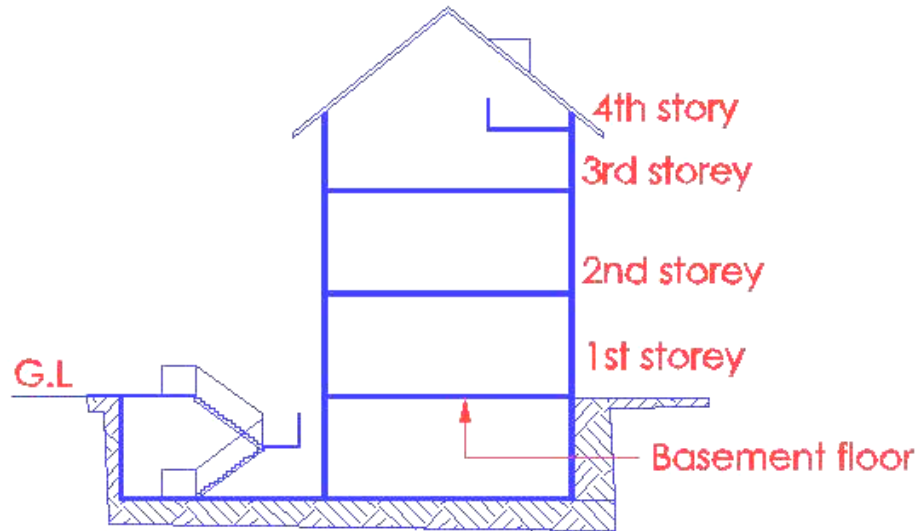

Section – Compartment floor over basement

Diagram 3.7.1 – (a)

The provision of compartment floor would apply to separate basement from upper storeys in the case where the building has 4 or more upper storeys or levels and a basement. Under such situation, Cl.3.2.4(d) shall be complied with i.e. the compartmentation between basement and 1<sup>st</sup> storey shall not be penetrated by any openings or services even if :

- (i) such openings are provided with fire doors; and
- (ii) the services are in protected shafts.

### 3.7.2 Openings in compartment

A compartment wall or compartment floor shall have no openings in it, except for -

- (a) A door which has the same fire resistance rating as the compartment wall and complies with the relevant requirements of Cl. 3.4, unless permitted by other provisions of the Code, or
- (b) A protected shaft which complies with the requirements of Cl. 3.8, or
- (c) The passage of a pipe or ventilation duct,

such openings in the compartment wall or compartment floor shall be protected to comply with the relevant provisions of Cl. 3.9.



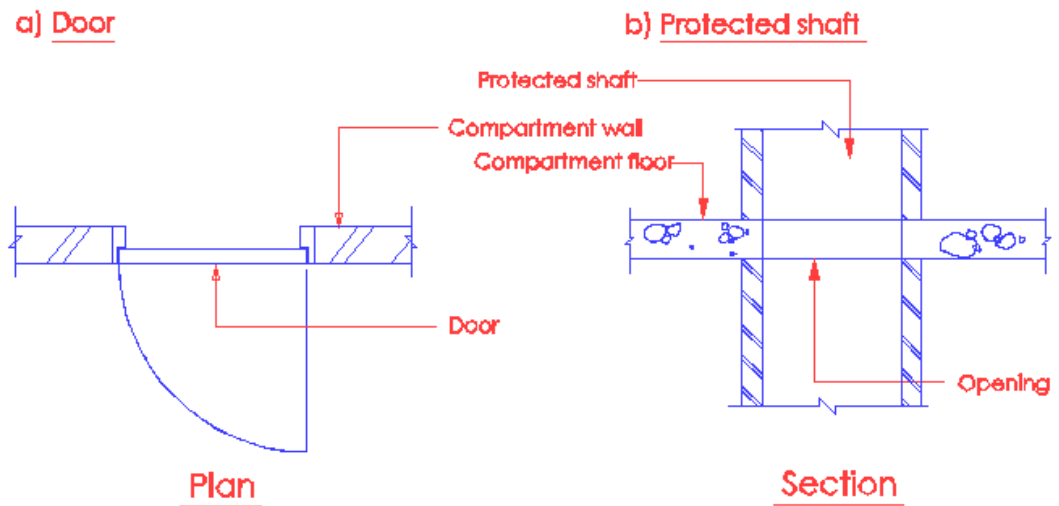

Diagram 3.7.2

3.7.3

(a) Junction with other structures

Where a compartment wall or compartment floor forms a junction with any structure comprising any other compartment wall, or any external wall, separating wall or structure enclosing a protected shaft, such structures shall be bonded together at the junctions or the junctions shall be fire-stopped to comply with the requirements of Cl. 3.12.

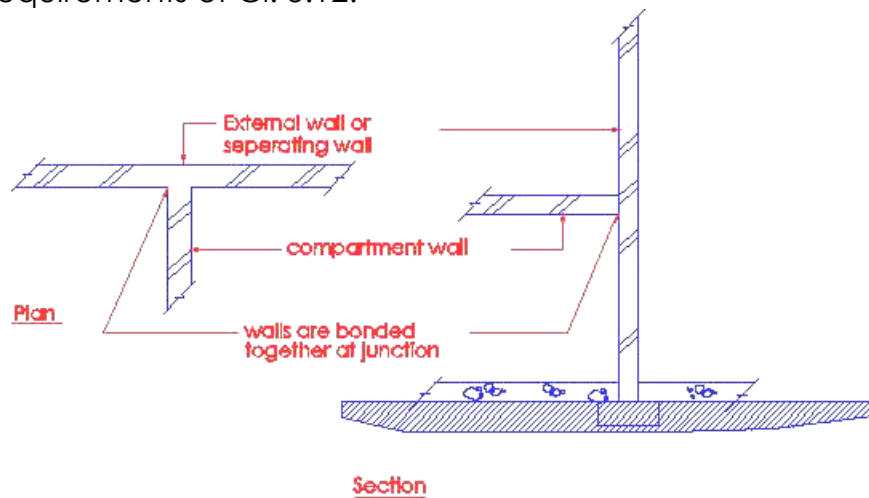

Diagram 3.7.3(a)

(b) Opening in curtain walling

The opening occurring at the junction between the edge of a structural floor and the curtain walling shall be sealed to prevent the spread of smoke and flame from the lower floor to the upper floor via the opening. Materials to be used for sealing the opening shall have the requisite fire resistance rating as the

elements of structure.

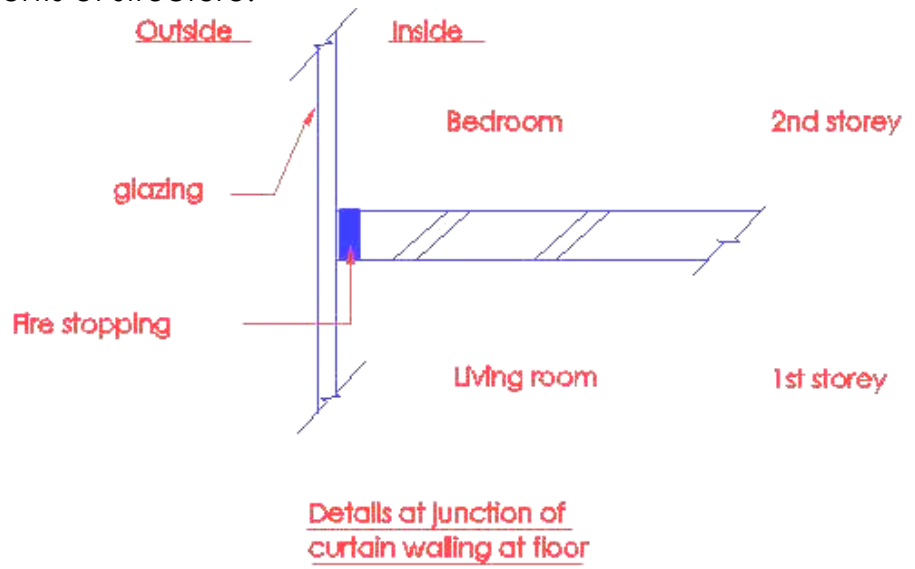

Diagram 3.7.3(b)

### 3.7.4

#### Compartment wall - roof junctions

Where a compartment wall forms a junction with a roof, such compartment wall shall be carried up to form a close joint with the underside of the roof and shall be properly fire-stopped or shall be carried up above the level of the roof covering and the junction between such compartment wall and roof shall be properly fire-stopped so as not to render ineffective the resistance of such compartment wall to the effects of the spread of fire.

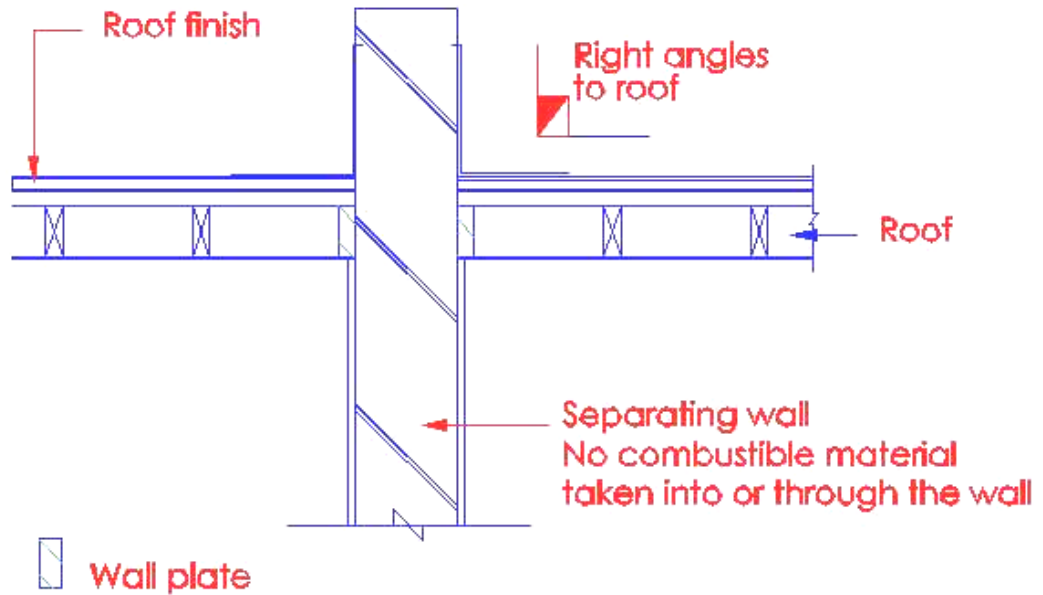

Diagram 3.7.4

Compartment wall is carried right up above the roof coverings to act as a barrier to prevent fire spread over the roof level. The above clause addresses the concern at the junction of compartment walls with roofs and other elements of structure to prevent fire spreading through cracks and gaps at such junctions

### 3.7.5 Prohibition of combustible materials

No combustible material shall be built into, carried through or carried across the ends of any compartment wall or compartment floor or carried over the top of any compartment wall in such a manner as to render ineffective the resistance of such wall or floor to the effects of the spread of fire.

See subclause 3.6.5 (Prohibition of combustible material in separating wall)

### 3.7.6 Non-combustibility of compartment walls or floors

Every compartment wall or compartment floor shall be constructed of non-combustible materials, unless permitted by the Relevant Authority.

(No illustration)

Construction of compartment walls and floors shall be constructed entirely of non-combustible material. However, there were exceptions specially allowed for under the conservation programme. The exemption was an understanding between FSSB and URA. As a general guide, Qps are required to seek prior consultation with FSSB before making BP submission.

Any structural members carrying compartment walls or floors must also comply with the requirement of non-combustibility. Apart from the contribution made by suspended ceilings under CL.3.3.6, the fire resistance of the structural members must be attained without assistance from any combustible material (with the exception of buildings designated for conservation).

### 3.9.3

#### Pipes

Pipes which pass through a separating wall, compartment wall or compartment floor shall be kept as small as possible and fire-stopped around the pipe. The nominal internal diameter of the pipe shall be not more than the relevant dimension given in Table 3.9A. Spacing between pipes shall be minimum 50mm or  $\frac{1}{2}$ -diameter of the largest pipe, whichever is larger.

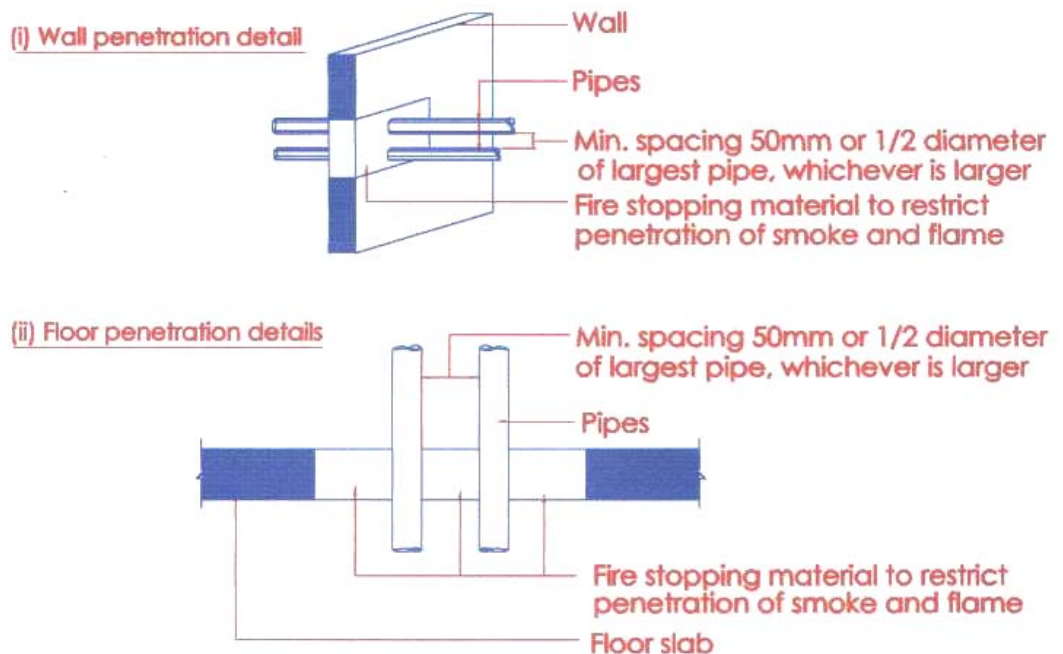

Diagram 3.9.3-1

The clustering of pipes without proper spacing would further weaken the integrity of the fire resisting walls in times of fire emergency.

3.11.12 Buildings under purpose group I are not required to comply with the requirements on the provision of cavity barrier in concealed spaces.  
(No illustration)

### 3.12 FIRE STOPPING

#### General Provision

Openings for pipes, ducts, conduits or cables which pass through any part of an Element of Structure (except for a part which does not serve as a fire resisting barrier) or Cavity Barrier, shall be :

- (a) Kept as few in number as possible, and
- (b) Kept as small as practicable, and
- (c) All gaps shall be filled with fire-stopping materials.

#### Fire stopping to a pipe in a compartment wall

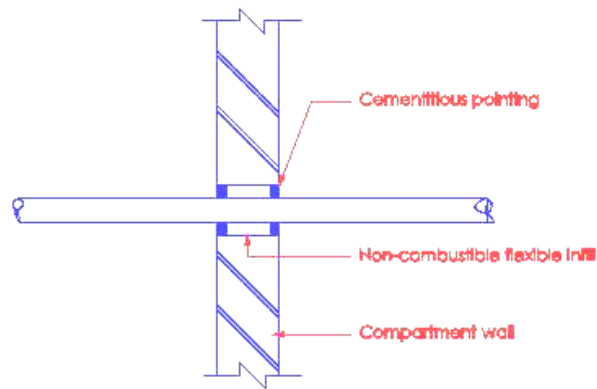

Diagram 3.12.1

Fire stopping is concerned with ensuring that the fire-resisting capability of a component ,i.e separating wall, compartment wall/floor, cavity barrier is not diminished or impaired when penetrated by services for example, a pipe, ducts etc. Therefore whenever gaps are created by the penetration of such pipes, ducts in the fire rated wall/floor, they must be kept as few as possible. The spacing and internal diameter of pipes passing through any elements of structure or cavity barrier shall comply with Cl.3.9.3 and Table 3.9A.

#### 3.12.2 Fire stopping

Fire-stopping shall be of material having the necessary fire resistance when tested to BS 476: Part 20 or other acceptable standards.  
( No illustration )

#### 3.12.3 Materials for fire- stopping

Suitable fire Stopping materials include:

- (a) Proprietary fire stopping and sealing systems (including those designed for service penetrations) which have been shown by test to maintain the fire resistance of the wall or other element, subject to approval by the Relevant Authority.
- (b) Other fire-stopping materials include:
  - (i) cement mortar;
  - (ii) gypsum based plaster;
  - (iii) cement or gypsum based vermiculite/perlite mixes;
  - (iv) glass fibre, crushed rock, blast furnace slag or ceramic based products (with or without resin binders), and
  - (v) intumescent mastics.

The method of fire stopping and choice of materials should be appropriate to the situation and its application.

*(No illustration)*

*To prevent displacement, materials used for fire-stopping should be reinforced with (or supported by) materials of limited combustibility in the following circumstances:*

- (i) in all cases where the unsupported span is greater than 100mm, and*
- (ii) in any other cases where non-rigid materials are used (unless they have been shown to be satisfactory by test)*

*Preference should be given to proprietary fire-stopping and sealing system.*

*When cement mortar or gypsum board plaster or cement or gypsum based vermiculite/perlite mixes is used as fire stopping material, care should be exercised to ensure that workmen properly fill up the entire gaps with the appropriate fire stopping material instead of carrying cosmetic application by just filling up the gaps superficially.*

### **3.13**

#### **RESTRICTION OF SPREAD OF FLAME OVER SURFACES OF WALLS AND CEILINGS**

- a. *Polymeric materials eg plastic and foam (polystyrene, polyurethane) should not be used for wall/ceiling finishes.*
- b. *Wall and ceiling finishes in the form of thin sheet of not more than 0.8mm thickness mounted on non-combustible substrate are allowed to be used. These finishes would not be required to meet the requirements of spread of flame provision, provided that this exception shall not apply to smoke-stop lobbies, exit staircases and exit passageways.*
- c. *Walls and ceiling finishes shall comply with the following:*

	Rooms or compartments	Circulation spaces Excluding smoke-stop lobbies, exit staircases & exit passageways
	Wall : No control	Class 0
	Ceiling : No control	Class 0

The above table spells out the requirements of spread of flame to surfaces of walls and ceilings in the building.

### 3.13.1 Requirements for Class 0

Any reference to a surface being Class 0 shall be construed as a requirement that -

- (a) The material of which the wall or ceiling is constructed shall be non-combustible throughout; or
- (b) The surface material (or, if it is bonded throughout to a substrate, the surface material in conjunction with the substrate) shall have a surface of Class 1 and if tested in accordance with BS 476: Part 6 shall have an index of performance (I) not exceeding 12 and a sub-index (i) not exceeding 6.

*(No illustration)*

*BS 476:Part 6 refers to a standard fire test for propagation of products.*

*Under this test, there is a means of comparing the contribution of combustible building materials to the growth of a fire by providing a measure of the rate of heat evolution of the samples, exposed in a small combustion chamber.*

*The performance of each sample is expressed as a numerical index from 0 to 100 or more. Low values of the indexes indicate a low rate of heat release. Three to five specimens are tested.*

*Index of performance  $I = I_1 + I_2 + I_3$  where sub-index  $i_1$  is derived from the first three minutes of test,  $i_2$  from the following seven minutes, and  $i_3$  from the final ten minutes. A high index  $i_1$  indicates an initial rapid ignition and heat release.*

### 3.13.2 Requirements for a class other than class 0 classification

Any reference to a surface being of a class other than Class 0 shall be construed as a requirement that the material which the wall or ceiling is constructed shall comply with the relevant test criteria as to surface spread of flame specified in relation to that class in BS 476: Part 7.

*(No illustration)*

*Test under BS 476: Part 7 refers to a standard fire test for the classification of the surface spread of flame of products.*

*This test is able to determine the tendency of surfaces of flat materials to support the spread of flame across their surfaces and specifies a method of classification appropriate to wall and ceiling linings. Class 1 represents the best performance, followed in descending order by Class 2, Class 3 and Class 4.*

### 3.13.3

Class 0 shall be regarded as the highest class followed in descending order by Class 1, Class 2, Class 3 and Class 4, as set hereunder:

- \* Class 0 - Surface of no Flame Spread. Those surfaces that conform to the requirements of Cl. 3.13.1.
- \* Class 1 - Surface of Very Low Flame Spread. Those surfaces on which not more than 150mm mean spread of flames occurs under the relevant test conditions.  
  
Class 2 - Surface of Low Flame Spread. Those surfaces on which during the first 1-1/2 minutes of test, the mean spread of flame is not more than 375 mm and the final spread does not exceed 450 mm under the relevant test conditions.
- \* Class 3 - Surface of Medium Flame Spread. Those surfaces on which during the first 1-1/2 minutes of test, the mean spread of flame is not more than 375 mm and during the first 10 minutes of test is not more than 825 mm under the relevant test conditions.
- \* Class 4 - Surface of Rapid Flame Spread. Those surfaces on which during the first 1-1/2 minutes of test the mean spread of flame is more than 375 mm and during the first 10 minutes of test is more than 825 mm under the relevant conditions.

*(No illustration)*

*The reason for having Class 0 is that Class 1 covered too wide a range of performance for use in critical areas. Where a higher degree of protection is required, for example in smoke stop lobbies, exit staircases, exit passageways (which constitute the escape route), Class 0 is specified.*

### 3.13.5

- (a) Where class of flame spread may be of any class not lower than class 3  
Any part of the surface of a wall in a room or compartment may be of any class not lower than Class 3 if the area of that part ( or if there are two or more such parts, the total area of those parts) does not exceed the following -



- (i) in the case of a building or compartment of purpose group I, 20m<sup>2</sup>

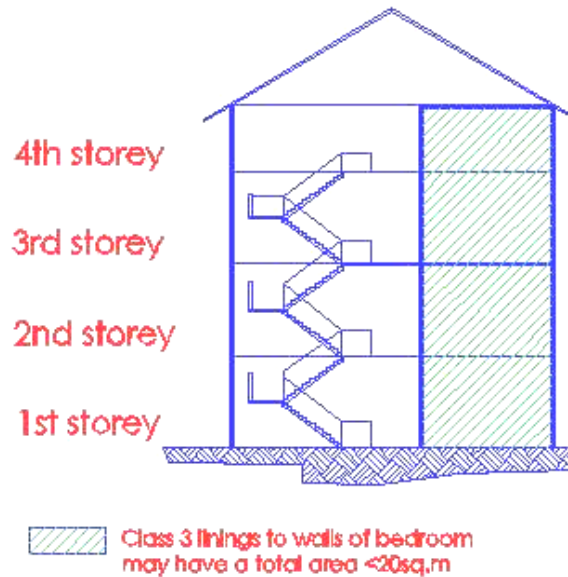

Diagram 3.13.5a

The linings to internal surfaces of a wall in a room or compartment are permitted to have any Class as permitted under Table 3.13A

- (b) Any part of the surface of a ceiling may be of any class not lower than Class 3 if that part of the surface is the face of a layer of material the other face of which is exposed to the external air (skylight included) and -
- (iii) the ceiling is that of a balcony, verandah, open carport, covered way or loading bay which (irrespective of its floor area) has at least one of its longer sides wholly and permanently open, or

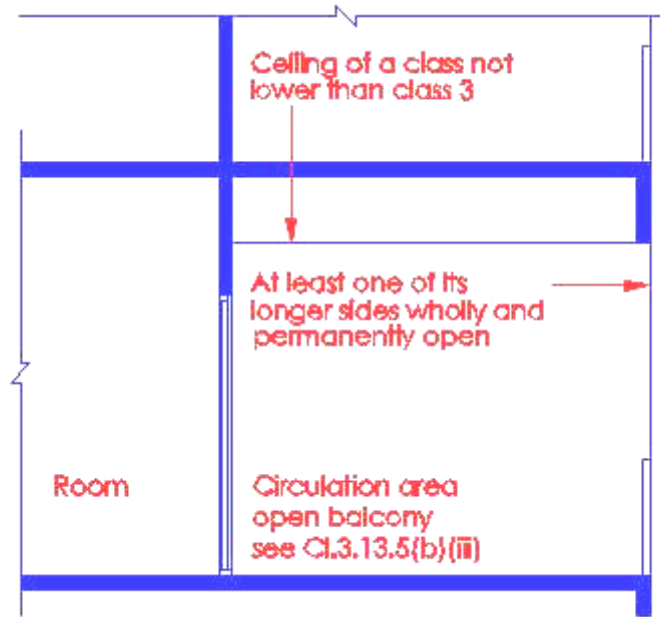

Diagram 3.13.5b-2

- (iv) the ceiling is that of a garage or outbuilding which (irrespective of whether it forms part of a building or is a building which is attached to another building or wholly detached ) has floor area not exceeding 40 m<sup>2</sup>.

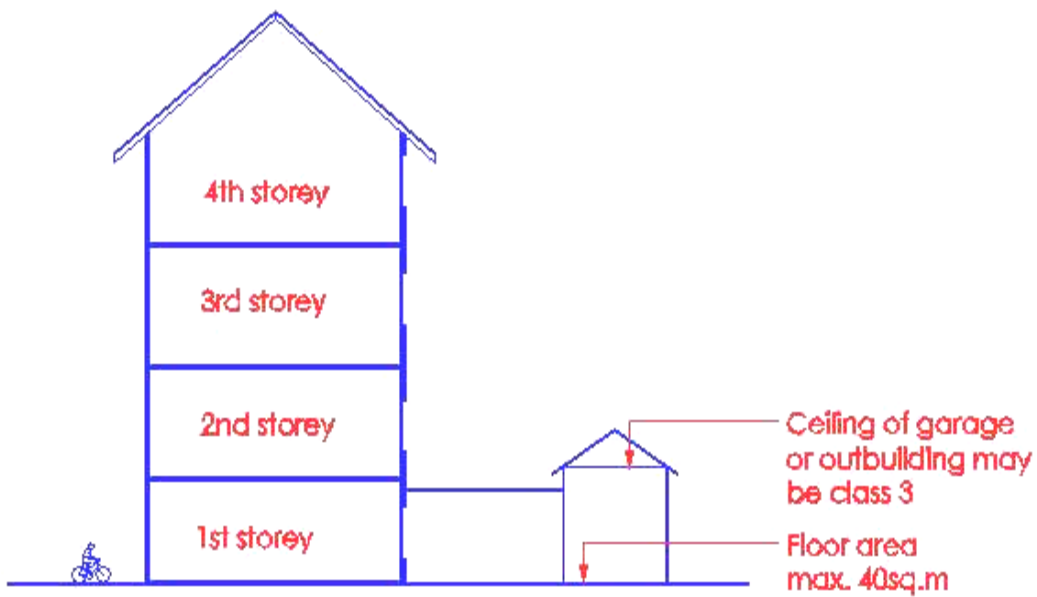

Diagram 3.13.5b-4

Finishes to ceilings in circulation space in the building shall have a surface flame spread rating of not lower than Class 0 as required for under Table 3.13A

Finishes to ceiling of a room or compartment are permitted to have any class as permitted under Table 3.13A.

### 3.14.1 Roof construction

Surface of materials for roof covering and roof construction shall have a surface spread of flame rating not lower than class 1, except in the case of purpose groups I, and in buildings that are protected throughout with automatic sprinkler system in compliance with Chapter 6.

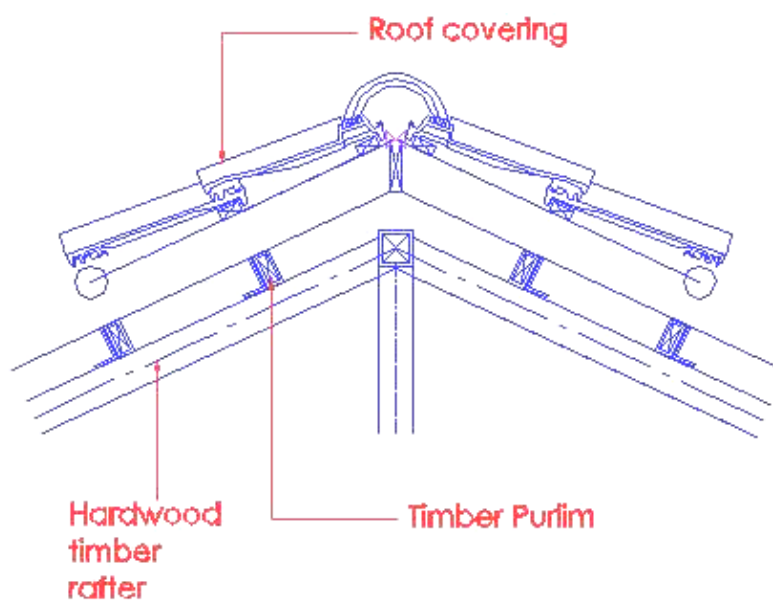

Diagram 3.14.1

Roof construction to buildings under Purpose Group I usually use timber rafters and purlins for tiled roofs. Rooflights of combustible materials are usually used for lighting purposes. Generally, buildings under Purpose group I are small in area and low-rise. For semi-detached and terraced houses, the separating walls would be brought right-up to the underside of or above the roof coverings to prevent spread of fire.

### 3.14.3 Roof junction with separating wall and compartment wall

At the junctions with separating wall or compartment wall, roof construction shall comply with the relevant requirements under Cl. 3.6.3 and Cl. 3.7.4 respectively.

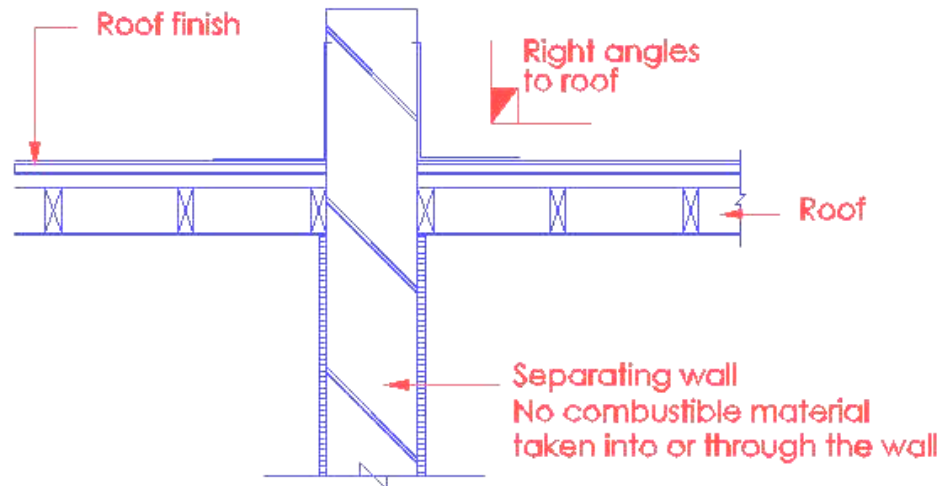

Diagram 3.14.3

3.14.4

Roof terrace

Roof terrace shall not be roofed over. If it is either partially or fully roofed over, it shall be considered as a habitable floor.

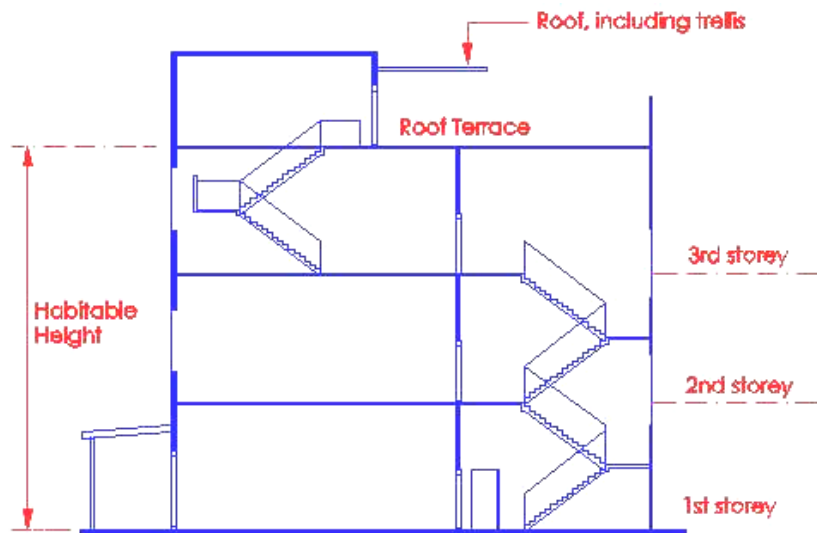

Diagram 3.14.4

## Roof Terrace

### a) Means of escape

Roof terrace even if not roofed over could be used by building owners to hold private functions. In this respect, the roof terrace would attract additional occupant load, which could be sizeable, depending on the type of function proposed, for example, a private dinner function could be held on the open roof terrace. The guests and the hosts that are attending the private function on the roof terrace would be subject to the risk of a fire that could break out in any of the floor space below the roof terrace. For this reason, roof terrace, whether roof over or not should be subjected to compliance with exit capacity and travel distance requirements under the fire code. Roof terrace which exceeds the floor area of 60sq. m shall be provided with a separate exit at terrace level.

### b) Habitable height

For the purpose of determining the habitable height of a building, roof terrace that is either partially or fully roofed over shall be considered as a habitable floor. Thus, if the roof terrace is the highest habitable floor, the habitable height of a building shall be measured from the lowest level of the fire engine access road to the finished floor level of the highest habitable floor.

In the above diagram, the habitable height of the building shall be measured up to the finished floor level of the terrace. Otherwise it shall be measured up to the finished floor level of the 3<sup>rd</sup> storey.

## 3.15.1

- (a) Materials used in the construction of building elements shall comply with the provisions stated under this section in addition to the performance requirements such as for fire resistance and limit to spread of flame as stipulated in other relevant sections of the code.

(No illustration)

### (b) Intumescent Paints

- (i) the paint shall be of a proprietary system that
- (ii) has been demonstrated to achieve the fire resistance performance as required in BS 476 Part 20/21 or its equivalent, together with the specified weathering tests as specified in the BS 8282: Part 2 – 1992;
- (ii) they shall be used to protect structural beams only, excluding load transfer beams, if the habitable height of the building exceeds 24m.
- (iii) coating of intumescent paint onto structural steel, and subsequent maintenance shall conform to BS 8202: Part 2: 1992; and

- (iv) all requirements stipulated in the Appendix to this clause: "Notes on the use of Intumescent Paints for Protection to Structural Steel Members of Buildings" shall be complied with. (Please see Appendix (F))

*(No illustration)*

- (c) Flame retardant chemicals are permitted to be used for upgrading of fire resistance rating or surface spread of flame of timber or any combustible materials, subject to the following:
  - (i) The chemical treatment process is part and parcel of the manufacturing process to produce the finished product ;
  - (ii) The chemical treatment is by means of pressure impregnation conforming to SS CP: 1 – Use of Timber in Building Construction , or the manufacturer's specification in accordance to the prototype test, for timber and other combustible materials respectively.
  - (iii) The treated materials/products have been subjected to fire test as required under Cl 3.4.1 or Cl 3.13.1

*(No illustration)*

3.15.2 All elements of structure shall be constructed of non-combustible materials in addition to the relevant provisions as follows:  
Cl.3.3 for fire resistance of elements of structure,  
Cl.3.5.1, 3.5.2 & 3.5.4 for External Walls,  
Cl.3.6.1(c)/(d) & 3.6.5 for Separating Walls,  
Cl.3.7.1(c)/(d), 3.7.5 & 3.7.6 for Compartment Walls and Compartment Floors,  
Cl.3.8.2(c), 3.8.4, 3.8.7(c), 3.8.8(b), 3.8.8(e) and 3.8.9(a) for Protected Shafts.

*(No illustration)*

3.15.3 Materials used for the protection of openings shall comply with the relevant provisions of cl.3.9 of the code for protection of openings.

*(No illustration)*

3.15.6 Materials used for construction of ceiling and its supports shall comply with Table 3.13B.

*(No illustration)*

- 3.15.8 Materials used for fire stopping shall comply with the relevant provisions of cl.3.12.2 and 3.12.3.  
*(No illustration)*
- 3.15.9 Materials used on the surfaces of walls and ceilings are required to meet the requirements for restriction of spread of flame and to comply with the performance requirements as stipulated under cl.3.13.  
*(No illustration)*
- 3.15.10 Materials used for roof construction shall comply with the provisions of cl.3.14.1 & 3.14.2.  
*(No illustration)*
- 3.15.11 Internal non-load bearing walls in buildings shall comply with Table 3.13B and the materials for surface finishes of internal non-load bearing walls shall not be treated as part of the wall and shall comply with the relevant provisions of cl 3.13.
- 3.15.12 (a) Composite panels which consist of plastic core shall not be used either for the construction of internal non-load bearing walls, ceilings, external walls or as cladding to external walls of all buildings unless prior approval has been obtained from the Relevant Authority.  
(b) Materials with surface flame spread rating of not lower than Class 2 shall be permitted to be used for the construction of partition for toilet cubicles only.  
*(No illustration)*
- 3.15.14 Internal non-load bearing walls, ceilings and finishes shall not contain any plastic material.  
*(No illustration)*